

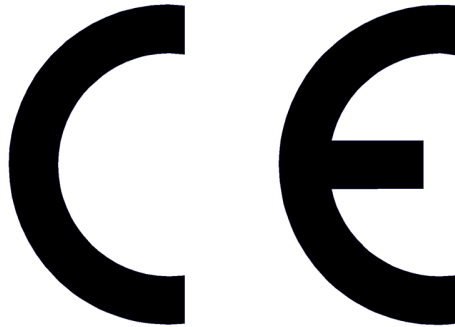

DECLARATION OF CONFORMITY



The manufacturer

Neatech.it

Via A. de Curtis 4/A, 80040, Cercola (NA), Italy

declares that

**the wheelchair EVO 3
(reference code: S042)**

other names: EVO 3 – EVO3 FWD – EVO3 RWD – EVO 3 FWD – EVO 3 RWD

satisfies the requirements laid down by the European Directive 93/42;
according to the criteria for classification of Annex IX of this Directive, it is classified as:

class I medical device;

It also complies with the requirement of the harmonized standards:

EN ISO 14971:2012

UNI EN 12182:2012

UNI EN 12184:2009

Index

1	PRODUCT INFORMATION	1
2	PREPARATION FOR FIRST USE	2
2.1	Checks to be made on delivery	2
2.2	Unpacking	2
2.1	Software description	3
2.1.1	Rnet system: OBP onboard programming.....	4
2.1.2	Rnet system: PC programming.....	5
3	ADJUSTMENTS	11
3.1	Seating system description.....	11
3.2	Powered functions.....	13
3.2.1	AXIS 1: Backrest	15
3.2.2	AXIS 2: Legrest	16
3.2.3	AXIS 3: Tilt.....	18
3.2.4	AXIS 4: Lift.....	20
3.2.5	AXIS 5: Rehab.....	23
3.2.6	AXIS 6: Active negative tilt.....	25
3.2.7	AXIS 7: Semistanding	27
3.2.1	AXIS 8: Laydown	29
3.3	Speed limitations	30
3.4	List of adjustments	32
3.4.1	Version of the wheelchair with biomechanics movements.....	32
3.4.2	Version of the wheelchair without biomechanics movements	33
3.5	Seat depth - Version with biomechanical movements	34
3.6	Armrests depth - Version with biomechanical movements.....	36
3.7	Armrests height - Version with biomechanical movements	38
3.8	Vertical armrests angle - Version with biomechanical movements	40
3.9	Horizontal armrests angle - Version with biomechanical movements	42
3.10	Footplates height - Version with biomechanical movements	43
3.11	Backrest height - Version with biomechanical movements	45
3.12	Joystick position - Version with biomechanical movements.....	47

3.12.1	Standard support - Depth.....	47
3.12.2	Retractable support S045-V263 - Depth	48
3.13	Seat depth- Version without biomechanical movements	49
3.14	Backrest angle- Version without biomechanical movements	51
3.14.1	Adjunctive backrest angle adjustment.....	53
3.15	Armrests depth- Version without biomechanical movements	55
3.16	Armrests height- Version without biomechanical movements.....	58
3.17	Sidepad height- Version without biomechanical movements.....	60
3.18	Footplates height- Version without biomechanical movements	62
3.19	Footplates depth and angle- Version without biomechanical movements	64
3.20	Joystick position- Version without biomechanical movements	66
3.20.1	Standard support - Depth and height.....	66
3.20.1	Retractable support - Depth and height.....	67
3.21	Default position.....	68
4	USE OF THE PRODUCT	69
4.1	Rnet 80 A control system	75
4.2	Manual brake release lever	77
4.3	Use as seat in a motor vehicle	79
4.3.1	Securing the wheelchair with Four points tie-down system.....	86
4.3.2	Dahl engineering docking station.....	88
4.3.3	Mounting of the Dahl engineering docking station - Installation of Dahl Lock plate assembly under the wheelchair	90
4.4	Powered functions.....	95
4.5	Main switch	102
4.6	Battery charging	104
4.7	Transport and storage	106
4.7.1	Batteries removal	106
5	MAINTENANCE	110
5.1	Maintenance and cleaning	110
5.2	Controls to be performed on the product.....	111
5.3	Tire puncture	112
5.3.1	User information	112

5.3.2	Service information	114
5.4	Wiring diagram	116
5.5	Batteries replacement	126
5.6	Reuse	132
5.7	Spare parts.....	133
5.7.1	Fork with dump	135
5.7.2	Antitip wheels.....	139
5.7.3	Cover A.....	141
5.7.4	Cover B.....	143
5.7.5	Motors	145
5.7.6	Main switch	147
5.7.7	Standard joystick support.....	150
5.7.8	Retractable joystick support.....	152
5.7.9	Joystick.....	154
5.7.10	Power module	156
5.7.11	Seating module.....	158
5.7.12	Castor light kit.....	161
5.7.13	Mudguard light kit	164
5.7.14	Bumpers for motors	166
5.7.15	Gyro module	168
5.7.16	Light module	171
5.7.17	Legrest cover	174
5.7.18	Legrest actuator.....	176
5.7.19	Excursion metalsheet for legrest.....	178
5.7.20	Spring for legrest	180
5.7.21	Footplate.....	183
5.7.22	Tilt actuator	185
5.7.23	Lift actuator	187
5.7.24	Backrest actuator.....	189
5.7.25	Backrest cover	191
5.7.26	Ruler for armrest adjustment.....	192
5.7.27	Armrest joint.....	194

5.7.28	Armrest	196
6	SPECIFICATIONS	198
6.1	Maximum user weight.....	199
6.2	Other provided information	200
6.3	Dimensions	201
6.3.1	- Version with biomechanical movements.....	201
6.3.2	- Version with biomechanical movements.....	202
7	Warranty terms	203
7.1	Serial number	203

Symbols in this manual



WARNING

This symbol means presence of danger for the user or damage for the product. Always follow instructions when this symbol is present.



PINCH HAZARD

This symbol means presence of pinch hazard.

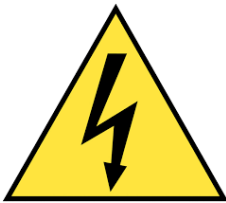

ELECTRICAL WARNING

This symbol means presence of danger related to the presence of electrical energy. Please pay special attention when this symbol is present.



INFORMATION

This symbol means general information intended to simplify or best explain the use of the product.



CONTACT INFORMATION

This symbol means the need of contacting an authorized service center or the manufacturer.



TEMPERATURE

The temperature of some surfaces may increase when the product is exposed to external heat sources as direct sunlight.



TIPPING HAZARD

Tipping hazard is strongly reduced because of the design of the product according to EN 12182.

In any case, please pay special attention during the adjustments and use of the product to prevent any damage to the user or product itself.

Any transport on a slope greater than the maximum safety slope can be dangerous.

Please don't seat on armrests.



ANTI-TIP DEVICES

Using anti-tippers substantially reduces your risk of falling over, which can cause serious injury. The Anti-Tippers will keep you from falling over, but they will limit your ability to be pulled up curbs and some other maneuvers.

IT IS NOT POSSIBLE TO HAVE THIS WHEELCHAIR WITHOUT ANTITIP DEVICES.



Center of balance of the wheelchair and so its stability can be affected by:

- User position
- Use of a backpack
- Tilting of the seat



PINCH HAZARD

Make sure your feet do not hang up or get caught in the space between the footrests. In general, make sure you have proper space in areas you will travel through to minimize pinching or entrapment of body parts.

ELECTROMAGNETIC RADIATION DANGER

The behavior of the wheelchair while driving may be affected by electromagnetic fields created by transceivers such as: Citizens band (CB) radios, walkie-talkies, fire and police radios, cellular phones, lap-top computers, commercial radio and television broadcast antennas. PLEASE USE CAUTION in the presence of these devices.

Electromagnetic radiation can cause your chair, without warning, to:

- release its brakes
- move by itself
- move in unintended directions

If any of these occur, it could result in severe injury to you or others. Electromagnetic radiation can damage the control system of your chair. There is no way to know the effect on electromagnetic immunity if you add accessories or modify this chair. Any change to your chair may increase the risk related to electromagnetic radiation. Parts from other suppliers have unknown electromagnetic properties. **The wheelchair might disturb the operation of devices in its environment.**

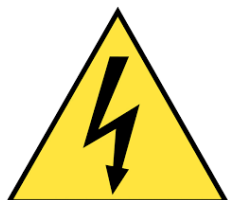

INFORMATION

For information on how to obtain information and instructions in a format appropriate for use by visually impaired people please contact the manufacturer.

Service manual is intended for technical personnel to maintain and repair wheelchairs. It is important to follow the instructions contained in this manual in order to professionally work with the product.

The qualified personnel who works with wheelchairs must comply with all provisions of occupational safety and common sense in order to preserve his own safety.

The manufacturer declines all responsibility for any accidents occurring during the working with the product.

WARNING: It is prohibited to use the product or its parts for any purpose other than that indicated. For a correct use please follow the instructions given in this manual. The manufacturer disclaims any responsibility for damages caused by improper use of the product.

The manufacturer disclaims any responsibility for inappropriate selection of product model and configuration.

Information in this manual may be subject to change without notice. All information, pictures and specifications are based on the product details that were available at the time of preparation of this document. They are representative examples and they are not intended to be exactly as the actual product.

MODIFICATIONS

Any unauthorized modification to the product may increase the risk of personal injury and damage to the product itself. All modifications should be done by an authorized service center.

Do not use any unauthorized accessories or spare parts on the product. Do not use the product in combination with other medical devices without first having considered any risk due to combination of more products.

MANUFACTURER

For any need not expressly explained in this manual, please contact the manufacturer.

Neatech.it SRL

via A. de Curtis 4/A, 80040, Cercola (NA), Italy

www.neatech.it – info@neatech.it - +39 081 555 1946

INCIDENT REPORTING

If an incident occurs, please contact an authorized service center. For a list of authorized service center please contact the manufacturer.



DISPOSING

This product and all its components can not be treated as household waste. For more detailed information on how recycling and disposal this product contact your local waste disposal service.

1 PRODUCT INFORMATION

The EVO 3 offers a sleek design and superior performance, the top of its category, providing a perfect combination of stability and maneuverability.

Born from the passion of Neatech for high engineering, which allows it to offer a broader spectrum of choices than in the past; it is a quality product that features an elegant design and performance.

Total length	1100 mm
Total width	MIN 560 mm – MAX 615 mm
Seat height	MIN 460 mm – MAX 480 mm
Total wheelchair weight	MAX 125 kg
Maximum user weight	MAX 80 kg
Seat width	MIN 300 mm – MAX 420 mm
Batteries	2x 55 Ah GEL
Charger	6 A
Power module	Rnet 80 A
Motors	2x 220 W

2 PREPARATION FOR FIRST USE

2.1 Checks to be made on delivery

- Check for the integrity of the original packaging.
- Check for any anomalies on shipping documents.
- Check for the functionality and integrity of the device in all its parts, at the time of delivery or immediately thereafter, to ensure that no damage has resulted from a careless transport.
- Make sure the surface of the device is not damaged, scratched, bent, etc.
- Any fault or damage found must be immediately reported on the shipping documents and promptly communicated to the shipper.

2.2 Unpacking

Inside the box there are:

- Evo3 wheelchair
- Documents and manual
- Charger

The wheelchair is delivered already mounted and ready to use. Before starting to use the wheelchair please check if all described components are present. **If not, please contact as soon as possible the vendor.**



PACKAGING DISPOSAL

To properly recycle the packaging materials follow instructions provided by your local waste disposal service.

2.1 Software description

The software of the wheelchair can be categorized into these classes:

- Kernel software of power module.

There is no required access, modification or customization of this part of the software



In case a reprogramming of the wheelchair is required, please contact the manufacturer to have instructions and the most suitable version of the software.

In case of problems with this part of the software please contact the manufacturer.

- Kernel software of seating module.

There is no required access, modification or customization of this part of the software



In case a reprogramming of the wheelchair is required, please contact the manufacturer to have instructions and the most suitable version of the software.

In case of problems with this part of the software please contact the manufacturer.

- Software parameters of the wheelchair.

This part of the software is made by the manufacturer. It is intended to assure driving and seating function of the wheelchair. It is responsibility of the manufacturer to correct program parameters regarding the structure of the wheelchair.

Qualified personnel of an authorized service center are able to customize this part of the software to best fulfill single user requirements.



Programming must be conducted only by qualified personnel with in-depth knowledge of the wheelchair and power module system.
Any change to this part of the software may result in a hazardous situation for the user.

2.1.1 Rnet system: OBP onboard programming

Onboard programming allows the wheelchair to be programmed via the Joystick Module. Turn off the wheelchair. Insert the Rnet dongle along the communication cables in the system. Turn on the control system. After initialization, reboot the wheelchair. Press the Mode key until the OBP screen is reached. **For more information, see Rnet manual.**



Programming must be conducted only by qualified personnel with in-depth knowledge of the wheelchair and power module system.
Any change to this part of the software may result in a hazardous situation for the user.



To manage this part of the software it is required a Rnet Dongle made by Penny & Giles and some special software.
Please contact the manufacturer for more information.

2.1.2 Rnet system: PC programming



Programming must be conducted only by qualified personnel with in-depth knowledge of the wheelchair and power module system. Any change to this part of the software may result in a hazardous situation for the user.



To manage this part of the software it is required a Rnet Dongle made by Penny & Giles and some special software.
Please contact the manufacturer for more information.



To know the latest version of wheelchair parameters and for more information please contact the manufacturer.

Software setup

[SKIP THIS POINT IF YOU ALREADY INSTALLED THE LATEST VERSION OF RNET SOFTWARE OEM_GENERIC]



To know the latest version of RNET software please contact the manufacturer.

Please lunch setup application and follow showed indications.

[SKIP THIS POINT IF YOU ALREADY INSTALLED THE LATEST VERSION OF RNET SOFTWARE OEM_NEATECH]



To know the latest version of RNET software please contact the manufacturer.

Please lunch setup application and follow showed indications.

Programming the wheelchair - Drive parameters

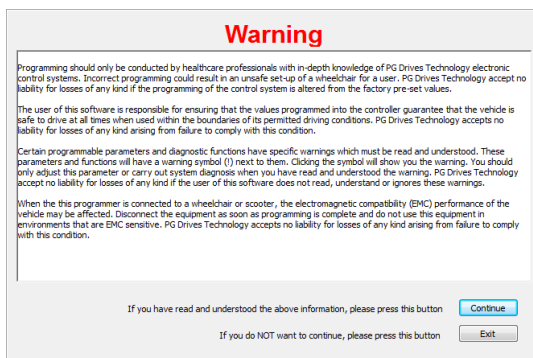

Figure 1

- Start the application PG DRIVES TECHNOLOGIES >> R NET PROGRAMMER >> OEM GENERIC >> PROGRAMMER
- Click CONTINUE to actually start the application.

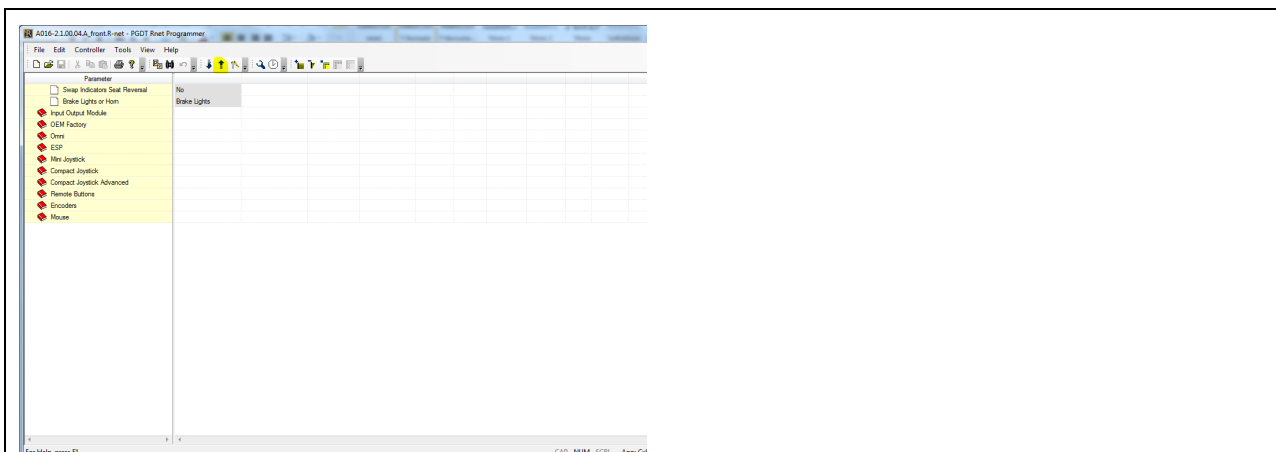

Figure 2

- Click FILE>>OPEN and select the desired programming file or read parameters from the wheelchair by clicking on the DOWN arrow.
- **Connect the Rnet Dongle to the PC and to the wheelchair. For more information, see Rnet manual.**
- Customize desired parameters.
- When finished turn on the wheelchair and click on the UP arrow to write the parameters in the wheelchair.

Programming the wheelchair - CxSM programming

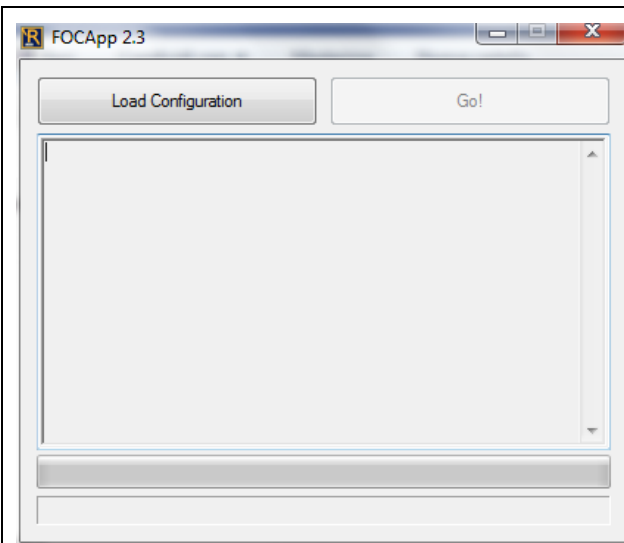

Figure 3

- Open the application FOCApp.

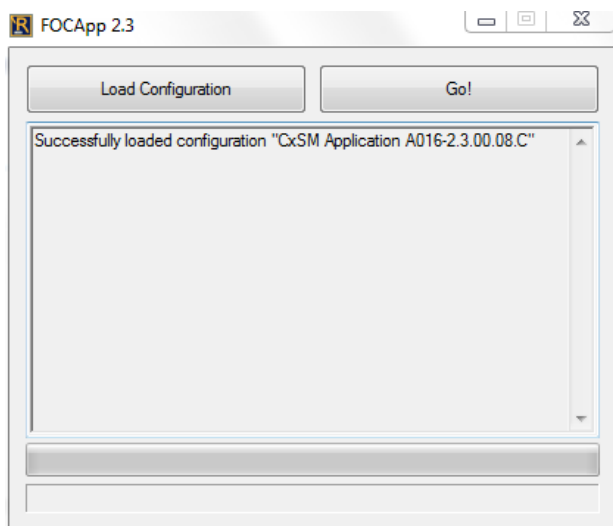

Figure 4

- Click LOAD CONFIGURATION and select the desired FOC file.
- **Connect the Rnet Dongle to the PC and to the wheelchair. For more information, see Rnet manual.**

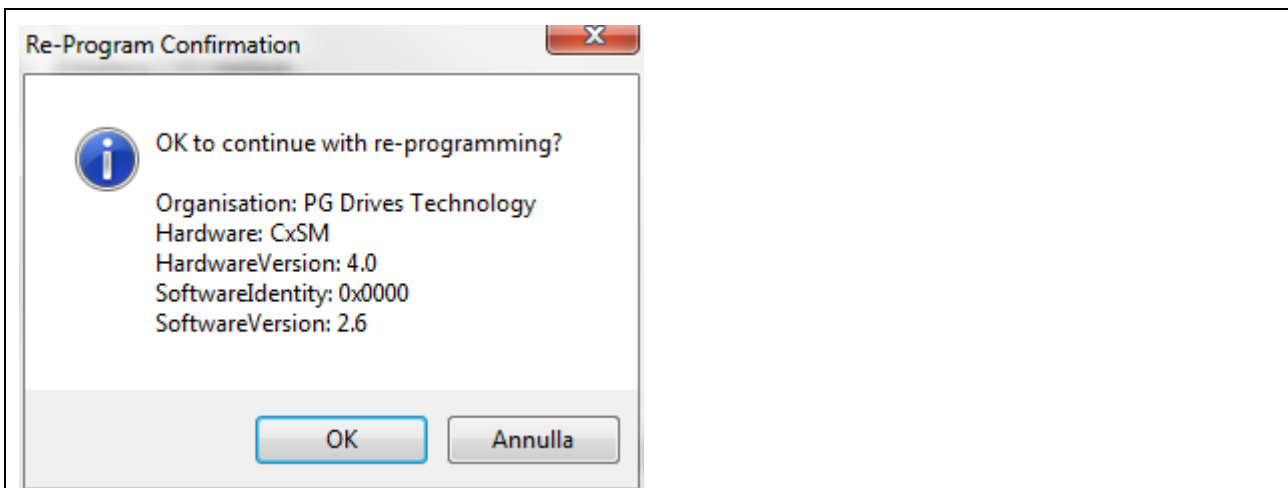

Figure 5

- Click GO
- Sometimes it may occur an error. In this case click GO again.
- Click OK

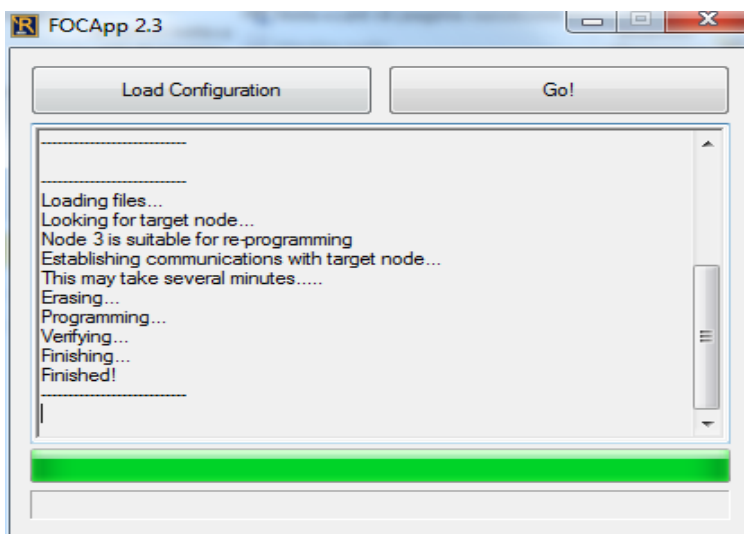

Figure 6

- Wait for the upgrade to be finished. During the operation the wheelchair may turn off.
- When finished, close the application.
- Turn on the wheelchair and reboot it.

Programming the wheelchair - Seat parameters

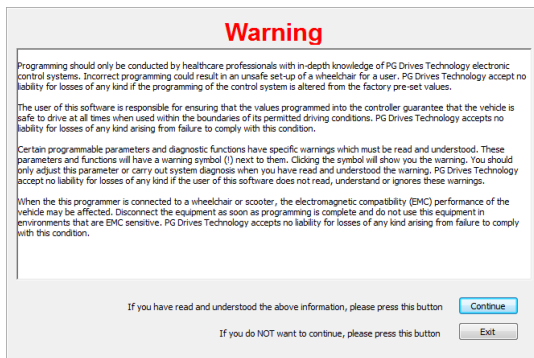

Figure 7

- Start the application PG DRIVES TECHNOLOGIES >> R NET PROGRAMMER >> OEM NEATECH >>PROGRAMMER
- Click CONTINUE to actually start the application.

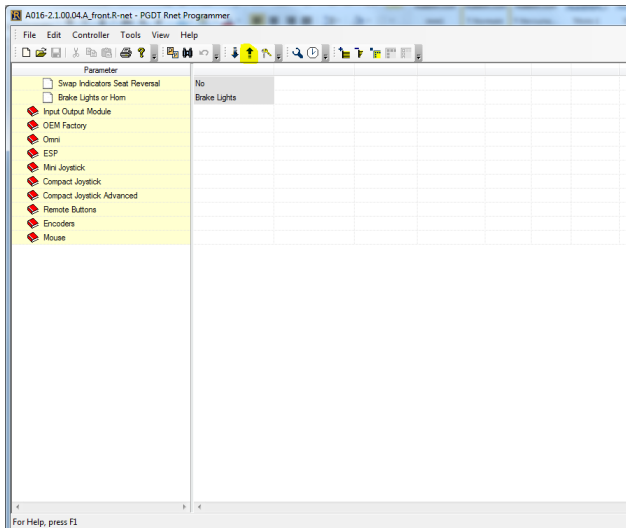

Figure 8

- Click FILE>>OPEN and select the desired programming file or read parameters from the wheelchair by clicking on the DOWN arrow.
- **Connect the Rnet Dongle to the PC and to the wheelchair. For more information, see Rnet manual.**
- Customize desired parameters.
- When finished turn on the wheelchair and click on the UP arrow to write the parameters in the wheelchair.

3 ADJUSTMENTS

3.1 Seating system description

- **Seat height (B):** this is the height of seat measured starting from the chassis (**line a**). When seat angle is different from zero, you should have two different values for front and back seat height.

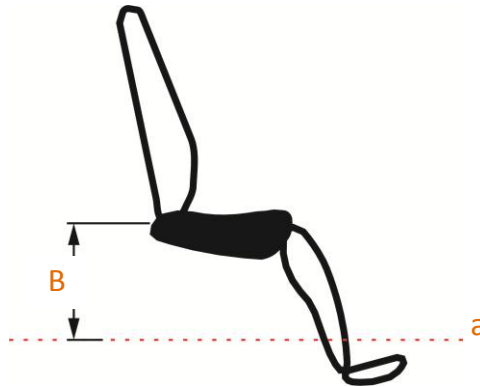

Figure 9

- **Seat angle (C):** this is the angle between the seat and the chassis (**line a**). Seat angle is positive when the seat is tilted rearward, zero when the seat is horizontal and negative when the seat is tilted forward.
- **Absolute backrest angle (D):** this is the angle between the backrest and the seat.
- **Backrest angle (E):** this is the angle between the backrest and the chassis of the wheelchair (**line a**). Only when seat angle is zero, absolute backrest angle is equal to backrest angle.

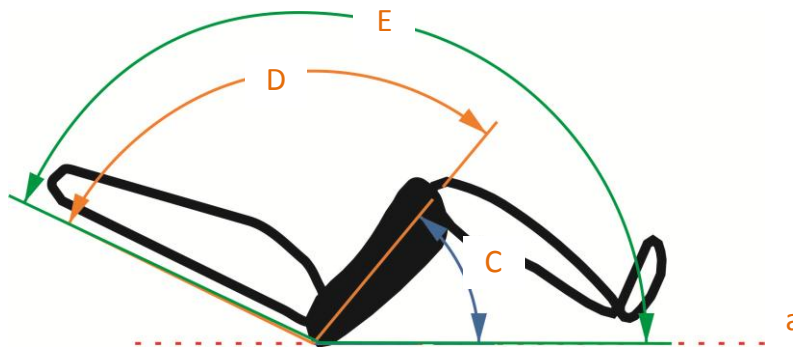

Figure 10

- **Absolute legrest angle (F):** this is the angle between the legrest and line perpendicular to the seat (**g**).
- **Legrest angle (H):** this is the angle between the legrest and the line perpendicular to the chassis of the wheelchair (**line m**). Only when seat angle is zero, absolute legrest angle is equal to legrest angle.

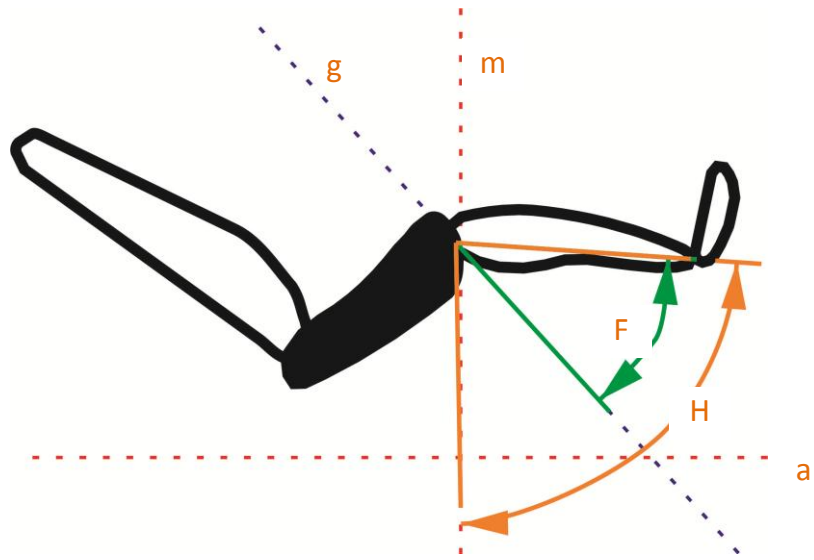

Figure 11

3.2 Powered functions



WARNING

Operating these functions changes the center of gravity and increases the risk of tipping over.

Always drive in low speed when the seating system is not in the default position. Use these functions only on horizontal plane.

To enter seating mode use MODE function of the joystick.

A wheelchair will appear on the screen of the joystick.

To select the desired function move the joystick left or right.

The number and the type of available function may change according to the specific customization of each wheelchair.

MOVE UP

Move the joystick forward while you are in seating mode and the desired function is selected

MOVE DOWN

Move the joystick rearward while you are in seating mode and the desired function is selected

It is possible to customize seating functions according to indications in following sections. For more information about the actual programming of the wheelchair see section 2.1.2 .

PARAMETER	DEFAULT	RANGE
PG1 - Maximum Backrest Angle	180	90-180
PG4 - Minimum Backrest Angle	90	90-180 <=Maximum Backrest Angle
PG2 - Maximum Negative Legrest Angle	90	0-90
PG5 - Maximum Legrest Inclination	NOT USED	
PG6 - Legrest Length	36	30-50
PG3 - Maximum Negative Tilt	0	0
PG7 - Maximum Positive Tilt	NOT USED	
PG8 - User Weight	NOT USED	

Table 1

	Axis 1	Axis 2	Axis 3	Axis 4	Axis 5	Axis 6	Axis 7	Axis 8	Axis 9	Axis 10	Axis 11	Axis 12
Maximum Backrest Angle	0											
Minimum Backrest Angle	0											
Maximum Negative Legrest Angle	0											
Maximum Legrest Inclination	0											
Legrest Length	0											
Maximum Negative Tilt	0											
Maximum Positive Tilt	0											
User Weight	0											
Parameter 1	0	0	0	0	0	0	0	0	0	0	0	0
Parameter 2	0	0	0	0	0	0	0	0	0	0	0	0
Parameter 3	0	0	0	0	0	0	0	0	0	0	0	0
Parameter 4	0	0	0	0	0	0	0	0	0	0	0	0

Figure 12



Programming must be conducted only by qualified personnel with in-depth knowledge of the wheelchair and power module system.
Any change to this part of the software may result in a hazardous situation for the user.

3.2.1 AXIS 1: Backrest

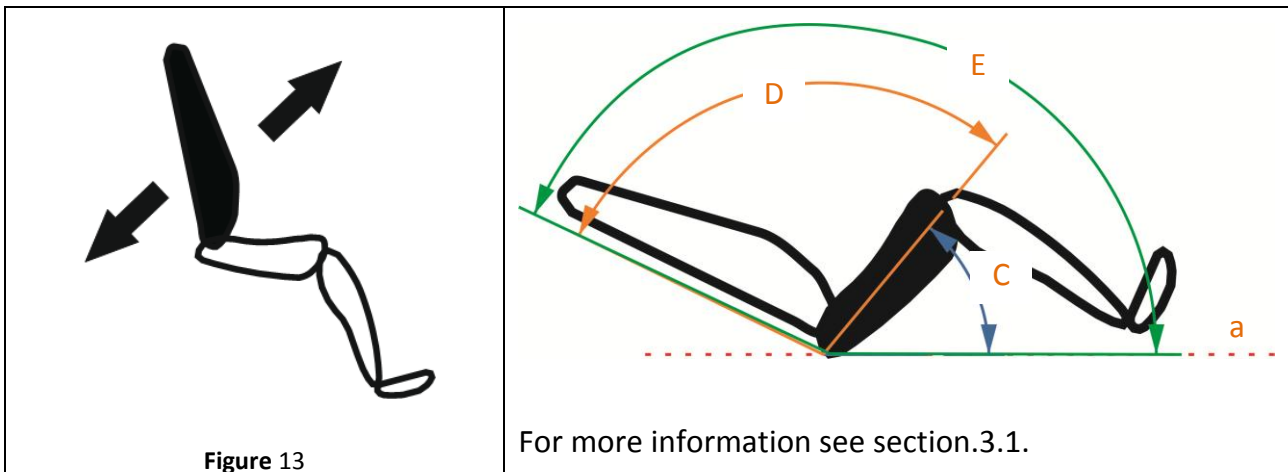

MOVE UP

It is possible to recline forward the backrest. The movement stops when backrest angle (E) is equal to PG4 (Minimum backrest angle). When the movement stops, you will hear a sound.

MOVE DOWN

You can recline rearward the backrest. The movement stops when backrest angle (E) is greater than PG1 (Maximum backrest angle). When the movement stops you will hear a sound.

AXIS 1 PARAMETERS .

Parameter	Default	Range
Parameter 1	NOT USED	
Parameter 2	NOT USED	
Parameter 3	NOT USED	
Parameter 4	NOT USED	

Table 2



WARNING

Operating these functions changes the center of gravity and increases the risk of tipping over.

Always drive in low speed when the seating system is not in the default position. Use these functions only on horizontal plane.

3.2.2 AXIS 2: Legrest

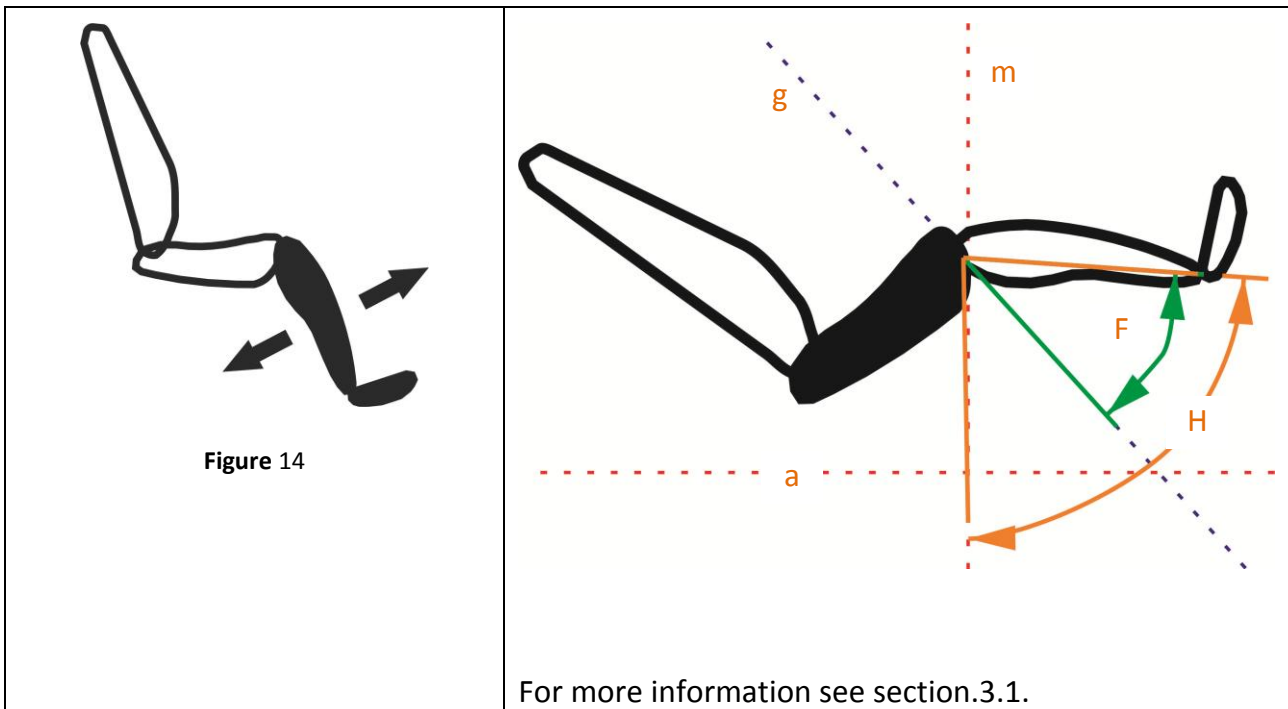

MOVE UP

It is possible to move up legrest. The movement stops when legrest angle (H) or absolute legrest angle (F) are equal to 90° . When the movement stops, you will hear a sound.

MOVE DOWN

You can lower rearward legrest. The movement stops when legrest angle (H) is greater than PG2 (Maximum Negative Legrest Angle) or absolute legrest angle (F) is greater than 90° . When the movement stops you will hear a sound.

AXIS 2 PARAMETERS .

Parameter	Default	Range
Parameter 1	NOT USED	
Parameter 2	NOT USED	
Parameter 3	NOT USED	
Parameter 4	NOT USED	

Table 3

WARNING



Previously to move the legrest (both forward and rearward) the software checks for any danger of crashing the legrest into the floor. If any danger is found the seat will automatically lift.

In order to calculate the risk of crashing into the floor for the legrest the software uses the parameter PG6 (legrest length) and assumes that the wheelchair is on a perfectly flat surface far from any step or obstacle. For these reasons it is very important to:

- Set correctly the value of parameter PG6 (legrest length) with the correct length of the legrest expressed in cm.
- Do not use the legrest function on a non-flat surface or near steps or obstacles.

WARNING



The legrest is a biomechanical legrest: this means that its length changes during elevation to take into account the different position of the center of knee and the center of the legrest. In order to correctly set the parameter PG6 (legrest length) it is necessary to measure the legrest when it is completely closed. Please take into account that you must consider the global length of the legrest including footrests and any other accessories.

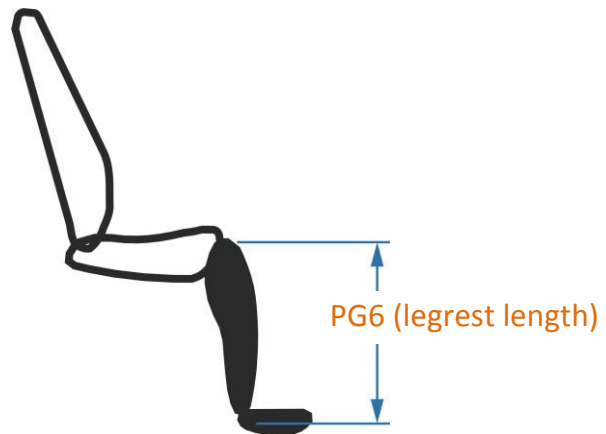
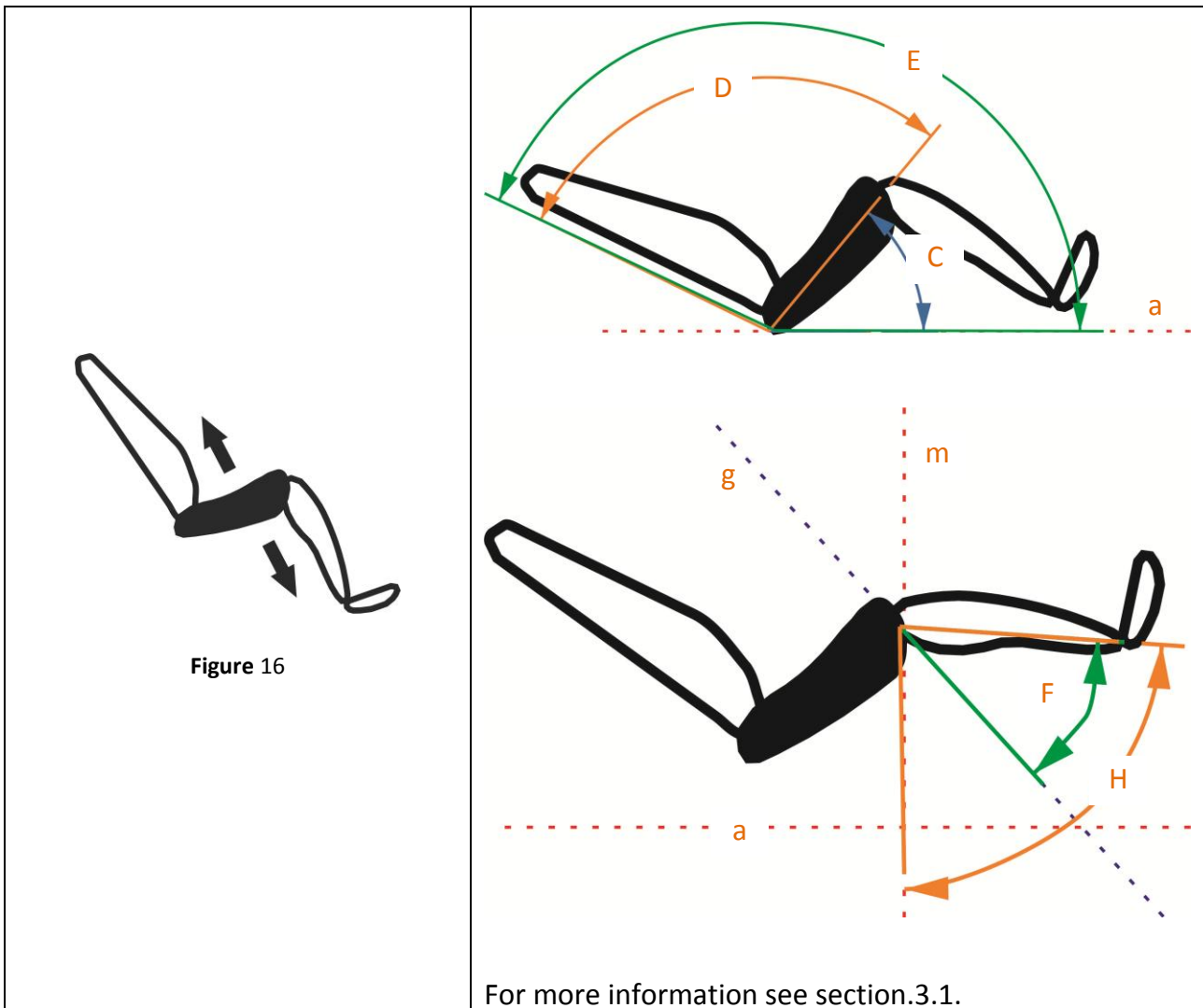

Figure 15

3.2.3 AXIS 3: Tilt



MOVE UP

It is possible to move forward the seat. The movement stops when seat angle (C) is 0° . When the movement stops, you will hear a sound.

MOVE DOWN

It is possible to move rearward the seat. The movement stops when seat angle (C) is 45° . If the seat is forward tilted the movement will stop when seat angle (C) is 0° . When the movement stops, you will hear a sound.

If during the movement backrest angle (E) will be greater than PG1 (maximum backrest angle), the backrest will automatically close in order to prevent any uncomfortable position for the user. If during the movement legrest angle (H) will be 0° , legrest will automatically close in order to prevent any uncomfortable position for the user.

AXIS 3 PARAMETERS .

Parameter	Default	Range
Parameter 1	USED FOR LIFT FUNCTION (AXIS 4).	
Parameter 2	USED FOR LIFT FUNCTION (AXIS 4).	
Parameter 3	USED FOR LIFT FUNCTION (AXIS 4).	
Parameter 4	USED FOR LIFT FUNCTION (AXIS 4).	

Table 4

3.2.4 AXIS 4: Lift

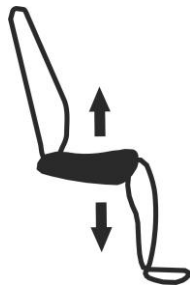
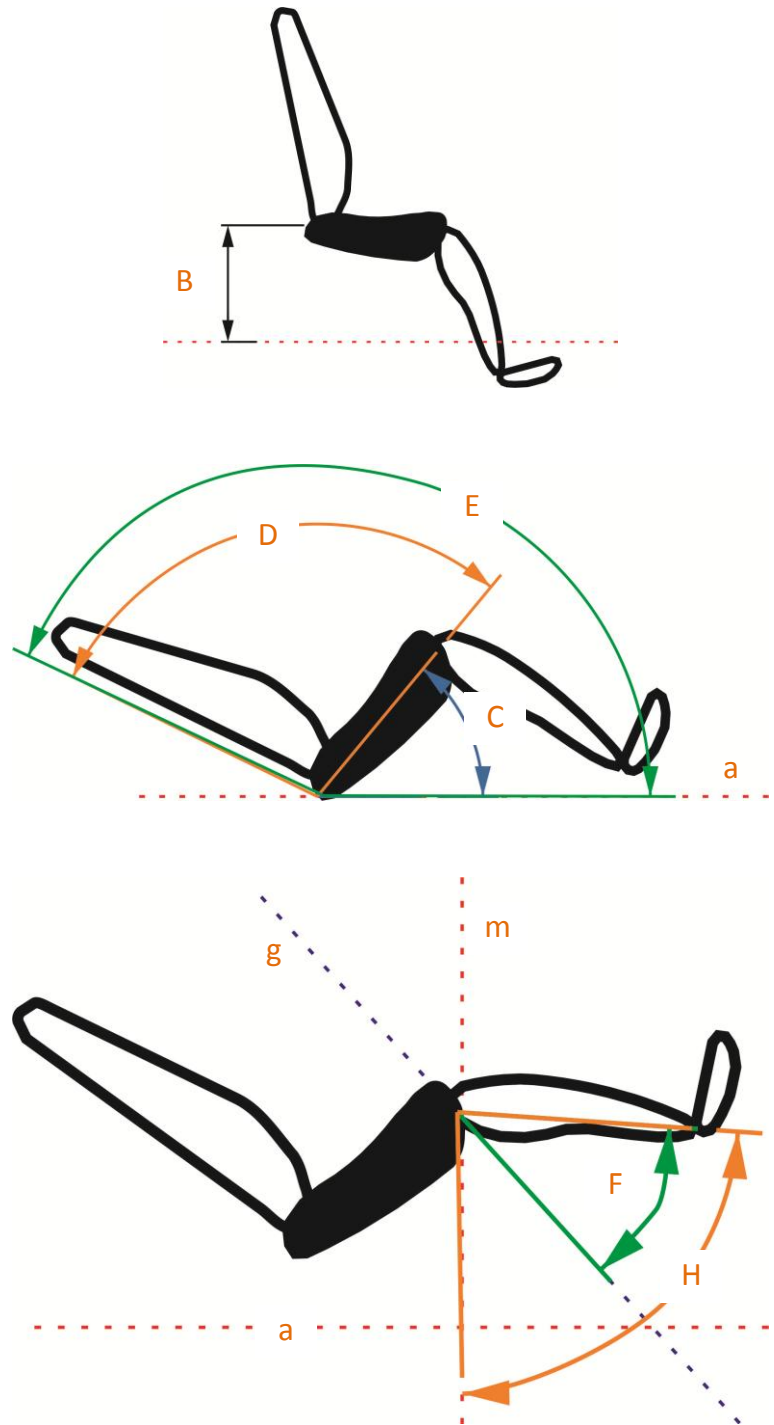

Figure 17



For more information see section.3.1.

MOVE UP

If seat angle (C) is negative, firstly the seat is straightened. After this, the seat is lifted. When seat height (B) is 30 cm, if seat angle (C) is 0° the movement stops, otherwise the seat will be straightened till seat angle (C) is 0°. When the movement stops, you will hear a sound.

The movement is performed moving two different actuators at the same time. In order to adjust their speed there is a PID software function.

Parameter 1 (axis 3) is the endstop limit for the first actuator (the one on the right). Parameter 2 (axis 3) is the endstop limit for the second actuator (the one on the left). Parameter 3 (axis 3) is the setpoint of the PID. Parameter 4 (axis 3) is the k factor of the PID.

MOVE DOWN

It is possible to lower the seat. Previously to permit the movement the software check for any risk for the legrest to crash into the chassis or into the floor. In case of danger of a crash into the chassis, legrest will automatically open till legrest angle (H) is smaller than PG2 (maximum negative legrest angle). In case of a danger of a crash into the floor, the seat will be tilted rearward. When seat height (B) is 0 cm, if seat angle (C) is 0°, the movement stops, otherwise the seat will be straightened till seat angle (C) is 0°. When the movement stops, you will hear a sound.

AXIS 3 PARAMETERS .

Parameter	Default	Range
Parameter 1	240	0-250
Parameter 2	240	0-250
Parameter 3	1	0-100; Setpoint forward 100-200 Setpoint rearward
Parameter 4	105	0-100; k positive 100-200 k negative

Table 5

AXIS 4 PARAMETERS .

Parameter	Default	Range
Parameter 1	4	0-50
Parameter 2	2	0-50
Parameter 3	1	0-100; Setpoint forward 100-200 Setpoint rearward
Parameter 4	105	0-100; k positive 100-200 k negative

Table 6

3.2.5 AXIS 5: Rehab

MOVE UP

Firstly the seat is straightened till seat angle is 0° . After this, the wheelchair goes into the LAYDOWN position. It is possible to choose the height of the seat. Use Parameter 1 to set the desired height expressed in cm.



Figure 18

After this the seat will automatically go in the position shown in figure.

If the wheelchair is already forward tilted, it will go directly in the position shown in figure. If during the movement the software find any risk for the legrest to crash into the floor the seat will automatically lifted.

It is possible to choose the angle of the seat (N) from the chassis (line a). Use Parameter 2 to set the desired angle expressed in degrees.

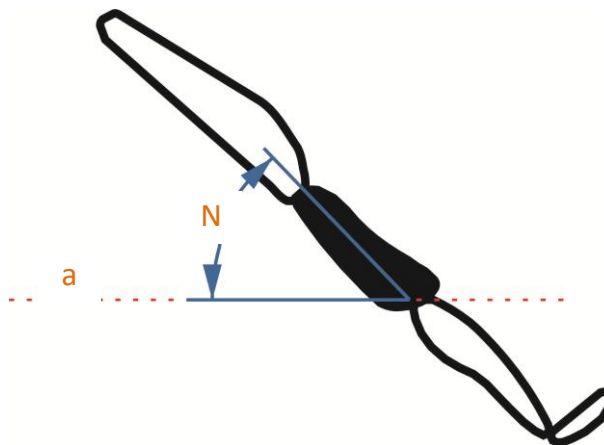

Figure 19

MOVE DOWN

It is possible to bring the wheelchair in the default position. If the seat is forward tilted, firstly the wheelchair will go into the position shown in figure.



Figure 20

After this the wheelchair will go automatically in the default position shown in figure. If the seat isn't forward tilted, the wheelchair will go directly into the default position shown in figure.

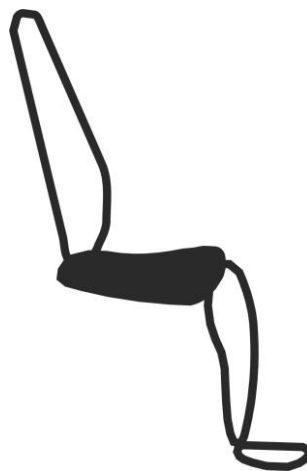

Figure 21

AXIS 5 PARAMETERS .

Parameter	Default	Range
Parameter 1	50	25-125
Parameter 2	25	5-30
Parameter 3	NOT USED	
Parameter 4	NOT USED	

Table 7

3.2.6 AXIS 6: Active negative tilt

MOVE UP

The wheelchair will automatically go into the position shown in figure. During the movement the software checks for any danger for the legrest to crash into the floor. If any risk is revealed the seat will automatically lift.

Seat angle (C) is: -15° (seat forward tilted).

It is possible to choose the angle of backrest from the seat (P). Use Parameter 1 to set the desired angle expressed in degrees.

It is possible to choose the absolute legrest angle (Q). Use Parameter 2 to set the desired angle expressed in degrees.

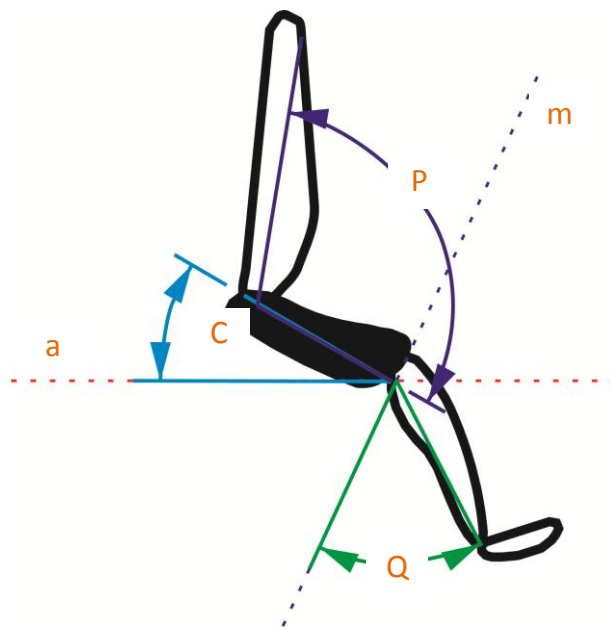

Figure 22

After this the seat will automatically go in the default position shown in figure. **MOVE DOWN**
 It is possible to bring the wheelchair in the default position. If the seat is forward tilted, firstly the wheelchair will go into the position shown in figure.

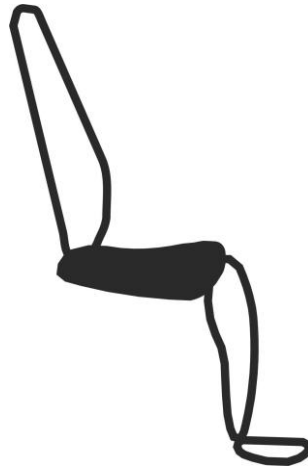

Figure 23

AXIS 6 PARAMETERS .

Parameter	Default	Range
Parameter 1	90	900-120 >= PG4Minimum Backrest Angle
Parameter 2	75	70-90
Parameter 3	NOT USED	
Parameter 4	NOT USED	

Table 8

3.2.7 AXIS 7: Semistanding

MOVE UP

The wheelchair will automatically go into the position shown in figure. During the movement the software checks for any danger for the legrest to crash into the floor. If any risk is revealed the seat will automatically lift.

Seat is forward tilted of 25°.

It is possible to choose the absolute backrest angle (R). Use Parameter 1 to set the desired angle expressed in degrees.

It is possible to choose the absolute legrest angle (S). Use Parameter 2 to set the desired angle expressed in degrees.

It is possible to choose the front seat height (T). Use parameter 3 to set the desired angle expressed in degrees.

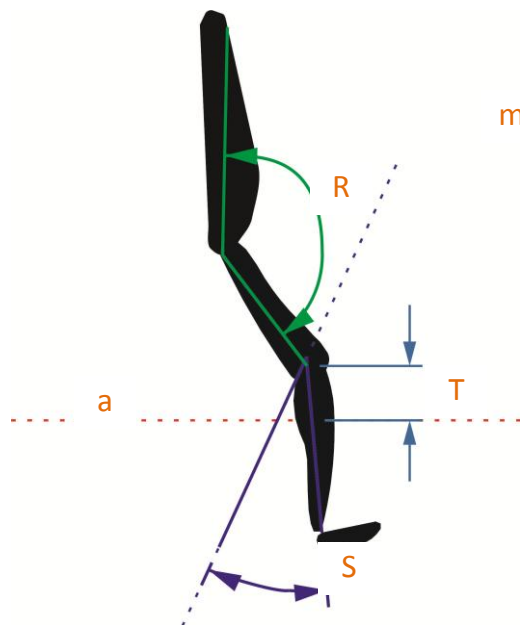

Figure 24

After this the seat will automatically go in the default position shown in figure. **MOVE DOWN**
 It is possible to bring the wheelchair in the default position. If the seat is forward tilted, firstly the wheelchair will go into the position shown in figure.

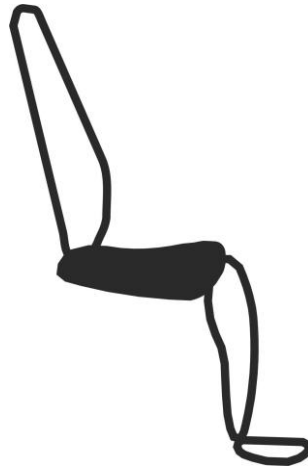

Figure 25

AXIS 7 PARAMETERS .

Parameter	Default	Range
Parameter 1	120	90-120 >= Minimum Backrest Angle
Parameter 2	55	70-80
Parameter 3	10	5-100
Parameter 4	NOT USED	

Table 9

3.2.1 AXIS 8: Laydown

MOVE UP

The wheelchair will automatically go into the position shown in figure.

It is possible to choose the seat height. Use Parameter 1 to set the desired height expressed in cm.



Figure 26

After this the seat will automatically go in the default position shown in figure. **MOVE DOWN**

It is possible to bring the wheelchair in the default position. If the seat is forward tilted, firstly the wheelchair will go into the position shown in figure.



Figure 27

AXIS 8 PARAMETERS .

Parameter	Default	Range
Parameter 1	50	0-200
Parameter 2	NOT USED	
Parameter 3	NOT USED	
Parameter 4	NOT USED	

Table 10

3.3 Speed limitations



Programming must be conducted only by qualified personnel with in-depth knowledge of the wheelchair and power module system.
Any change to this part of the software may result in a hazardous situation for the user.

The maximum speed of the wheelchair is automatically limited according to the position of the seating system. There are four different bands. To set the speed reduction in each band set the specific values in the rows shown in figure. In order to find this section, open the programmer software and go into the section INHIBITS>DRIVE INHIBITS. For more information see section 2.1.2 .

	A	B	C	D	E
Drive Inhibits					
<input type="checkbox"/> Assign	31	Off	Off	Off	Off
<input type="checkbox"/> Speed Limit in Band 0	100 %	0 %	50 %	100 %	100 %
<input type="checkbox"/> Speed Limit in Band 1	50 %	100 %	100 %	100 %	100 %
<input type="checkbox"/> Speed Limit in Band 2	50 %	100 %	100 %	100 %	100 %
<input type="checkbox"/> Speed Limit in Band 3	0 %	100 %	100 %	100 %	100 %
<input type="checkbox"/> Operation	Non-latching	Non-latching	Non-latching	Non-latching	Non-latching
<input type="checkbox"/> Inhibit Alarm	No	No	No	No	No

Figure 28

The wheelchair is considered in BAND 1 when one of following conditions occurs: the height of seat is higher than the value set in Parameter 1 - Axis 12; the angle of the seat is greater than the value set in Parameter 3 - Axis 12; the seat is forward tilted with an angle of more than 10° (Seat angle<-10). The wheelchair is considered in BAND 2 when one of following conditions occurs: the height of the seat is more than the value set in Parameter 2 - Axis 12; the seat is forward tilted of more than 20° (Seat angle<-20). The wheelchair is in BAND 3 when there is the possibility for legrest to crash into the floor. **As default the speed is limited at 0%. Please don't change this value.**



Modify only parameters in:
SPEED LIMIT IN BAND 0
SPEED LIMIT IN BAND 1
SPEED LIMIT IN BAND 2
Do not modify any other parameter in this section.

AXIS 12 PARAMETERS .

Parameter	Default	Range
Parameter 1	60	1-65
Parameter 2	200	2-250 >Parameter 1
Parameter 3	20	0-25
Parameter 4	NOT USED	

Table 11

	Axis 1	Axis 2	Axis 3	Axis 4	Axis 5	Axis 6	Axis 7	Axis 8	Axis 9	Axis 10	Axis 11	Axis 12
Maximum Backrest Angle	0											
Minimum Backrest Angle	0											
Maximum Negative Legrest Angle	0											
Maximum Legrest Inclination	0											
Legrest Length	0											
Maximum Negative Tilt	0											
Maximum Positive Tilt	0											
User Weight	0											
Parameter 1	0	0	0	0	0	0	0	0	0	0	0	0
Parameter 2	0	0	0	0	0	0	0	0	0	0	0	0
Parameter 3	0	0	0	0	0	0	0	0	0	0	0	0
Parameter 4	0	0	0	0	0	0	0	0	0	0	0	0

Figure 29

3.4 List of adjustments

Type of operation	
A	Operation intended to be performed by the user.
B	Operation intended to be performed by an assistant.
C	Operation intended to be performed by an authorized service center.

Table 12

3.4.1 Version of the wheelchair with biomechanics movements

Adjustment	Section	Type of operation
Seat depth	3.5	C - Service
Armrests depth	3.6	B - Assistant
Armrests height	3.7	B - Assistant
Horizontal armrest angle	3.9	B - Assistant
Vertical armrest angle	3.8	B - Assistant
Footplates height	3.10	C - Service
Backrest height	3.11	B - Assistant
Joystick position	3.12	B - Assistant

Table 13

3.4.2 Version of the wheelchair without biomechanics movements

Adjustment	Section	Type of operation
Seat depth	3.13	B - Assistant
Backrest angle	3.14	B - Assistant
Armrests depth	3.15	B - Assistant
Armrests height	3.16	B - Assistant
Sidepad height	3.17	B - Assistant
Footplates height	3.18	B - Assistant
Footplates angle and depth	3.19	B - Assistant
Joystick position	3.20	B - Assistant

Table 14

3.5 Seat depth - Version with biomechanical movements

	WHEELCHAIR SIZE	(A) MIN VALUE	(A) MAX VALUE	PG1 (max backrest angle)
	M1 - S042-V073	300 mm	420 mm	155°
M2 - S042-V074	300 mm	460 mm	155°	
M3 - S042-V075	300 mm	485 mm	155°	
	485 mm	500 mm	170°	
M4 - S042-V071	30.0 mm	485 mm	155°	
	485 mm	520 mm	170°	

Table 15



WARNING

It is needed to set separately left and right seat depth. Always set them at the same manner.

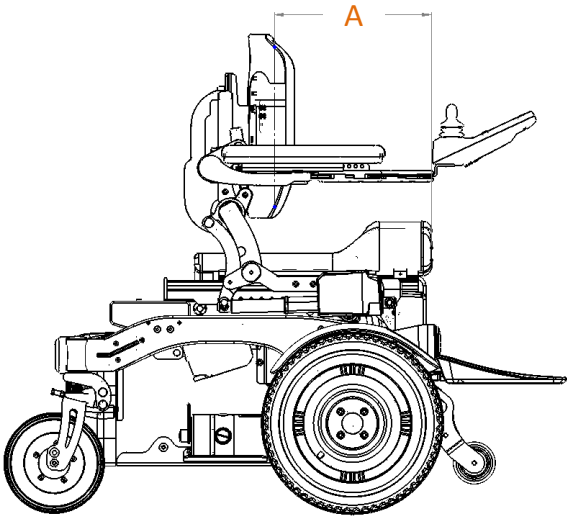

WARNING

When performing this adjustment, it may be needed to adjust again PG1 (maximum backrest angle). For more information see section 3.2.



Average needed time:
5 min



Difficulty level:
Easy

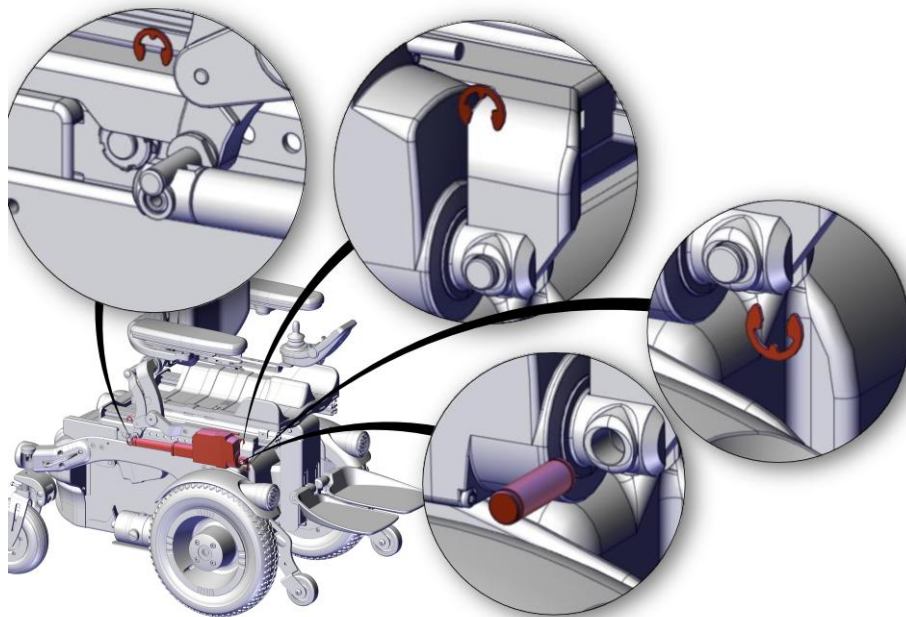

Figure 30

- Remove the 3 Seegers shown in figure. Use a screwdriver as a lever.
- Remove the axis shown in figure.
- Remove the actuator.

SCREWDRIVER

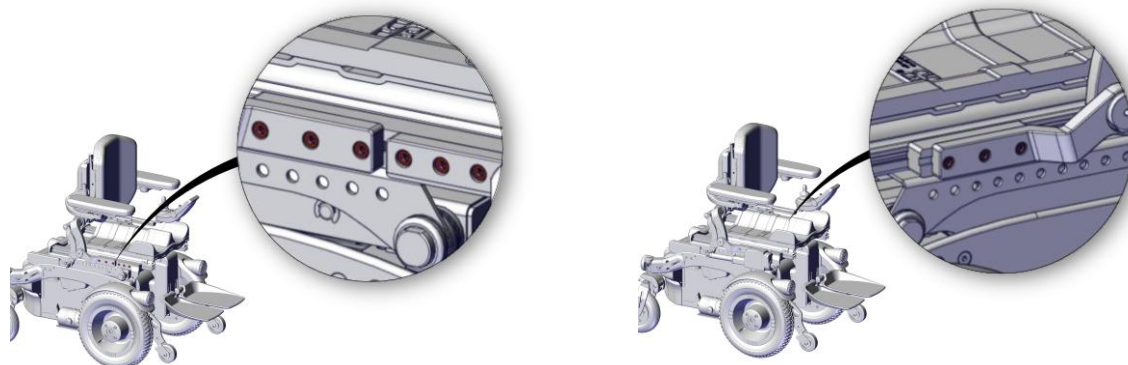

Figure 31

- Loosen the 9 screws shown in figure. 6 of them are on the right side of the wheelchair and the other 3 are on the left side of it.
- Set the seat depth as desired.
- Tighten again the 9 screws.
- Mount again the axis, the seeger and the actuator following instructions in reverse order.

ALLEN WRENCH



5 mm

3.6 Armrests depth - Version with biomechanical movements

	WHEELCHAIR SIZE	(A) MIN VALUE	(A) MAX VALUE
	S042-V401 S042-V403	200 mm	280 mm
	S042-V402 S042-V404	280 mm	360 mm

Table 16



RIGHT AND LEFT SIDE

It is possible to adjust separately left and right side.

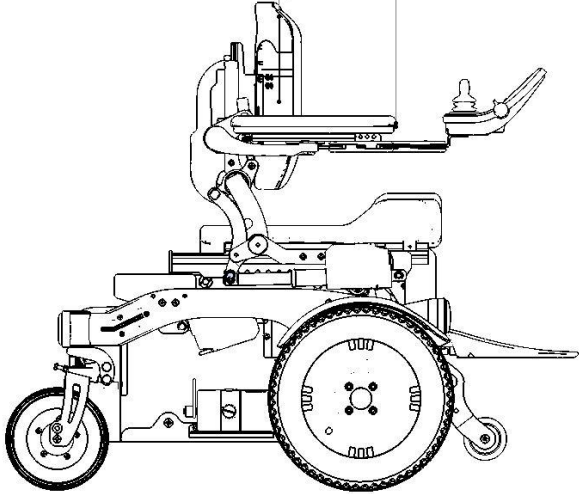

Average needed
time:

<5 min



Difficulty level:

Easy

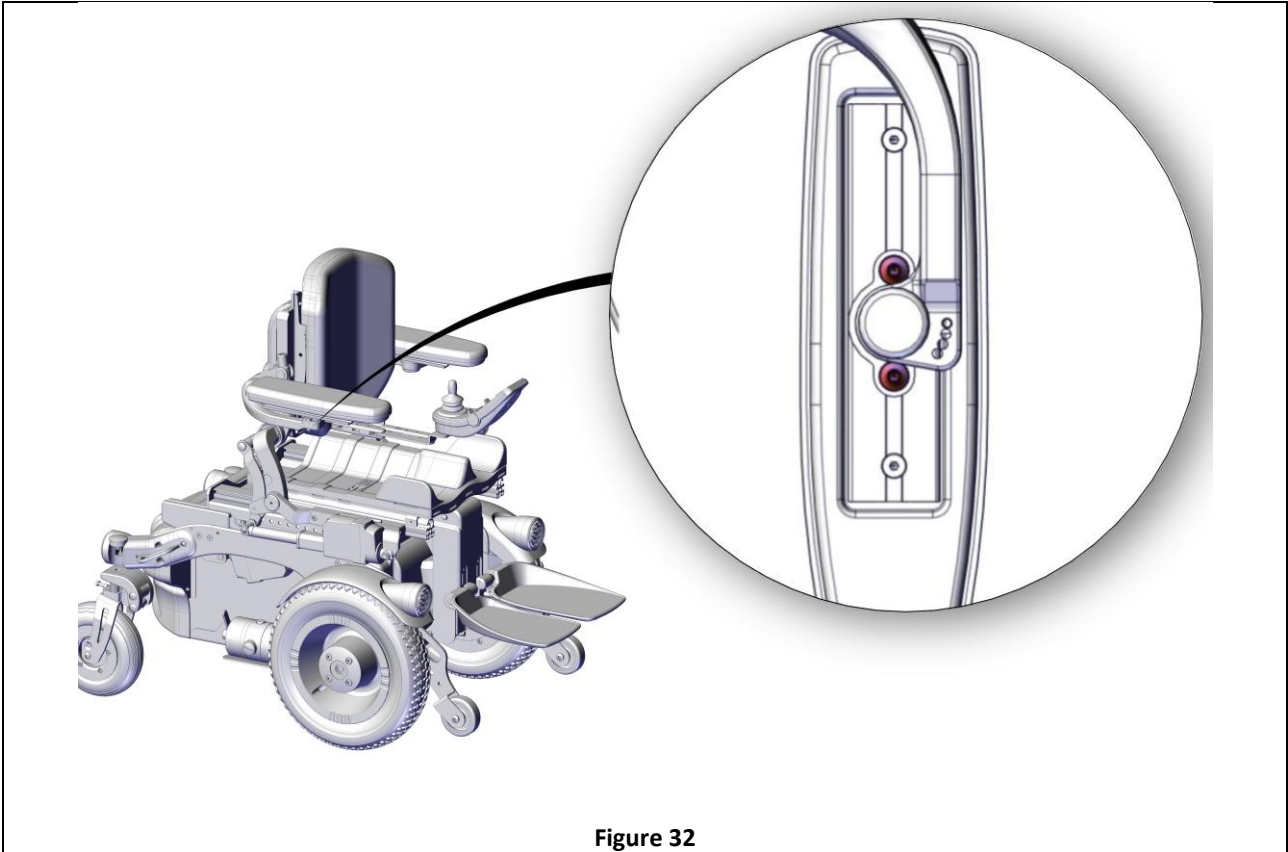

Figure 32

- Loosen the 2 screws shown in figure.
- Adjust the depth as desired.
- Tighten again the screws.

ALLEN WRENCH



5 mm

3.7 Armrests height - Version with biomechanical movements



RANGE

It is not easy to provide a range for this adjustment because there are too many configuration and possibilities.



Average needed
time:
<5 min



Difficulty level:
Easy



WARNING

As this adjustment is carried out, it is necessary to compensate by adjusting also the armrest vertical angle.

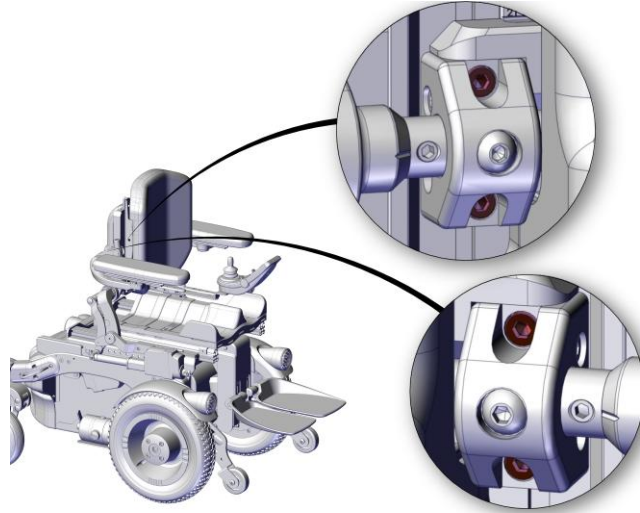

Figure 33

- Loosen the 4 screws shown in figure.

ALLEN WRENCH



5 mm

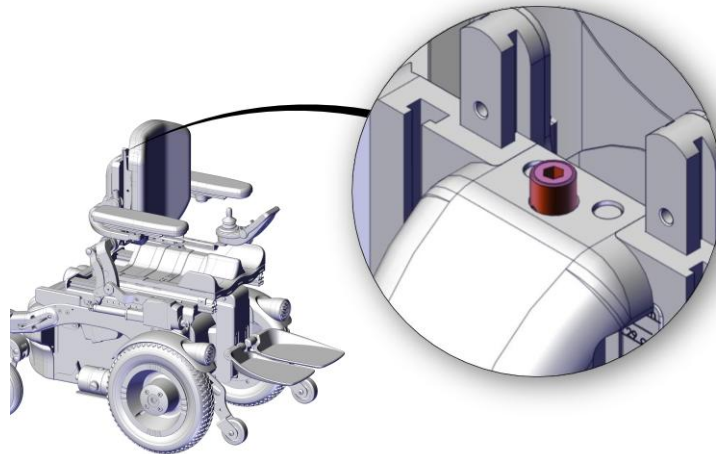

Figure 34

- Adjust the bolt shown in figure in order to adjust armrests height. Rotate it clockwise to rise the armrest and counterclockwise to lower it.
- When finished, tighten again the 4 screws previously loosen.

ALLEN WRENCH



5 mm

3.8 Vertical armrests angle - Version with biomechanical movements



RANGE

It is not easy to provide a range for this adjustment because there are too many configuration and possibilities.



Average needed time:

<5 min



Difficulty level:

Easy



RIGHT AND LEFT SIDE

It is possible to adjust separately left and right side.

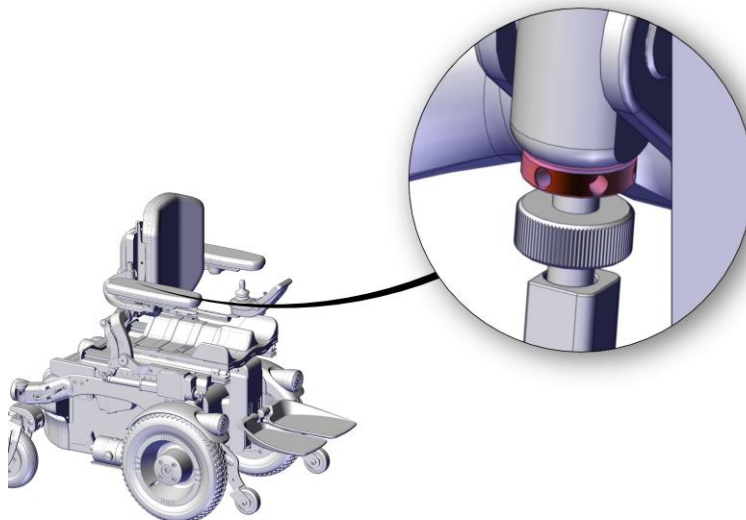

Figure 35

- Unscrew the nut shown in figure.

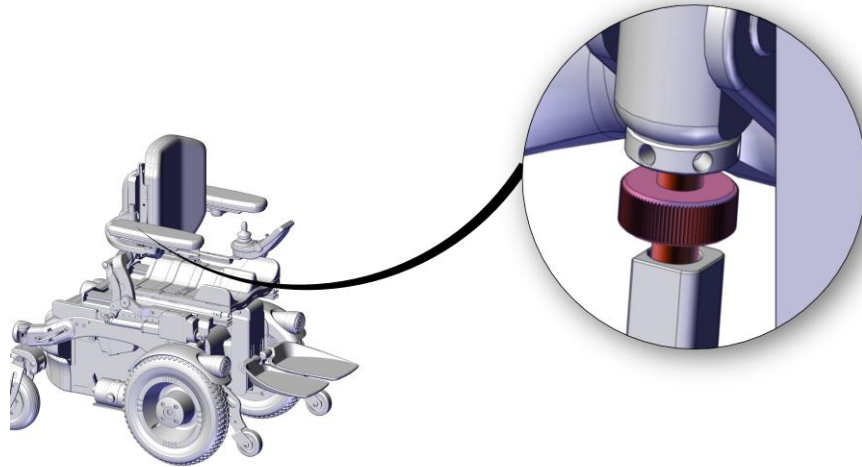
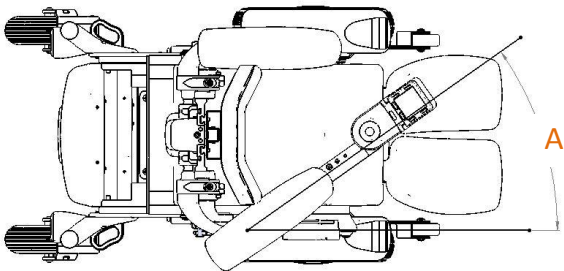





Figure 36

- Rotate the screw shown in figure clockwise to lower the armrest or rotate it counterclockwise to rise the armrest.

3.9 Horizontal armrests angle - Version with biomechanical movements

	(A) POSSIBLE VALUES
	12° 24° 36°

	Average needed time: <5 min		Difficulty level: Easy
---	---------------------------------------	--	----------------------------------

	RIGHT AND LEFT SIDE It is possible to adjust separately left and right side.
--	--

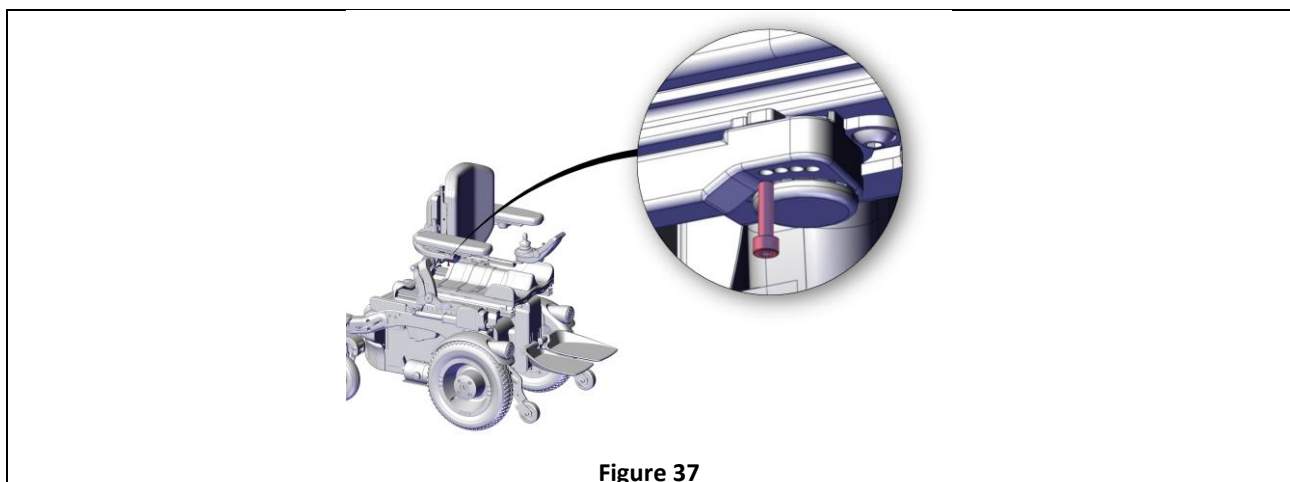

<ul style="list-style-type: none"> • Unscrew the screw shown in figure. • Set the armrest angle as desired. • Screw again the screw. 	ALLEN WRENCH 	4 mm
---	--	------

3.10 Footplates height - Version with biomechanical movements

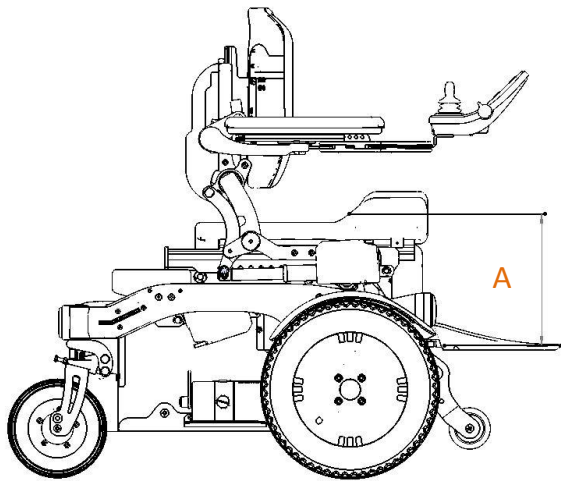
	LEGREST CONFIGURATION	(A) MIN VALUE	(A) MAX VALUE
	S042-V427	27.0 cm	30.0 cm
	S042-V428	30.0 cm	33.0 cm
	S042-V429	32.0 cm	40.0 cm
	S042-V430	35.0 cm	43.0 cm
	S042-V431	40.0 cm	48.0 cm



Average needed time:

5 min



Difficulty level:

Easy



RIGHT AND LEFT SIDE

It is possible to adjust separately left and right side.



WARNING

When adjusted the footplates height, it is necessary to update the right value of parameter PG6 (legrest length) in the software of the wheelchair. For more information see section 3.2.

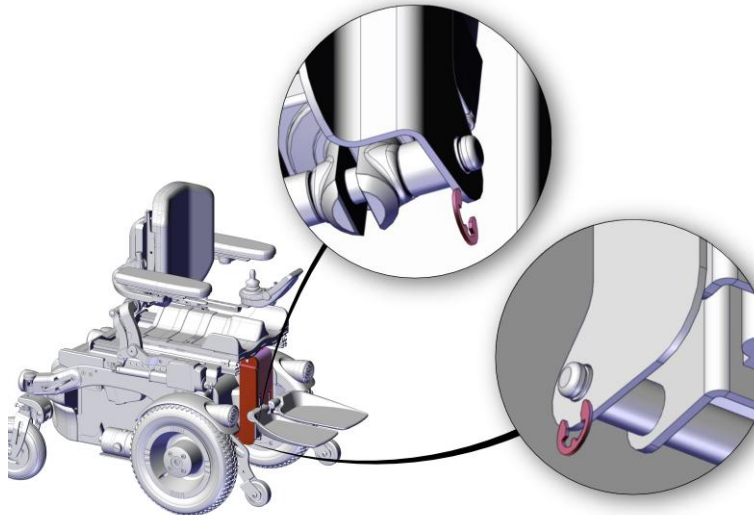

Figure 38

- Remove the 2 Seegers shown in figure. Use a screwdriver as a lever.
- Remove the cover.

SCREWDRIVER

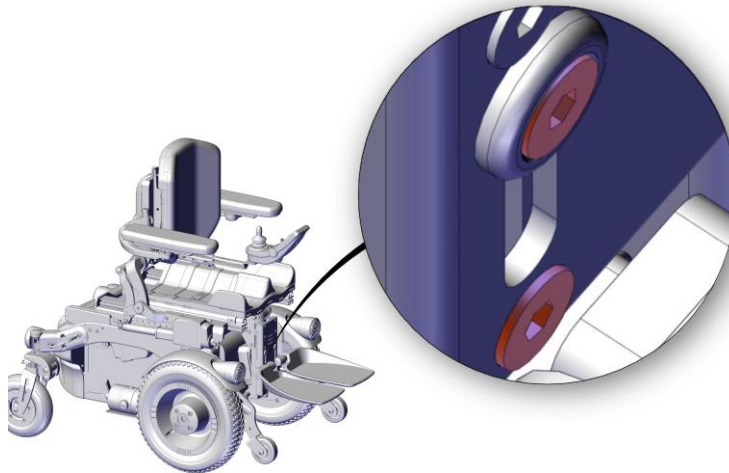

Figure 39

- Loosen the 2 screws shown in figure.
- Adjust the height as desired.
- Tighten again the screws.
- Mount again the cover.

ALLEN WRENCH



4 mm

3.11 Backrest height - Version with biomechanical movements



	CONFIGURATION	(A) POSSIBLE VALUES
		M1 P2 – S042-V378 M2 P1 – S042-V379 M1 P2 – S042-V387 M2 P1 – S042-V388
M2 P2 – S042-V380 M2 P2 – S042-V389		45.0 cm 49.0 cm 53.0 cm 57.0 cm
M3 P1 – S042-V381 M4 P2 – S042-V384 M3 P1 – S042-V390 M4 P2 – S042-V393		51.0 cm 55.0 cm 59.0 cm 63.0 cm
M3 P2 - S042-V382 M4 P3 – S042-V385 M3 P2 - S042-V391 M4 P3 – S042-V394		54.0 cm 58.0 cm 62.0 cm 66.0 cm
M4 P1 – S042-V383 M4 P1 – S042-V392		51.0 cm 55.0 cm 59.0 cm 63.0 cm

Table 17

	<p>Average needed time:</p> <p>20 min</p>		<p>Difficulty level:</p> <p>Easy</p>
---	--	--	---

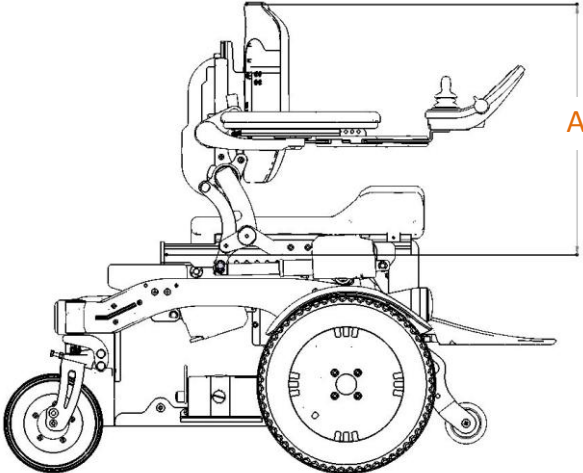
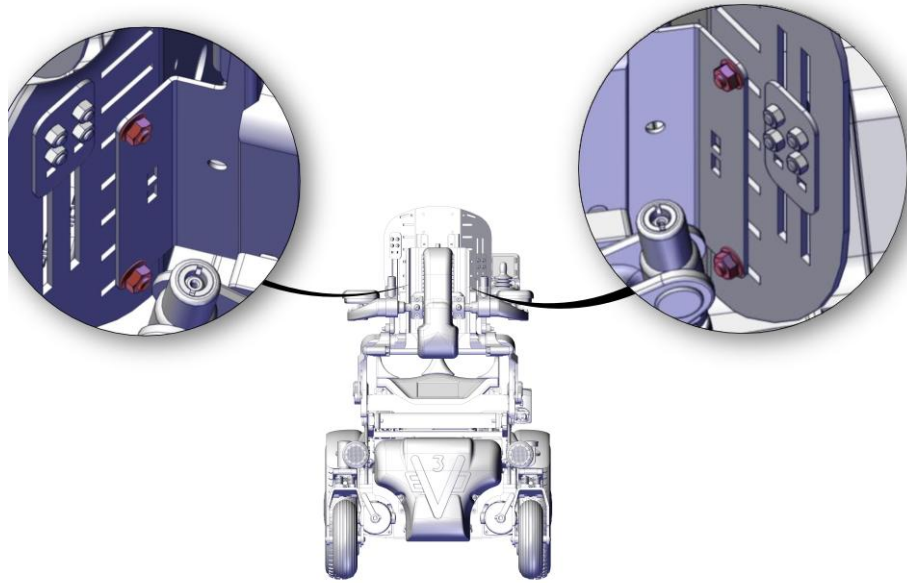

Figure 40

- Remove the backrest upholstery.
- Unscrew the 4 screws shown in figure.
- Adjust the height as desired.
- Screw again the screws.
- Mount again the backrest upholstery.

OPEN-END WRENCH

8 mm



3.12 Joystick position - Version with biomechanical movements



RANGE

It is not easy to provide a range for this because there are too many configuration and possibilities.



Average needed time:

<5 min



Difficulty level:

Easy

3.12.1 Standard support - Depth



Figure 41

- Unscrew the 2 screws shown in figure.
- Adjust the depth of the joystick as desired.
- Screw again the screws.

ALLEN WRENCH



5 mm

ADJUNCTIVE ADJUSTMENT

Moreover it is possible to adjust the angle of the joystick simply acting on the two levers shown in figure.



Figure 42

3.12.2 Retractable support S045-V263 - Depth



Figure 43

- Unscrew the 2 screws shown in figure.
- Adjust the depth and the height of the joystick as desired.
- Screw again the screws.

ALLEN WRENCH



5 mm

3.13 Seat depth- Version without biomechanical movements

	WHEELCHAIR SIZE	(A) MIN VALUE	(A) MAX VALUE
	M1 - S042-V073	300 mm	420 mm
	M2 - S042-V074	300 mm	460 mm
	M3 - S042-V075	300 mm	485 mm
		485 mm	500 mm
	M4 - S042-V071	30.0 mm	485 mcm
		485 mm	520 mm

Table 18



WARNING

It is needed to set separately left and right seat depth. Always set them at the same manner.

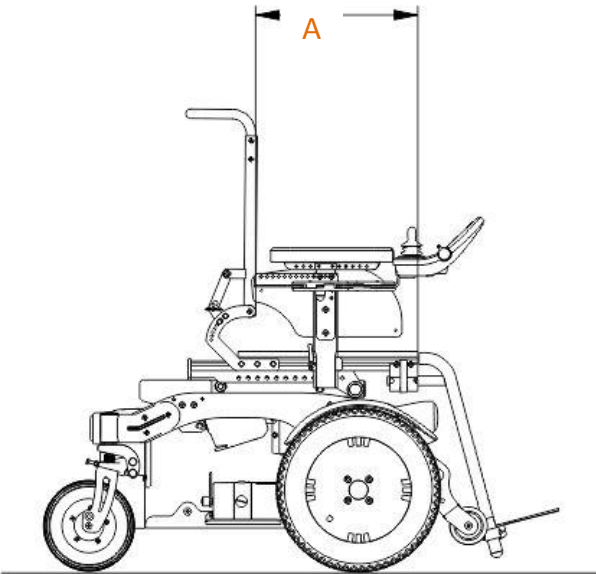

Average needed time:

5 min



Difficulty level:

Easy

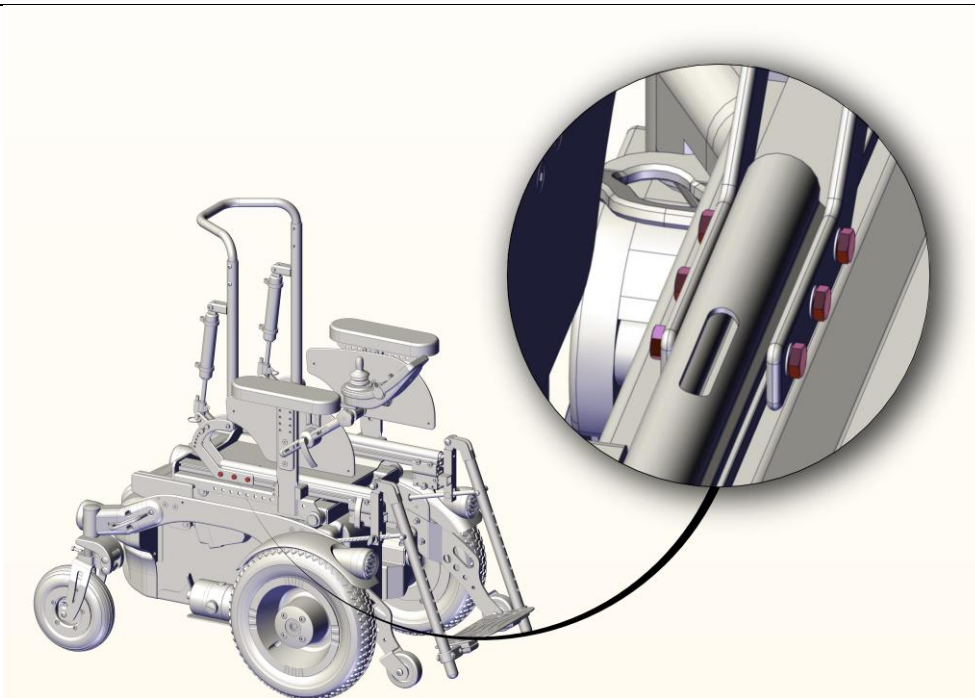

Figure 44

- Remove the backrest.
- Loosen the 6 screws shown in figure.
- Set the backrest according to the desired seat depth.
- Tight again the 6 screws.
- Mount again the backrest.

OPEN-END WRENCH



10 mm

3.14 Backrest angle- Version without biomechanical movements

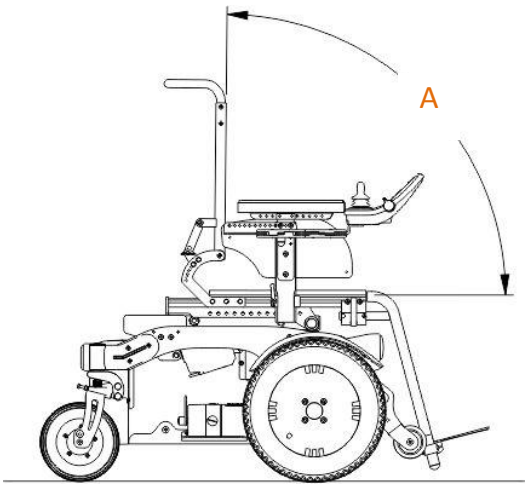
	BACKREST CONFIGURATION	(A) POSSIBLE VALUES
	Angle adjustable with fixed position	90° or 95° 95° or 100° 100° or 105° 105° or 110° 110° or 115° 115° or 120°
	Angle adjustable with pistons	See section 3.14.1



WARNING

It is needed to set separately left and right backrest angle. Always set two parts of backrest at the same manner.



Average needed time:
5 min



Difficulty level:
Easy

Angle adjustable with pistons

Use the lever located on the push bar to move the backrest.

Angle adjustable with fixed position

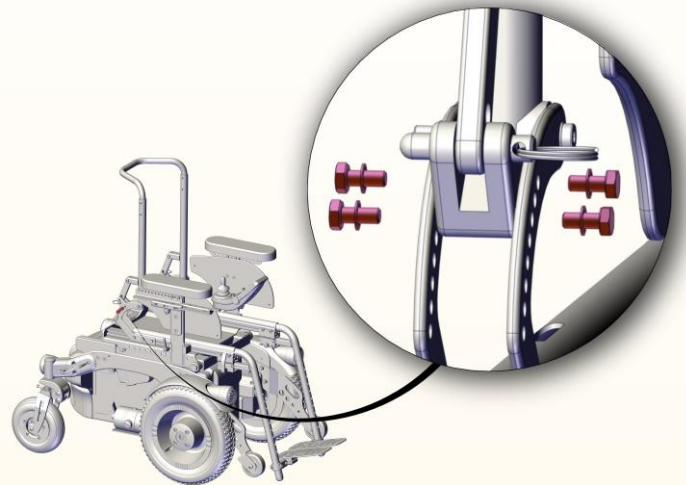

Figure 45

- Unscrew the 4 screws shown in figure.
- Set the position of the hardware highlighted in figure according to the desired backrest angle.
- Screw again screws.

OPEN-END WRENCH



10 mm

ADDITIONAL ADJUSTMENT

After adjusted the angle of backrest as described above it is possible to adjust of more 5° simply acting on the axis shown in figure.

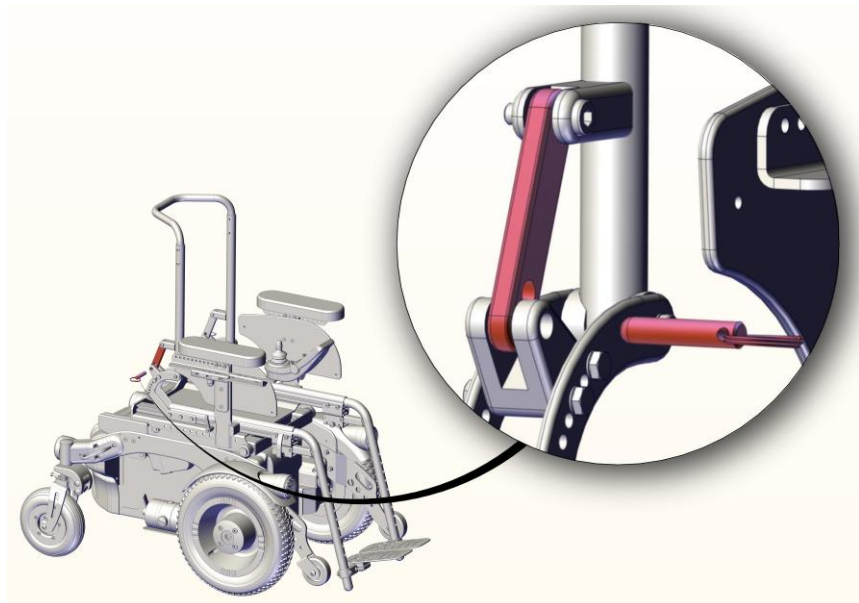

Figure 46

3.14.1 Adjunctive backrest angle adjustment



WARNING

This section refers only to angle adjustable backrest with pistons.



WARNING

It is needed to set separately left and right backrest angle. Always set two parts of backrest at the same manner.



Average needed time:

5 min



Difficulty level:

Easy

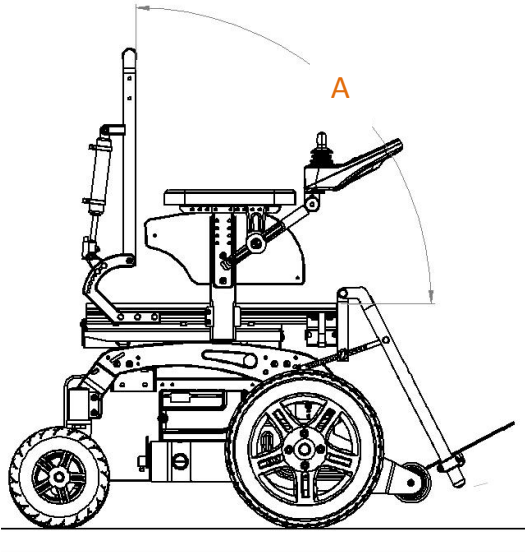
	BACKREST CONFIGURATION	(A) POSSIBLE VALUES
	<p>Angle adjustable with pistons</p>	<p>90° - 95° 95° : 100° 100° : 105° 105° : 110° 110° - 115° 120° - 125°</p>

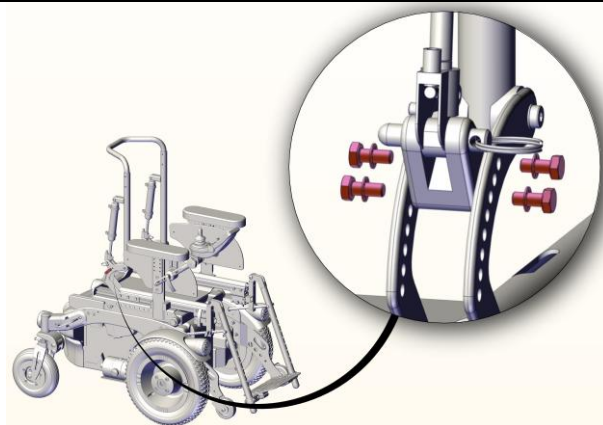

Figure 47

- Unscrew the 4 screws shown in figure.
- Set the position of the hardware highlighted in figure according to the desired backrest angle.
- Screw again screws.

OPEN-END WRENCH



10 mm

3.15 Armrests depth- Version without biomechanical movements



RANGE

It is not easy to provide a range for adjustment of armrests depth because there are too many configuration and possibilities.



RIGHT AND LEFT SIDE

It is possible to adjust separately left and right armrest.



Average needed time:
5 min



Difficulty level:
Easy



RANGE

Please be sure that the chosen position doesn't represent an obstacle.



Figure 48

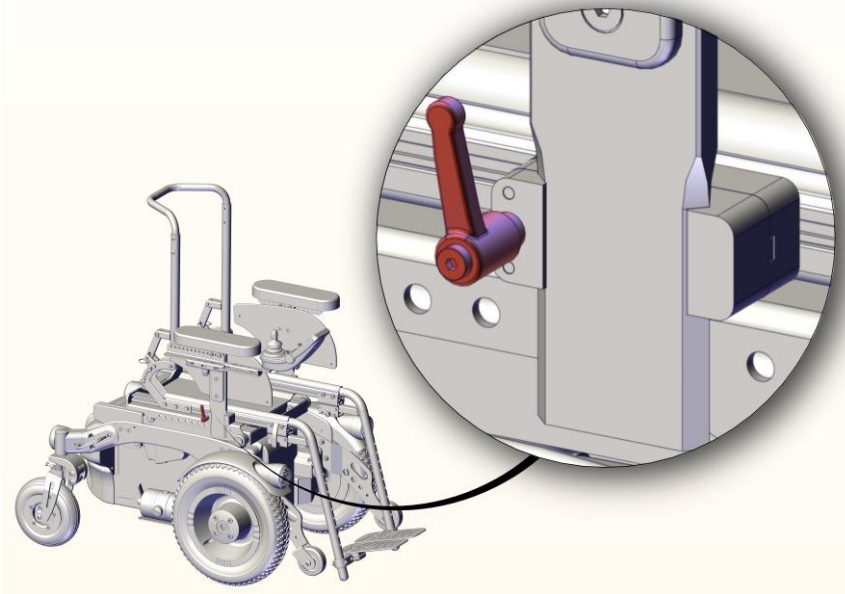

Figure 49

- Loosen the lever shown in figure and remove the armrest.

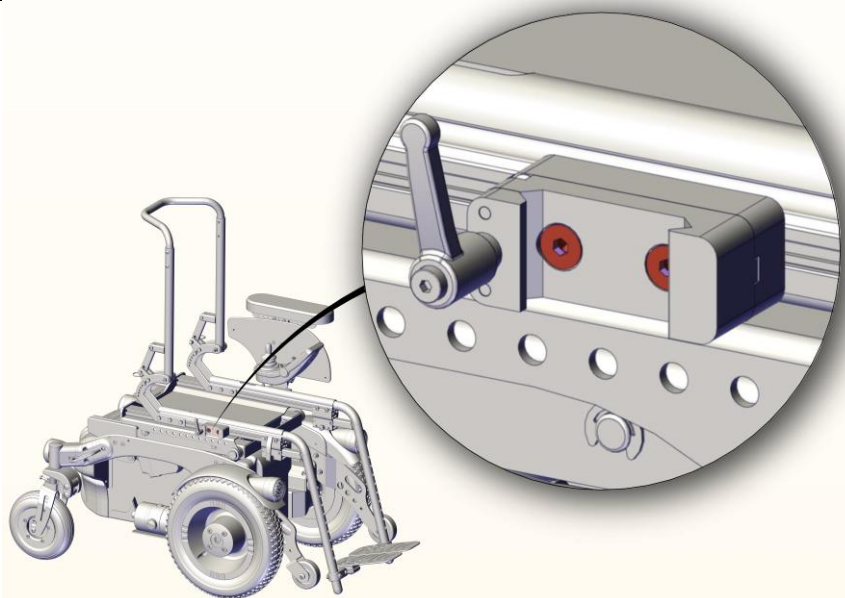

Figure 50

- Loosen the 2 screws shown in figure and set the depth of armrest clamp as desired.
- Tighten again the 2 screws and put back the armrest.

ALLEN WRENCH



4 mm

ADDITIONA ADJUSTMENT

Moreover it is possible to adjust armrest depth unscrewing the 2 screws shown in figure with a 4 mm allen wrench.



Figure 51

3.16 Armrests height- Version without biomechanical movements

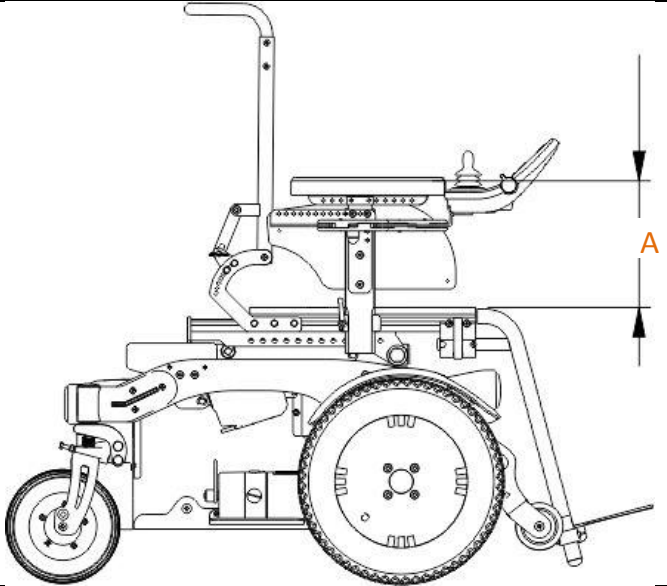
	(A) MIN VALUE	(A) MAX VALUE
	230 mm	300 mm



RIGHT AND LEFT SIDE

It is possible to adjust separately left and right armrest.



**Average needed
time:**
<5 min



Difficulty level:
Easy



SIDEPAD, JOYSTICK AND ARMREST HEIGHT

It is better to adjust first armrest height, then joystick and finally the sidepad.

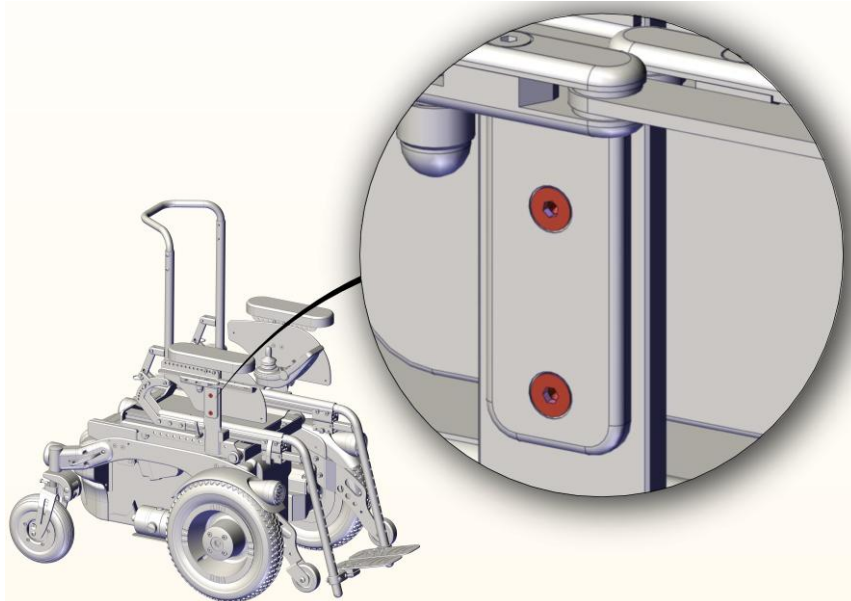

Figure 52

- Loosen the 2 screws shown in figure.
- Set the armrest according to the desired height.
- Tight again the 2 screws.

ALLEN WRENCH



4 mm

3.17 Sidepad height- Version without biomechanical movements



RANGE

It is not easy to provide a range for adjustment of sidepad because there are too many configuration and possibilities.



RIGHT AND LEFT SIDE

It is possible to adjust separately left and right sidepad.



SIDEPAD, JOYSTICK AND ARMREST HEIGHT

It is better to adjust first armrest height, then joystick and finally the sidepad.



Average needed time:

<5 min



Difficulty level:

Easy

RANGE

Please be sure that the chosen position doesn't represent an obstacle for armrest.



Figure 53

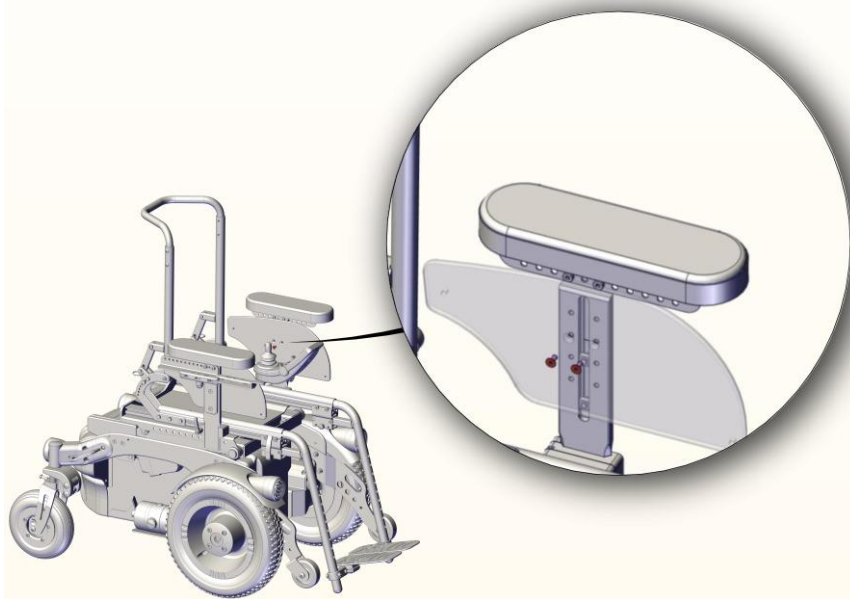

Figure 54

- Unscrew the 2 screws shown in figure and set the position of sidepad as desired.
- Screw again the 2 screws.

ALLEN WRENCH



3 mm

3.18 Footplates height- Version without biomechanical movements

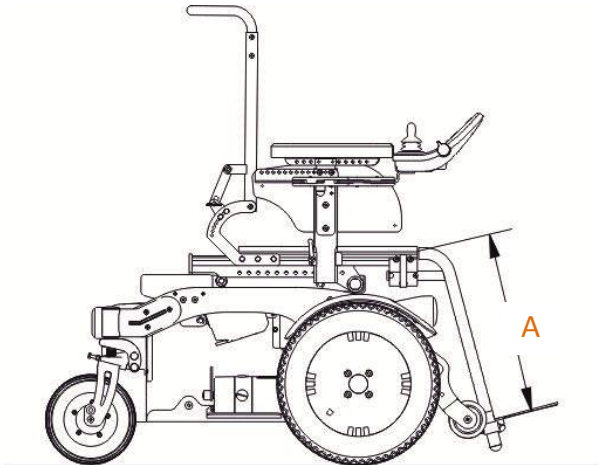
	LEGREST CONFIGURATION	(A) POSSIBLE VALUES
	Fixed angle	15.0 cm 17.5 cm 20.0 cm 22.5 cm 25.0 cm 27.5 cm 30.0 cm 32.5 cm 35.0 cm 37.5 cm 40.0 cm
Angle adjustable	15.0 cm 17.5 cm 20.0 cm 22.5 cm 25.0 cm 27.5 cm 30.0 cm 32.5 cm 35.0 cm 37.5 cm	



RIGHT AND LEFT SIDE

It is possible to adjust separately left and right legrest if you have splitted footrest.



Average needed time:
<5 min



Difficulty level:
Easy

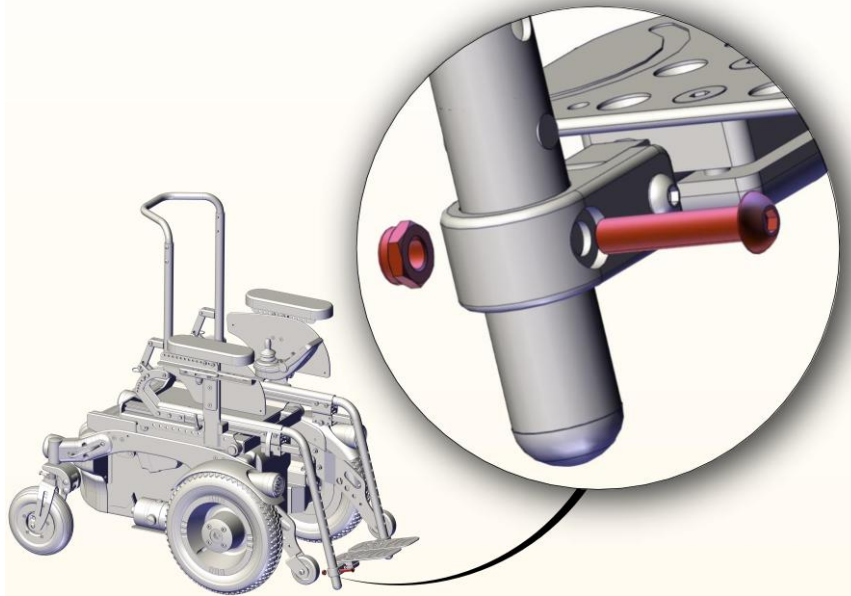

Figure 55

- Unscrew the screw shown in figure with the 6 mm allen wrench while holding the nut behind with the 13 mm open-end wrench.
- Repeat the operation for both left and right side of the wheelchair.
- Set the position of the footplate according to desired height.
- Screw again the screws.

ALLEN WRENCH



6 mm

OPEN-END WRENCH



13 mm

3.19 Footplates depth and angle- Version without biomechanical movements



RANGE

It is not easy to provide a range for adjustment of footrests because there are too many configuration and possibilities. In any case it is always possible to choose between 3 different depth.



RIGHT AND LEFT SIDE

It is possible to adjust separately left and right legrest if you have splitted footrest.



Average needed time:

<5 min



Difficulty level:

Easy

Angle adjustment

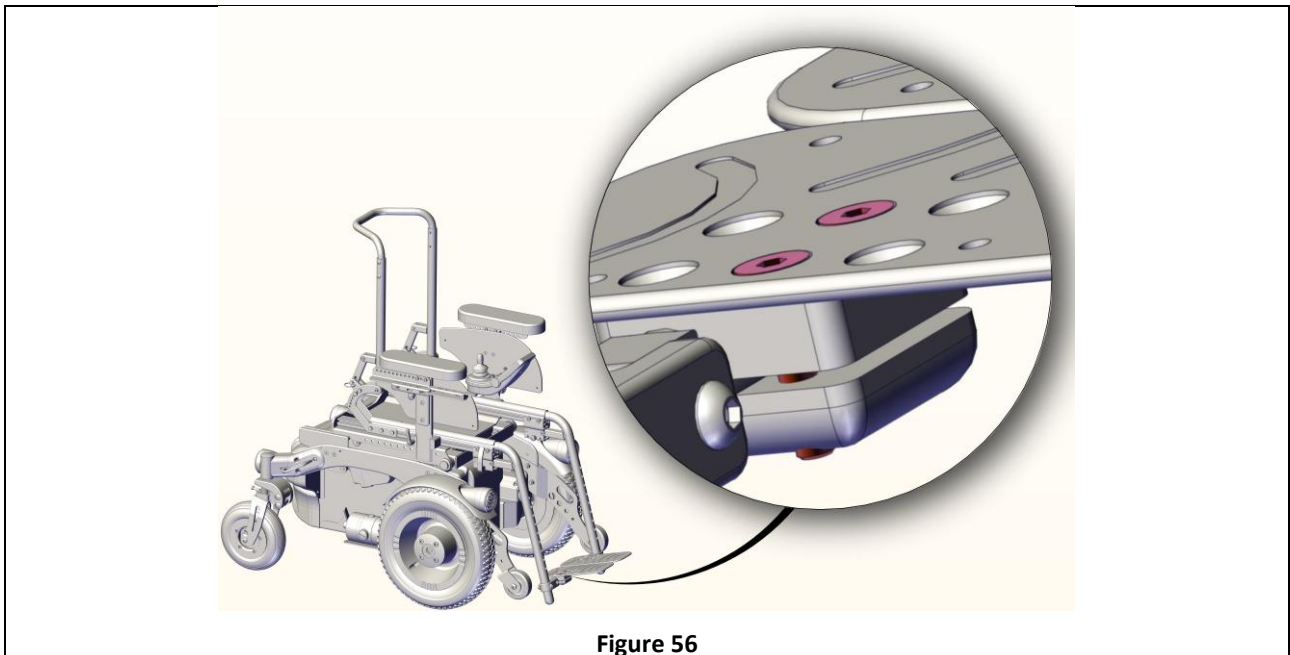

Figure 56

- Loosen the 2 screws shown in figure.
- Set the position of the footplate according to desired angle.
Tighten again the screws.
- Tighten again the screws.

ALLEN WRENCH



4 mm

Depth adjustment

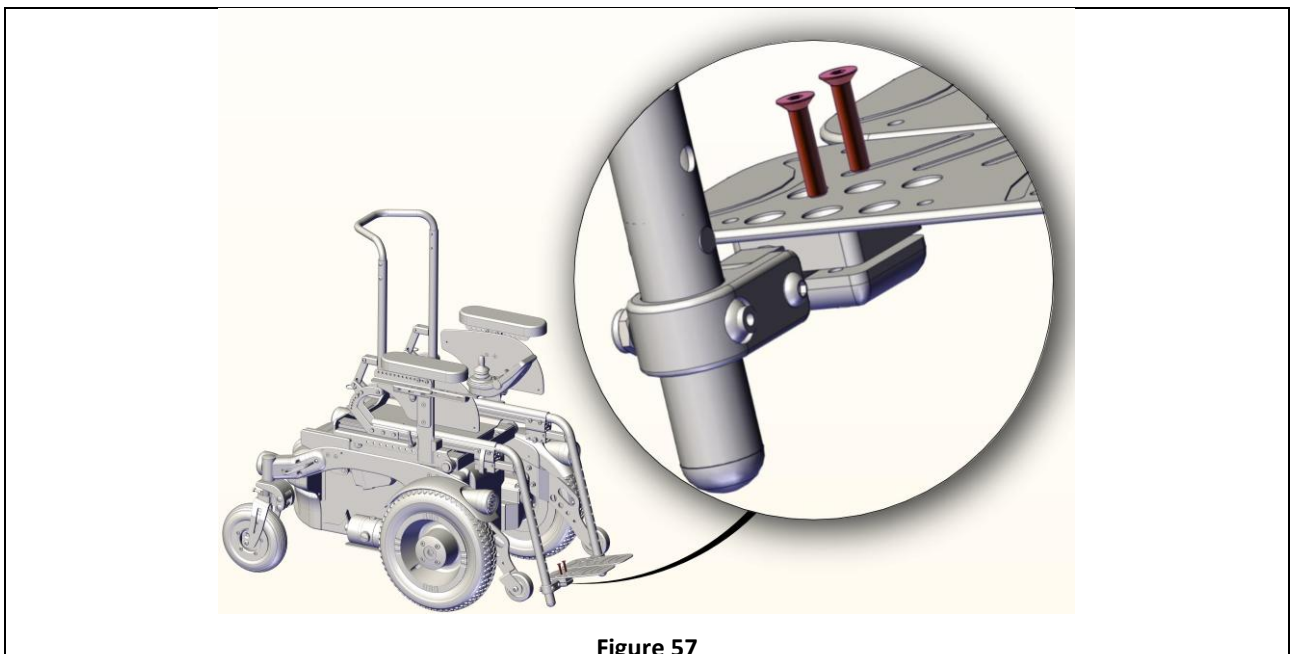

Figure 57

- Unscrew the 2 screws shown in figure.
- Set the position of the footplate according to desired depth.
- Screw again the screws. Screw again the 2 screws.

ALLEN WRENCH



4 mm

3.20 Joystick position- Version without biomechanical movements



RANGE

It is not easy to provide a range for this because there are too many configuration and possibilities.



Average needed time:

<5 min



Difficulty level:

Easy

3.20.1 Standard support - Depth and height

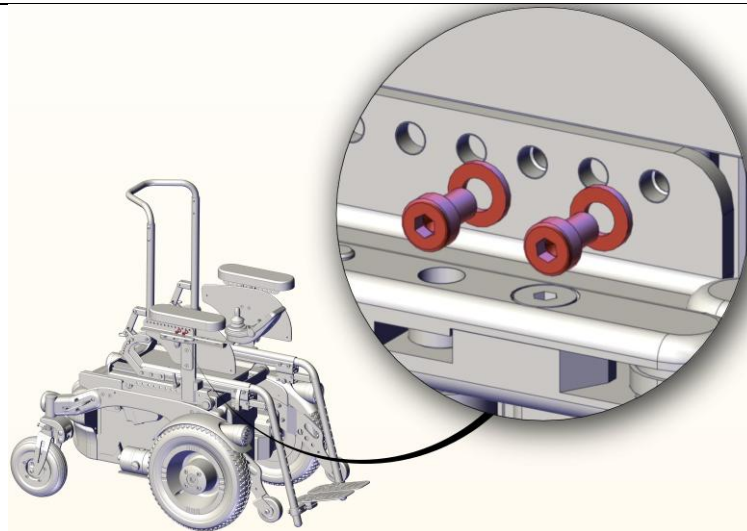

Figure 58

- Unscrew the 2 screws shown in figure.
- Adjust the depth and the height of the joystick as desired.
- Screw again the screws.

ALLEN WRENCH



4 mm

ADJUNCTIVE ADJUSTMENT

Moreover it is possible to adjust the angle of the joystick simply acting on the two levers shown in figure.

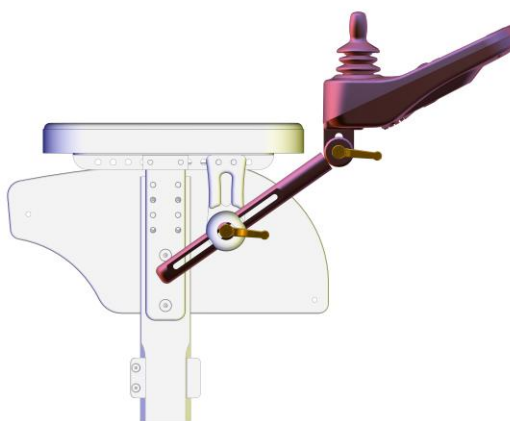

Figure 59

3.20.1 Retractable support - Depth and height

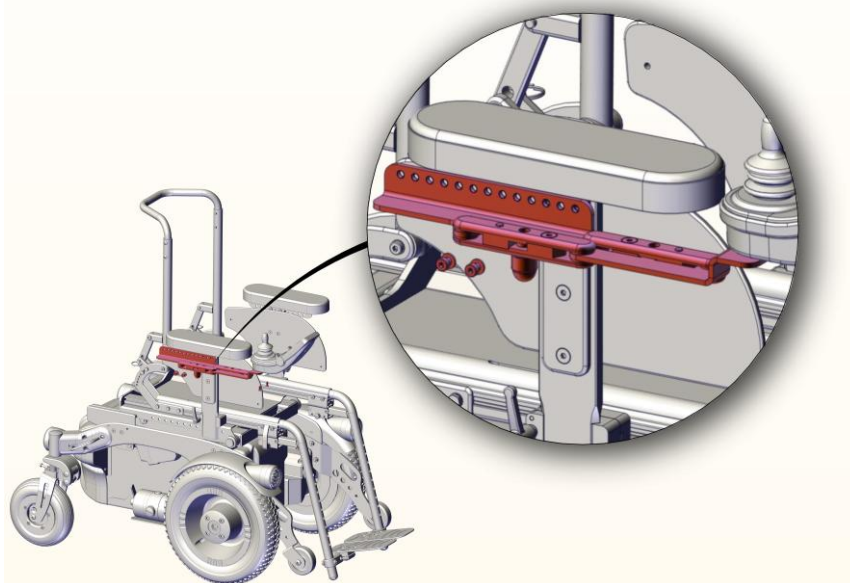

Figure 60

- Unscrew the 2 screws shown in figure.
- Adjust the depth and the height of the joystick as desired.
- Screw again the screws.

ALLEN WRENCH



4 mm

3.21 Default position

Default position means that all adjustable parts of the wheelchair are set in the most stable and safe configuration

ADJUSTABLE PARTS	VALUE	NOTES
Seat angle	0°	
Backrest angle	90°	
Legrest angle	90°	Or minimum
Seat height	0 cm	

Table 19

4 USE OF THE PRODUCT



WARNING

Do not operate the wheelchair if it is behaving abnormally or erratically.
The wheelchair may come to a sudden stop at any time during operation.



WARNING

Do not stand on the product. Always use caution when transferring in or out of the seat. Every precaution should be taken to reduce the transfer distance. Also be certain the wheel locks are engaged to prevent the wheels from moving.

Do not let children use the wheelchair without supervision.



INFORMATION

The product is not intended to be dismantled. There are no parts of the product expected to be handled during normal use of it



INFORMATION

Do not install, maintain or operate the product without reading all warnings and this entire manual.

Always keep this manual in connection with the product.



INFORMATION

The wheelchair is designed for use mostly in indoor environments.



DRIVE WITH SEATING SYSTEM NOT IN DEFAULT POSITION

Seat tilt, backrest recline or legrest elevation may varies the center of gravity of the system wheelchair + user and increase tipping risk.
Always drive at low speed when the seating system is not in the standard position and use powered seating functions only on a flat horizontal surface.



WARNING

Do not carry passengers on the wheelchair independently of the age of the passenger. The wheelchair is not designed for weight training and is unsafe for use as a seat while weight training. Do not lean over the top of the back upholstery to reach objects from behind as this may cause the wheelchair to tip over. Do not shift your weight or sitting position toward the direction you are reaching as the wheelchair may tip over. Do not stand on the frame of the wheelchair.

Some pathologies may limit your ability to use your wheelchair safely. Be sure to consult with a doctor about your physical limitations.

Please practice your drive ability under the supervision of an assistant.

Dealing with uphill

When facing an uphill road it is recommended to set the seating system to default position. It is better to use a drive profile with low speed.

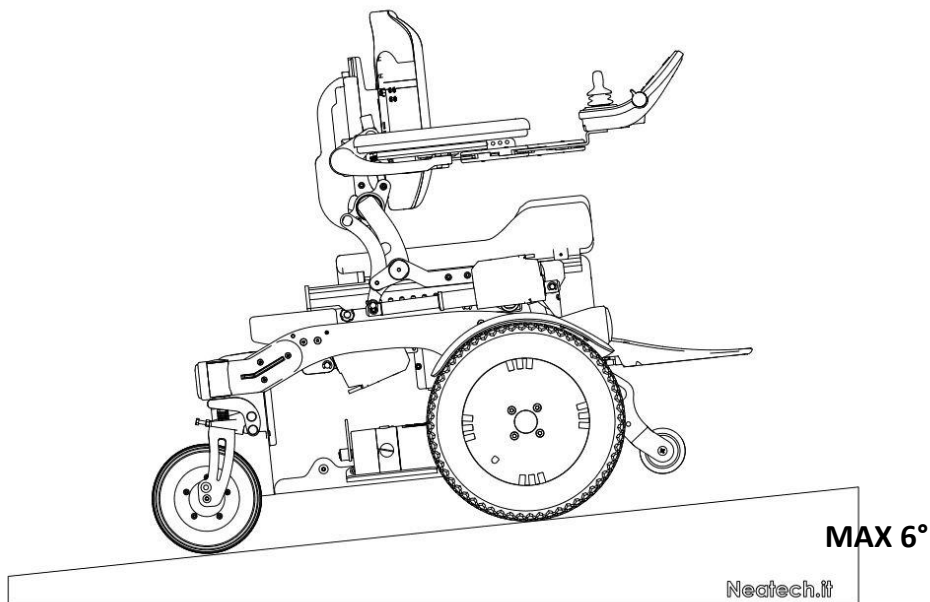

Figure 61

Dealing with downhill

When facing a downhill road it is recommended to set the seating system to default position. It is better to use a drive profile with low speed

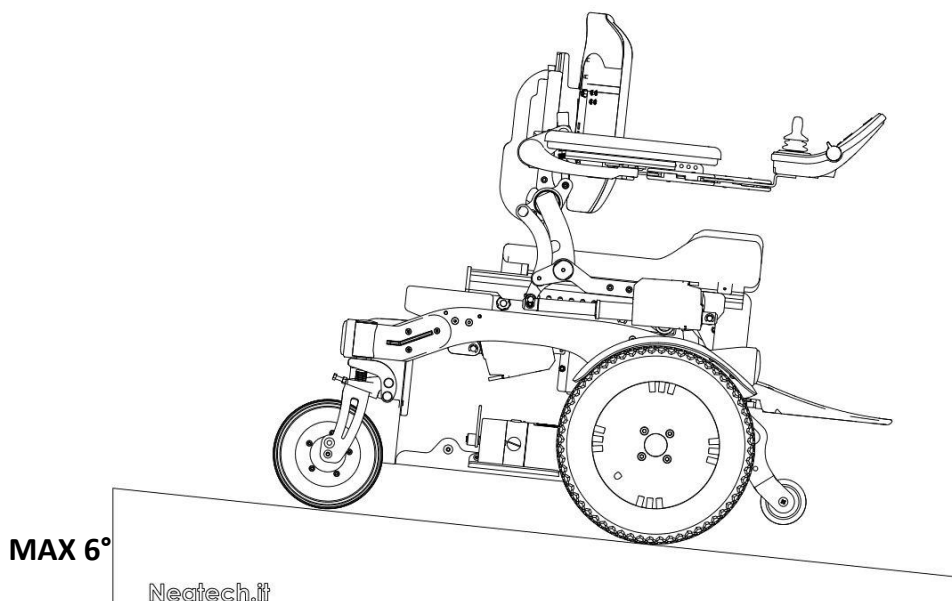

Figure 62



WARNING

Don't use the wheelchair up or down slopes with a gradient than indicated in specifications of this manual.

Don't use the wheelchair up or down ramps that are not equipped with proper edge protection to prevent the wheelchair from falling down.

Don't use the wheelchair down or up a hazardous incline if the surface is covered with snow, ice or the surface is uneven.



WARNING

The stopping distance on slopes can be significantly greater than on level ground

Dealing with side slopes

When facing with side slopes, always use the wheelchair with great caution and make sure the seating system is in the default position.

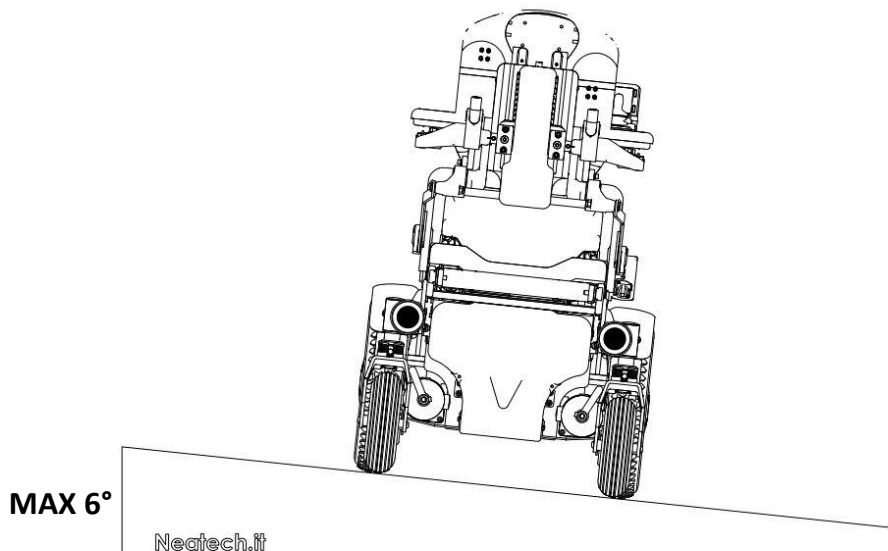

Figure 63

Turning with the wheelchair

When turning with the wheelchair, always use great caution.

Obstacle climbing

When facing with an obstacle, always use great caution and make sure the seating system is in the default position. The wheelchair is able to climb an obstacle of 50 mm with a run up of minimum 500 mm.

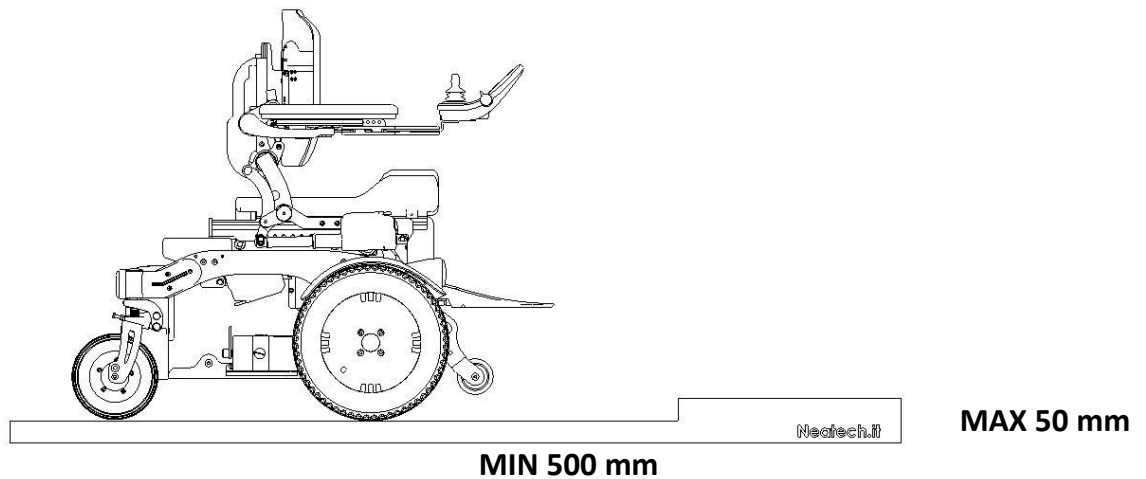

Figure 64

Driving in dark environments

Don't use the wheelchair in dark environments without lights turned on.

Pelvic belt

The wheelchair has the predisposition for a pelvic belt. **Pelvic belt is only design to position the user and not for any protection in case of accident.**

Transfer into and out the wheelchair

Users transfer is recommended with the presence of an assistant. Don't use footrests or armrests as support. Always turn off the wheelchair before transfer.

Lift of the wheelchair

Do not lift the wheelchair with a user on board. Do not lift the wheelchair grabbing the legrests. If you really need to lift the wheelchair, it is suggested to grab it with the help of at least one other people. Grab the wheelchair using the tie down shown in figure.

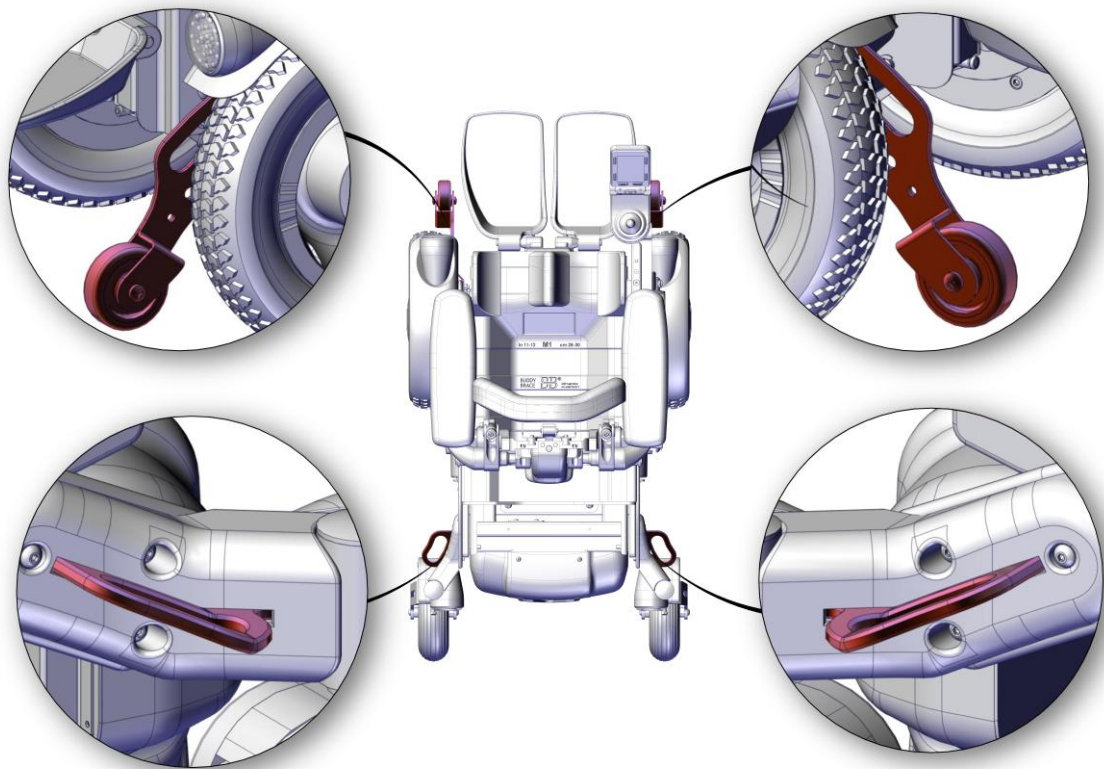

Figure 65

4.1 Rnet 80 A control system



Figure 66

FUNCTION	DESCRIPTION
On-Off	Use this function to turn on and off the wheelchair. Don't use this function to stop the wheelchair unless it is an emergency.
Horn	
MODE	Use this function to navigate all working mode of the wheelchair. For example it is possible to choose between drive and seat function.
PROFILE Speed increase/decrease	As default in the wheelchair they are saved some different drive profile for the use indoor and outdoor. Use the function PROFILE to change different types of profiles: they are sorted from the more indoor ones to the more outdoor ones. For each profile it is possible to change the speed.

Activate at the same time the functions to increase and decrease speed to enter a configuration menu.

FUNCTION	DESCRIPTION
Set time	Use this function to set the time shown on the display.
Distance	Use this function to see total and partial distance made with the wheelchair. It is also possible to reset partial distance.
Backlight	It is possible to adjust backlights of the screen.
Background	Use this function to choose the color of background of the display.

4.2 Manual brake release lever

In case of necessity it is possible to manually move the wheelchair.

First of all, you have to turn off the wheelchair.

Then you can act on the release lever shown in Figure.

When the brakes are released. it is not possible to drive the wheelchair.

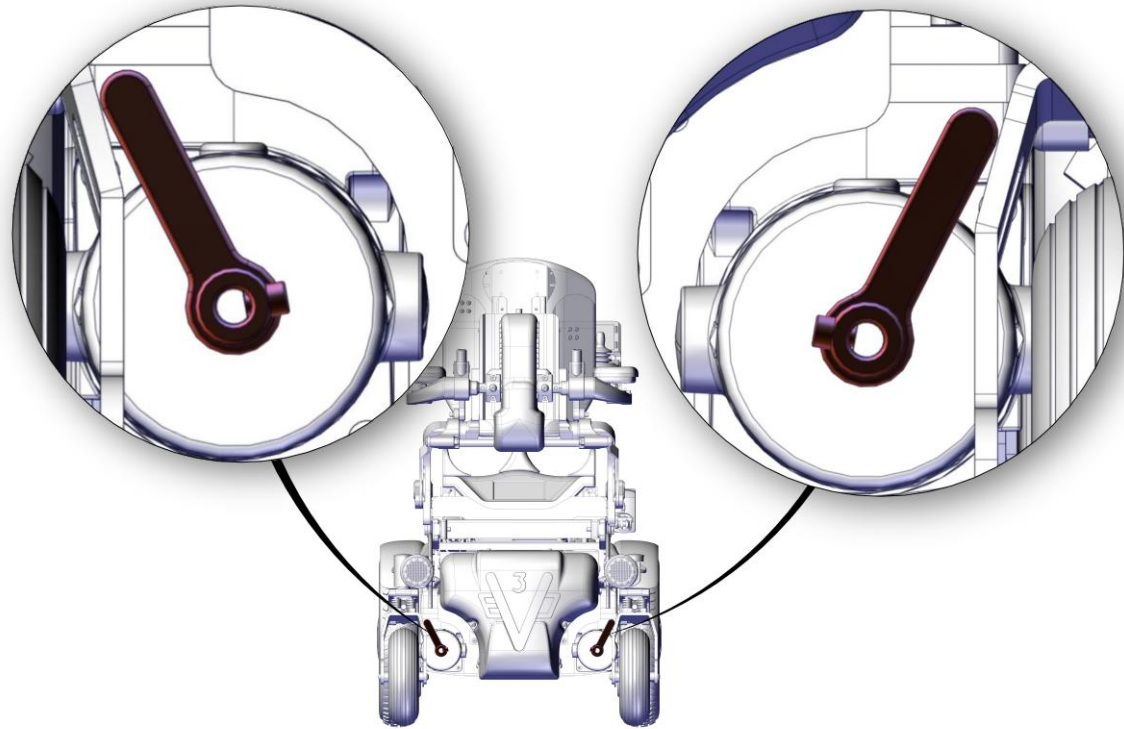

Figure 67



WARNING

When the brakes are released never use the wheelchair on a slope or a wet surface.

Don't operate the brake release without the presence of an assistant.



WARNING

The drive system should be re-engaged before an occupant is left unattended or attempts to operate the wheelchair.



WARNING

Always act on both left and right manual release levers.

4.3 Use as seat in a motor vehicle

The wheelchair is designed to be secured facing forward when used as a seat in a motor vehicle and it complies with the requirements of ISO 7176-19:2008.

It is possible to use four-point strap systems or the DAHL docking station.

Ease of access to, and maneuverability in, motor vehicle can be significantly affected by wheelchair size and turning radius. Smaller wheelchairs or with a shorter turning radius will generally provide greater ease of vehicle access and maneuverability to a forward-facing position.

Always use ISO 10542-1 approved Wheelchair Tiedown and Occupant Restraint Systems, which are suitable for the weight of the wheelchair or Dahl docking.

Wheelchair users should transfer to the vehicle seat and use the vehicle-manufacturer-installed restraint systems whenever it is feasible and the unoccupied wheelchair should be stored in a cargo area or secured in the vehicle during the travel.

For the correct positioning of occupant belt restraints on the user, please consider following.

- The pelvic belt should be worn low across the front of the pelvis, so that the angle of the pelvic belt is within the preferred zone of 30° to 75° to the horizontal, similar to that shown in figure.

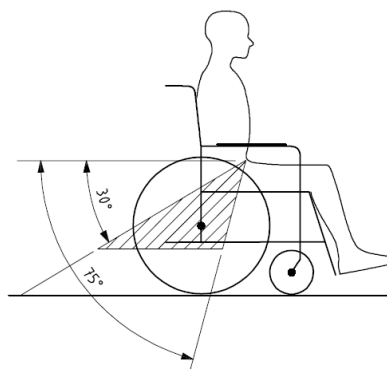

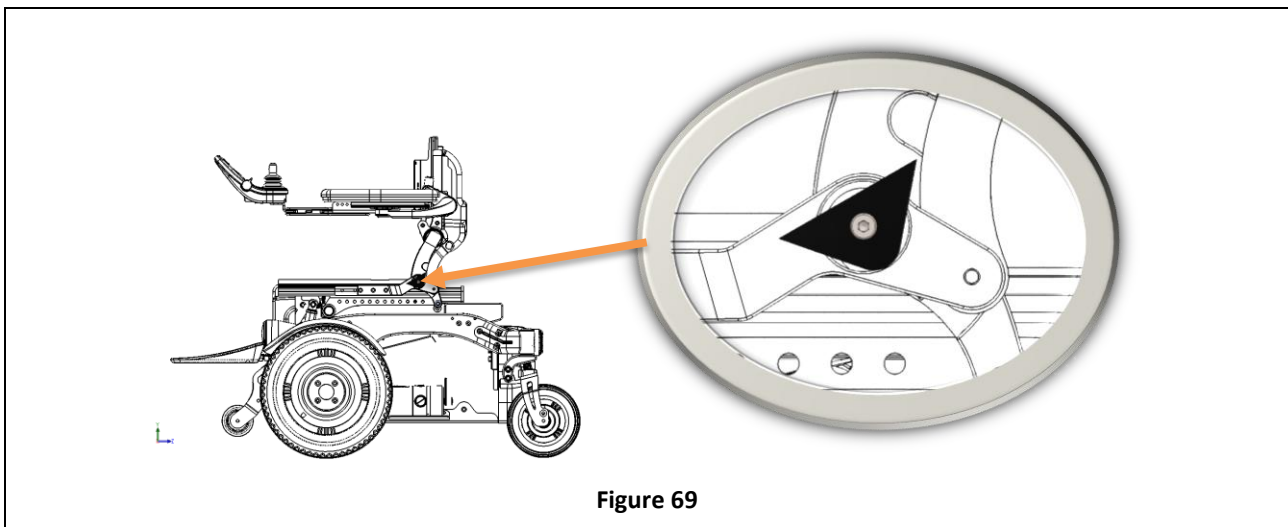



Figure 68

- Belt restraints should be adjusted as tightly as possible, consistent with user comfort.
- Belt should not be twisted during the use.

IMPROPER BELT RESTRAINT FIT	PROPER BELT RESTRAINT FIT
	
<p>BELT RESTRAINTS MUST NOT BE HELD AWAY FROM THE BODY BY WHEELCHAIR COMPONENTS SUCH AS ARMRESTS OR WHEELS</p>	<p>BELT RESTRAINTS SHOULD MAKE FULL CONTACT WITH THE SHOULDER, CHEST AND PELVIS AND PELVIC BELTS SHOULD BE POSITIONED LOW ON THE PELVIS NEAR THE THIGH ABDOMINAL JUNCTION</p>



<p>In order to mount pelvic belt on the wheelchair, firstly mount the fixing plate as shown in figure.</p> <p>Use socket head cap screw M6x10 and a 5 mm allen wrench.</p> <p>Repeat operation for both left and right side of the wheelchair.</p>	<p>ALLEN WRENCH</p>  <p>5 mm</p>
--	--

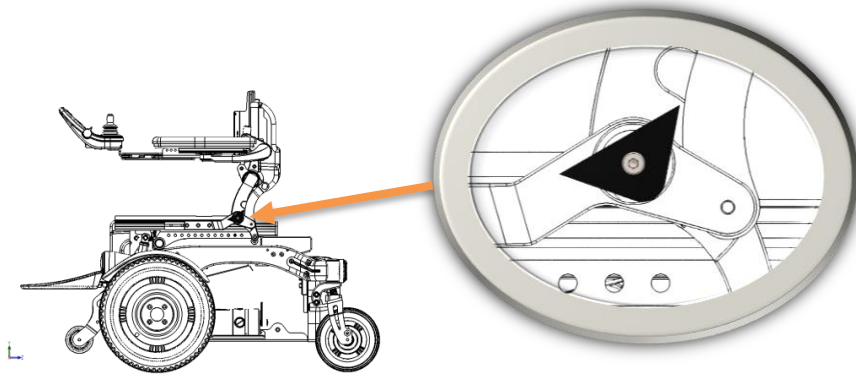

Figure 70

In order to mount chest belt on the wheelchair, firstly mount the fixing plate as shown in figure.

Use socket head cap screw M6x10 DIN 912 and a 5 mm allen wrench.

Repeat operation for both left and right side of the wheelchair.

ALLEN WRENCH



5 mm

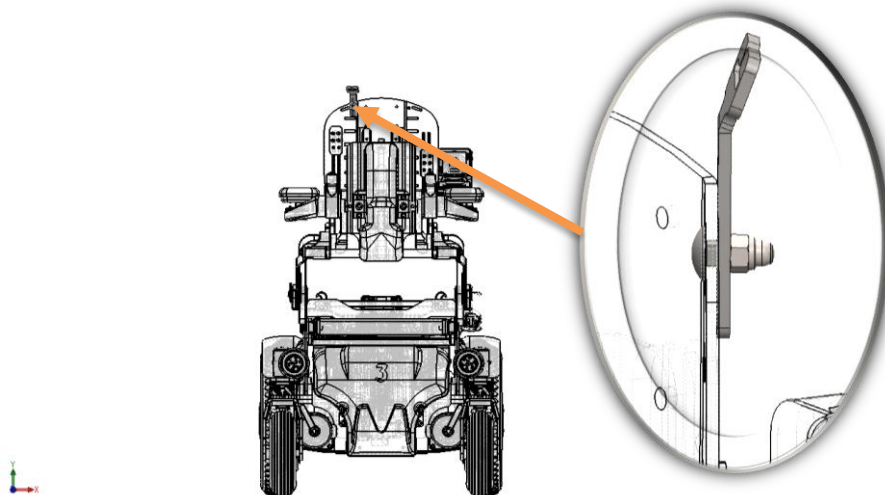

Figure 71

Moreover, chest belt must be fixed in the upper part of the backrest. Firstly mount the fixing plate as shown in figure.

Use hushroom head square neck bolt screw M5x16 DIN 603, M5 nut, and a 8 mm open-end wrench.

Repeat operation for both left and right side of the wheelchair.

OPEN-END
WRENCH



8 mm



WARNING

The seating system must be set in the DEFAULT POSITION when used in a motor vehicle. Particularly be sure that the seat is horizontal, legrest are completely down and backrest is completely up. For more information see section 3.21.



WARNING

Evo3 wheelchair has lots of configurations and accessories. The wheelchair safety when used as a seat in a motor vehicle is assured by the manufacturer if the specific configuration is mentioned in the order form and if all instructions in the manual are followed. Particularly it may exist some options or accessories that are not compatible with the use of the wheelchair as a seat in a motor vehicle, or it may exist some accessories that require some precautions.



WARNING

If the backrest is with gas springs, when using the wheelchair as a seat in a motor vehicle, it is necessary to lock the movement of the gas springs with the locking system shown in the picture. Always repeat the operation for the left and right side of the wheelchair. WARNING: Safety of wheelchair and user can't be assured when the movement of gas springs is not correctly locked while using the wheelchair as a seat in a motor vehicle.

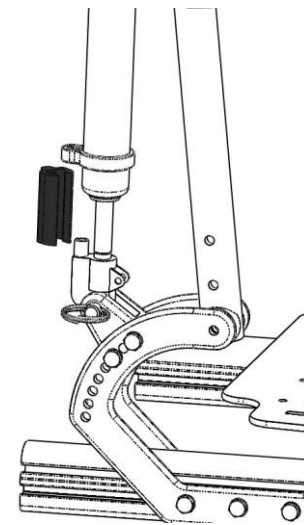

Figure 72



WARNING

The wheelchair complies with the requirements of ISO 7176-19:2008 and has been designed and tested for use only as a forward-facing seat in a motor vehicle.

Compliance with this standard does not preclude using the wheelchair facing rearward in large accessible vehicles such as autobus.



WARNING

The wheelchair has been dynamically tested in a forward facing orientation with the ATD restrained by both pelvic and shoulder belts.



WARNING

Both pelvic and shoulder belt should be used to reduce the possibility of head and chest impacts with vehicle components.



WARNING

In order to reduce the potential of injury to vehicle occupants wheelchair tray should be removed and secured separately in the vehicle.



WARNING

When possible other auxiliary wheelchair equipment should be either secured to the wheelchair or removed from the wheelchair and secured in the vehicle during travel, so that it does not break and cause injury to vehicle occupants in the event of a collision.



WARNING

You should not use this product in a motor vehicle if your weight is less than 22 kg.



WARNING

Postural supports should not be relied on for occupant restraint in a moving vehicle unless they are labelled as being in accordance with the requirements specified in ISO 7176-19:2008.



WARNING

The wheelchair should be inspected by a manufacturer's representative before reuse following involvement in any type of vehicle collision.



WARNING

Alterations or substitutions should not be made to the wheelchair securement points or to structural and frame parts or components without consulting the wheelchair manufacturer.



WARNING

Wheelchair has sealed type batteries. Never use different battery type when used in a motor vehicle.



WARNING

Care should be taken when applying the occupant restraint to position the seatbelt buckle so that the release button will not be contacted by wheelchair components during a crash.

4.3.1 Securing the wheelchair with Four points tie-down system

Use the tie down points marked with the symbol shown in figure.



Figure 73

Use the tie down points marked with the symbol shown in figure. Hook the wheelchair in 4 points: two in the front part and two in the rear part.

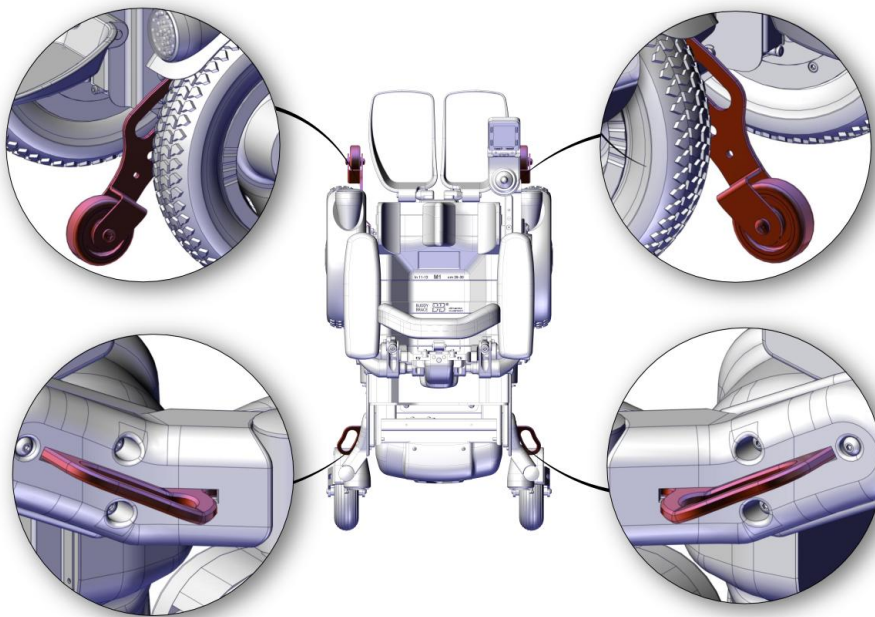

Figure 74

Use the tie down points Hook the wheelchair in 4 points: two in the front part and two in the rear part.

Tie down straps should form angles shown below.

PREFERRED ANGLES OF FRONT WHEELCHAIR TIE DOWN STRAPS

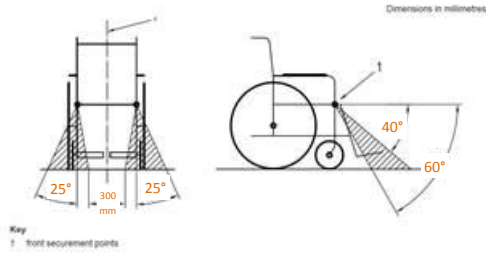

Figure 75

PREFERRED ANGLES OF REAR WHEELCHAIR TIE DOWN STRAPS

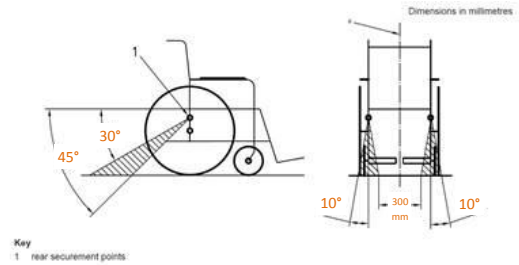

Figure 76



WARNING

Always use four tie down straps.

4.3.2 Dahl engineering docking station

WARNING

Please be sure that the vehicle is equipped with a fully working and compatible Dahl docking system.





Figure 77

- To use the system, maneuver the wheelchair slowly and in a uniform direction over the docking station. The lock plate under the wheelchair helps to guide the wheelchair into place in the docking station. When the lock plate is fully engaged in the docking station, a spring-action locking pin automatically secures the lock plate.
- The docking station is equipped with a control switch that indicates whether the lock plate is correctly secured in the docking station. As soon as the lock plate comes into contact with the locking pin, a warning tone will sound and the red led in the control panel will light up until the lock plate is either fully engaged or else the wheelchair is removed from the docking station. As an indication that the wheelchair is properly secured, the warning tone will cease, the red diode in the control panel will go out and the green led will light up.
- When the wheelchair is correctly secured, the safety belt should be fitted and adjusted so that it fits the user.
- **UNLOCKING PROCEDURE.** When the vehicle has been brought to a halt, remove the safety belt. To unlock commence by driving the wheelchair forward to release pressure on the lock pin and then press the red release button in the control panel. The locking pin will be triggered/released for approx 5 seconds, after which the locking pin is automatically locked/activated again. Do not attempt to reverse out the docking station until the red LED on the control module, which indicates the unlock position, has been illuminated. Move the wheelchair away from the docking station within this 5-second period.



WARNING

Attempting to reverse the wheelchair before the red LED has been illuminated will result in blocking the docking station lock mechanism which makes it impossible to reverse. If this happens repeat above unlocking procedure.

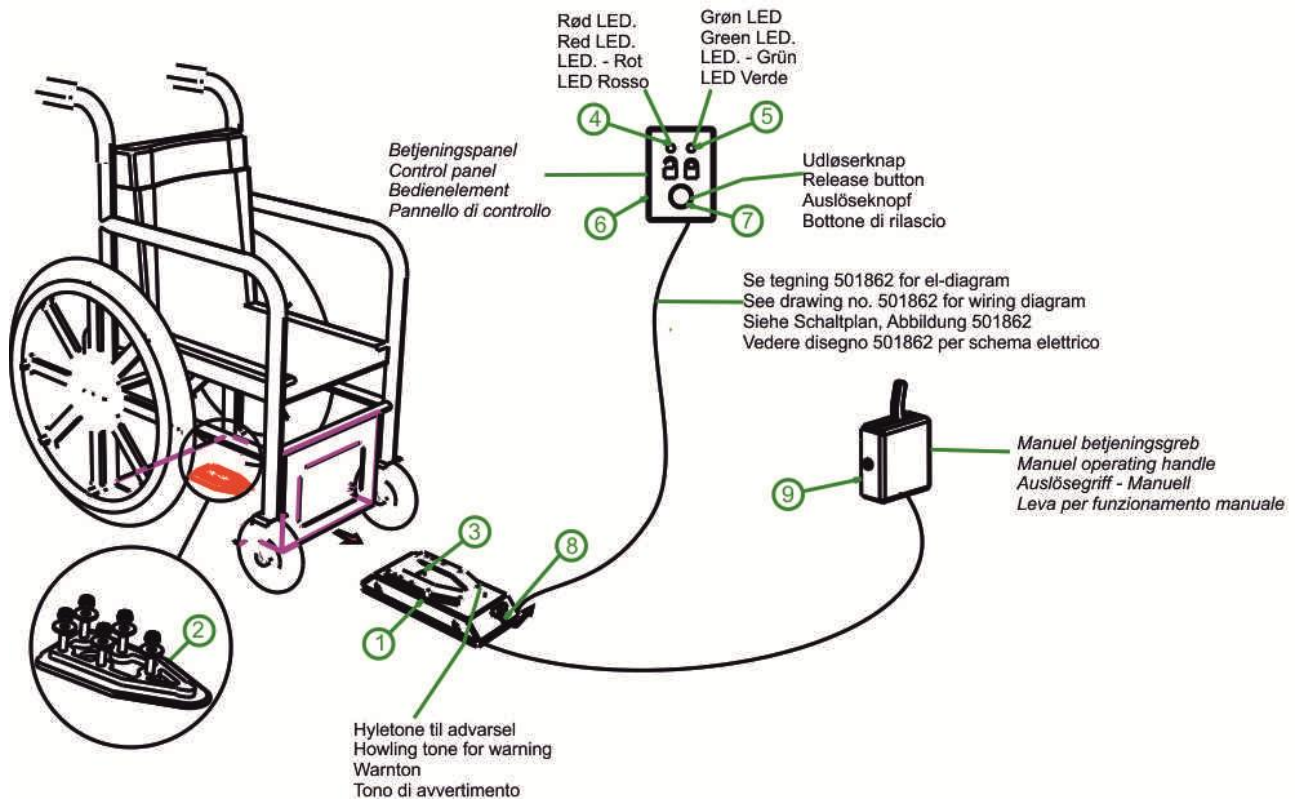

Figure 78



CONTACT INFORMATION

For more information contact the manufacturer of the wheelchair or the manufacturer of the docking station.

Dahl Engineering

Løvevej 3

DK-7700 Thisted

Tel. +45 96 18 00 77

<https://dahleengineering.dk>

sales@dahleengineering.dk

4.3.3 Mounting of the Dahl engineering docking station - Installation of Dahl Lock plate assembly under the wheelchair

Please also refer to the Maintenance Manual User Guide for the Dahl Docking Station and vehicle specific installation instructions from Dahl Engineering. Instruction must be complied with.

Installation of the Dahl Docking station must be carried out by a registered car adaptation company by a qualified and experienced technician/fitter.

CONTACT INFORMATION	
	For ordering the Dahl Docking station and components needed for the installation in the vehicle and other accessories, please contact the manufacturer of the docking station.
	Dahl Engineering
	Løvevej 3
	DK-7700 Thisted
	Tel. +45 96 18 00 77
	https://dahleengineering.dk
	sales@dahleengineering.dk

Kit Dahl

 <p style="text-align: center;">Figure 79</p>	ID	Quantity
	(1) #500673	1
	(2) #500561	1
	(3) #502800	5
	(4) #502210	5

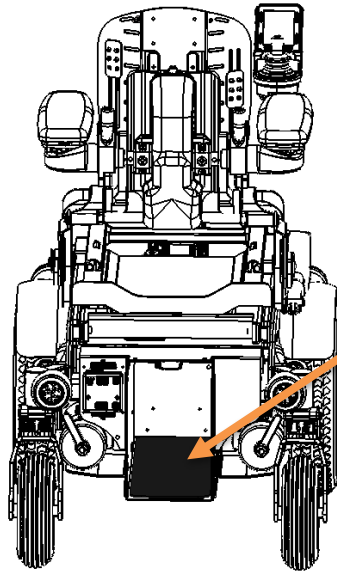

Figure 80

- Remove batteries. For more information see section 4.7.1 .
- Remove the plate shown in figure.

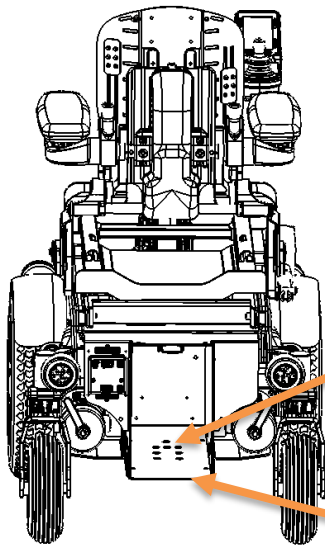
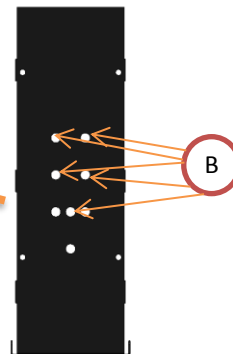
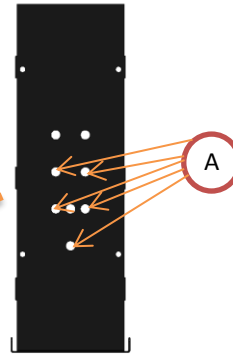

Figure 81



- In the bottom of battery box there are globally 8 holes. 5 of them must be used to mount the nuts of Dahl kit #502210. Choose one of two possibilities shown in figure (A or B).

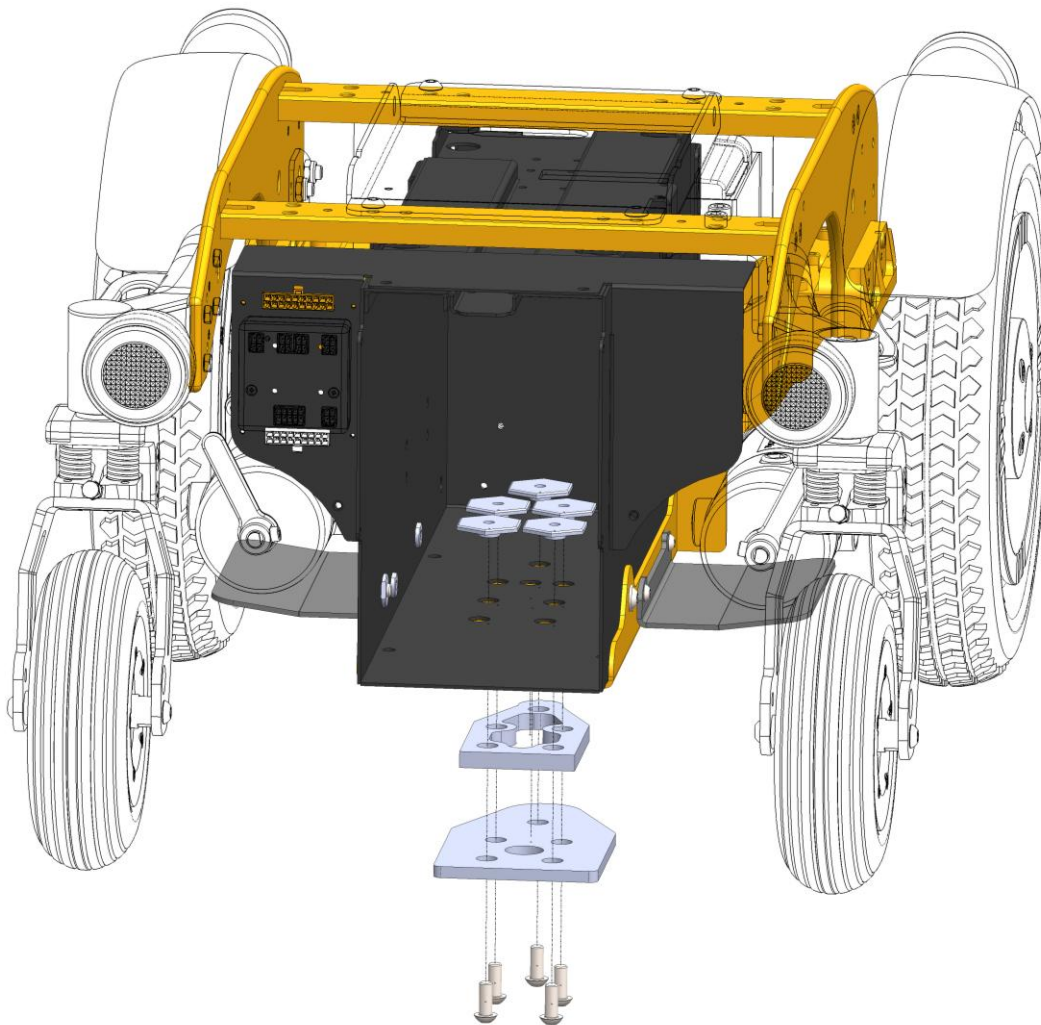

Figure 82

- Place nuts provided into the DAHL kit #502210 in the 5 chosen holes with recess down.
- Lock plate (A) and spacer (B) as shown in figure.

WARNING



When mounting the bolts of DAHL kit, you must assure that tightening torque is in the range 16-18 Nm.

Use Loctite 222® to secure thread on screws to prevent them from coming loose.

Only original DAHL #502800 bolts with strength 14.9 must be used, as normal bolts will not be strong enough.

If necessary cut the screws not to interfere with the battery.

LOCTITE® is a registered mark of Henkel AG & Company KGaA.

- Mount again the plate previously removed. The purpose of this plate is to offer a larger support surface and to avoid that batteries rest only on nuts of Dahl kit just mounted. It could be needed to cut this plate in order to let room for the Dahl kit just mounted.
- Mount again batteries. For more information see section 4.7.1 .



Figure 83

4.4 Powered functions



WARNING

Operating these functions changes the center of gravity and increases the risk of tipping over.

Always drive in low speed when the seating system is not in the default position. Use these functions only on horizontal plane.

To enter seating mode use MODE function of the joystick.

A wheelchair will appear on the screen of the joystick.

To select the desired function move the joystick left or right.

The number and the type of available function may change according to the specific customization of each wheelchair.

MOVE UP

Move the joystick forward while you are in seating mode and the desired function is selected

MOVE DOWN

Move the joystick rearward while you are in seating mode and the desired function is selected



INFORMATION

An authorized service center is able to customize seating functions according specific needs of single user.



PINCH HAZARD

When using powered seating functions, always pay special attention to reduce pinch risk.

AXIS 1 BACKREST

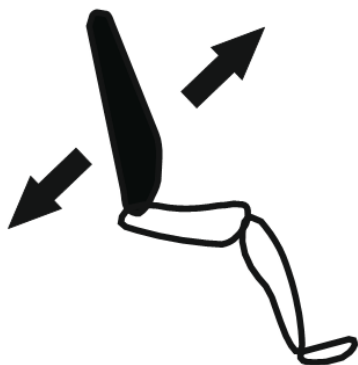

Figure 84

MOVE UP

It is possible to recline forward the backrest. An authorized service center is able to set the angle where the movement stops. When the movement stops, you will hear a sound.

MOVE DOWN

You can recline rearward the backrest. An authorized service center is able to set the angle where the movement stops. The time when the movement stops depend also on the seat angle. When the movement stops you will hear a sound.

AXIS 2 LEGREST

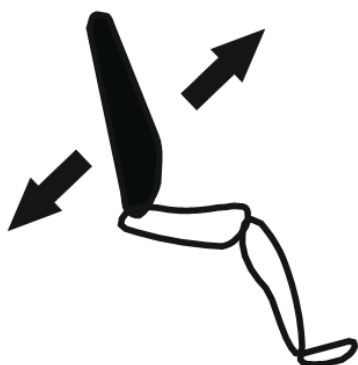

Figure 85

MOVE UP

It is possible to rise up the legrest. When the movement stops, you will hear a sound. The angle where the movement stops depends also on seat angle.

MOVE DOWN

It is possible to lower legrest. The movement stops before the legrest crashes into the chassis. In any case an authorized service center is able to choose the angle where the movement stops. When the movement stops you will hear a sound.

In any case, if during the movement, there is any danger for the legrest to crash into the floor, the seat will lift up automatically.

WARNING



Previously to move the legrest (both forward and rearward) the software checks for any danger of crashing the legrest into the floor. If any danger is revealed the seat will automatically lift.

In order to calculate the risk of crashing into the floor for the legrest the software assumes that the wheelchair is on a perfectly flat surface far from any step or obstacle. For these reasons it is very important to not use the legrest function on a non-flat surface or near steps or obstacles.

AXIS 3 TILT

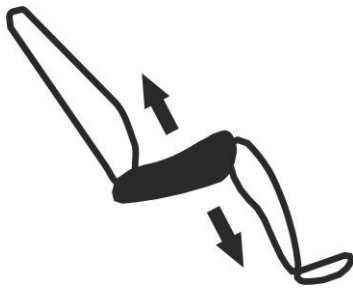

Figure 86

MOVE UP

It is possible to incline forward the seat. The movement stops when seat angle is 0°. When the movement stops you will hear a sound.

MOVE DOWN

You can recline rearward the seat. During the movement, in order to avoid uncomfortable position for the user backrest or legrest could start to move automatically. An authorized service center is able to choose the way of compensation for backrest and legrest. The movement stops when seat angle is 45°

AXIS 4 LIFT

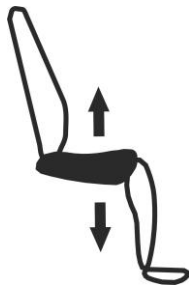

Figure 87

The seat is lifted with an innovative system that allows to better manage the center of gravity of the system wheelchair+user. They are used two different actuators at the same time.

it is needed a sophisticated software to adjust the speed of these two actuators.

This software can be fine-tuned by an authorized service center during the set-up of the wheelchair.

MOVE UP

It is possible to rise up the seat. Previously start to lift the seat, if this is forward tilted, it is firstly straightened. When seat height is 30 cm, if seat angle is 0° the movement stops, otherwise the seat will be straightened till seat angle is 0°. When the movement stops, you will hear a sound.

. When the movement stops, you will hear a sound.

MOVE DOWN

It is possible to lower the seat. During the movement it is possible that legrest or seat move automatically if there is any danger for the legrest to crash into the chassis or the floor. The movement stops when seat height is 0 cm. When the movement stops you will hear a sound.



WARNING

In order to calculate the risk for the legrest to crash into the floor the software assumes that the wheelchair is on a perfectly flat surface far from any step or obstacle. For these reasons it is very important to not use the legrest function on a non-flat surface or near steps or obstacles.

AXIS 5 REHAB



Figure 88

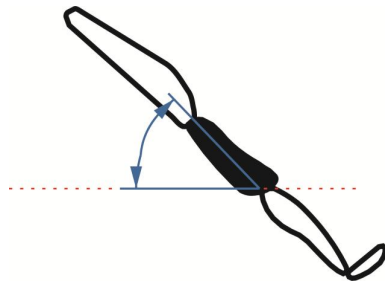

Figure 89

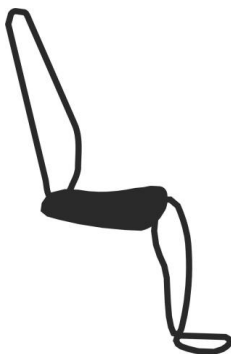

Figure 90

MOVE UP

The wheelchair will go in lay-down position and then in the position shown in Figure 89

An authorized service center is able to adjust the angles shown in figure. When the movement stops you will hear a sound.

MOVE DOWN

it is possible to bring back the wheelchair to the default position shown in Figure 90.

AXIS 6 ACTIVE NEGATIVE TILT

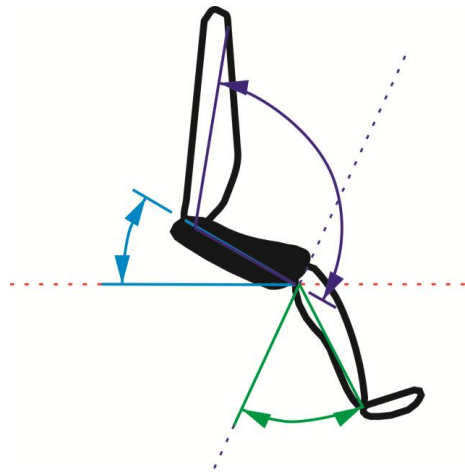

Figure 91

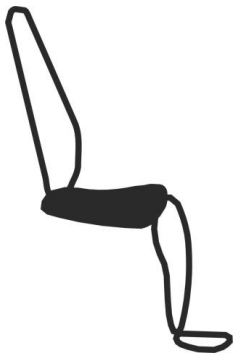

Figure 92

MOVE UP

The wheelchair will go automatically into the position shown in Figure 91.

An authorized service center is able to adjust the angles shown in figure. When the movement stops you will hear a sound.

MOVE DOWN

it is possible to bring back the wheelchair to the default position shown in Figure 92.

AXIS 7 SEMISTANDING

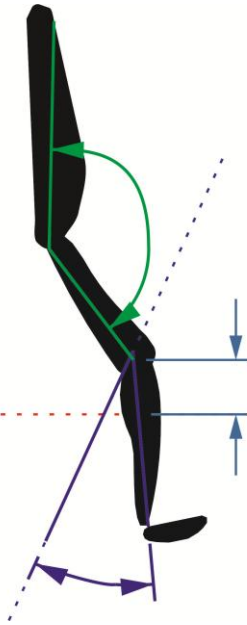

Figure 93

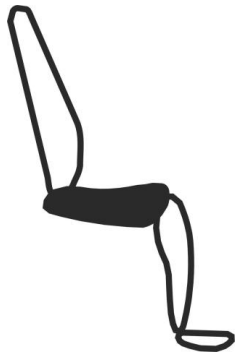

Figure 94

MOVE UP

The wheelchair will go automatically into the position shown in Figure 93.

An authorized service center is able to adjust the angles shown in figure. When the movement stops you will hear a sound.

MOVE DOWN

it is possible to bring back the wheelchair to the default position shown in Figure 94.

AXIS 8 LAY DOWN



Figure 95

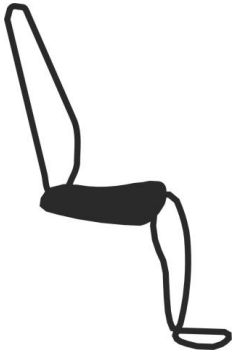

Figure 96

MOVE UP

The wheelchair will go automatically into the position shown in Figure 95.

An authorized service center is able to adjust the angles shown in figure. When the movement stops you will hear a sound.

MOVE DOWN

it is possible to bring back the wheelchair to the default position shown in Figure 96.

4.5 Main switch

Use the main switch to connect and disconnect the batteries from the power module. The switch also has the function of protecting the wheelchair from overloaded current and short circuit.

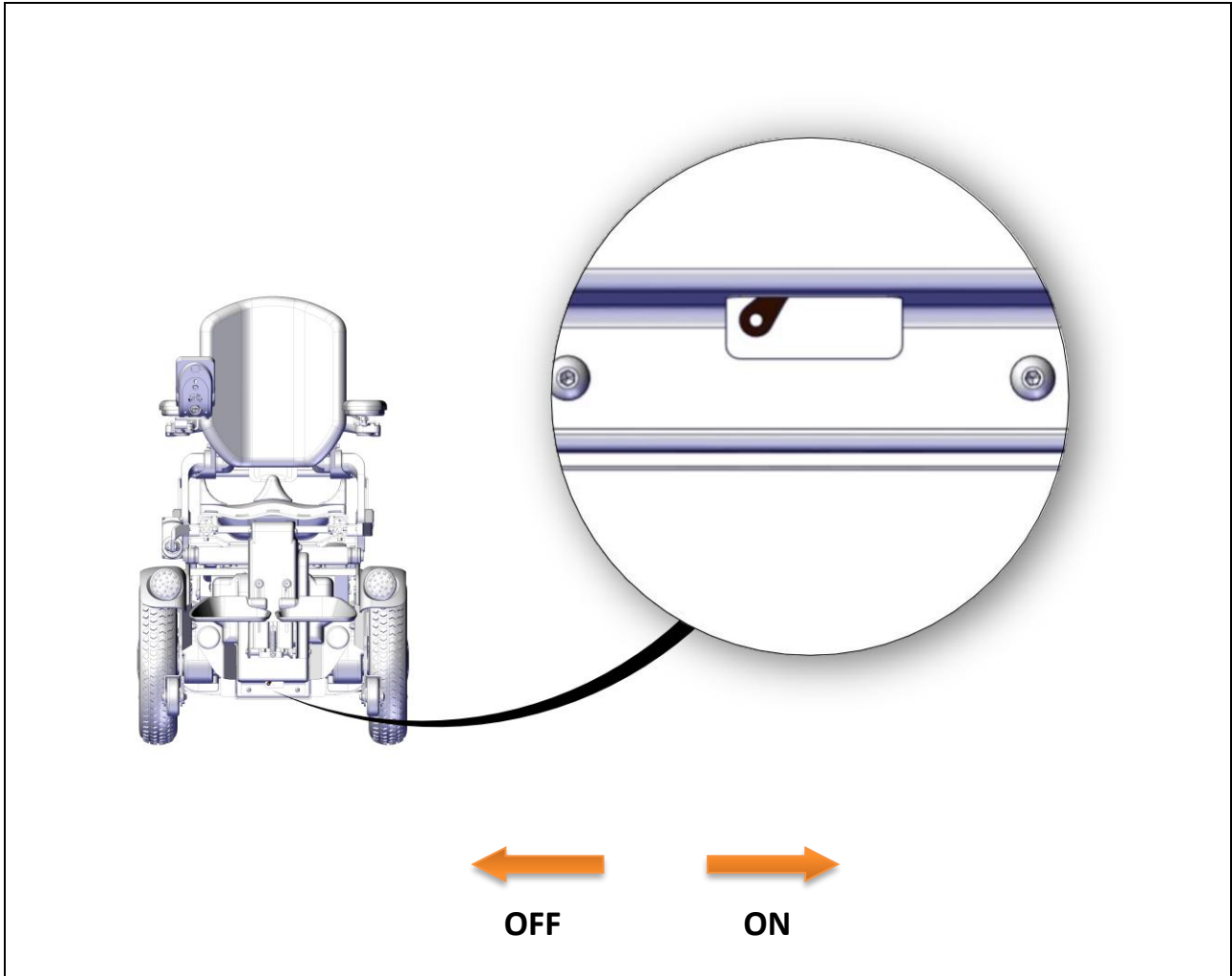
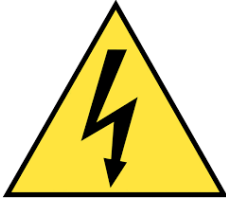

Figure 97

Figure is taken having the wheelchair on the front and shows the position ON and OFF of the switch.

If the power chair suddenly stops, use the switch to connect again batteries to the power module and turn on again the wheelchair. **If the problem still continues, it means that there is some electric fault.**

Check for any damaged cables or any damage in connections, for more information see section 5.4.



If the switch operates, often this means that there is a major electrical fault. The cause of fault should be checked carefully.



For more information, please contact the manufacturer.

4.6 Battery charging

In order to recharge batteries, use only the provided charger or one recommended by the manufacturer. The manufacturer is not responsible for any damage to person or objects resulting from the use of non-original product.



CHARGER SPECIFICATION

24 V -MIN 6 A MAX 10 A - Charge profile for AGM batteries

- Connect the power cord to a power supply 230 V.
- Connect the cable to the joystick as shown in Figure.



RNET

Figure 98

- When batteries are loaded unplug the power cord and the battery cable from the joystick.



RUNNING-IN PERIOD

Typically, batteries are able to offer 100% performance after about 15-20 cycles.



CHARGER SPECIFICATION

24 V MIN 6 A MAX 10 A - Charging profile for GEL batteries

WHEN AND HOW IT IS NECESSARY TO CHARGE BATTERIES?



It is very important to charge batteries every day, even if they are not completely discharged. Each battery is subject to a normal self-discharge, so batteries that are not used for long time will discharge by itself.

It is very important to don't let batteries uncharged for long time.

It is very important to complete every cycle of charging

Charging time is influenced by multiple factors such as remaining battery power, battery state of aging and temperature. However, the approximate charging time is about 12 hours.



Battery charging should be done in well ventilated environments. Never charge in bathroom or wet room.

When the charger is connected it is not possible to drive the wheelchair. Don't use the wheelchair during the charge.

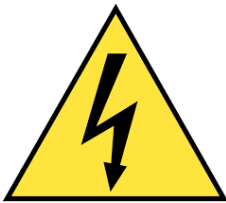

SHOCK HAZARD

Check if charger requirements data matches with the network power (voltage, frequency)



RELEASE DANGER

Any impact to the batteries could cause a loss of fluids. Please pay special attention.



BATTERIES DISPOSAL

To properly recycle the batteries follow instructions provided by your local waste disposal service.

4.7 Transport and storage

If you are not willing to use the wheelchair for a long period, keep it safe in a clean area and away from heat.

If it is necessary to transport the wheelchair to facilitate operation follow these instructions.

It is possible to store the wheelchair in a place with a temperature between $-20\text{ }^{\circ}\text{C}$ and $+45\text{ }^{\circ}\text{C}$.

- Turn off the wheelchair.
- Turn off the main switch. See section 4.5.



WARNING

If you transport the wheelchair with motors disengaged, the wheelchair is free to move. This may result in a hazardous situation.

4.7.1 Batteries removal

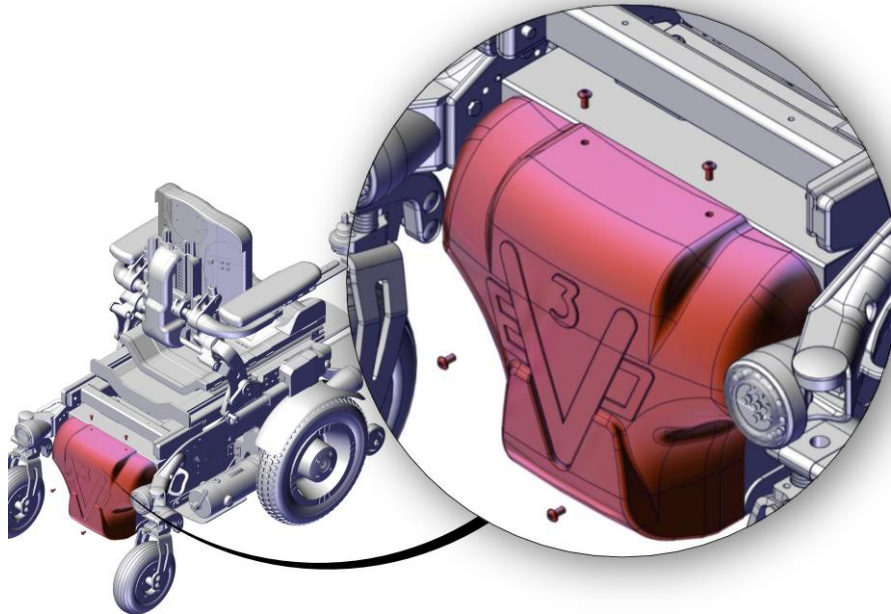

Figure 99

- Unscrew the 4 screws shown in figure.
- Remove the cover.

ALLEN WRENCH



3 mm

NEATECH

MISSING IMAGE

Figure 100

- Unplug the connectors shown in figure.

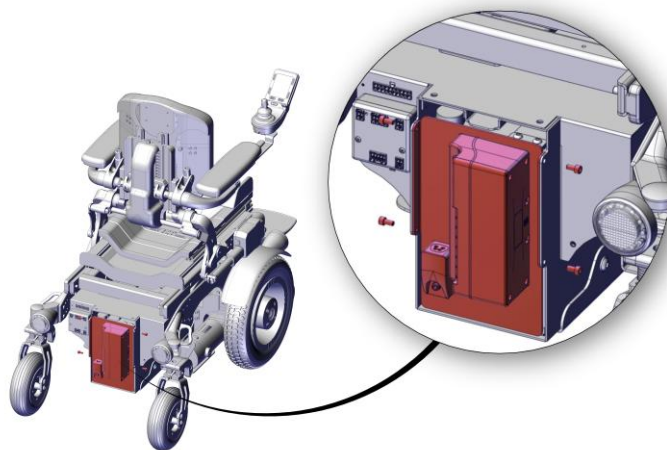

Figure 101

- Unscrew the 4 screws shown in figure.
- Remove the metalsheet with mounted modules. **It is not necessary to unplug any wires.**
- Pull away the batteries pack.

ALLEN WRENCH



4 mm

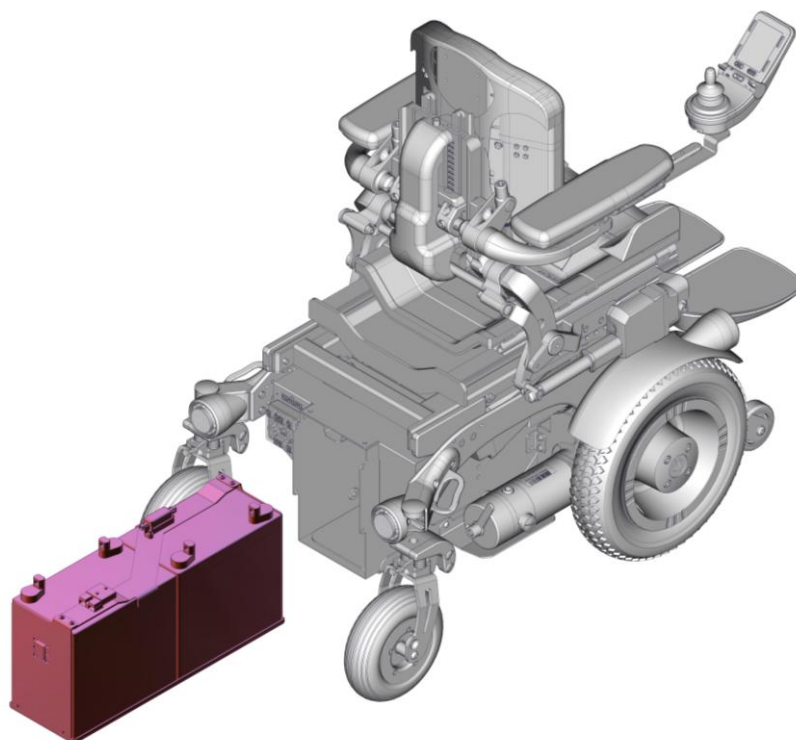

Figure 102

- Unscrew the 4 screws shown in figure.



WARNING

Batteries are mounted in a metal enclosure. Total weight is about 40 kg. Please do not remove batteries from their enclosure. Please pay special attention.

WARNING

In the upper part of batteries housing there are two plastic sheets useful to reduce short circuit risk. When placing back batteries please be sure that they are correctly fixed in their proper place.

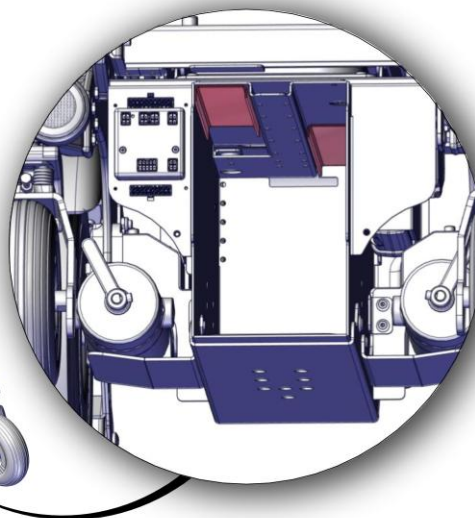
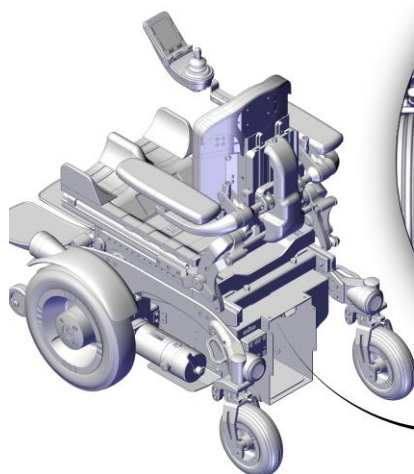

Figure 103



BATTERIES SPECIFICATION

2 x 12 V – 50 Ah – GEL Type

MAX 228 mm x 139 mm x 235 mm (h)

The wheelchair can be transported in the storage compartment of the vehicle even without any package. The unoccupied wheelchair can be also shipped via air. If it is necessary to ship the wheelchair it is very important to protect it with an appropriate package.

It is not possible to provide a universal package, so the user should provide himself for it. The used package must be water and dust resistant and strong enough to protect the wheelchair from any hurts. When inserting the wheelchair into the package protect any protruding parts with some foam or similar.

5 MAINTENANCE

Please remind that the wheelchair is intended exclusively for the carriage of seated people. Below there are some precautions for the use of the wheelchair, which it is recommend to follow, in order to ensure a safe use and a long duration.

Regular maintenance helps to keep intact the functionality and safety of the wheelchair. Inadequate or lack of care and maintenance may cause a limitation of the warranty.

- Avoid prolonged contact of the wheelchair with water. It may cause oxidation of the metal parts.
- Avoid long exposure of the wheelchair to direct sunlight.



WARNING

Any work on the wheelchair must be performed by an authorized service center.



INFORMATION

It is not possible to perform any maintenance on batteries. It is only possible to substitute them.

5.1 Maintenance and cleaning

To clean the wheelchair do not use high-pressure water spray devices. For plastic and metal parts use a soft cloth dampened with mild detergent. For the upholstery, linings, seat and back covers use warm water and mild detergent. Do not use stain removers, solvents, acids, etc.

5.2 Controls to be performed on the product

Type of operation	
A	Operation intended to be performed by the user.
B	Operation intended to be performed by an assistant.
C	Operation intended to be performed by an authorized service center.

Operation	Frequency	Type of operation
Check if motors are correctly locked. See section 4.2.	Before each use	B - Assistant
Check that no wires are in the way for the movements of the chair	Before each use	B - Assistant
Check the charge of batteries	Daily	A - User
Clean the wheelchair	Weekly	B - Assistant
Check if the pressure is the one indicated on tires and in section 6 Traction wheels: 280 kPa; Castors: 250 kPa.	Weekly	B - Assistant
Check if the lever of the main switch works correctly	Weekly	B - Assistant
Check tire usury	Monthly	B - Assistant
Check brake release lever	Monthly	B - Assistant
Check aging of batteries	Monthly	C – Service

5.3 Tire puncture

5.3.1 User information

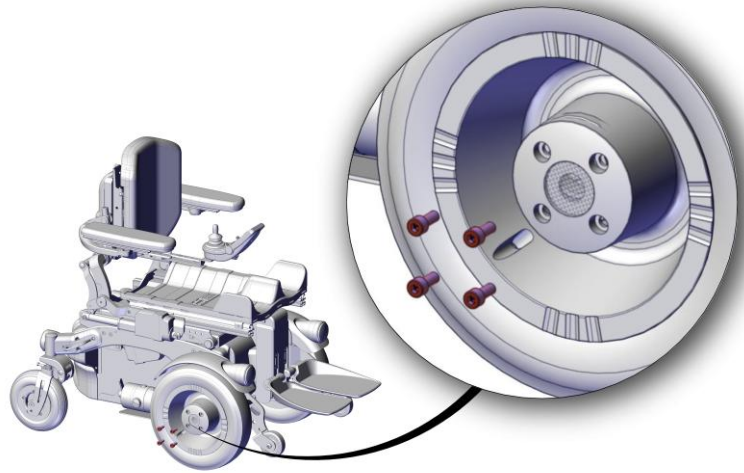

Traction wheels

Figure 104

- Lift the wheelchair.
- Unscrew the 4 screws shown in figure.
- Remove the wheel.

ALLEN WRENCH



6 mm

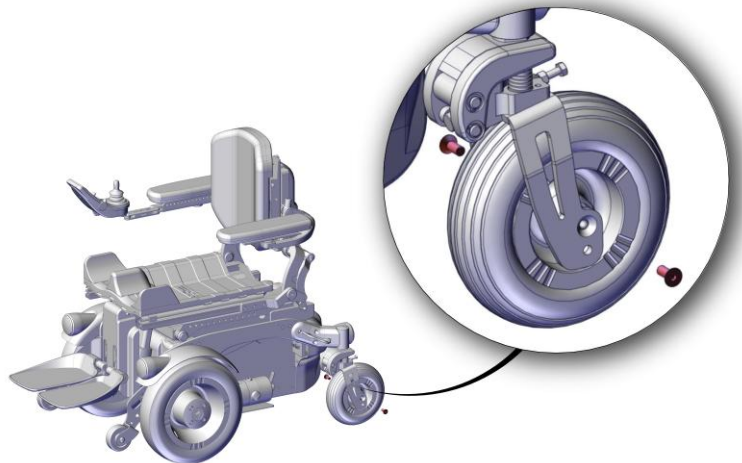

Figure 105

- Lift the wheelchair.
- Unscrew the 2 screws shown in figure using at the same time two allen wrenches.
- Remove the castor.

ALLEN WRENCH



5 mm

ALLEN WRENCH



5 mm



Contact an authorized service center for the repair or the substitution of the damaged wheel. When the authorized service center gives you back the repaired wheel or a new one, mount it following instructions in reverse order.

INFORMATION

With wheels $\varnothing 320$ S042-V620 it is necessary to mount the screws of the castor in holes (A). With wheels 3.00-8 it is necessary to mount the screws of the castor in holes (B).

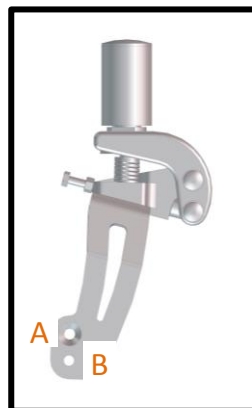

Figure 106

5.3.2 Service information

When the user requires assistance for a punctured wheel, according to the entity of damage, decide if it is better to repair or substitute the wheel.

Code	Description	Type of operation
R042-0120A	Traction wheel Pneumatic Gray Ø320x58 mm	A
R042-0120B	Traction wheel Pneumatic Black Ø320x58 mm	A
R042-0120C	Traction wheel Pneumatic Gray Ø360x80 mm	A
R042-0120D	Traction wheel Pneumatic Black Ø360x80 mm	A
R042-0121A	Tire of traction wheel gray Ø320x58 mm	B
R042-0121B	Tire of traction wheel black Ø320x58 mm	B
R042-0121C	Tire of traction wheel gray Ø360x80 mm	B
R042-0121D	Tire of traction wheel black Ø360x80 mm	B
R042-0122A	Tube of traction wheel Ø320 mm	B
R042-0122B	Tube of traction wheel Ø360 mm	B
R042-0131A	Castor Pneumatic gray Ø200 mm x 50 mm	A
R042-0131B	Castor Pneumatic black Ø200 mm x 50 mm	A
R042-0132A	Tire of castor gray Ø200 mm x 50 mm	B
R042-0132B	Tire of castor black Ø200 mm x 50 mm	B
R042-0133	Tube for castor Ø200 mm x 50 mm	B

Table 20

A - Power module

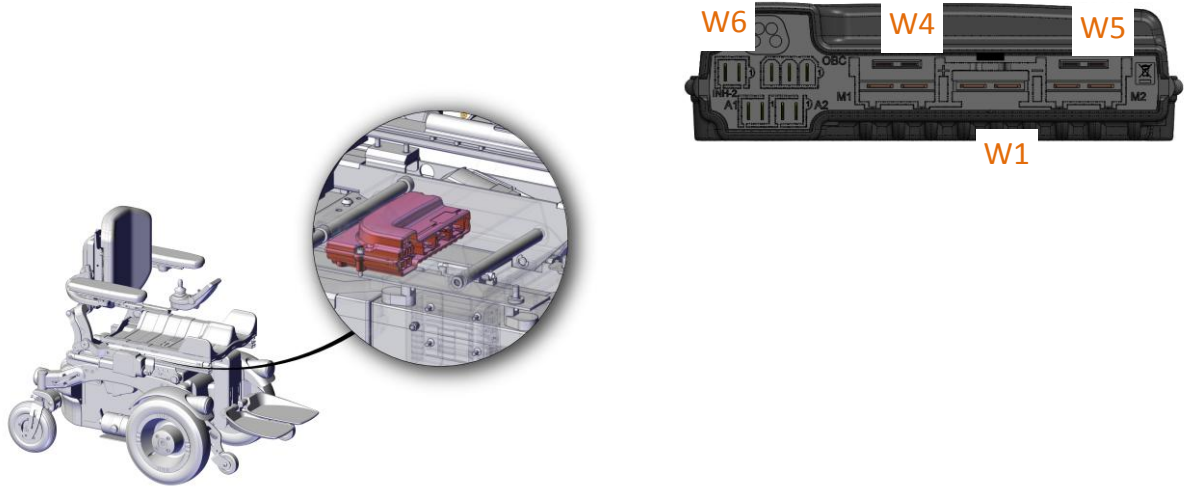

W1

Battery pack and main switch

W4

Motor 1 left

(included in motor)

W5

Motor 2 right

(included in motor)

W6

Connector block

B - Battery pack and main switch

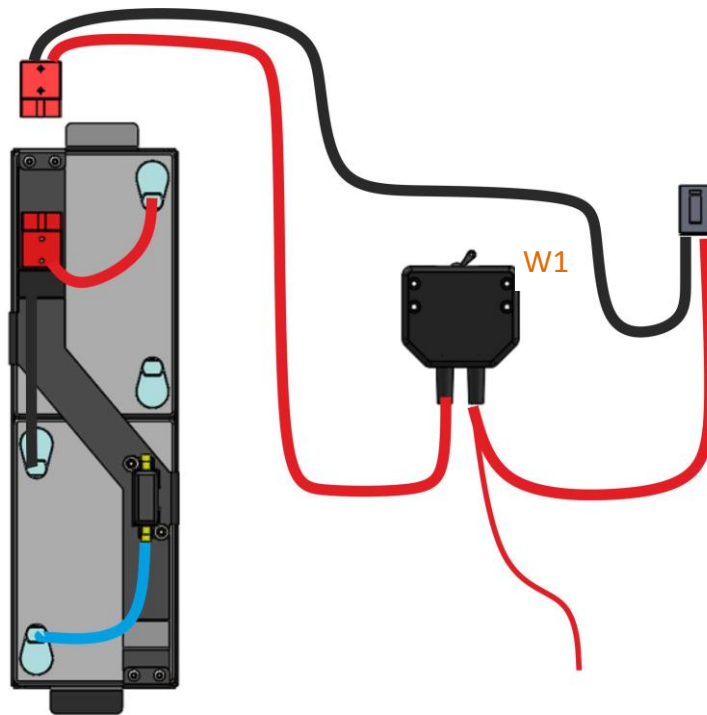
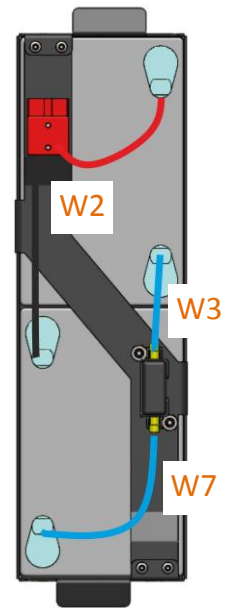
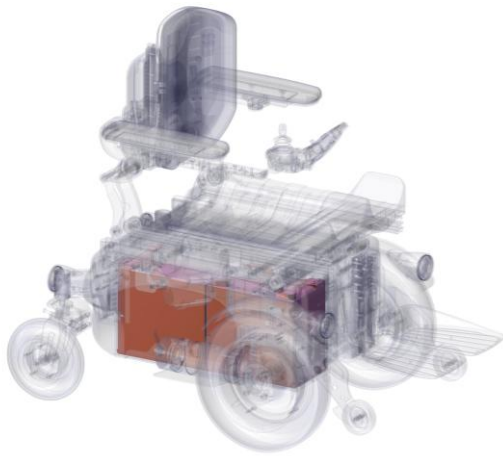

W1

Power module

C - Connector board

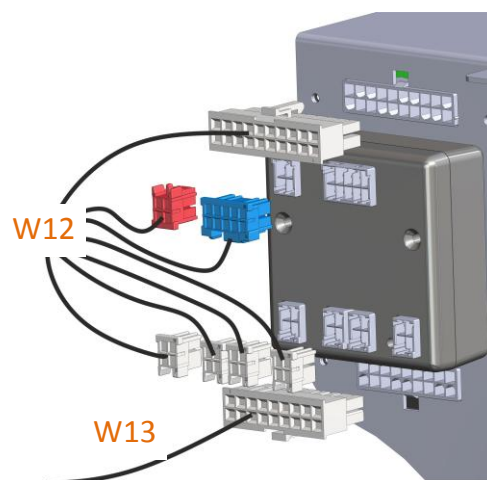
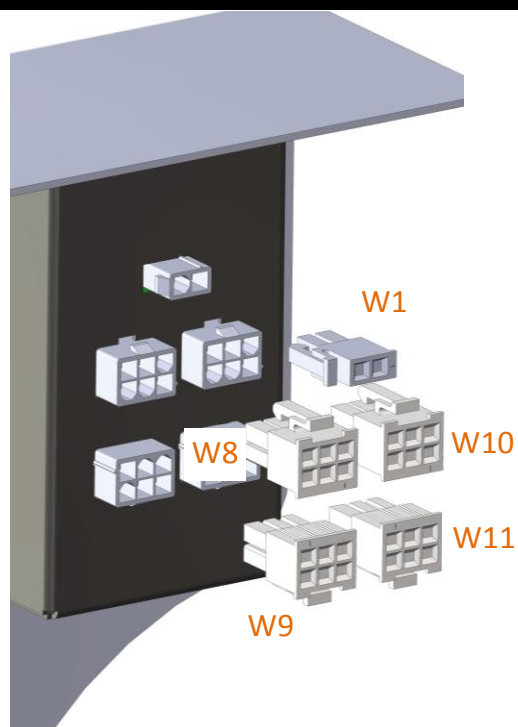
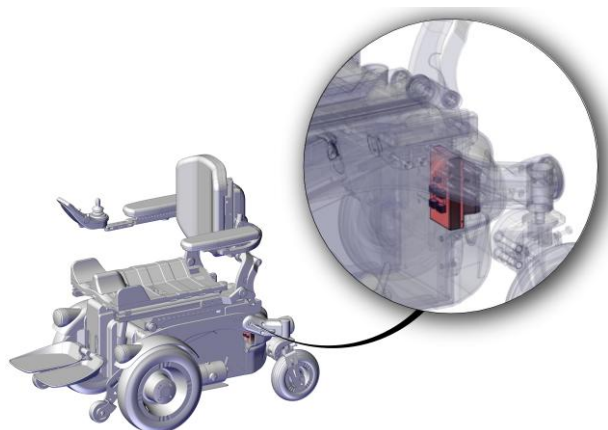

W1	Battery pack and main switch
W8 included in actuator	Actuator 2
W9 included in actuator	Actuator 1
W10 included in actuator	Actuator 4
W11 included in actuator	Actuator 3
W13 included in actuator	Seating module

INFORMATION

Please note that wires W8, W9, W10, W11 have some yellow rings with numbers 1, 2, 3, 4 to identifies actuators. Connect them to the board as shown in figure.

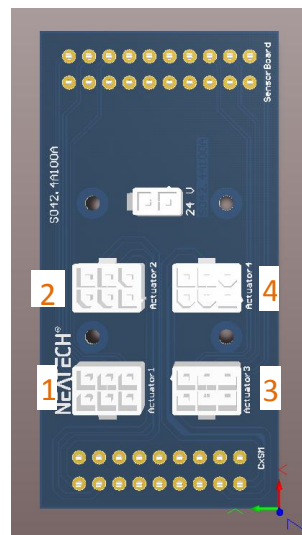

Figure 108

INFORMATION

Please note that wire W12 has 1 red connector (R), 1 blue connector (B) and 4 white connectors. The 4 white connectors have some yellow rings with numbers 1, 2, 3, 4. Please connect them to the board as shown in figure.

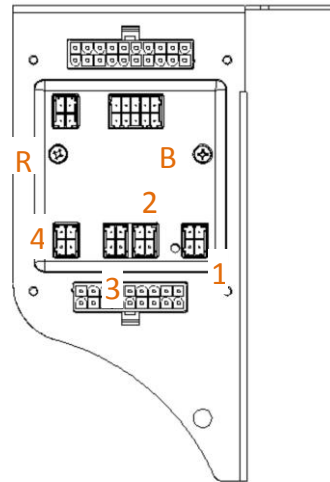
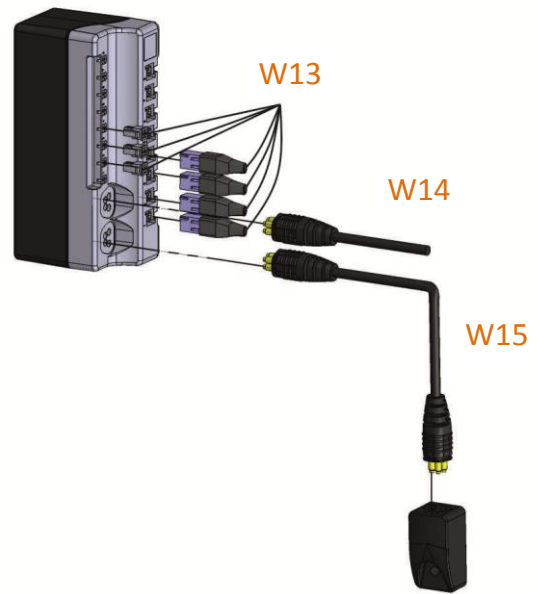
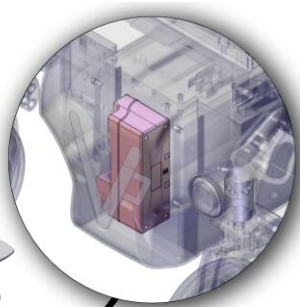
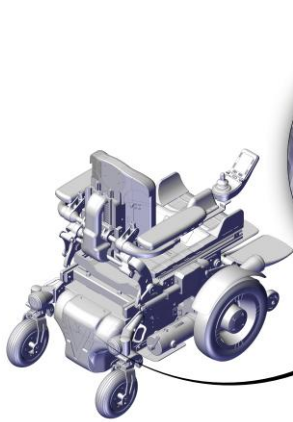

Figure 109

D - Seating module and gyro



W13

Connector board

W14 included in actuator

Connector block

INFORMATION

Please note that wire W13 has 4 big connector and 3 smaller ones. Each big connector has a yellow ring with numbers 1, 2, 3, 4 to identify wires. Each small connector has a yellow ring with numbers 2, 3, 4 to identify wires. Please connect them to the board as shown in figure.

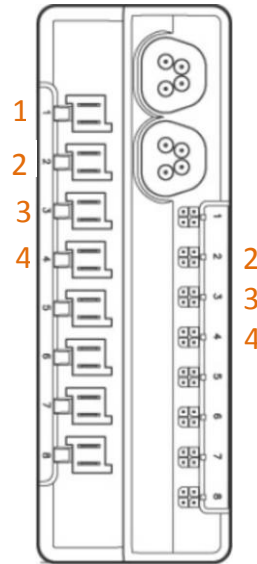
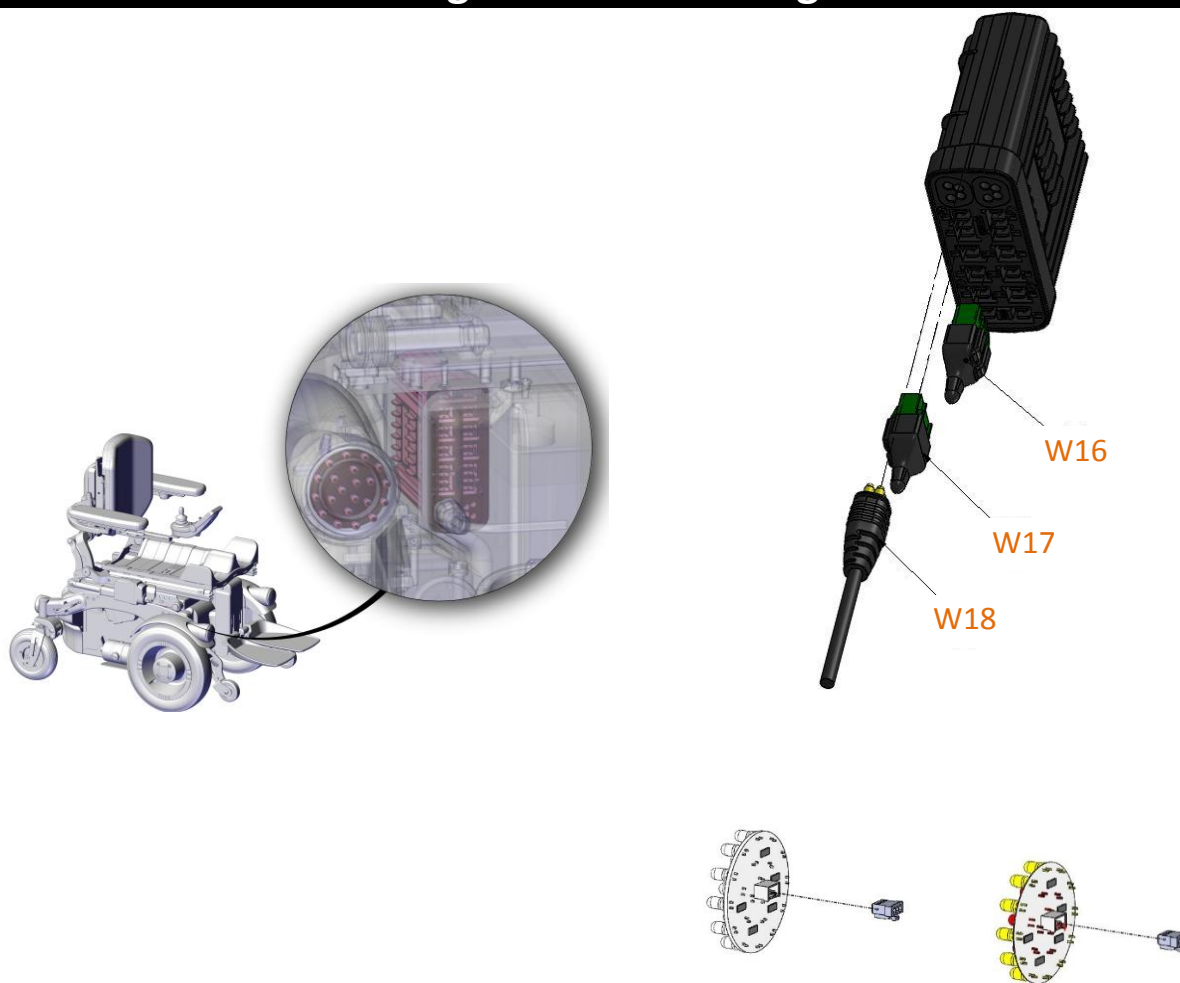

Figure 110

E - Light module and lights



W16

Lights LH

W17 included in actuator

Lights RH

W18

Connector block

F - Connector block

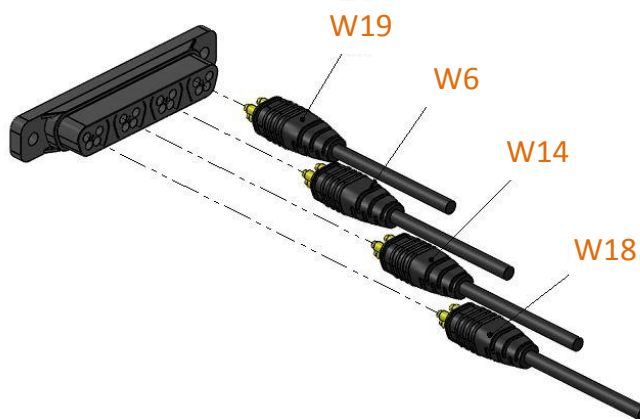
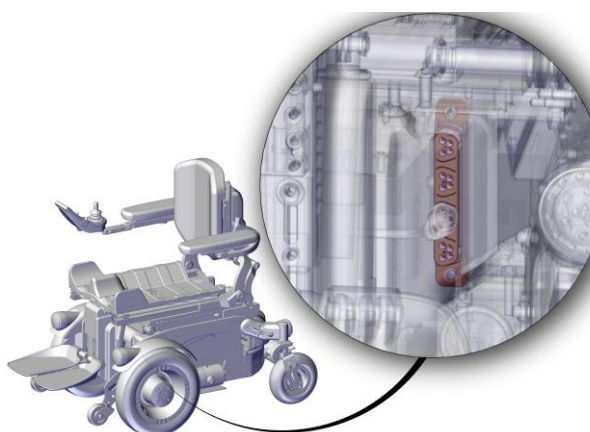

W19

Joystick

W6 included in actuator

Power module

W14

Seating module

W18

Light module

I
c

5.5 Batteries replacement

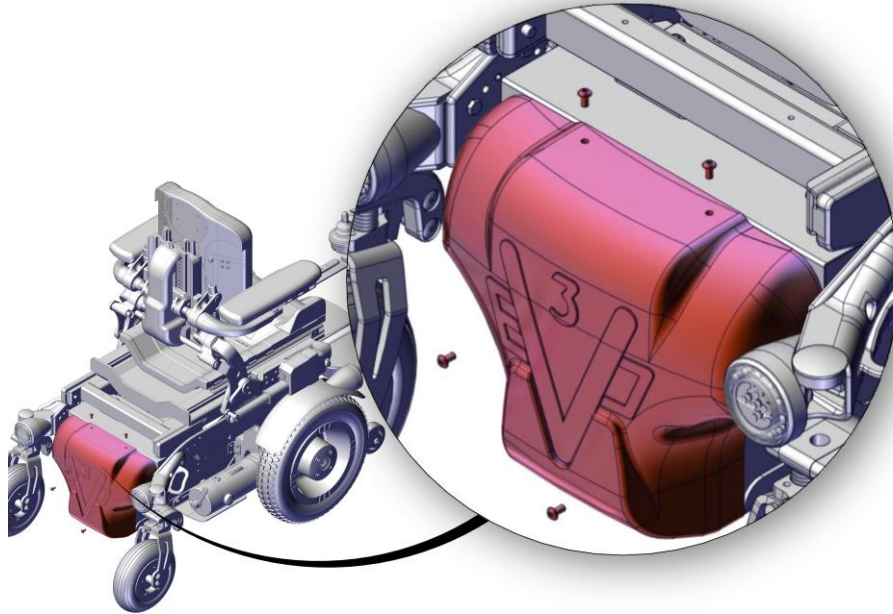

Figure 111

- Unscrew the 4 screws shown in figure.
- Remove the cover.

ALLEN WRENCH



3 mm

NEATECH

MISSING IMAGE

Figure 112

- Unplug the connectors shown in figure.

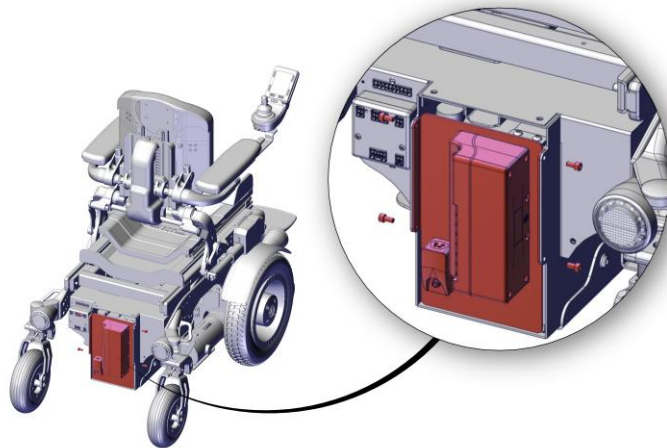

Figure 113

- Unscrew the 4 screws shown in figure.
- Remove the metalsheet with mounted modules. **It is not necessary to unplug any wires.**
- Pull away the batteries pack.

ALLEN WRENCH



3 mm

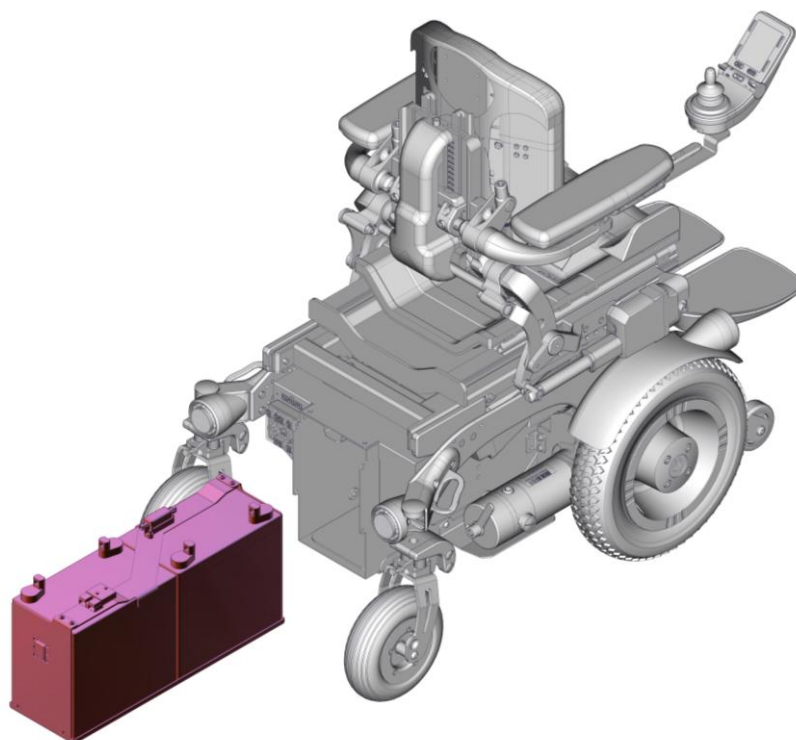

Figure 114

- Pull away batteries.



WARNING

Batteries are mounted in a metal enclosure. Total weight is about 40 kg.
Please do not remove batteries from their enclosure.

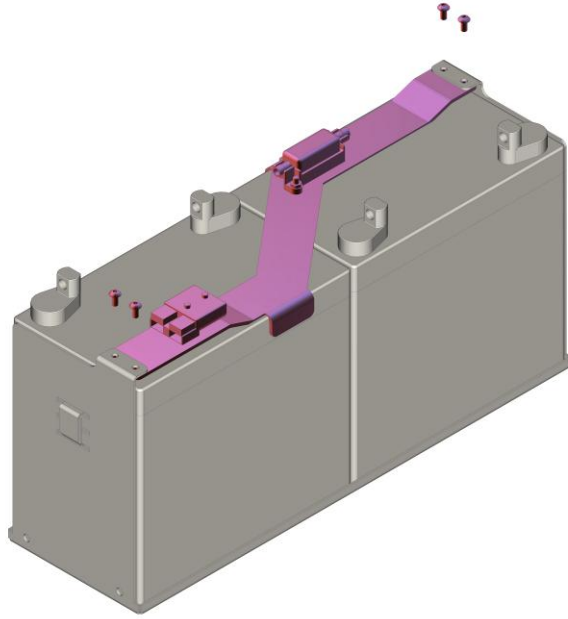

Figure 115

- Unscrew the 4 screws shown in figure.
- Remove the metallic handle.

ALLEN WRENCH



3 mm



Figure 116

- Remove cables from the batteries.
- Mount new batteries following instructions in reverse order.

ALLEN WRENCH



5 mm



WARNING

Each battery weights about 18 kg. Please pay special attention.

WARNING

In the upper part of batteries housing there are two plastic sheets useful to reduce short circuit risk. When placing back batteries please be sure that they are correctly fixed in their proper place.

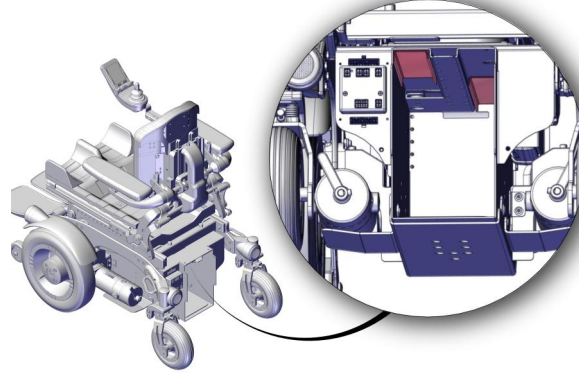

Figure 117



BATTERIES SPECIFICATION

2 x 12 V – 50 Ah – GEL Type
MAX 228 mm x 139 mm x 235 mm (h)

Code	Description	Type of operation	Notes
R042-0110	Batteries	B	

5.6 Reuse

The product is suitable for reuse. Before dispensing it, the product must be cleaned, and subjected to maintenance. The operating instructions are included in this manual and must also be provided when the product is passed on.



WARNING

This operation must be performed only at an authorized service center.

5.7 Spare parts

Type of operation	
A	Parts that can be bought at an authorized service center and substitute autonomously
B	Parts that need to be substituted at an authorized service center.

Table 21

Code	Description	Type of operation	Notes
R042-0110	Batteries	B	
R042-0120	Traction wheel	A	
R042-0121	Tire for traction wheel	B	
R042-0122	Tube for traction wheel	B	
R042-0130	Castor with fork	B	
R042-0131	Castor	A	
R042-0132	Tire for castor	B	
R042-0133	Tube for castor	B	
R042-0134	Fork with dump	B	
R042-0135	Bearings	B	
R042-0136	Spring kit for castor	B	
R042-0140	Antitip wheel	A	
R042-0150	Cover A	A	
R042-0160	Cover B	A	
R042-0170	Motors - couple	B	
R042-0180	Main switch	B	
R042-0181	lever for main switch	A	
R042-0182	Fuse PCB	B	
R042-0190	Joystick support	A	
R042-0200	Joystick	A	
R042-0210	Power module	B	
R042-0220	Seat module	B	
R042-0230	Charger	A	
R042-0250	Kit light for castor	A	
R042-0251	Light for castor	A	
R042-0252	Castor cover	A	
R042-0270	Mudguard kit	A	
R042-0271	Light for mudguard	A	
R042-0280	Bumpers for motors	B	
R042-0290	Gyroscope	B	
R042-0300	Light module	B	

Table 22

Spare parts only for wheelchair with biomechanics movements

Code	Description	Type of operation	Notes
R042-0311	Legrest cover	A	
R042-0312	Legrest belt	B	
R042-0313	Legrest actuator	A	
R042-0314	Excursion metalsheet for legrest	B	
R042-0315	Legrest spring	B	
R042-0320	Footplates	A	
R042-0330	Tilt actuator	B	
R042-0340	Lift actuator	B	
R042-0360	Backrest actuator	A	
R042-0371	Backrest cover	A	
R042-0372	Ruler for armrest adjustment	B	
R042-0373	Joint for armrest	A	
R042-0380	Armrest	A	
R042-0390	Connector and sensor board	B	

Table 23

Spare parts only for wheelchair with biomechanics movements



WARNING

The use of spare parts or accessories not approved by the manufacturer may make the wheelchair unstable or uncontrollable.

For each order, always contact an authorized service center.



CONTACT INFORMATION

For any other part not described in this manual please contact the manufacturer.

5.7.1 Fork with dump



Average needed time:

10 min



Difficulty level:

Easy

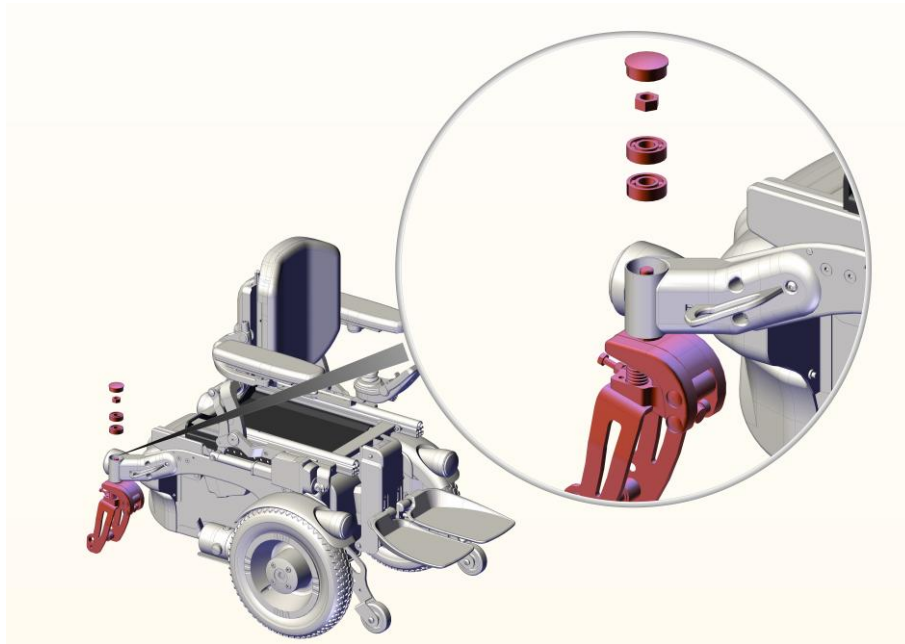

Figure 118

- Remove the castor. See section 5.3.1
- Remove the cap shown in figure. Use a screwdriver as a lever.
- Unscrew the nut shown in figure. use a 19 mm open-end wrench.
- Substitute the fork with dump.
- If desired, it is also possible to substitute only bearings.
- Mount the old castor. See section 5.3.1 .

SCREWDRIVER



OPEN-END WRENCH



19 mm

If desired, it is also possible to substitute only springs.



Figure 119

- Remove the seeger shown in figure. Use a screwdriver as a lever.
- Remove the axis shown in figure. Remove the axis shown in figure. Unscrew the nut shown in figure. use a 19 mm open-end wrench.

SCREWDRIVER



INFORMATION

In order to facilitate this operation, it is possible to press the shock absorber, for example with a clamp.



INFORMATION

When performing this operation, parts shown in figure will be disassembled. Please pay special attention because it will be necessary to remount them in the same order.



Figure 120



Figure 121

- Substitute the springs shown in figure. Remove the axis shown in figure. Remove the axis shown in figure. Unscrew the nut shown in figure. use a 19 mm open-end wrench.

Code	Description	Type of operation	Notes
R042-0134	Fork with dump	B	
R042-0135	Bearings	B	
R042-0136	Spring kit for castor	B	

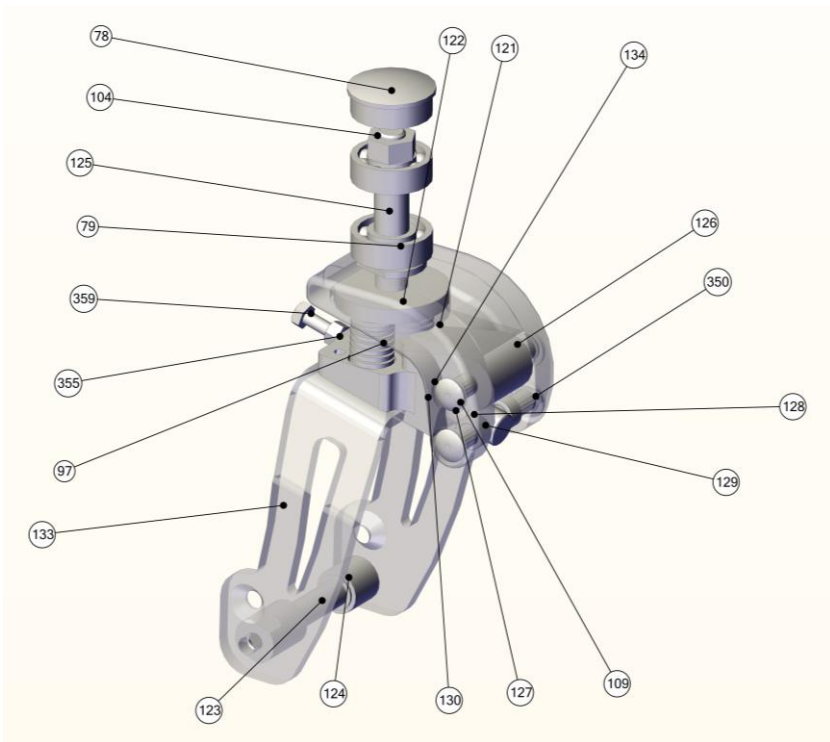

Figure 122

Code	ID	Quantity
R042-0134	359	1
R042-0134	355	1
R042-0134	350	2
R042-0134	134	1
R042-0134	133	1
R042-0134	130	1
R042-0134	129	2
R042-0134	128	1
R042-0134	127	1
R042-0134	126	2
R042-0134	125	1
R042-0134	124	1
R042-0134	123	1
R042-0134	122	1
R042-0134	121	1
R042-0134	109	1
R042-0134	104	1
R042-0134	97	2
R042-0134	79	2
R042-0134	78	1
R042-0135	79	2
R042-0136	97	2

5.7.2 Antitip wheels



Average needed time:

5 min



Difficulty level:

Easy

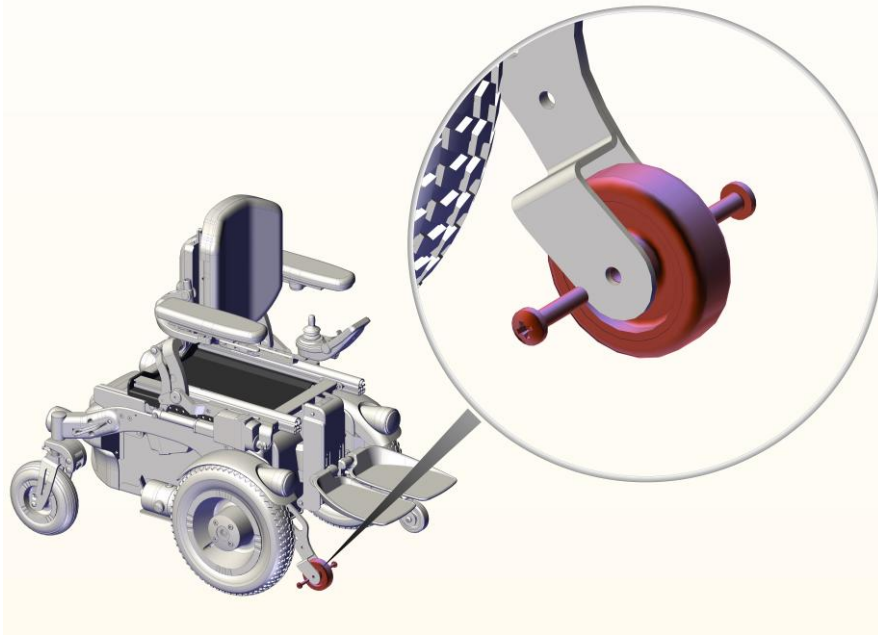

Figure 123

- Unscrew the screws shown in figure.
- Substitute the wheel.
- Screw the new screws.
- Repeat operations for both left and right side of the wheelchair.

SCREWDRIVER

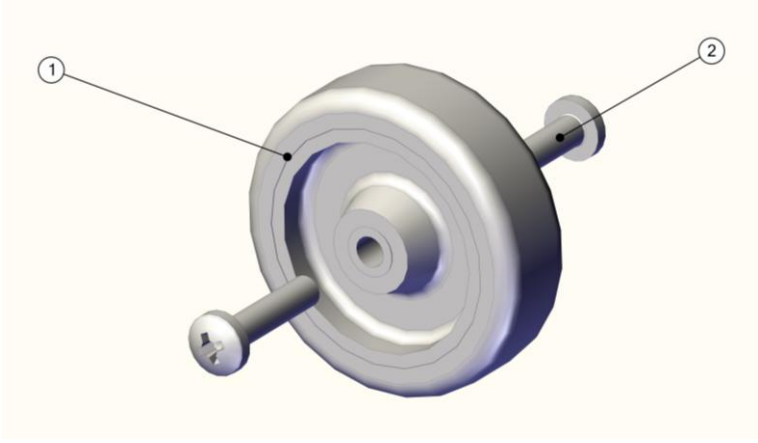

Code	Description	Type of operation	Notes
R042-0140	Antitip wheel	A	

 <p style="text-align: center;">Figure 124</p>	Code	ID	Quantity
	R042-0140	1	1
	R042-0140	2	2

5.7.3 Cover A



Average needed time:

5 min



Difficulty level:

Easy



In order to safely perform this operation, it is necessary to activate some powered seat functions. In case of problems with the seating system, please contact the manufacturer.

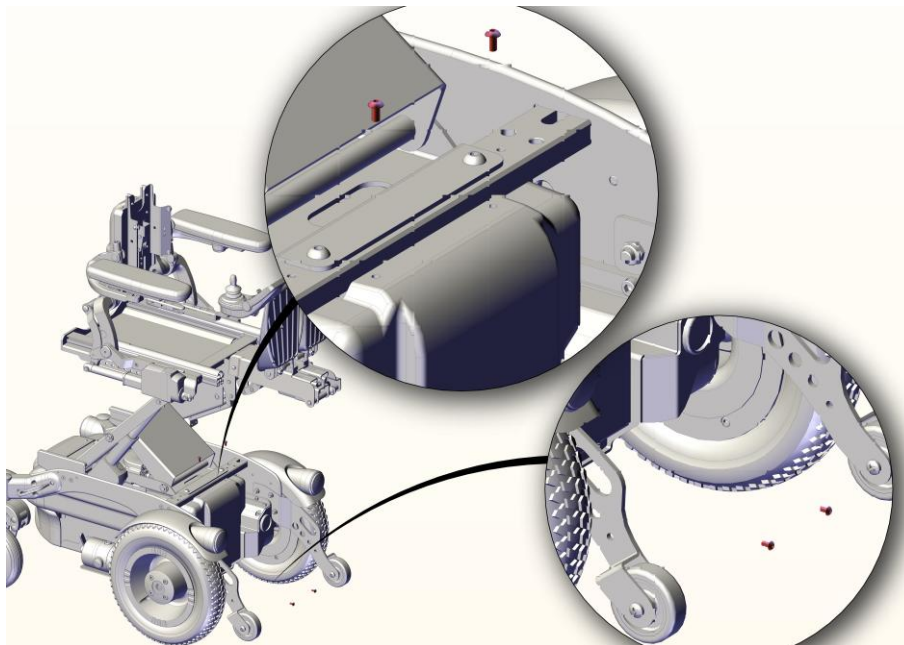

Figure 125

- Lift the seat and raise legrest.
- Unscrew the screws shown in figure.
- Substitute the cover.
- Screw the new screws.

ALLEN WRENCH



3 mm

Code	Description	Type of operation	Notes
R042-0150	Cover A	A	

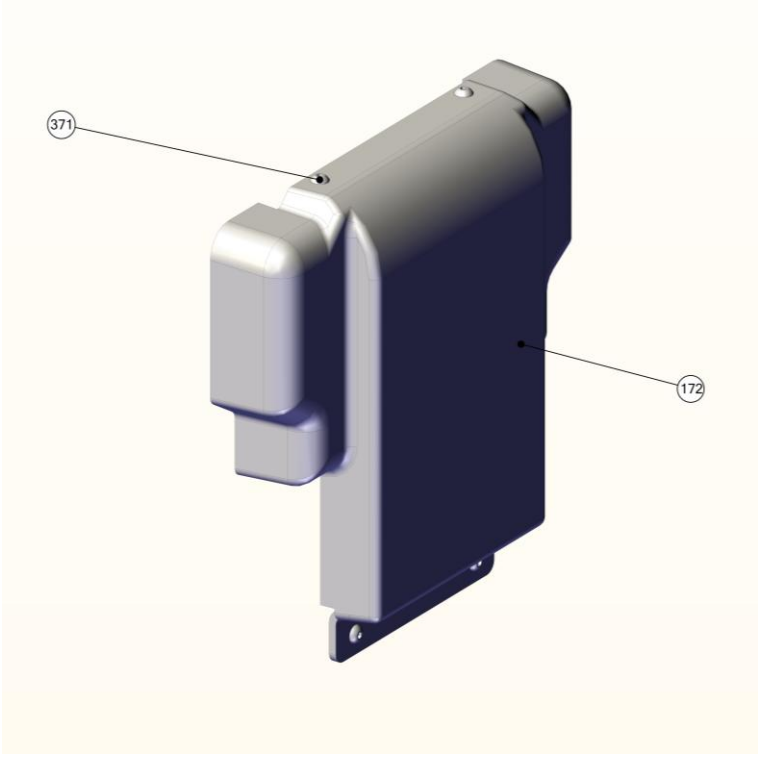
 <p>Figure 126</p>	Code	ID	Quantity
	R042-0150	172	1
	R042-0150	371	4

5.7.4 Cover B



Average needed time:

5 min



Difficulty level:

Easy

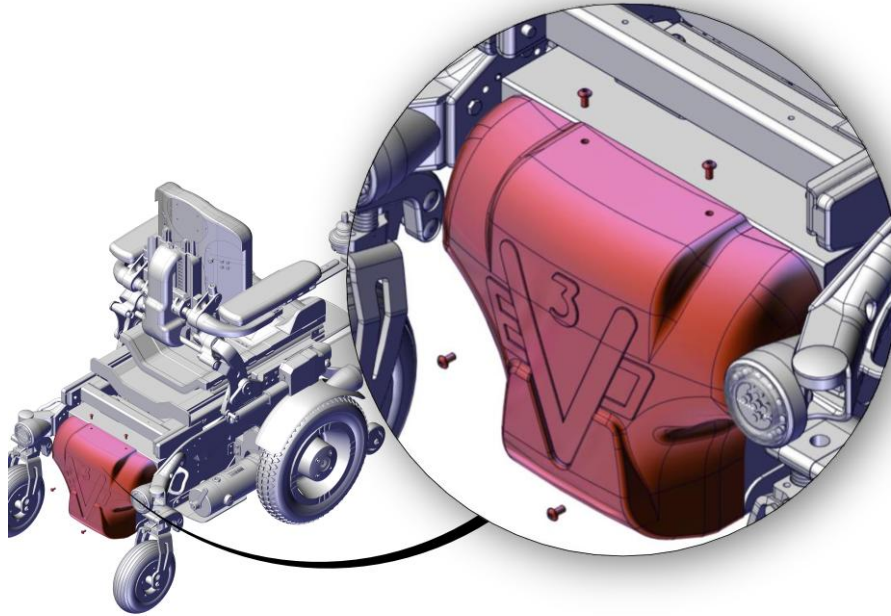

Figure 127

- Unscrew the screws shown in figure.
- Substitute the cover.
- Screw the new screws.

ALLEN WRENCH



3 mm

Code	Description	Type of operation	Notes
R042-0160	Cover B	A	

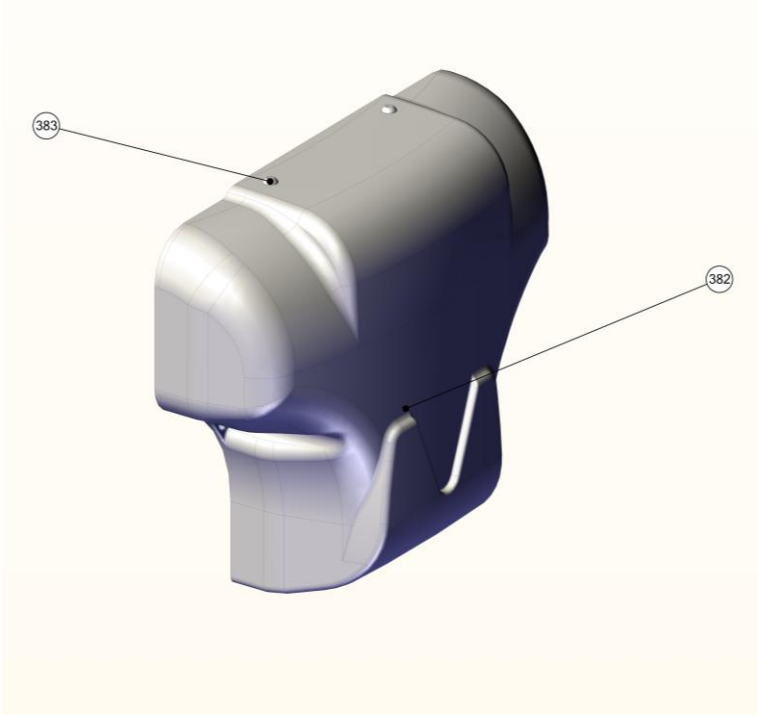
 <p style="text-align: center;">Figure 128</p>	Code	ID	Quantity
	R042-0160	382	1
	R042-0160	383	4

5.7.5 Motors



Average needed time:

45 min



Difficulty level:

Medium



In order to safely perform this operation, it is necessary to activate some powered seat functions. In case of problems with the seating system, please contact the manufacturer.

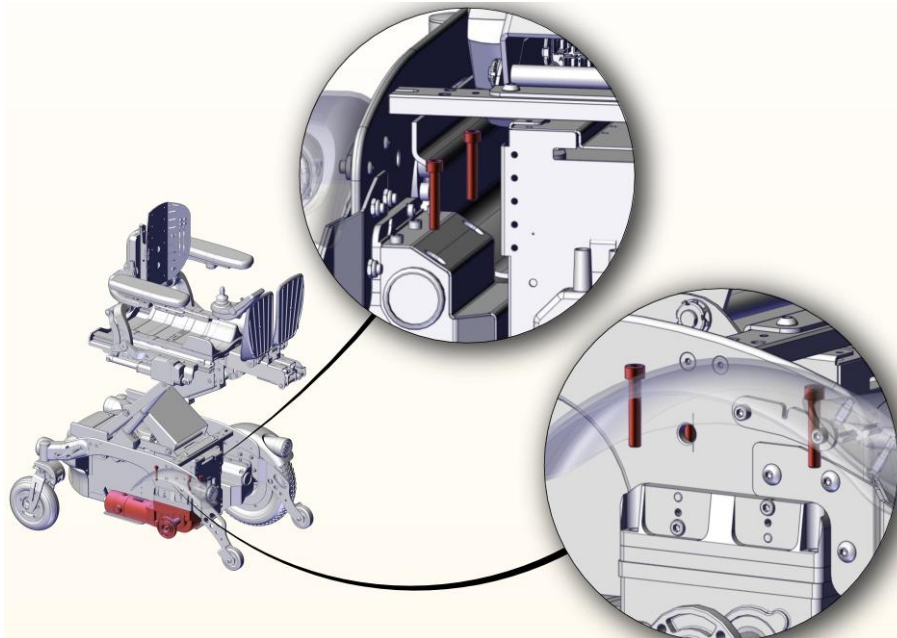

Figure 129

- Lift the seat.
- Remove the traction wheel. See section 5.3.1
- Remove the cover A. See section 5.7.3 .
- Remove the light module. See section 5.7.16 .
- Unplug connector of motor from the power module. See section 5.4.
- Unscrew the screws shown in figure.
- Substitute the motor following instructions in reverse order.

ALLEN WRENCH



6 mm

Code	Description	Type of operation	Notes
R042-0170	Motor	B	

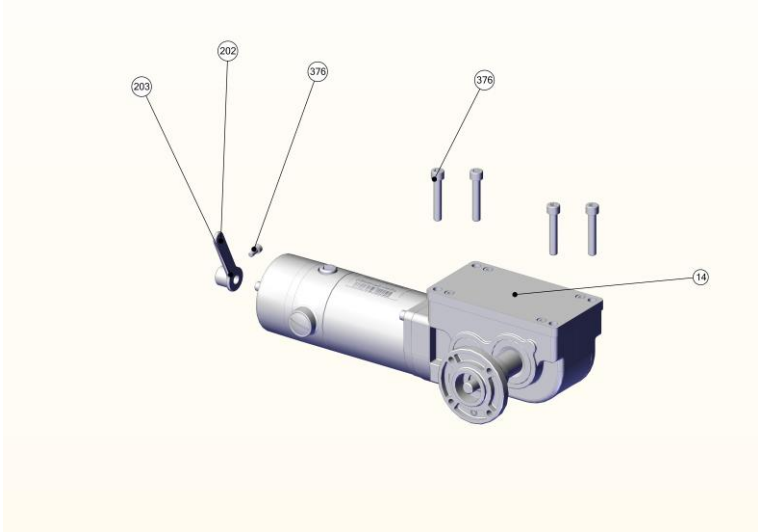
 <p>Figure 130</p>	Code	ID	Quantity
	R042-0170	202	1
	R042-0170	203	1
	R042-0170	376	4
	R042-0170	385	1
	R042-0170	14	1



WARNING

When performing this operation, it is necessary to reprogram the wheelchair. For more information see section 2.1.2 ..

5.7.6 Main switch



Average needed time:

5 min



Difficulty level:

Easy



In order to safely perform this operation, it is necessary to activate some powered seat functions. In case of problems with the seating system, please contact the manufacturer.

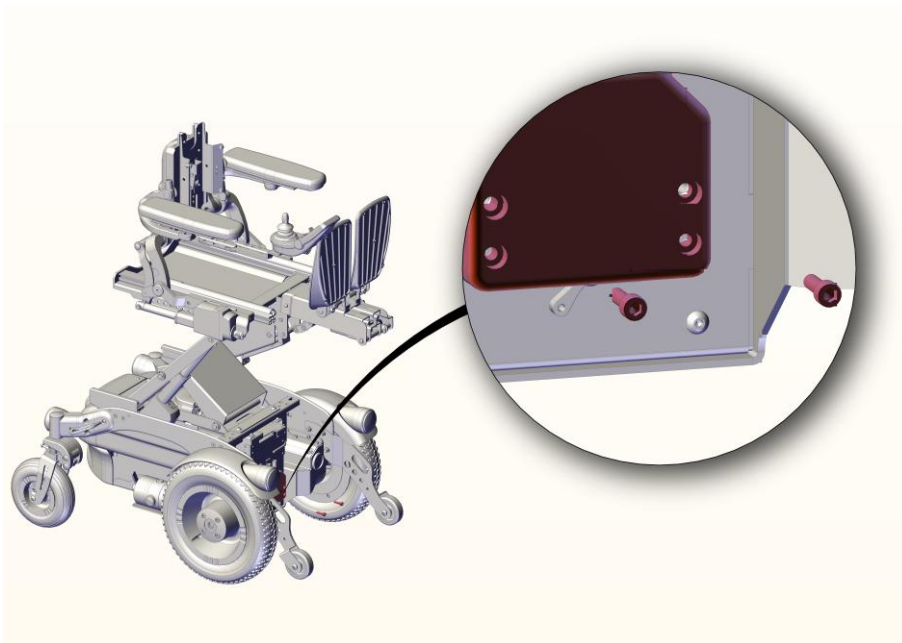

Figure 131

- Remove the cover A. See section 5.7.3 .
- Unscrew the screws shown in figure.
- Remove the plastic cap.

ALLEN WRENCH



5 mm

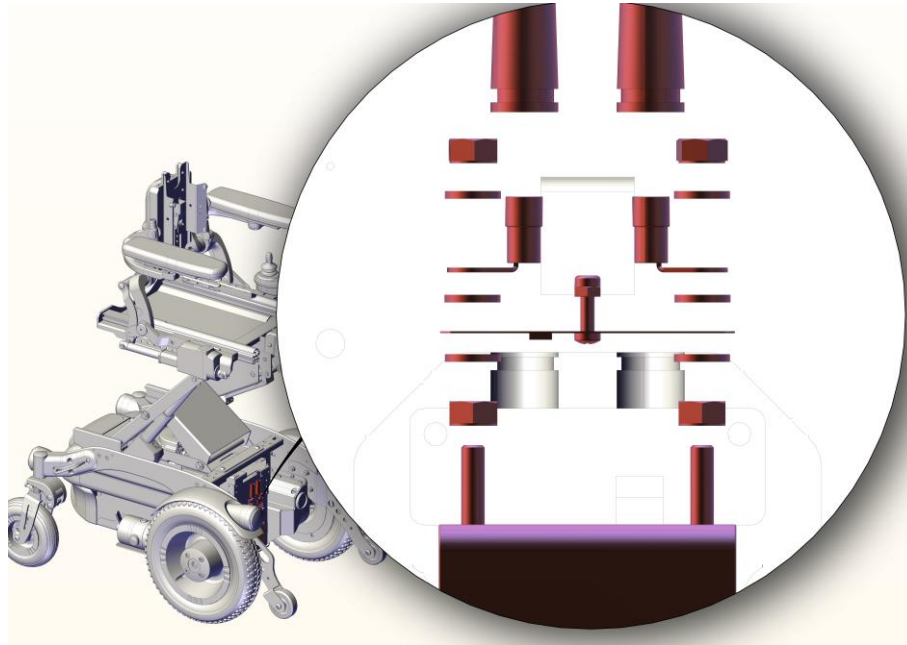

Figure 132

- Unscrew the nuts shown in figure.
- Substitute the main switch. If desired substitute also the fuse PCB.
- Screw again the nuts paying special attention to wires positioning. For more information see 5.4.
- Mount the old plastic cap following instructions in reverse order.
- Mount again the cover A. See section 5.7.3 .

**OPEN-END
WRENCH**

10 mm



**OPEN-END
WRENCH**

5.5 mm

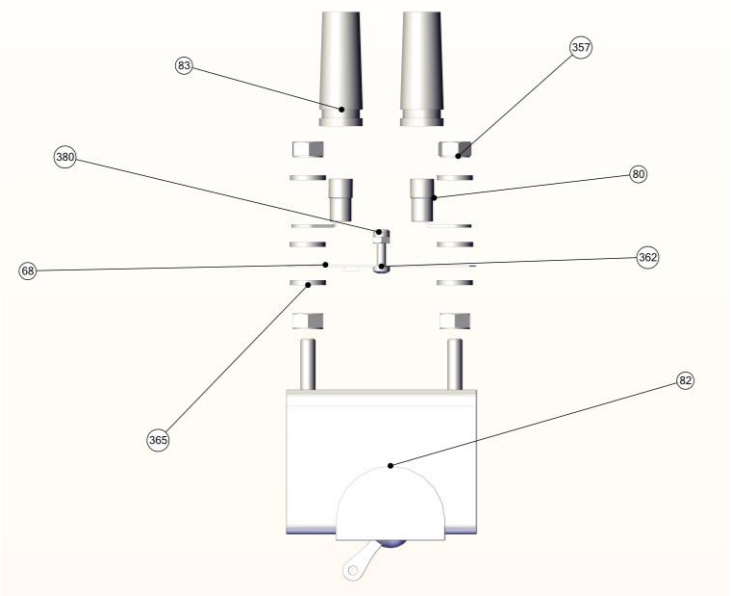

Code	Description	Type of operation	Notes
R042-0180	Main switch	B	
R042-0181	lever for main switch	A	
R042-0182	Fuse PCB	B	

	Code	ID	Quantity
	 <p>Figure 133</p>	R042-0180	83
R042-0180		357	4
R042-0180		365	6
R042-0180		82	1
R042-0181		82 only lever	1
R042-0182		380	1
R042-0182		362	1
R042-0182		68	1

5.7.7 Standard joystick support



Average needed time:

5 min



Difficulty level:

Easy

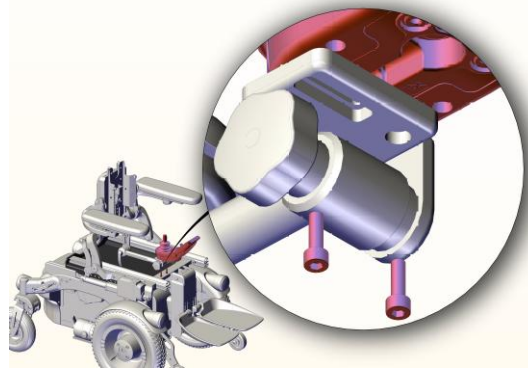

Figure 134

- Unscrew the 2 screws shown in figure.
- Remove the joystick.

ALLEN WRENCH



4 mm

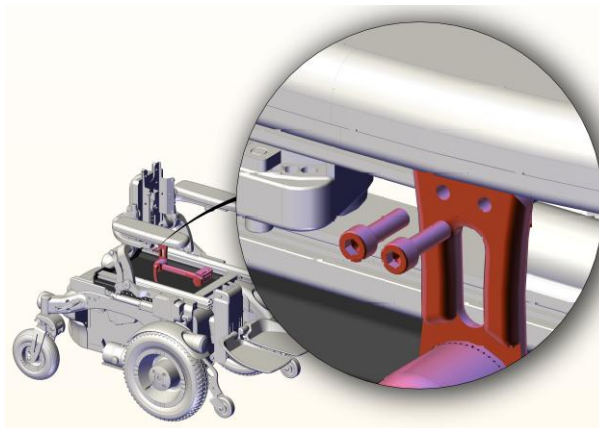

Figure 135

- Unscrew the 2 screws shown in figure. Unscrew the 2 screws shown in figure.
- Substitute the joystick support.
- Mount the old joystick following instructions in reverse order.

ALLEN WRENCH



3 mm

Code	Description	Type of operation	Notes
R042-0190A	Standard joystick support	A	

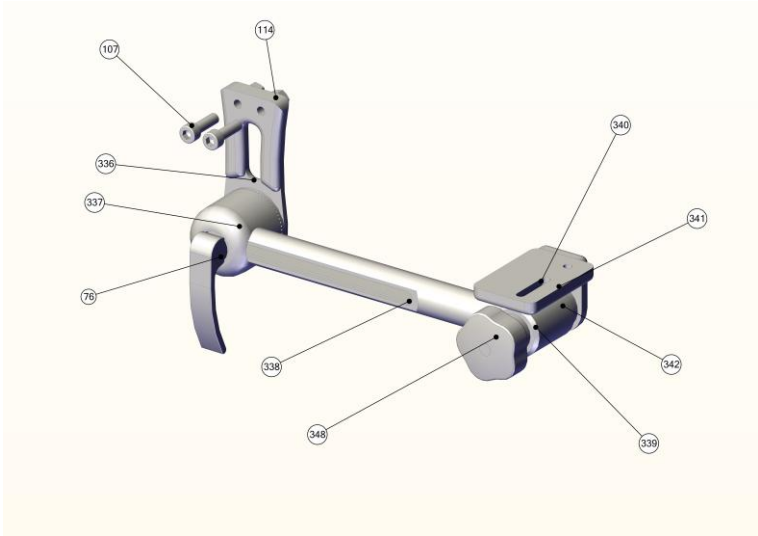
 <p style="text-align: center;">Figure 136</p>	Code	ID	Quantity
	R042-0190 A	76	1
	R042-0190 A	107	2
	R042-0190 A	114	2
	R042-0190 A	336	1
	R042-0190 A	337	1
	R042-0190 A	338	1
	R042-0190 A	339	1
	R042-0190 A	340	1
	R042-0190 A	341	1
	R042-0190 A	342	1
R042-0190 A	348	1	

5.7.8 Retractable joystick support



Average needed time:

5 min



Difficulty level:

Easy

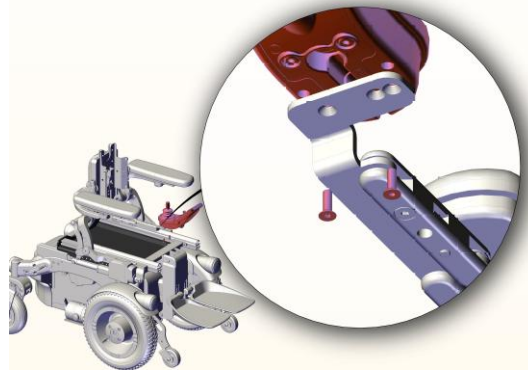

Figure 137

- Unscrew the 2 screws shown in figure.
- Remove the joystick.

ALLEN WRENCH



3 mm

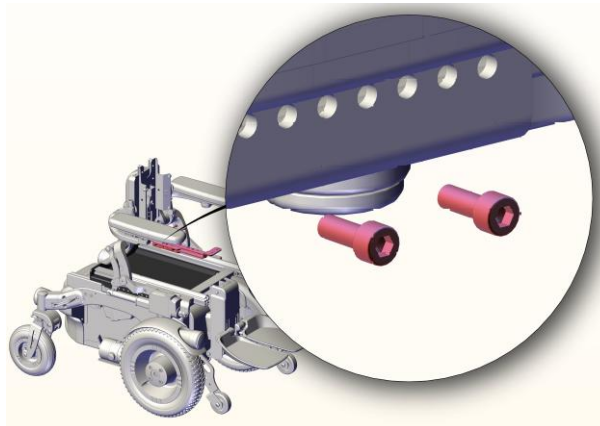

Figure 138

- Unscrew the 2 screws shown in figure.
- Substitute the joystick support.
- Mount the old joystick following instructions in reverse order.

ALLEN WRENCH



3 mm

Code	Description	Type of operation	Notes
R042-0190B	Retractable joystick support	A	

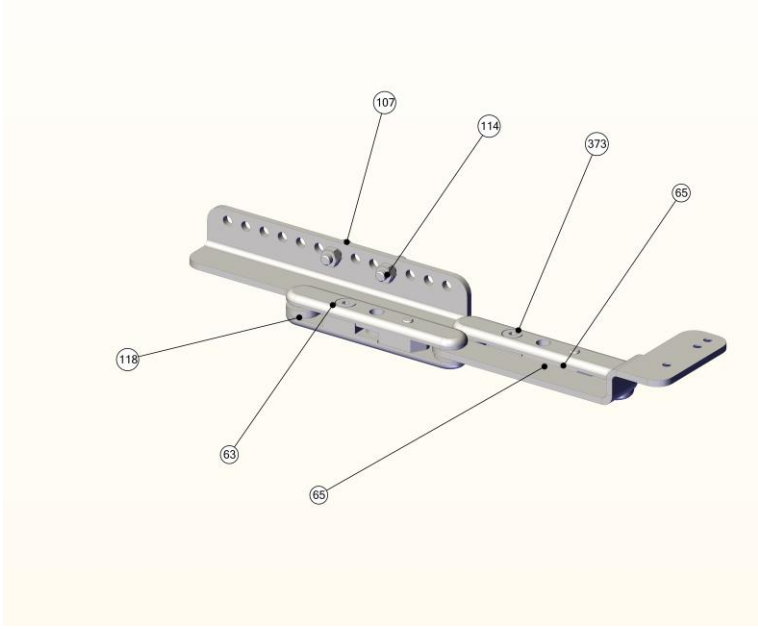
	Code	ID	Quantity	
	 <p>Figure 139</p>	R042-0190B	63	1
R042-0190B		64	1	
R042-0190B		65	4	
R042-0190B		107	2	
R042-0190B		114	2	
R042-0190B		118	8	
R042-0190B		373	4	

5.7.9 Joystick



Average needed time:

5 min



Difficulty level:

Easy

Standard joystick support

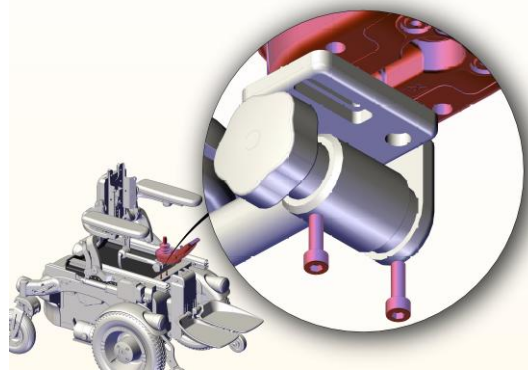

Figure 140

- Unscrew the 2 screws shown in figure.
- Substitute the joystick.

ALLEN WRENCH



4 mm

Retractable joystick support

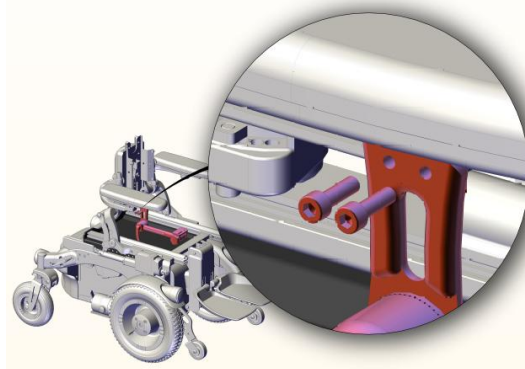

Figure 141

- Unscrew the 2 screws shown in figure. Unscrew the 2 screws shown in figure.
- Substitute the joystick support.

ALLEN WRENCH



3 mm

Code	Description	Type of operation	Notes
R042-0200	Standard joystick support Joystick	A	

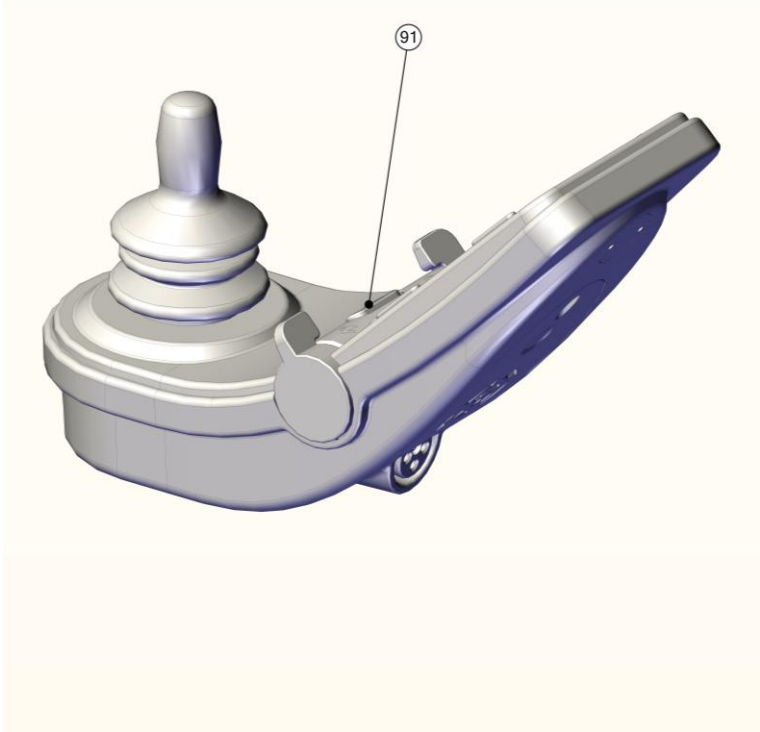
 <p style="text-align: center;">Figure 142</p>	Code	ID	Quantity
	R042-0200	91	1

5.7.10 Power module



Average needed time:

20 min



Difficulty level:

Easy



In order to safely perform this operation, it is necessary to activate some powered seat functions. In case of problems with the seating system, please contact the manufacturer.

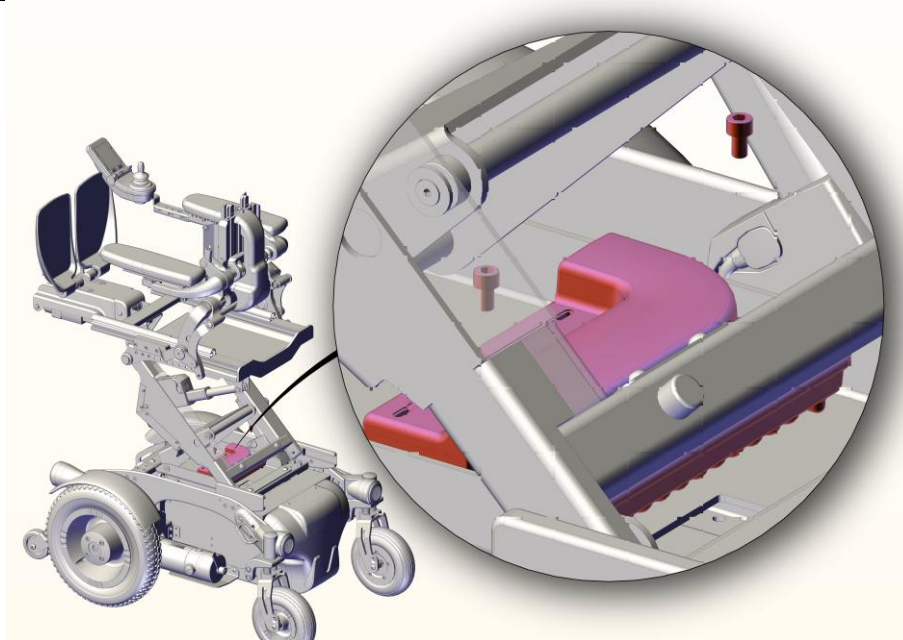

Figure 143

- Lift the seat.
- Unscrew the screws shown in figure.
- Unplug cables. For more information see section 5.4.
- Substitute the power module.
- Plug again cables. For more information see section 5.4.
- Screw again screws

ALLEN WRENCH



5 mm

Code	Description	Type of operation	Notes
R042-0210	Power module	B	

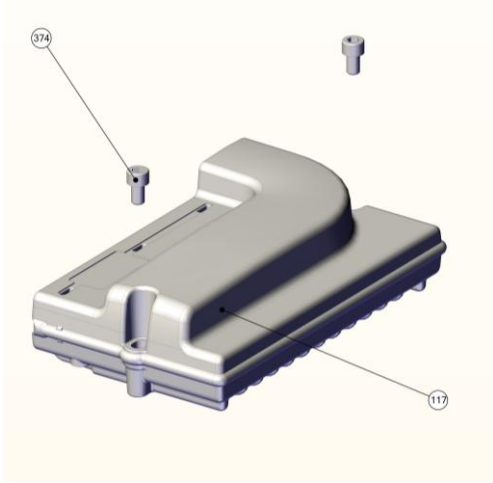
 <p>Figure 144</p>	<table border="1"> <thead> <tr> <th>Code</th> <th>ID</th> <th>Quantity</th> </tr> </thead> <tbody> <tr> <td>R042-0210</td> <td>117</td> <td>1</td> </tr> <tr> <td>R042-0210</td> <td>374</td> <td>2</td> </tr> <tr> <td></td> <td></td> <td></td> </tr> <tr> <td></td> <td></td> <td></td> </tr> <tr> <td></td> <td></td> <td></td> </tr> <tr> <td></td> <td></td> <td></td> </tr> <tr> <td></td> <td></td> <td></td> </tr> <tr> <td></td> <td></td> <td></td> </tr> <tr> <td></td> <td></td> <td></td> </tr> <tr> <td></td> <td></td> <td></td> </tr> </tbody> </table>	Code	ID	Quantity	R042-0210	117	1	R042-0210	374	2																								
	Code	ID	Quantity																															
	R042-0210	117	1																															
	R042-0210	374	2																															



WARNING

When performing this operation, it is necessary to reprogram the wheelchair. For more information see section 2.1.2 .

5.7.11 Seating module



Average needed time:
10 min



Difficulty level:
Easy



Figure 145

- Remove the cover B. See section Unscrew the 2 screws shown in figure. 5.7.4 .
- Unscrew the screws shown in figure.
- Unplug the connector shown in figure. For more information see section 5.4.

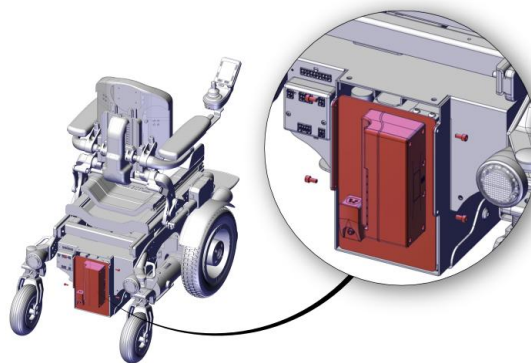

Figure 146

- Unscrew the 4 screws shown in figure.
- Remove the metalsheet with mounted modules. **It is not necessary to unplug any wires.**

ALLEN WRENCH



3 mm

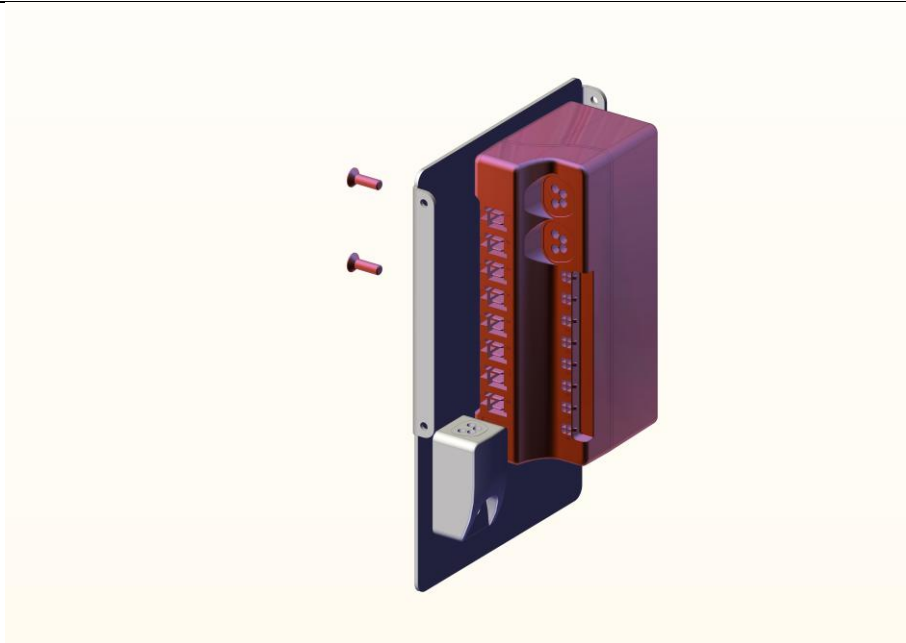

Figure 147

- Unscrew the screws shown in figure.
- Substitute the seating module.
- Mount the new module following instructions in reverse order.

ALLEN WRENCH



3 mm

Code	Description	Type of operation	Notes
R042-0220	Seating module	B	

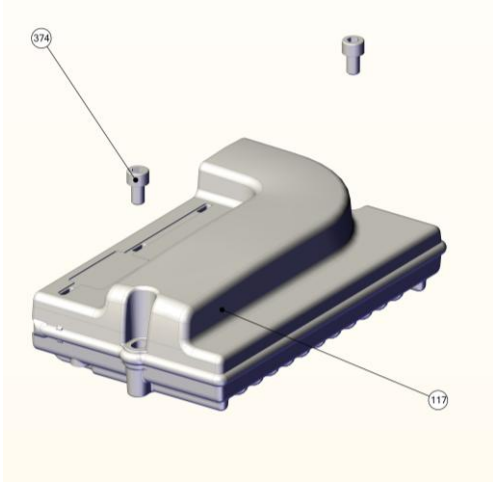
 <p>Figure 148</p>	<table border="1"> <thead> <tr> <th>Code</th> <th>ID</th> <th>Quantity</th> </tr> </thead> <tbody> <tr> <td>R042-0220</td> <td>89</td> <td>1</td> </tr> <tr> <td>R042-0220</td> <td>373</td> <td>2</td> </tr> <tr> <td>R042-0220</td> <td>ND cable</td> <td>1</td> </tr> <tr> <td></td> <td></td> <td></td> </tr> <tr> <td></td> <td></td> <td></td> </tr> <tr> <td></td> <td></td> <td></td> </tr> <tr> <td></td> <td></td> <td></td> </tr> <tr> <td></td> <td></td> <td></td> </tr> <tr> <td></td> <td></td> <td></td> </tr> </tbody> </table>	Code	ID	Quantity	R042-0220	89	1	R042-0220	373	2	R042-0220	ND cable	1																		
	Code	ID	Quantity																												
	R042-0220	89	1																												
	R042-0220	373	2																												
	R042-0220	ND cable	1																												



WARNING

When performing this operation, it is necessary to reprogram the wheelchair. For more information see section 2.1.2 .

5.7.12 Castor light kit



Average needed time:

10 min



Difficulty level:

Easy

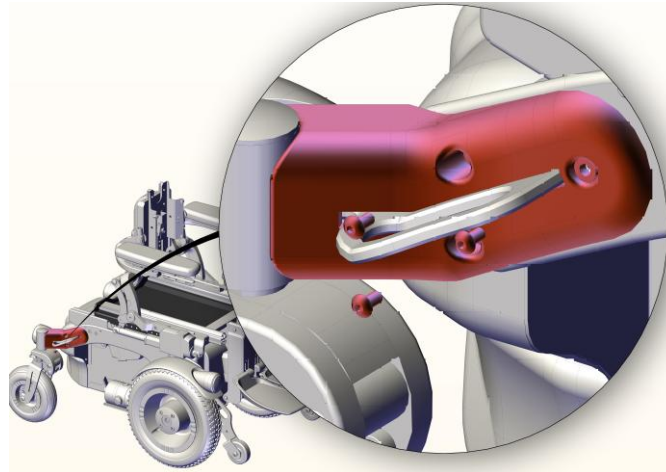

Figure 149

- Unscrew the screws shown in figure.
- If desired substitute the cover.

ALLEN WRENCH



3 mm

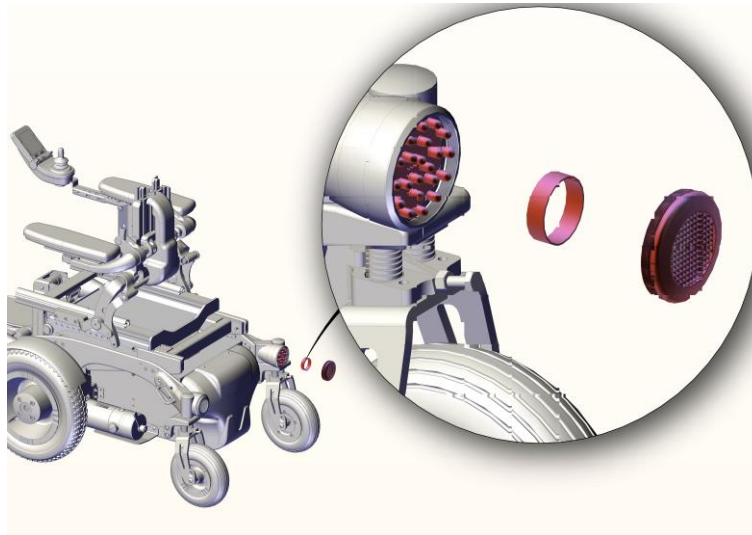

Figure 150

- Unscrew the glass shown in figure.
- Unplug the light.

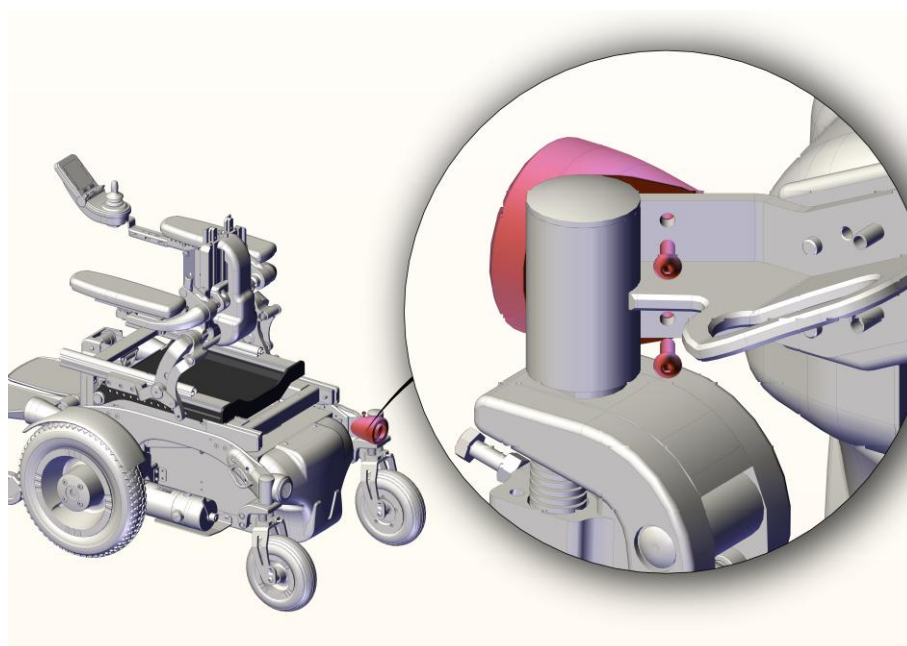

Figure 151

- Unscrew the screw shown in figure.
- Substitute the parts shown in figure.

ALLEN WRENCH



3 mm

Code	Description	Type of operation	Notes
R042-0250	Kit light for castor	A	
R042-0251	Light for castor	A	
R042-0252	Castor cover	A	

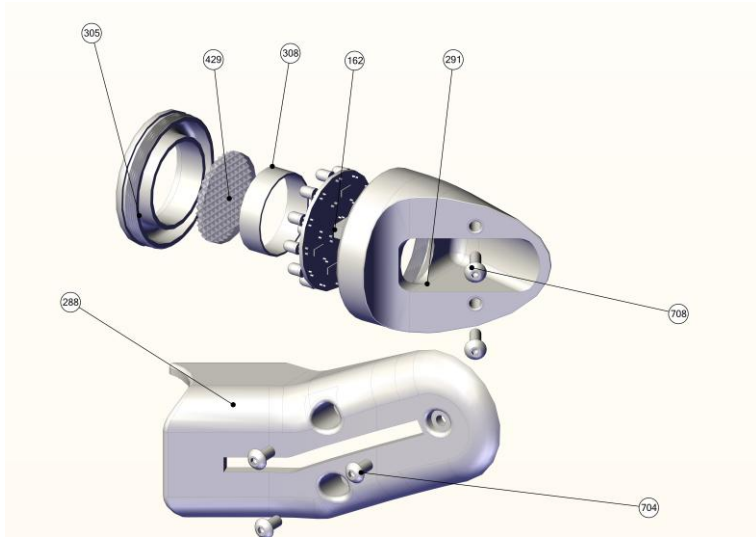

Figure 152

Code	ID	Quantity
R042-0250	162	1
R042-0250	288	1
R042-0250	291	1
R042-0250	305	1
R042-0250	308	1
R042-0250	429	1
R042-0250	704	3
R042-0250	708	2
R042-0521	162	1
R042-0252	308	1

5.7.13 Mudguard light kit



Average needed time:

10 min



Difficulty level:

Easy

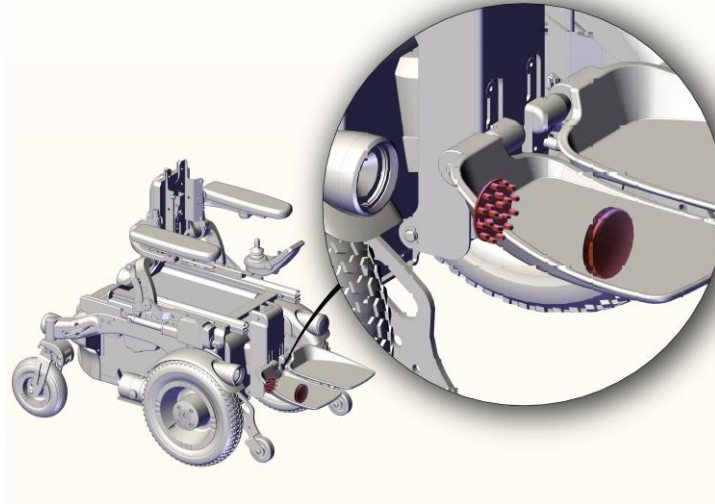

Figure 153

- Unscrew the glass shown in figure.
- Unplug the light.

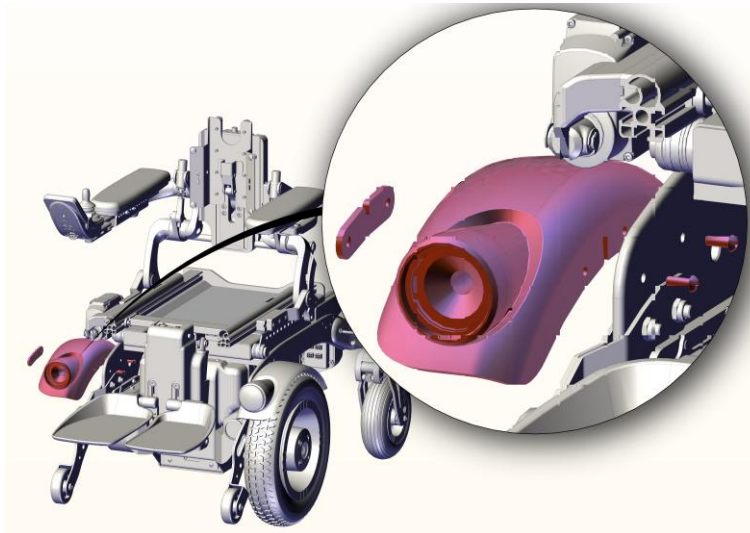

Figure 154

- Unscrew the screw shown in figure.
- Substitute the parts shown in figure.

ALLEN WRENCH



4 mm

Code	Description	Type of operation	Notes
R042-0270B	Mudguard kit RH	A	
R042-0270A	Mudguard kit LH	A	
R042-0271	Light for mudguard	A	

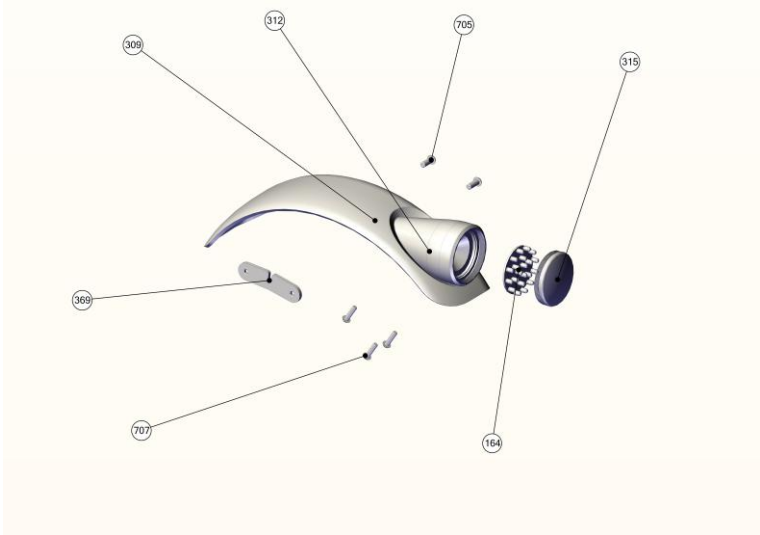
	Code	ID	Quantity	
	 <p>Figure 155</p>	R042-0270	164	1
R042-0270		309	1	
R042-0270		312	1	
R042-0270		315	1	
R042-0270		369	1	
R042-0270		705	2	
R042-0270		707	3	
R042-0271		161	1	

5.7.14 Bumpers for motors



Average needed time:

10 min



Difficulty level:

Easy

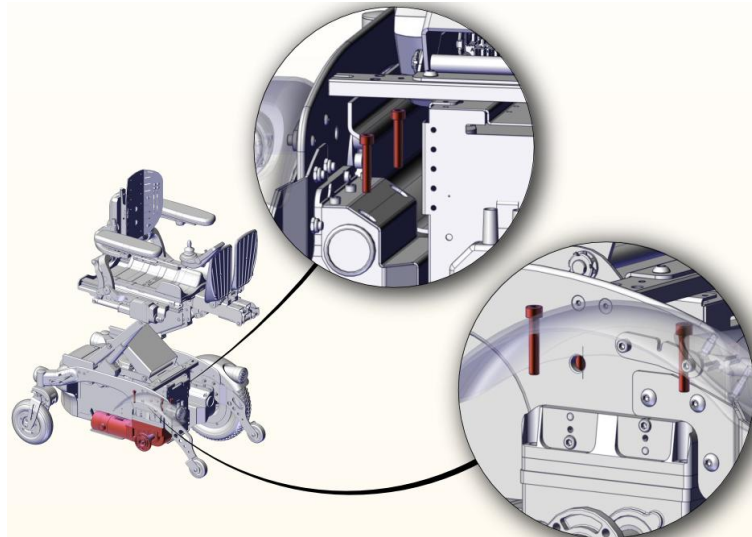

Figure 156

- Unscrew the screws shown in figure.
- Substitute the bumper for motor. Substitute the bumper for motor.
- Repeat operations for both left and right side of the wheelchair.

ALLEN WRENCH



4 mm

Code	Description	Type of operation	Notes
R042-0280	Bumpers for motors	B	

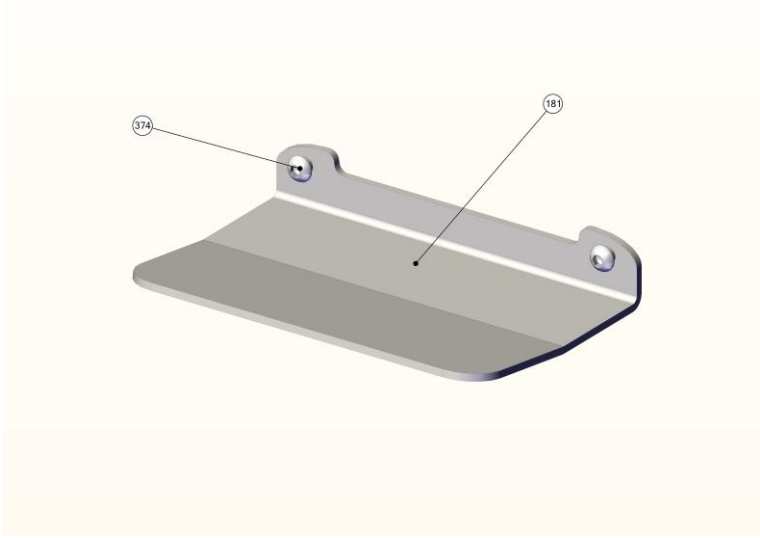
 <p style="text-align: center;">Figure 157</p>	Code	ID	Quantity
	R042-0280	181	2
	R042-0280	374	4
			4
			1
			1

5.7.15 Gyro module



Average needed time:

10 min



Difficulty level:

Easy



Figure 158

- Remove the cover B. See section Unscrew the 2 screws shown in figure. 5.7.4 .
- Unplug the connector shown in figure. For more information see section 5.4.

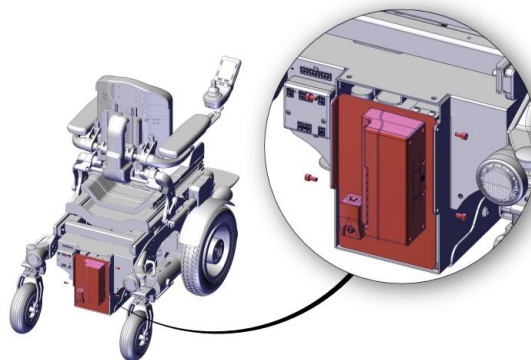

Figure 159

- Unscrew the 4 screws shown in figure.
- Remove the metalsheet with mounted modules. **It is not necessary to unplug any wires.**

ALLEN WRENCH



3 mm

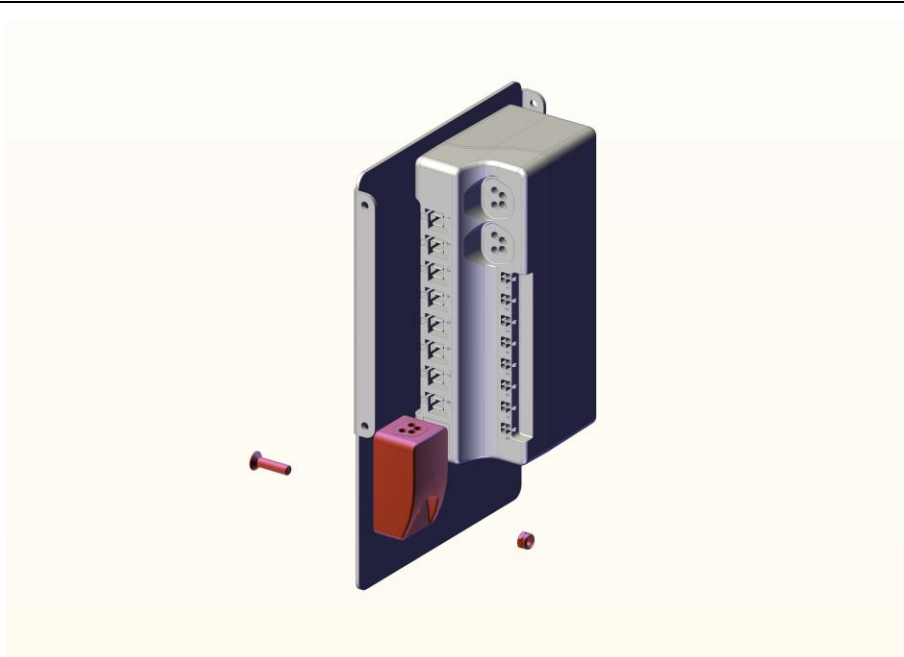

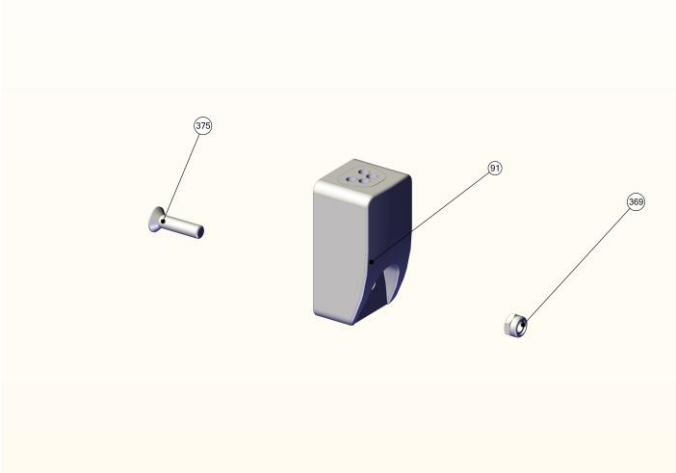

Figure 160

<ul style="list-style-type: none"> • Unscrew the screw shown in figure using a allen wrench while holding the nut behind with a open-end wrench. 	<p>ALLEN WRENCH</p>  <p>3 mm</p>
<ul style="list-style-type: none"> • Substitute the gyro module. • Mount the new module following instructions in reverse order. 	<p>OPEN-END WRENCH</p>  <p>8 mm</p>

Code	Description	Type of operation	Notes
R042-0290	Gyro module	B	

 <p>Figure 161</p>	Code	ID	Quantity	
		R042-0290	91	1
		R042-0290	369	1
		R042-0290	375	1
		R042-0290	ND cable	1



WARNING

When performing this operation, it is necessary to reprogram the wheelchair. For more information see section 2.1.2 ..

5.7.16 Light module



Average needed time:

10 min



Difficulty level:

Easy



In order to safely perform this operation, it is necessary to activate some powered seat functions. In case of problems with the seating system, please contact the manufacturer.

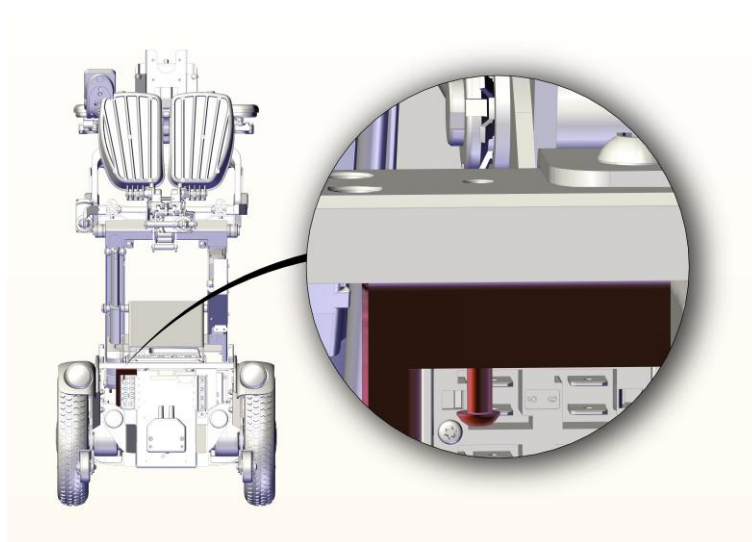

Figure 162

- Lift the seat.
- Remove the cover A. See section 5.7.3 .
- Unscrew the screw shown in figure.

ALLEN WRENCH



2.5 mm

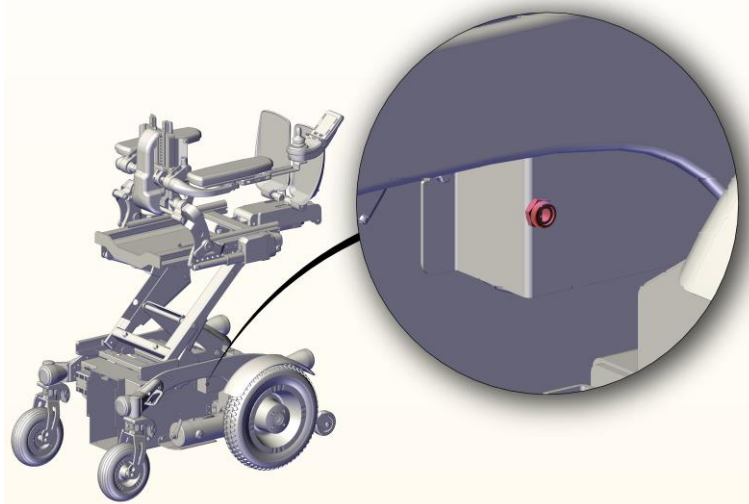

Figure 163

- Remove batteries. See section 4.7.1 .
- Unscrew the nut shown in figure.

**OPEN-END
WRENCH**

10 mm

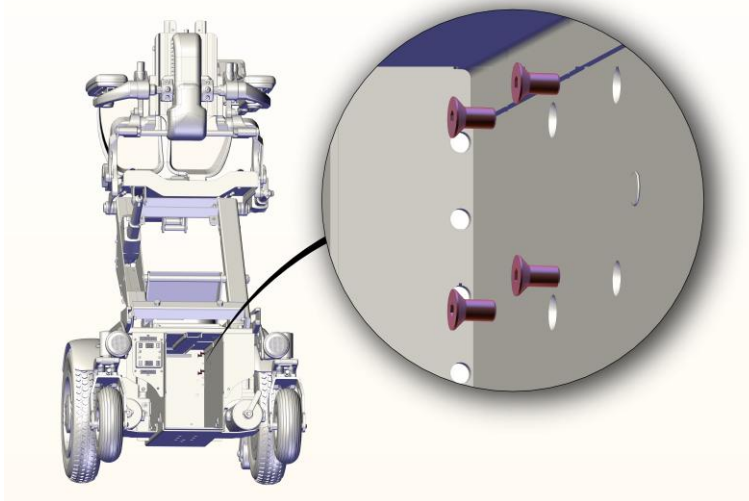

Figure 164

- Inside the battery housing there are 4 screws. Unscrew them to remove the light module.
- Mount the new module following instructions in reverse order.

ALLEN WRENCH

3 mm

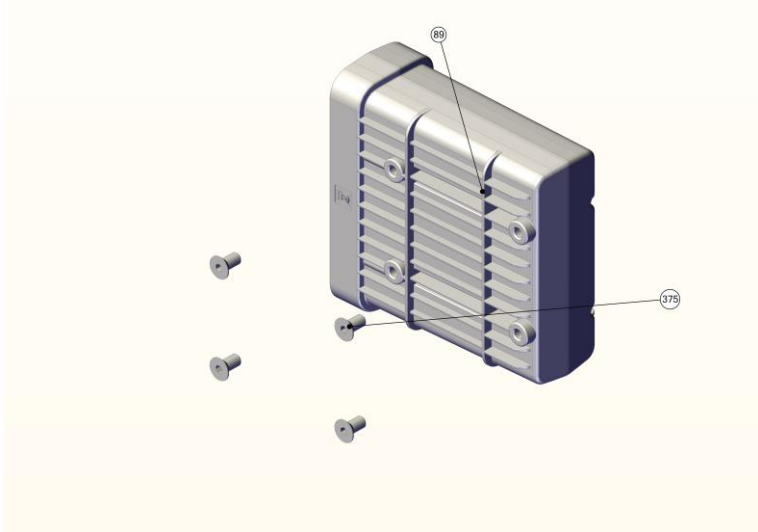

Code	Description	Type of operation	Notes
R042-0300	Light module	B	

	Code	ID	Quantity
	 <p>Figure 165</p>	R042-0300	89
R042-0300		375	4



WARNING

When performing this operation, it is necessary to reprogram the wheelchair. For more information see section 2.1.2 ..

5.7.17 Legrest cover



Average needed time:

5 min



Difficulty level:

Easy

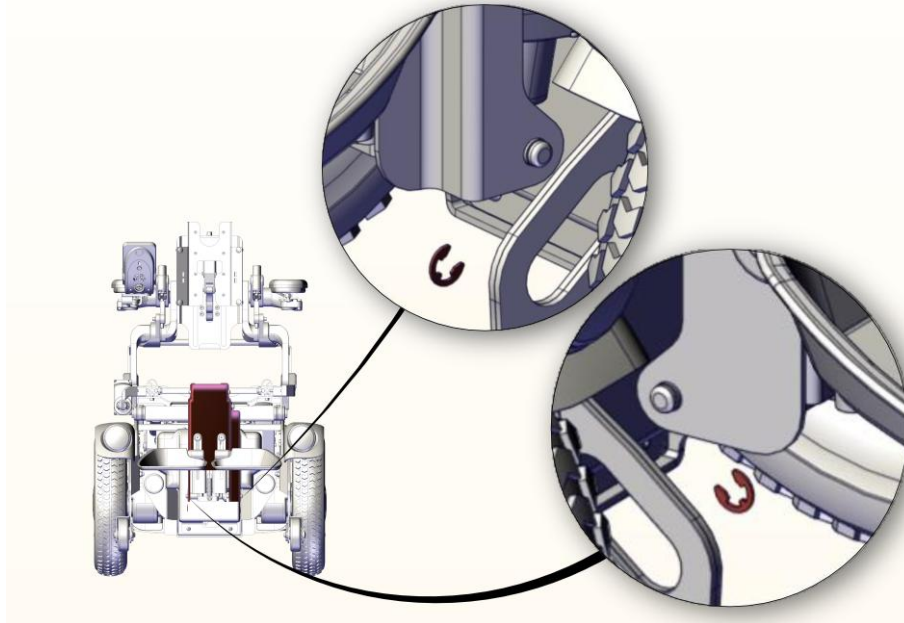

Figure 166

- Remove the seeger shown in figure. Use a screwdriver as a lever.
- Substitute the cover.

SCREWDRIVER

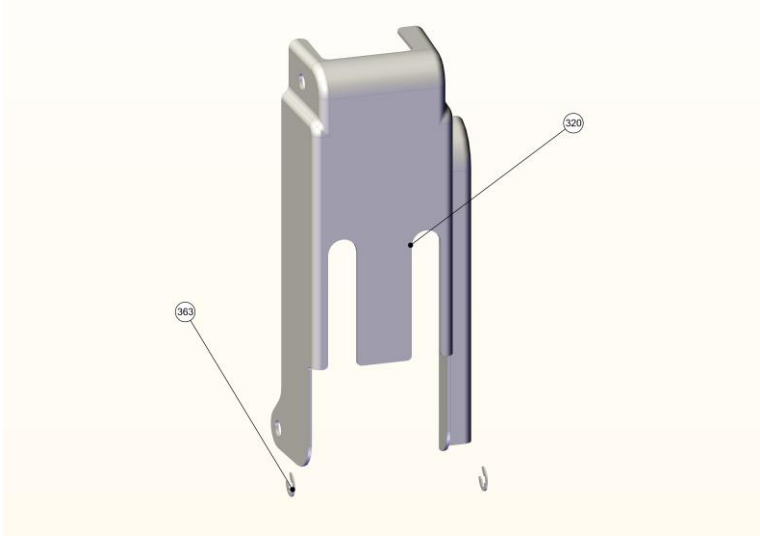

Code	Description	Type of operation	Notes
R042-0311	Legrest cover	A	

	Code	ID	Quantity
	 <p>Figure 167</p>	R042-0311	320
R042-0311		363	2

5.7.18 Legrest actuator



Average needed time:

5 min



Difficulty level:

Easy

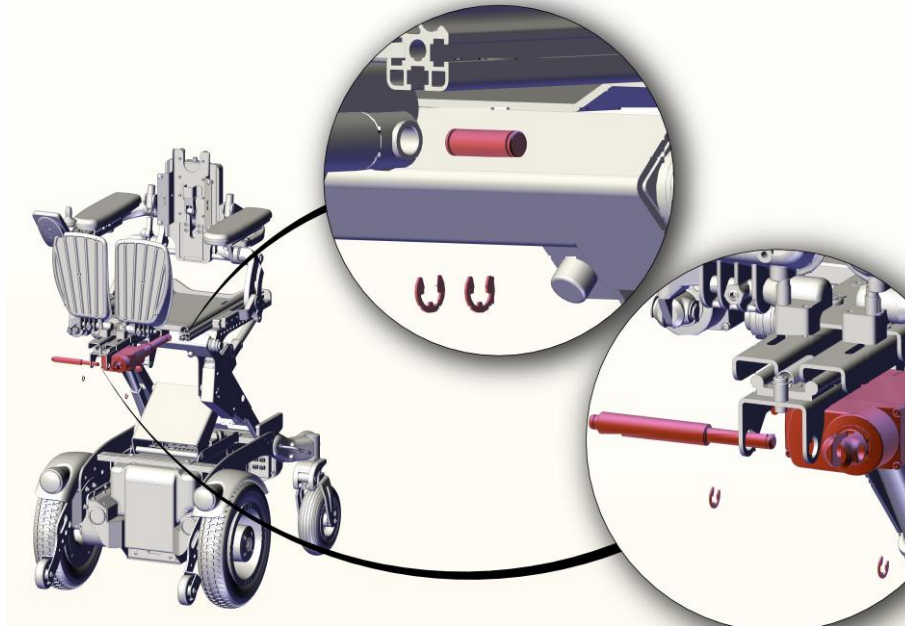

Figure 168

- Remove legrest cover. See section 5.7.17 .
- Remove the seeger shown in figure. Use a screwdriver as a lever.
- Remove axis shown in figure.
- Unplug cable of actuator.
- Substitute the actuator.

SCREWDRIVER

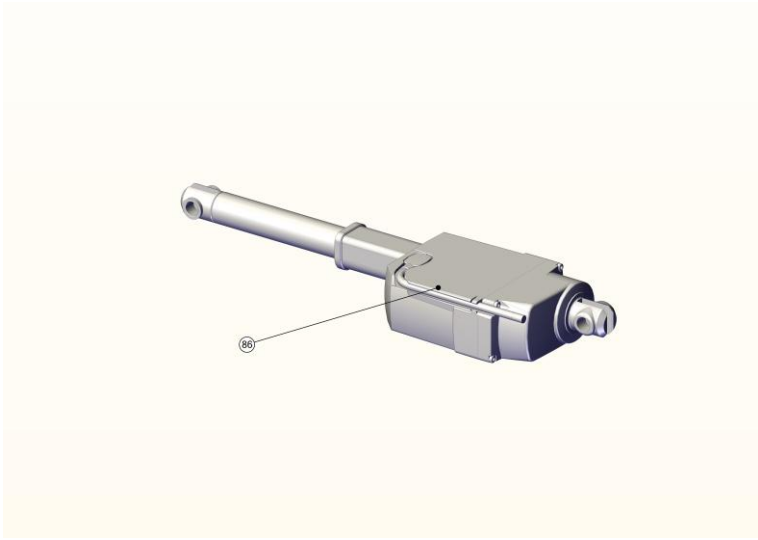

Code	Description	Type of operation	Notes
R042-0313	Legrest actuator	A	

 <p style="text-align: center;">Figure 169</p>	Code	ID	Quantity
	R042-0313	86	1



WARNING

In order to facilitate this operation, it could be needed to move actuator independently from the seating system of the wheelchair.



WARNING

When performing this operation, it is necessary to reprogram the wheelchair. For more information see section 2.1.2 .

5.7.19 Excursion metalsheet for legrest



Average needed time:

10 min



Difficulty level:

Easy

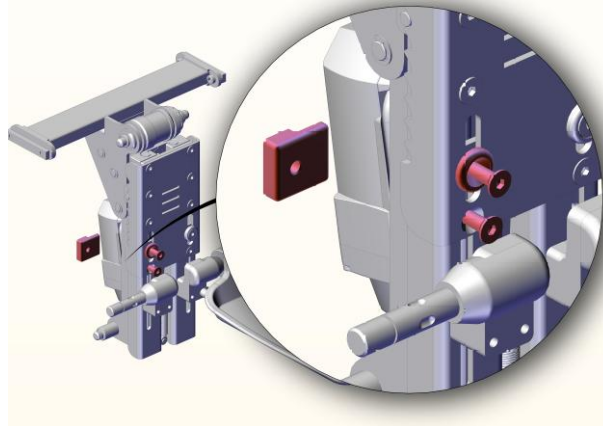

Figure 170

- Remove legrest cover. See section 5.7.17 .
- Remove footplate. See section 5.7.21
- Unscrew the screws shown in figure.

ALLEN WRENCH



4 mm

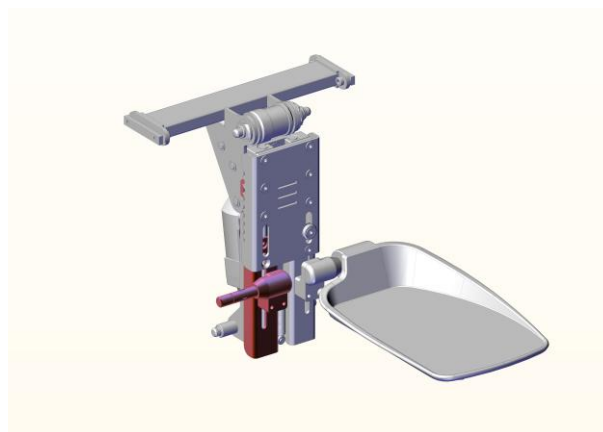
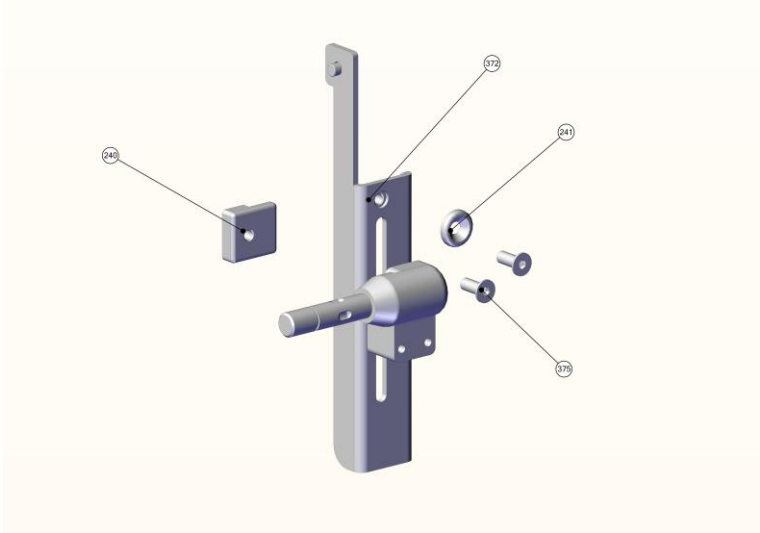

Figure 171

- Substitute parts shown in figure.
- Repeat operations for both left and right side of the wheelchair.

Code	Description	Type of operation	Notes
R042-0314F	Excursion metalsheet for legrest 27-32 cm	B	
R042-0314G	Excursion metalsheet for legrest 30-38 cm	B	
R042-0314H	Excursion metalsheet for legrest 38-46 cm	B	

 <p style="text-align: center;">Figure 172</p>	Code	ID	Quantity
	R042-0314	240	1+1
	R042-0314	241	1+1
	R042-0314	375	2+2
	R042-0314°	372 A	1+1
	R042-0314B	372B	1+1
	R042-0314C	372C	1+1
	R042-0314D	372D	1+1
	R042-0314E	372E	1+1

5.7.20 Spring for legrest



Average needed time:

10 min



Difficulty level:

Easy

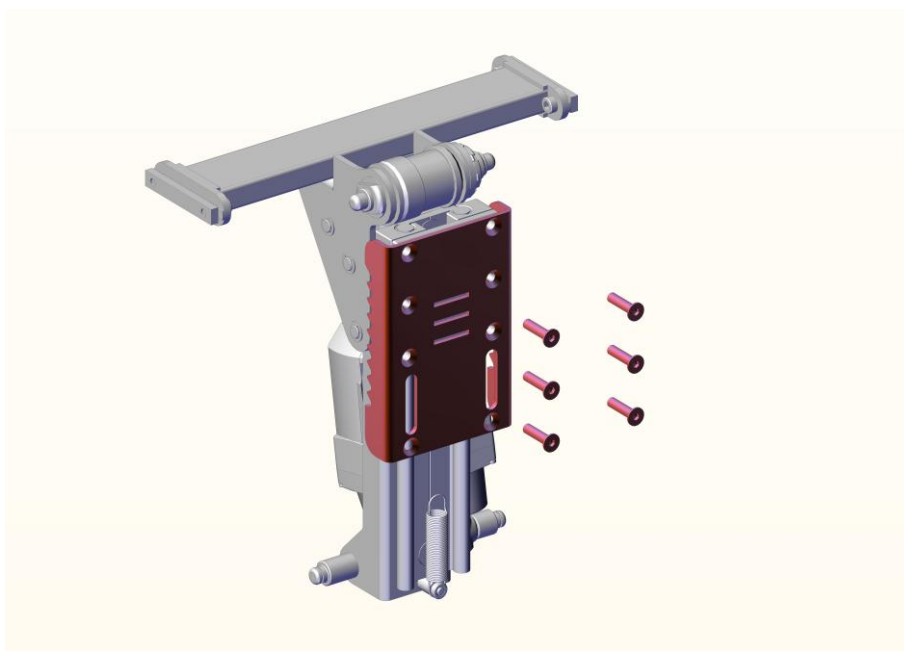

Figure 173

- Remove legrest cover. See section 5.7.17 .
- Remove footplate. See section 5.7.21
- Remove the excursion metalsheet for legrest See section **Errore. L'origine riferimento non è stata trovata..**
- Unscrew the screws shown in figure.
- Remove the metal sheet shown in figure.

ALLEN WRENCH



4 mm

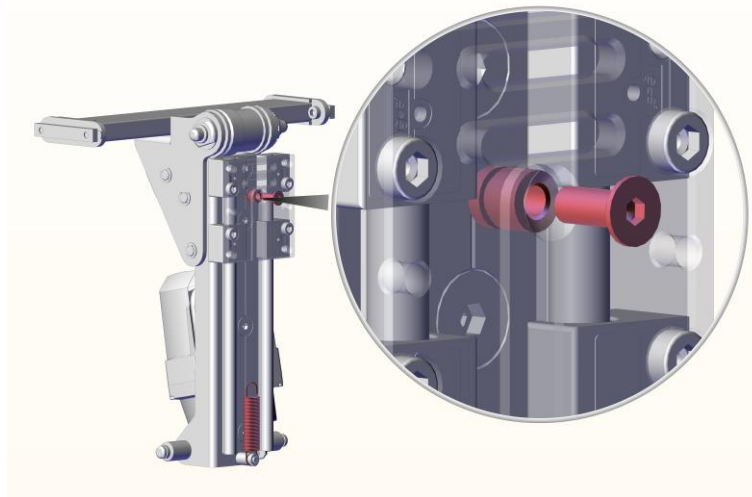

Figure 174

- Unscrew the screw shown in figure.

ALLEN WRENCH



4 mm

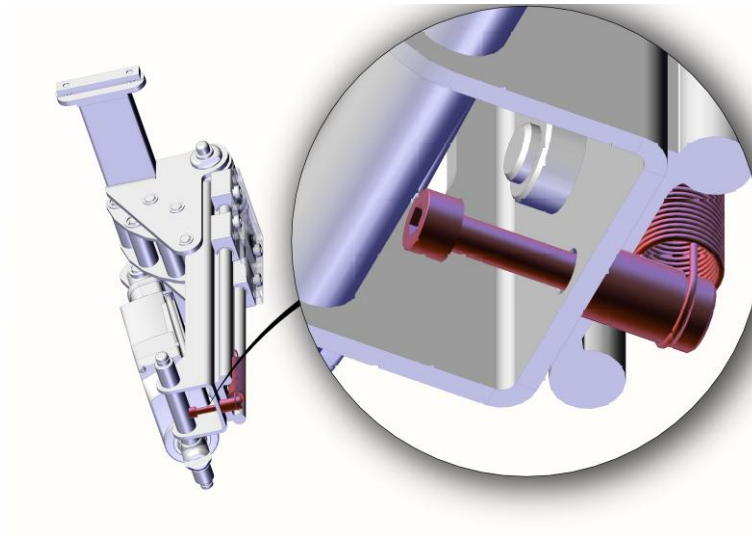

Figure 175

- Unscrew the screw shown in figure.
- Substitute the spring.

ALLEN WRENCH



4 mm

Code	Description	Type of operation	Notes
R042-0315	Legrest spring	B	

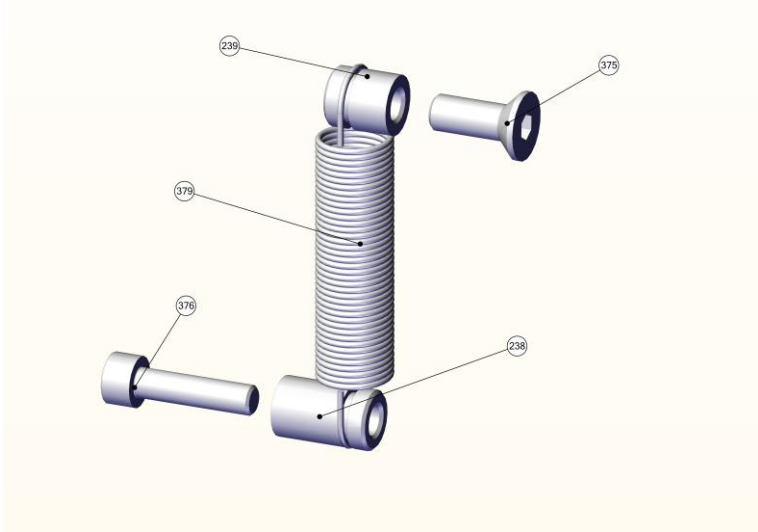
 <p style="text-align: center;">Figure 176</p>	Code	ID	Quantity
	R042-0315	238	1
	R042-0315	239	1
	R042-0315	375	1
	R042-0315	376	1
	R042-0315	379	1

5.7.21 Footplate



Average needed time:

5 min



Difficulty level:

Easy

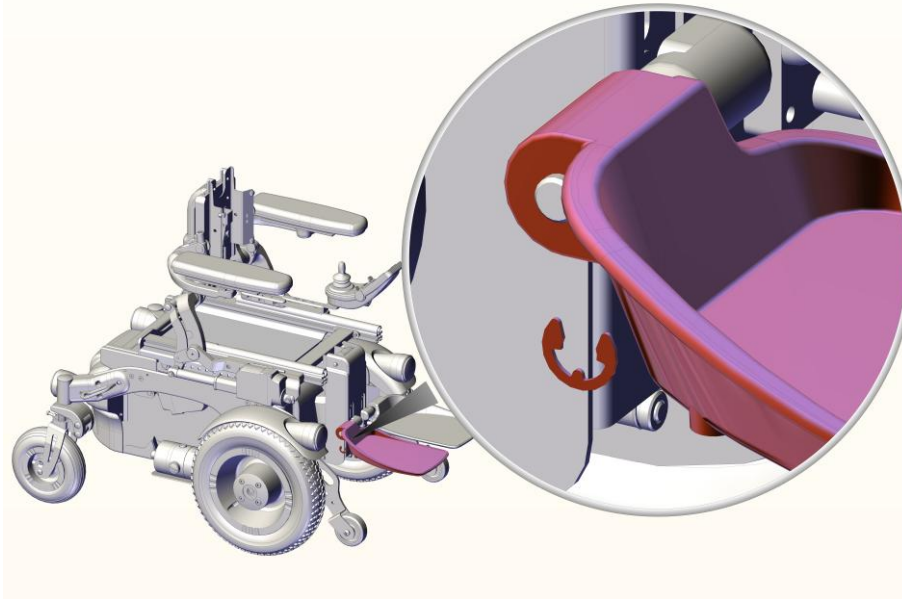

Figure 177

- Remove seeger shown in figure. Use a screwdriver as a lever.
- Substitute footplate.

SCREWDRIVER

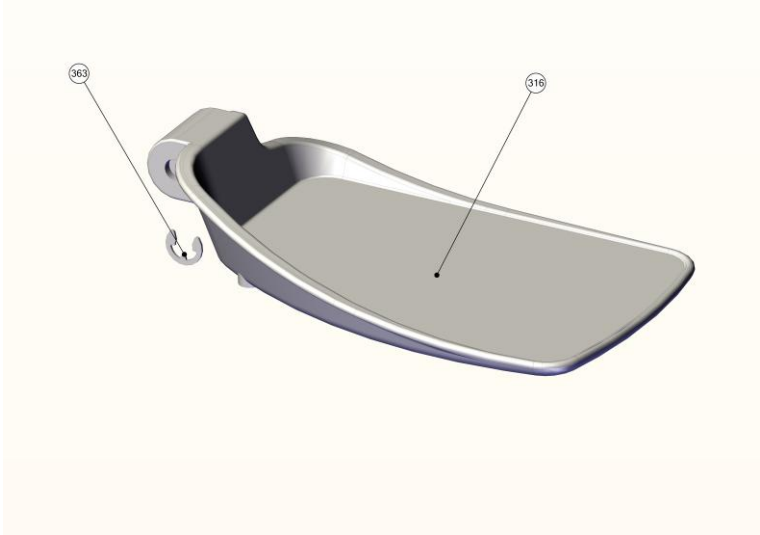

Code	Description	Type of operation	Notes
R042-0320	Footrest	A	

	Code	ID	Quantity
	 <p style="text-align: center;">Figure 178</p>	R042-0320	316
R042-0320		363	2

5.7.22 Tilt actuator



Average needed time:

20 min



Difficulty level:

Easy



In order to safely perform this operation, it is necessary to activate some powered seat functions. In case of problems with the seating system, please contact the manufacturer.



FALL DOWN WARNING

When removing the seeger of actuator, the seating system is free to fall down. Its weight is more than 10 kg. Please pay special attention and adopt each opportune precaution to avoid this fall.



WARNING

When performing this operation, it is necessary to reprogram the wheelchair. For more information see section 2.1.2 .



WARNING

In order to facilitate this operation, it could be needed to move actuator independently from the seating system of the wheelchair.

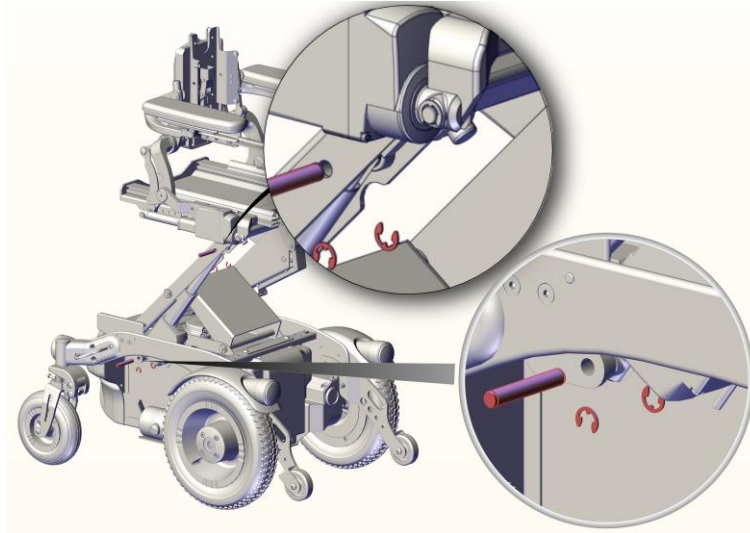

Figure 179

- Lift the seat.
- Remove seeger shown in figure.
- Remove axis shown in figure.
- Unplug the actuator.
- Substitute the actuator

SCREWDRIVER



Code	Description	Type of operation	Notes
R042-0330	Tilt actuator	B	

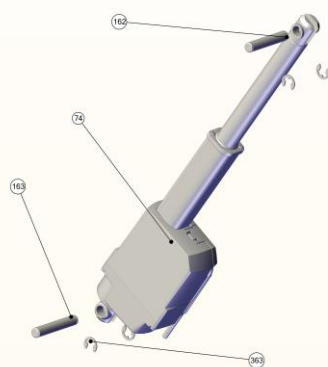

Figure 180

Code	ID	Quantity
R042-0330	74	1
R042-0330	162	1
R042-0330	163	1
R042-0330	363	4

5.7.23 Lift actuator



Average needed time:

20 min



Difficulty level:

Easy



In order to safely perform this operation, it is necessary to activate some powered seat functions. In case of problems with the seating system, please contact the manufacturer.

FALL DOWN WARNING



When removing the seeger of actuator, the seating system is free to fall down. Its weight is more than 10 kg. Please pay special attention and adopt each opportune precaution to avoid this fall.



WARNING

When performing this operation, it is necessary to reprogram the wheelchair. For more information see section 2.1.2 .



WARNING

In order to facilitate this operation, it could be needed to move actuator independently from the seating system of the wheelchair.

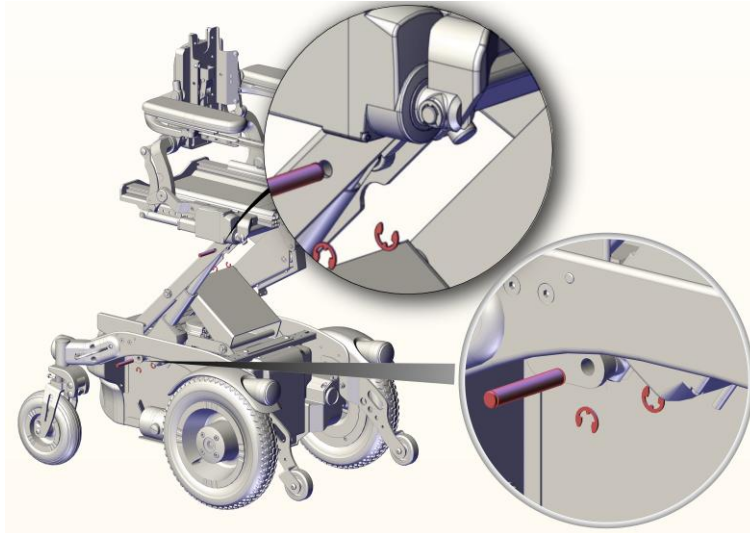

Figure 181

- Lift the seat.
- Remove seeger shown in figure.
- Remove axis shown in figure.
- Unplug the actuator.
- Substitute the actuator.

SCREWDRIVER



Code	Description	Type of operation	Notes
R042-0340	Tilt actuator	B	

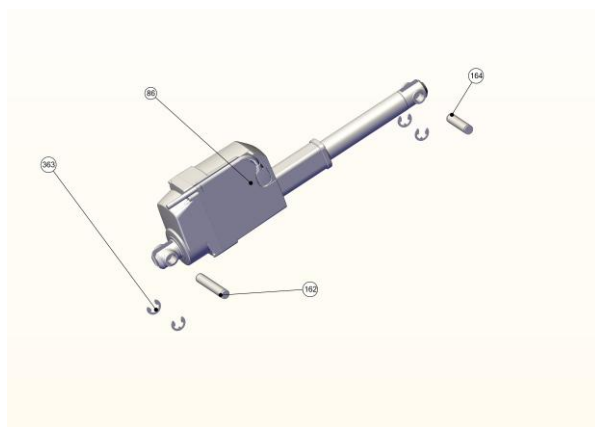

Figure 182

Code	ID	Quantity
R042-0340	86	1
R042-0340	162	1
R042-0340	164	1
R042-0340	363	4

5.7.24 Backrest actuator



Average needed time:

5 min



Difficulty level:

Easy



WARNING

When performing this operation, it is necessary to reprogram the wheelchair. For more information see section 2.1.2 ..

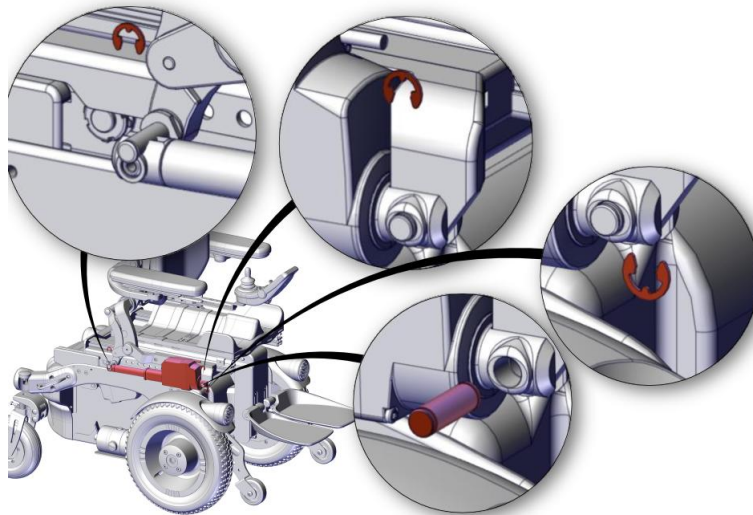
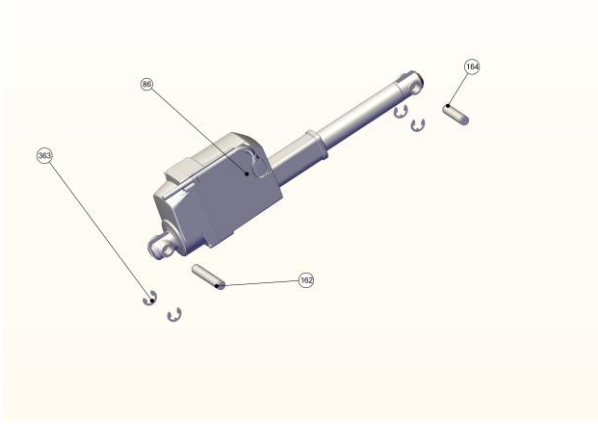

Figure 183

- Remove the 3 Seegers shown in figure. Use a screwdriver as a lever.
- Remove the axis shown in figure.
- Unplug the actuator.
- Substitute the actuator.



Code	Description	Type of operation	Notes
R042-0360	Backrest actuator	A	

 <p style="text-align: center;">Figure 184</p>	Code	ID	Quantity
	R042-0360	87	1
	R042-0360	233	1
	R042-0360	363	3

5.7.25 Backrest cover



Average needed time:

<5 min



Difficulty level:

Easy

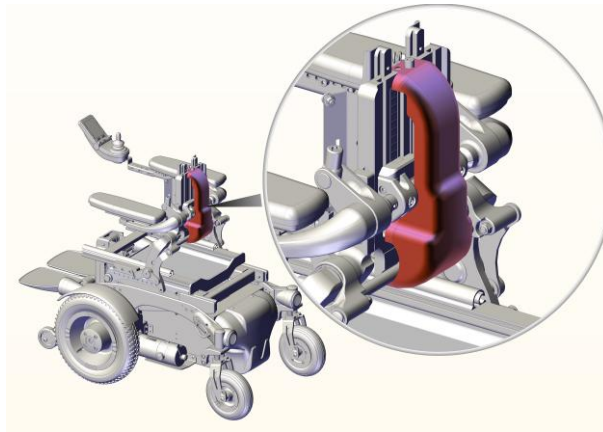

Figure 185

- Substitute the cover shown in figure.

Code	Description	Type of operation	Notes
R042-0371	Backrest cover	A	

<p>Figure 186</p>	Code	ID	Quantity
	R042-0371	273	1

5.7.26 Ruler for armrest adjustment



Average needed time:

10 min



Difficulty level:

Easy

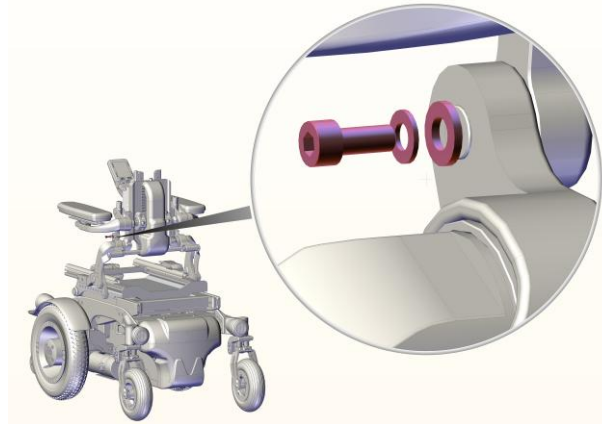

Figure 187

- Unscrew the screw shown in figure.

ALLEN WRENCH



4 mm

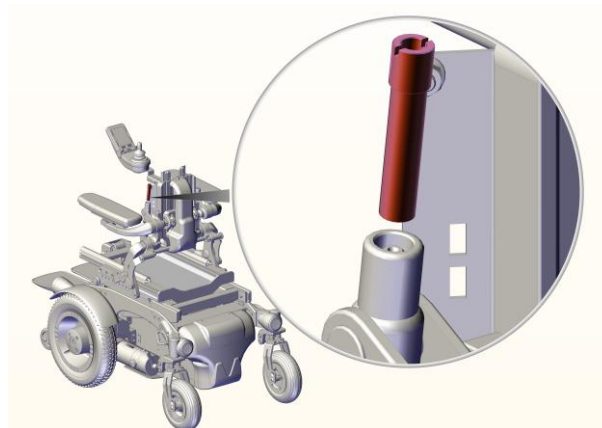

Figure 188

- Unscrew the part shown in figure.

SCREWDRIVER



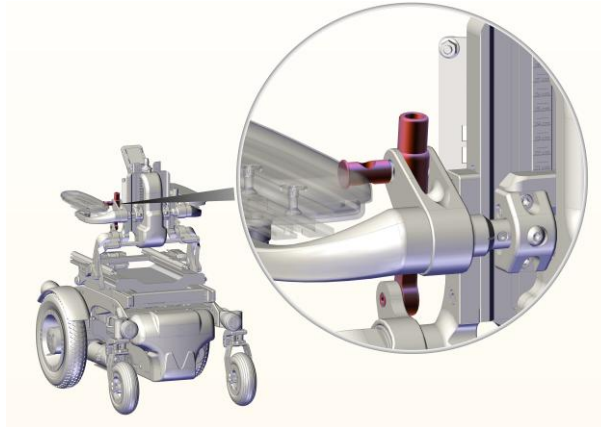

Figure 189

- Substitute parts shown in figure.

Code	Description	Type of operation	Notes
R042-0372	Ruler for armrest adjustment	B	

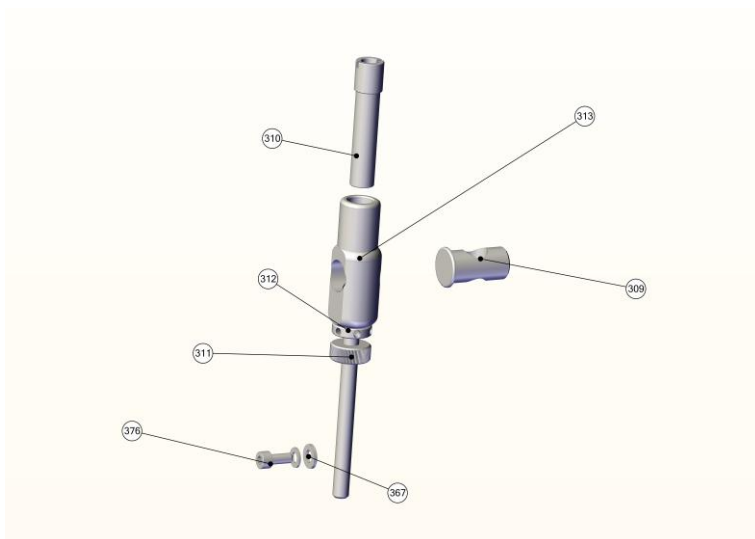

Figure 190

Code	ID	Quantity
R042-0372	309	1
R042-0372	310	1
R042-0372	311	1
R042-0372	312	1
R042-0372	313	1
R042-0372	314	1
R042-0372	367	2
R042-0372	376	1

5.7.27 Armrest joint



Average needed time:

10 min



Difficulty level:

Easy

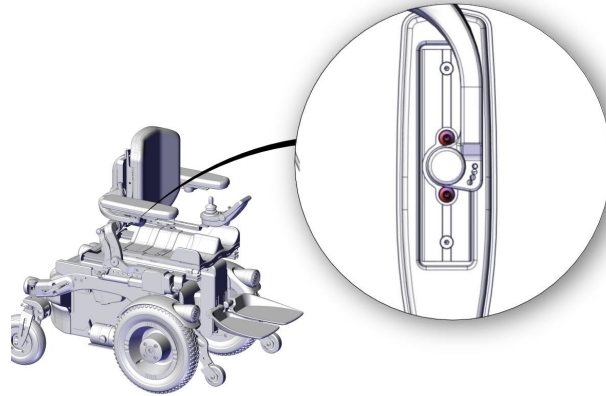

Figure 191

- Loosen the 2 screws shown in figure.
- Substitute the armrest.

ALLEN WRENCH



5 mm

Code	Description	Type of operation	Notes
R042-0380	Armrest	A	

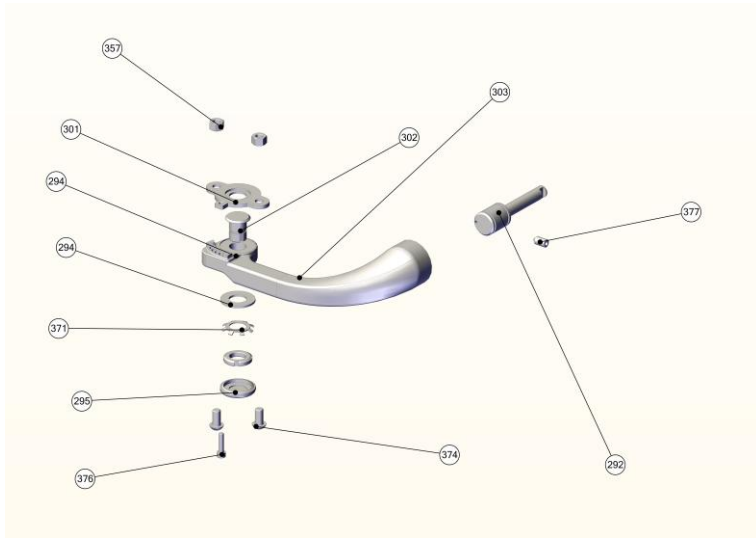

Figure 192

Code	ID	Quantity
R042-0373	292	1
R042-0372	294	2
R042-0372	295	1
R042-0372	301	1
R042-0372	302	1
R042-0372	303	1
R042-0372	355	1
R042-0372	357	2
R042-0372	371	1
R042-0372	374	2
R042-0372	376	1
R042-0372	377	1

5.7.28 Armrest



**Average needed
time:**

5 min



Difficulty level:

Easy

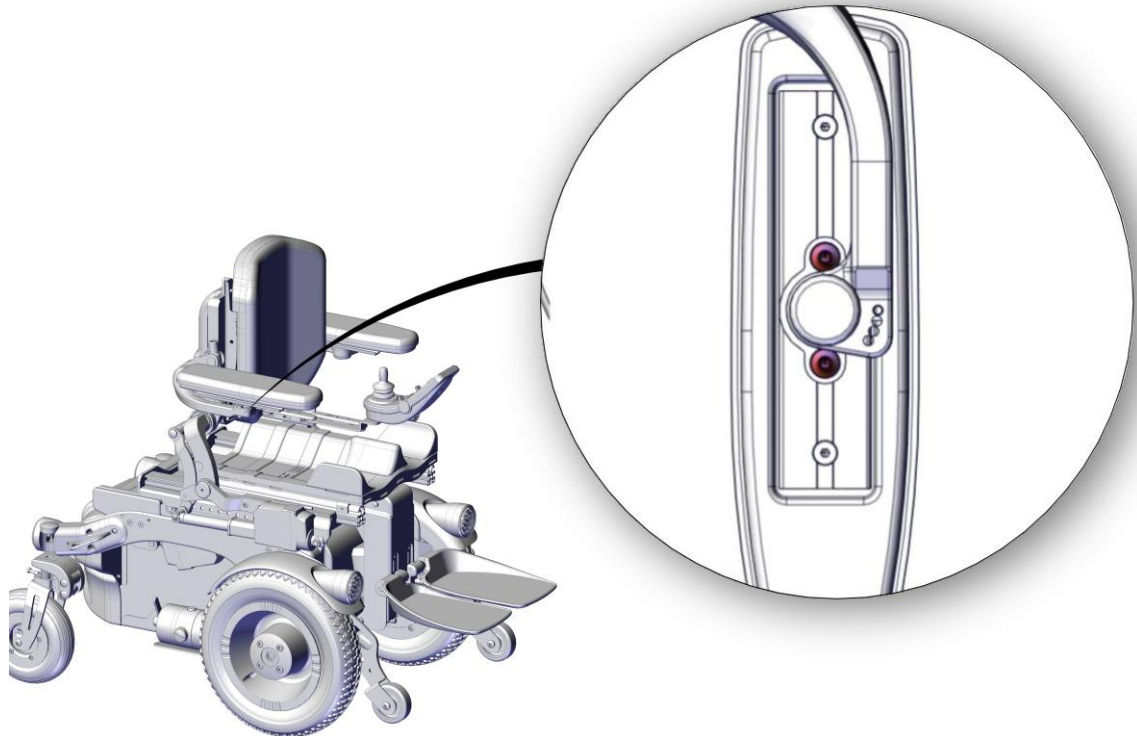

Figure 193

- Loosen the 2 screws shown in figure.
- Remove the armrest.

ALLEN WRENCH



5 mm

6 SPECIFICATIONS

Maximum safety slope (uphill, downhill, lateral)	6°
Weight of the wheelchair	MAX 125 kg
Expected lifetime [years]	10
Class [EN 12184]	B
Range [ISO 7176-4]	>=25 km
	The distance will be reduced if the wheelchair is used frequently on slopes, rough ground or to climb kerbs.
Recommended tire pressure [kPa]	Traction wheels: 280 kPa; Castors: 250 kPa.
Standard compliance	ISO 14971: 2007 EN 12184 : 2009 ISO 7176-8

Intended use	The Evo3 wheelchair is intended to be used by those groups of users with temporary or permanent mobility difficulties confined to a sitting position who need to move in mostly internal environments.
--------------	--

WARNING



It is prohibited to use the product or its parts for any purpose other than that indicated. The manufacturer disclaims any responsibility for damages caused by improper use of aids.

It is possible to use the wheelchair when the temperature is between -10 °C and +40 °C.

It is possible to store the wheelchair in a place with a temperature between -20 °C and +45 °C.

6.1 Maximum user weight

Seat width	MAX
30 cm	50 kg
34 cm	80 kg
38 cm	80 kg
42 cm	80 kg

Table 24

6.2 Other provided information

Manufacturer	Neatech.it srl
Address	via A. de Curtis 4/A – 80040 – Cercola (NA) - Italy
Model	S042 – Evo3

Description	Value
Overall length with legrest	110 cm
Overall width	56.0 cm
Folded length	N.A.
Folded width	N.A.
Folded height	N.A.
Total mass (the weight may change significantly according to the configuration of the wheelchair)	MAX 125 kg
Dynamic stability	6°
Static stability downhill	9°
Static stability uphill	9°
Static stability sideways	9°
Seat plane angle	45°
Effective seat depth	MIN: 30.0 cm MAX: 52.0 cm
Effective seat width	MIN: 30.0 cm MAX: 42.0 cm
Seat surface height at front edge	MIN: 46.0 cm MAX: 48.0 cm
Backrest angle	MIN: 90° MAX: 170°
Backrest height	MIN: 43.0 cm MAX: 63.0 cm
Footrest to seat distance	MIN: 27.0 cm MAX: 48.0 cm
Armrest to seat distance	MIN: 20.0 cm MAX: 30.0 cm
Minimum turning radius [ISO 7176-5]	75.0 cm
Turn around distance [ISO 7176-5]	130 cm

6.3 Dimensions

6.3.1 - Version with biomechanical movements

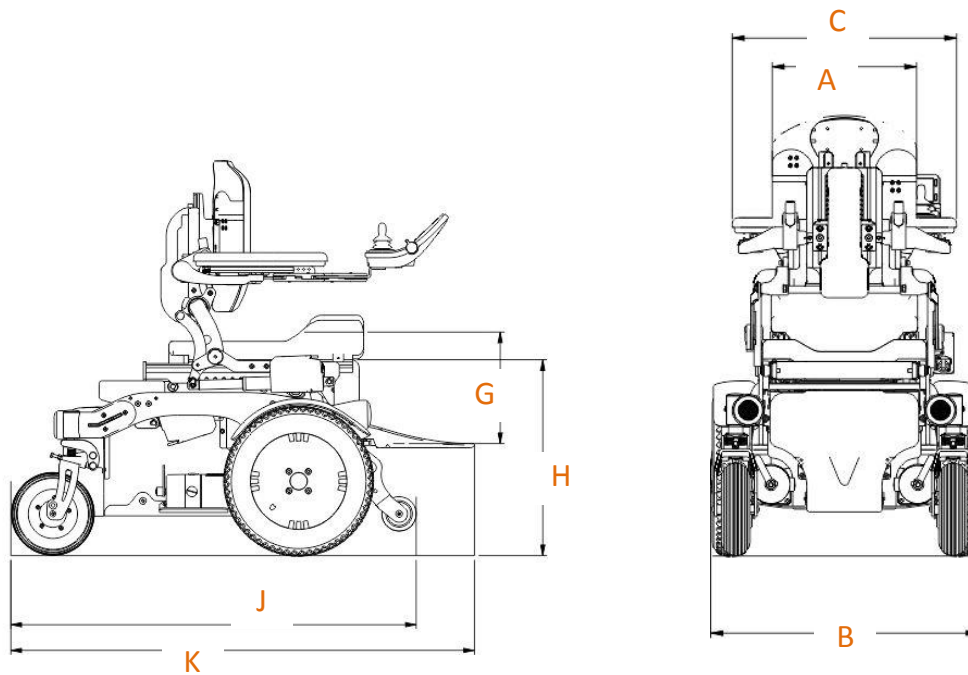

A	300 mm	340 mm	380 mm	420 mm
B	560 mm			
C	495 mm	535 mm	575 mm	615 mm
G	MIN 270 mm – MAX 480 mm See section 3.10			
H	Wheels Ø320: 46.0 cm Wheels 3.00-8: 48.0 cm			
J	FWD: 945 mm			
K	FWD: 1100 mm			

6.3.2 - Version with biomechanical movements

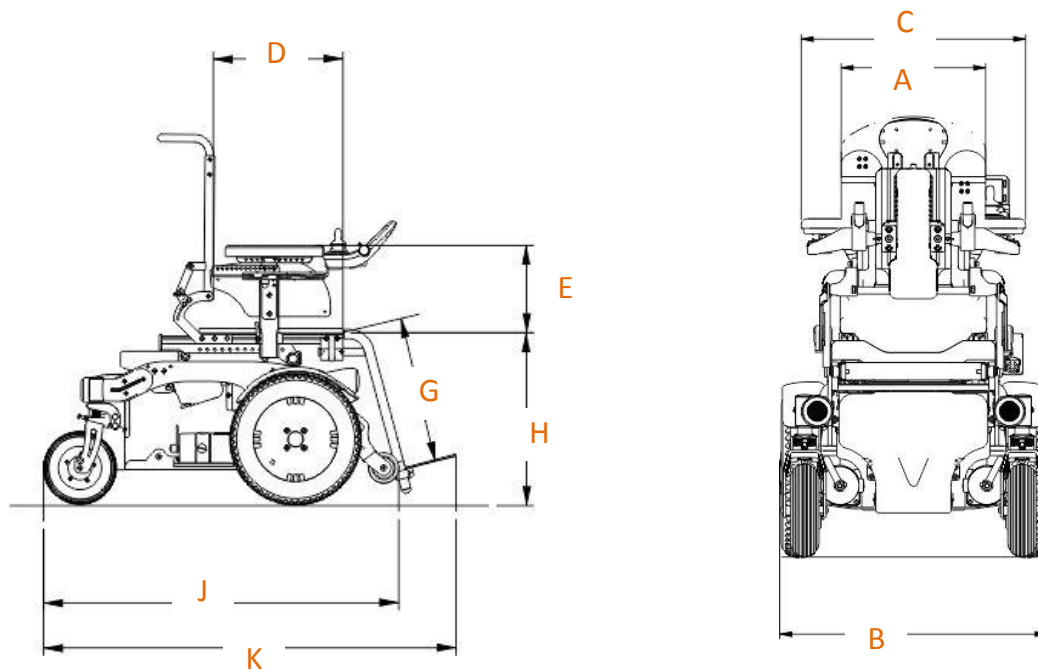

A	300 mm	340 mm	380 mm	420 mm
B	560 mm			
C	495 mm	535 mm	575 mm	615 mm
D	MIN 300 mm MAX 420 mm	MIN 300 mm MAX 460 mm	MIN 300 mm MAX 500 mm	MIN 300 mm MAX 520 mm
E	230 mm – 300 mm			
G	MIN 150 mm – MAX 480 mm See section 3.18			
H	Wheels Ø320: 46.0 cm Wheels 3.00-8: 48.0 cm			
J	FWD: 945 mm			
K	FWD: 1100 mm			

7 Warranty terms

The product is globally guaranteed for 24 months **with the exception of the batteries that are guaranteed for 6 months** from the delivery to the first user. The warranty covers defects in materials or workmanship. The warranty doesn't cover parts subject to usury or damaged parts by: overload, misuse, alterations and repairs made by unauthorized third parties from the manufacturer. The warranty expires in case of tampering, improper storage, unauthorized or incorrect maintenance.

7.1 Serial number

For any report or assistance request, please communicate the serial number mentioned on the label in the position shown in figure.

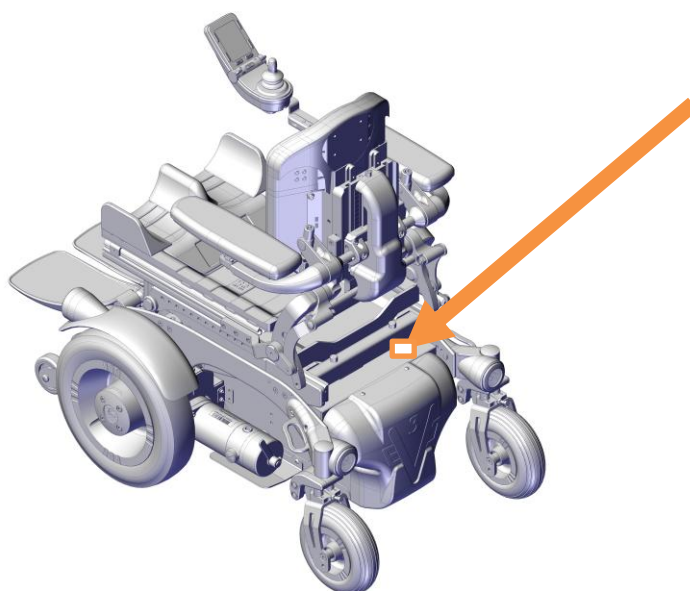

Figure 195

EVO 3

Neatech.it s.r.l.
Via A. De Curtis 4/a
80040 Cercola (Na) Italy
ph. +39 081 5551946
fax +39 081 5552507
e-mail info@neatech.it
www.neatech.it