

karma

User manual

Leon F Versus



A Better Wheelchair, A Better Fit

Version: ENG 02-2020

1. Index

1. Index	3
2. How to contact Karma	8
3. Declaration of conformity	10
4. Introduction	11
5. Used symbols for warning, caution and note	13
6. Warranty	14
7. Intended use / intended user	15
8. Intended environment	15
9. Tyre pressure	15
10. The wheelchair	16
10.1. Chassis	16
10.1.1 Chassis suspension	16
10.1.2 Lights and reflectors	17
10.1.3 Battery compartments	17
10.1.4 Main fuse	19
10.1.5 bumper wheels (optional)	19
10.1.6 Seat lift (optional)	20
10.2 Seat	21
10.2.1 Versus seating frame	21
10.2.2 Postural seat cushion	22
10.2.3 Seat rail	22
10.2.4 Seat tilt (optional)	23
10.2.5 Upholstered backrest	24
10.2.6 Backrest	24
10.2.7 Upholstered armrest	27
10.2.8 Legrest	29
10.2.9 Powered legrest adjustment (optional)	30
10.2.10 Upholstered headrest (optional)	31

10.2.11 Upholstered hip support (optional)	31
10.2.12 Positioning belt (optional)	32
10.3 The controls	33
10.3.1 Side steering control	33
10.3.2 Desktop control (optional)	33
11. The first set up	34
11.1 Chassis suspension	34
11.1.1 Spring setting	34
11.2 Seat adjustments	36
11.2.1 Seat depth	36
11.2.2 Seat width	37
11.2.3 Legrest length (Lower leg adjustment)	40
11.2.4 Legrest angle	41
11.2.5 Footplate angle	41
11.2.6 Hip support settings	42
11.2.7 Positioning belt	44
11.3 Joystick mount settings	45
11.3.1 Depth adjustment swing away side control:	45
11.3.2 Height adjustment side control	45
12 Control panel	46
12.1 Charging socket	46
12.2 Joystick	46
12.3 Display	47
12.3.1 Battery indicator (top bar)	47
12.3.2 Focus light (top bar)	47
12.3.3 Profile name (main screen)	48
12.3.4 Clock (main screen)	48
12.3.5 Speed display (main screen)	48
12.3.6 Speed bar (main screen)	49

12.3.7 Inhibit (main screen)	49
12.3.8 Set functions (main screen)	49
12.3.9 Additional options (main screen)	50
12.3.10 Message screen (main screen)	50
12.3.11 Current profile (base bar)	52
12.3.12 Motor temperature (base bar)	52
12.3.13 Control system temperature (base bar)	52
12.3.14 Wheelchair lock	52
12.4 Buttons	54
12.4.1 On/off button	54
12.4.2 Horn button	54
12.4.3 Speed decrease button	54
12.4.4 Speed increase button	55
12.4.5 Mode button	55
12.4.6 Profile button	55
12.4.7 Hazard Warning Button and LED	55
12.4.8 Lights Button and LED	55
12.4.9 Left Indicator Button and LED	55
12.4.10 Right Indicator Button and LED	56
12.5 Jack sockets	56
12.5.1 External profile switch jack	56
12.5.2 External on/off switch jack	56
12.6 R-net Connectors	57
12.7 Joystick	58
13 Electric system	59
13.1 Batteries	59
13.2 Fuse	60
14 Using the wheelchair	61
14.1 General warnings and advices	61

14.2 Use in combination with other products _____	62
14.3 Hot and cold surfaces _____	62
14.4 Danger of pinching _____	63
14.5 Surroundings _____	64
14.6 Precautions to prevent dangerous situations _____	64
14.7 Use on slopes: driving on downhill slopes _____	65
14.8 Use on slopes: driving on uphill slopes _____	66
14.9 Driving on sideways slopes _____	67
14.10 Obstacle climbing _____	68
14.11 Use in presence of electromagnetic fields, e.g. from cell phones. _____	69
15 Driving the wheelchair _____	70
15.1 Driving in general _____	70
15.2 Driving technique _____	71
15.3 Stopping the wheelchair _____	72
16 Using the powered seat functions _____	72
16.1 Using additional function of the wheelchair menu _____	73
17 Handling the mechanical brakes _____	73
17.1 Release the mechanical brakes _____	74
18 Charging the maintenance free batteries _____	75
18.1 Battery level _____	75
18.2 Charging socket _____	77
18.3 Disposal of broken or worn out batteries _____	78
19 Transport of the wheelchair _____	79
19.1 Transportation using Dahl Docking station _____	79
19.1.1. Mounting of the Dahl locking adapter on the wheelchair _____	80
19.1.2. Locking procedure _____	86
19.1.3. Unlocking procedure _____	87
19.1.4. Manually unlocking in case of electric failure or accident _____	87
19.1.5. Safety belt _____	88

19.2 4-point Tie-down belts _____	92
19.2.1 Safety belt: _____	94
19.2.2 Backrest, legrest and headrest settings during transportation. ___	97
9.3 Transportation on an airplane _____	98
19.3.1. Batteries _____	98
19.3.2. The wheelchair's dimensions and weight _____	98
20. Maintenance and repairs _____	99
20.1 Battery charging _____	99
20.2 Short term storage _____	99
20.3 Long term storage _____	100
20.4 Tools _____	101
20.5 Wheels and tires _____	102
20.5.1 Puncture repair _____	102
20.6 Cleaning _____	103
20.6.1 Upholstery, cloth / 3D mesh _____	103
20.6.2 Metal surfaces _____	104
20.6.3 Plastic covers _____	104
20.7 Brake release, freewheel mode _____	104
20.8 Battery replacement _____	105
20.8.1. Replacing the batteries _____	106
20.8.2 disposal of the batteries. _____	109
21 Refurbishment and re-use of the product. _____	110
22 Disposal of the product _____	110
23 Trouble shooting _____	111
23.1 Diagnostics R-Net LCD _____	112
24 Technical specifications _____	113
25 Accessories _____	115

2. How to contact Karma

head office Karma

karma

Karma Medical
NO.2363, Sec. 2
University Road
Min-Hsiung Shiang
Chia-Yi 621
Taiwan (ROC)
www.karmamedical.com

European representative:

karma

Karma Mobility Spain S.L.
C/ Periodista Francisco Carantoña Dubert nº23 bajo
33209 Gijón (Asturias)
Spain

phone: +35 984 39 09 07
mail: karma@karmamobility.es
web: www.karmamobility.es

Produced and published by Karma Medical, Taiwan
Technical changes and print errors prohibited.

3. Declaration of conformity

karma

Declaration of Conformity

As a wheelchair manufacturer, the company:

KARMA MEDICAL PRODUCTS CO., LTD
No.2363 Sec.2 UNIVERSITY RD., MIN-HSIUNG
SHIANG, CHIA-YI 621, TAIWAN

And the European representative:

KARMA MOBILITY, S.L.
C/ PERIODISTA FRANCISCO CARANTOÑA
DUBERT, 23 Bajo 33209 GIJÓN - ASTURIAS (SPAIN)

declare under his sole responsibility that the wheelchair products:

Power Wheelchairs products: Leon Versus Series

have been classified as Class 1 and are manufactured in conformity with the provisions of the Medical Device Directives 93/42/EEC 2007 and 2007/47/EC, and are in conformity with relevant European harmonization standards of EN 12184:2014.

Signature :

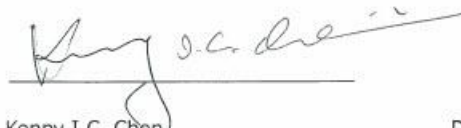

Kenny I.C. Chen
General Manager

Date : 2020
Feb. 5

4. Introduction

Congratulation with your new Karma product! This product has been made with great care and dedication. The Karma product will increase your freedom of mobility and independence. Karma and it resellers all over the world are there to support in any way. So, if you have questions or suggestions about our products, do not hesitate to get in contact with us at globalsales@karma.com.tw

Before you use the Karma product, we strongly recommend you read this manual carefully and always keep it with your product. This way you are always able to find additional information when needed.

Karma runs the policy of continuously product improvement. Therefore, pictures of products or options as shown in this manual might be different from what you see in this manual. Karma reserves the right to make changes to the product without prior notice.

chassis number

The chassis number is a very important number. Your wheelchair will be stored in our data system under this main number. You can find the number on the rear end of the chassis.

Karma Medical Products Co., Ltd.		
2363, Sec. 2 University Rd., Min-Hsiung, Chia-Yi 621, Taiwan		
TYPE	Leon <input type="checkbox"/> RWD <input type="checkbox"/> FWD	
	<input type="checkbox"/> SLS <input type="checkbox"/> CPT <input type="checkbox"/> VRS <input type="checkbox"/> KML 	
V max.	<input type="checkbox"/> 6 km/h <input type="checkbox"/> 10 km/h <input type="checkbox"/> 12 km/h	
	<input type="checkbox"/> 60 kg <input type="checkbox"/> 136 kg	
	max. <input type="checkbox"/> 6°	SN: <input type="text"/>
		



Chassis serial plate

The used symbols on the chassis plate are explained below:



describes the model and type of the product.



stands for indoor- and outdoor use (Class B).

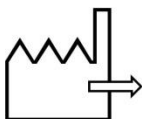

stands for the date of production.



this icon stands for the maximum driving speed.



this icon stands for the maximum slope to drive on.



this icon stands for the maximum user weight.

SN:

stands for the chassis serial number.

5. Used symbols for warning, caution and note

General warnings are indicated by a symbol. There are three levels of warnings:

1. warning



If you see this sign, please use extreme caution where this symbol appears. Neglecting these warnings can lead to personal or material damage.

2. caution



If you see this symbol, use caution to prevent dangerous situations.

3. note



If you see this symbol we provide additional information which might be good to know. Please take notice if this information.



- Before using the wheelchair, you should read this manual to get familiar with this product.
- Make sure the local reseller has set up the product in a proper way to exactly fit your needs and requirements.
- Always be accompanied by a attendant person when you drive the wheelchair for the first time.
- The first drive should take place in a safe and wide area so you can get acquainted to your wheelchair without any danger.
- Always start to drive the wheelchair in the lowest possible driving speed first.

6. Warranty

Karma Medical supplies three years of warranty on this product. Your local supplier will carry out this warranty. For batteries and battery charger you receive one-year warranty.

For a warranty claim you get in contact with our local authorized Karma reseller or directly with Karma Europe BV. Make sure you also provide the chassis serial number of your product.

The warranty does not apply to damage or faults of the product caused by wrong or improper use, or neglected maintenance. The evaluation of it is the privilege of Karma Medical or a representative to be appointed by Karma Medical.

This guarantee does not apply to components susceptible to wear such as tyres, seat covers, arm rests etc.

Karma Medical reserves the right to alter the specifications at any time. No responsibility can be accepted for any changes in the specifications.

Change of specification can be caused by e.g. availability of parts, product improvement based on market experience, changed legislations etc.

WARNING

The use of non-original parts on this product can lead to personal or material damage. Karma Medical cannot be held responsible for these results.

Repairs executed by unauthorized persons can lead to personal or material damage. Karma Medical cannot be held responsible for these results.

If you have any doubt about the service provided to your wheelchair, please contact Karma Medical Taiwan for information.

7. Intended use / intended user

The Leon Versus powered wheelchair is meant to provide mobility to persons who are not able to walk, stand or use a manual wheelchair, but who are very well able to control and use the interface of a powered wheelchair. Apart from the horizontal mobility, the Leon Versus provides the user with mobility in vertical direction. This for example to reach light switches, a doorbell and doorknobs. The wheelchair is designed for a maximum user weight of 136 kg. It is strongly suggested to have the use of the wheelchair evaluated by a trained doctor, therapist or other qualified and trained staff.

This wheelchair is not suitable for persons who do not have the cognitive skills to drive a powered wheelchair by themselves. Also, it is not suitable for visually impaired persons.

8. Intended environment

The Leon Versus powered wheelchair is not restricted to only inside or only outside use. Because the large driving wheels are placed in the front, the wheelchair is extremely maneuverable and is able to cope with many terrain differences. This, combined with the compact size of the Versus and the excellent speed range and battery capacity, makes the wheelchair suitable for both indoor and outdoor use. It is allowed to use the wheelchair in different weather conditions. It can be used at temperatures of -25 degrees up to maximum 55 degrees Celsius and the charger operate temperatures is 0 up to 40 degrees Celsius. It however must be noticed that metal or plastic surfaces of the wheelchair can become very hot when exposed to direct sun for longer time. Because of the harmful combination of saltwater and sand it is advised not to use the wheelchair on beaches. We advise to clean the wheelchair after having been in contact with sand and/or saltwater as described in the paragraph "cleaning".

9. Tyre pressure

The Leon Versus uses air filled front tyres and solid or air-filled tyres in the rear. The choice of having solid or air-filled rear tyres is made by the user during the ordering of the wheelchair. In order to prevent tyre damage and to preserve the performance of the wheelchair, the tyre pressure must be checked at least on a monthly basis. The tyre pressure should be:

Front air-filled tyres (big)	:	max. 300 Kpa / 43 PSI / 3.0 bar
Rear air-filled tyres (small)	:	max. 200 Kpa / 29 PSI / 2,0 bar

10. The wheelchair

10.1. Chassis

The chassis is the base of the wheelchair. It contains wheels, drive motors, batteries, electronics and seat lift. The steel parts of the chassis are electrolytic anodized, and powder coated to ensure a long life without corrosion.



Each of the front wheels is propelled by a powerful drive motor. These motors also take care for the steering of the wheelchair. With this system it is possible to turn on the spot. This makes the wheelchair optimal for indoor use.

10.1.1 Chassis suspension

The chassis has independent suspension on each of the four wheels. The stiffness can be adjusted to your personal requirements.



front suspension

rear suspension

10.1.2 Lights and reflectors

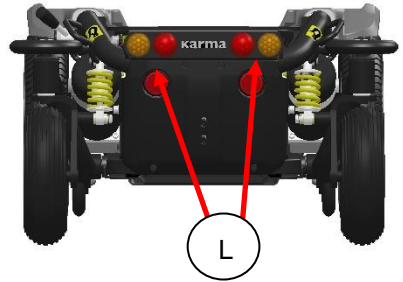
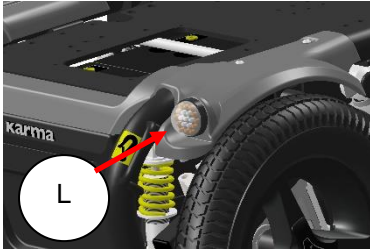

The chassis has very strong and bright LED lights to make sure you can have a safe drive in the dark. The orange reflectors on both sides and the red reflectors on the rear also make you visible for other people as well. The lights fulfill the European requirements. (E marked)

The additional LED indicators give our environment clear information in which direction you want to go.

10.1.3 Battery compartments

The batteries are mounted as low as possible in the center into the chassis, to provide an optimal center point of gravity. This results in a maximum stability of the wheelchair. The compartment can hold maintenance free batteries up to 80Ah. For the specification of the batteries see the chapter technical specifications.

The maintenance free batteries can be reached from the front side.



the front battery box

The batteries are placed in a box with a handle for easy changing.



Battery box slides out of the chassis

For more details of changing the batteries, please check chapter 18 of this manual.

⚠ CAUTION

When pulling the battery out of the box do mind to not overstretch the cables. This might lead to technical failure.

⚠ CAUTION

Before removing the batteries, first remove the main fuse. This to reduce the risk of short circuit or electrical shock. See the chapter of the main fuse

⚠ CAUTION

Before reconnecting the battery, read the wiring instructions on the inside of the battery cover.

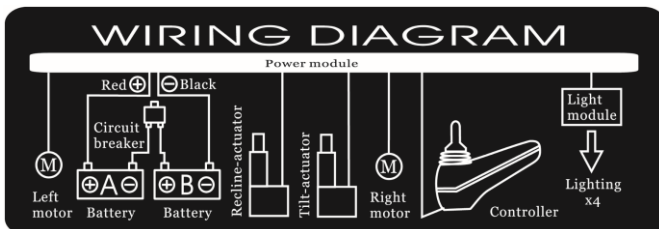

10.1.4 Main fuse

The chassis contains a main fuse which is located at the front of the chassis.

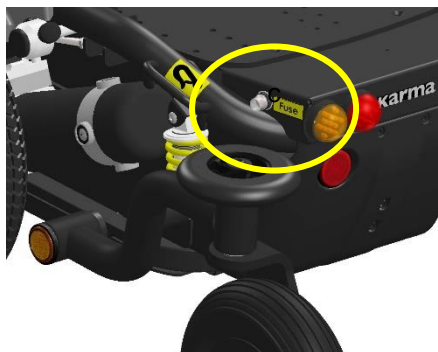

position main fuse



main fuse

The main fuse protects the whole electrical system of the wheelchair. This fuse will only blow if there is a serious problem on the wheelchair.

⚠ CAUTION

If the main fuse has blown, do not replace the fuse immediately. First contact your local supplier to have the wheelchair checked.

⚠ CAUTION

Only use original main fuses as replacement. Using other fuses might lead to material damage to the wheelchair.

10.1.5 bumper wheels (optional)

Bumper wheels available to protect the rear end to protect against damage when bumping into a wall. It protects the wall and the wheelchair.



Rear end bumper wheels

10.1.6 Seat lift (optional)

The seat lift is centrally mounted into the chassis. With this lift the seat can be raised step less up to 300mm. This enables the user to have more freedom of movement, not only in horizontal area, but also in the vertical area. The seat lift can be stopped at any height and will be automatically locked in position.

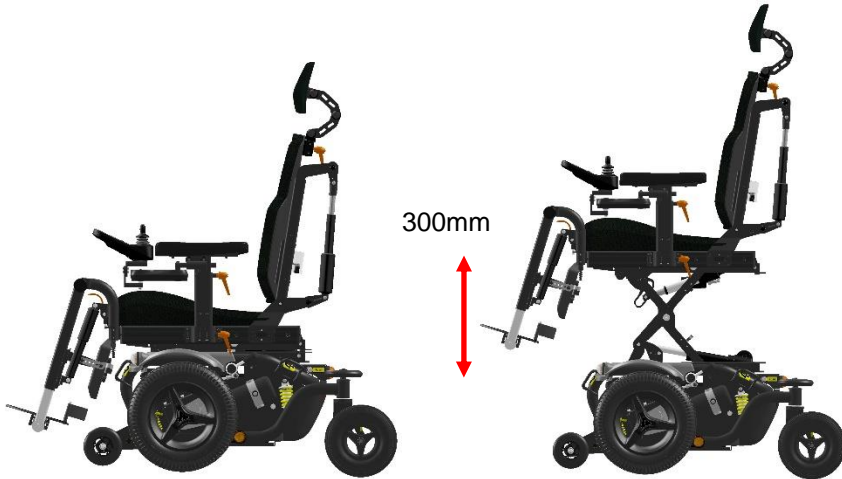

Whilst lifting the seat, the driving speed will always automatically be reduced to gain maximum stability. At high seating position also, the seat tilt will be blocked to gain maximum stability. the seat height can be set to every height position by the user.

CAUTION

be careful driving in high seating position at slopes. We strongly suggest to only use the seat lift on flat areas. Lifting high on a steep slope might lead to instability and might cause personal or material damage.

NOTE

The seat lift can also be very helpful for transferring or lifting the user in or out of the wheelchair.

10.2 Seat

The seating system is designed to optimize the seating comfort to the user. It can be adjusted in seat depth and seat width. A rail on each side provide mounting point for accessories like hip supports or safety belts. The seat pan is flat so other seating cushion can be fitted on to the seat as well.



10.2.1 Versus seating frame

The best possible sitting support is accomplished by an individual combination of a wheelchair base, and the proper seating elements. The Versus seat allows the adjustment of the seat and backrest angle to each user's exact needs. In addition, the various modular seating elements can be chosen within the Versus seat system, depending on the functional limitations of the user. By that the seat can perfectly be assembled for each specific user.

Versus seat system advantages:

- Interchangeability of various seating elements
- Modular product structure with many options

User Benefits:

- Optimal seating support
- Good pressure distribution
- Perfect posture
- Excellent comfort



The Versus seat system includes the following elements:

- Seat cushions
- Backrests
- Leg supports
- Armrests
- headrests
- Seating elements
- Versus cleaner



10.2.2 Postural seat cushion

The padded cushion is available in various sizes and offer optimal comfort and support. The covers are available in 3D mesh or water-repellent substance. The cushion is fixed with clips on the seat frame.



i NOTE

using other cushions with different thickness might influence the biomechanical function of the legrest and or backrest.

10.2.3 Seat rail

on each side of the seat frame there is a rail to mount different accessories to the wheelchair.

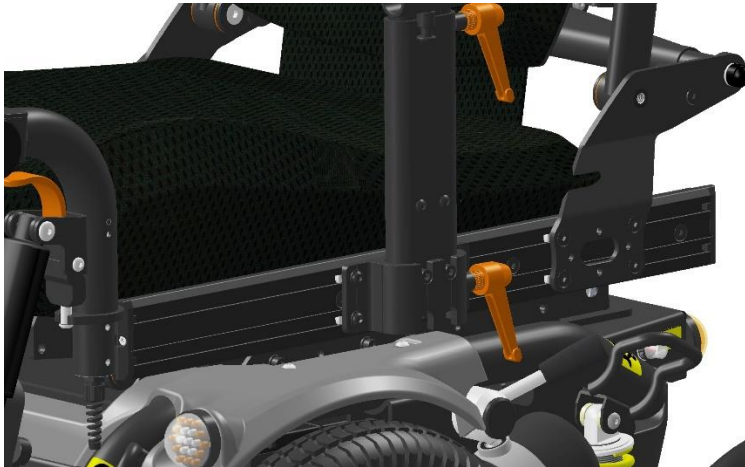

seat rail

10.2.4 Seat tilt (optional)

The seat tilt can be used to release pressure. The tilting angle is from 0 to 45°. The tilt can also be used when driving down a slope for compensating the negative seat angle. This provides a more stable seat position and safe driving.



If the tilt is activated over a certain angle, the driving speed will be reduced. This to reduce the risk of danger whilst driving at high speed.

CAUTION

Always drive carefully on slopes. The angle of the slope has great influence on the total stability of the wheelchair.

CAUTION

When tilting always check if there are no obstructions close to the wheelchair. Especially in the front or rear of the wheelchair.

CAUTION

When tilting, the wheelchair will get longer. This has influence on the driving characteristics of the wheelchair. Make sure there is enough space to drive.

10.2.5 Upholstered backrest

The upholstered backrest is available in different lengths and width sizes to give the users maximum support and comfort. The cloth is available as 3D mesh or breathing but waterproof cloth.



10.2.6 Backrest

Fixed backrest



Versus fixed mount backrest recline.

The backrest angle can be set by changing the length of the threaded rod of the backrest tube.

Manual adjustable backrest (optional)



Versus mechanical adjustable recline

The mechanical adjustable recline uses a stepless telescopic tube with quick release and lock lever action. The mechanical recline setting has the same dynamic angle setting as the power recline system.

Power recline backrest (optional)

The power recline backrest can be set from 85° to 130°. It gives the user the possibility to move into a laying position or a very active sitting position.



If the reclined backrest position is activated over a certain angle, the driving speed will be reduced. This to reduce the risk of danger whilst driving at high speed.

CAUTION

When reclining always check if there are no obstructions close to the wheelchair. Especially in the rear of the wheelchair.

CAUTION

When reclining, the wheelchair will get longer. This has influence on the driving characteristics of the wheelchair. Make sure there is enough space to drive.

10.2.7 Upholstered armrest

T-bar armrest

The T-bar armrest is easy to adjust in height, depth and position. Different upholsteries are available for good support and comfort. The armrest can be detached from the seat frame to allow a side transfer. (fig.1)



T-bar armrest

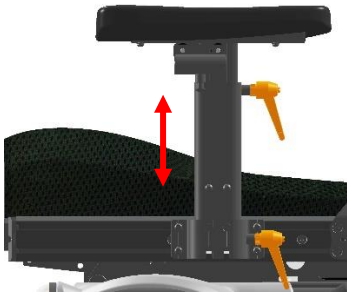

Fig.1

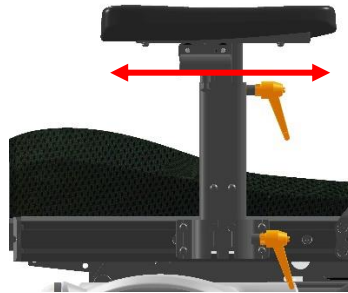

Fig.2

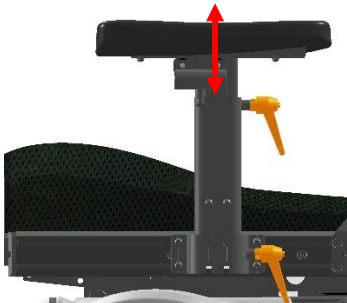

Fig.3

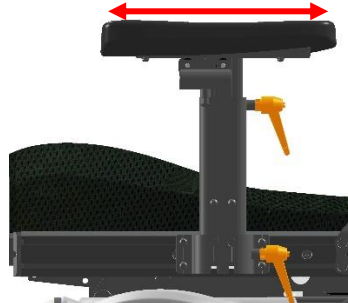

Fig.4

Flip-up armrest

The flip-up armrest is adjustable in height, depth and can hold different sizes of upholstery. The design is made to be flipped up backwards in order to have an easy transfer in and out of the wheelchair. Its open design allows to mount additional hip support on the seat frame as well.



armrest flipped up for transfer

10.2.8 Legrest

The separate legrest uses left and right mounted tubes on which the footplates are mounted. The footplates come in different sizes. The legrest can be adjusted in length (left and right footplate independent) knee angle and footplate angle (left and right independent). The footplates can be flipped up sideways to make a transfer easier. The legrest can be swing out sideways and have a quick release mounting system. Calf support is optional available.

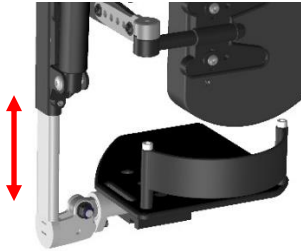

height setting

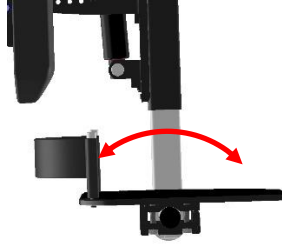

angle setting

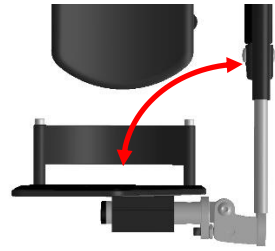

flip up sideways



legrest angle 90°

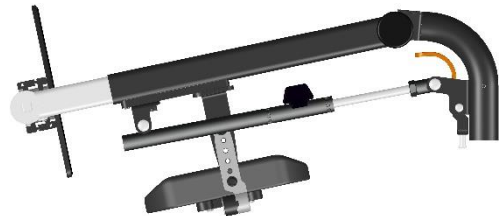

legrest stretched



calf support

10.2.9 Powered legrest adjustment (optional)

With a powered legrest the knee angle can be set from 105° up to a nearly fully stretched leg angle. The biomechanical movement (turning point at knee height) ensures the lower leg length will always be the same.



powered legrest

If the legrest is stretched over a certain angle, the driving speed will automatically be reduced for safety reasons.

CAUTION

When stretching the legrest always check if there are no obstructions close to the wheelchair. Especially in the front of the wheelchair.

CAUTION

When stretching the legrest, the wheelchair will get longer. This has influence on the driving characteristics of the wheelchair. Make sure there is enough space to drive.

10.2.10 Upholstered headrest (optional)

The upholstered headrest is adjustable in height, depth and angle to the requirements of the user. It can be taken off without losing its settings. As an accessory, a rail can be mounted to move the headrest out of center. Another option is a rotation mount to rotate the headrest to the left or right.



i NOTE

If the wheelchair user is transported in a taxi van, we strongly advise to use the headrest. This to provide you optimal stability whilst driving in the taxi.

10.2.11 Upholstered hip support (optional)

The upholstered quick release hip supports offer side support to your hips or upper leg. The support is adjustable in height, depth, width and angle. The soft pads offer good and comfortable support.



upholstered hip supports

10.2.12 Positioning belt (optional)

for positioning, several types of belts are available.

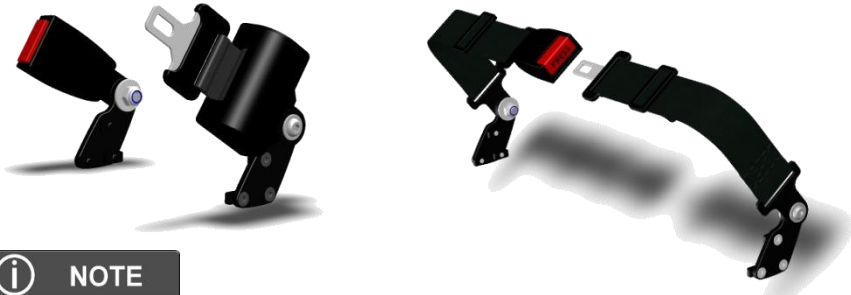

i NOTE

Positioning belts shall not be used as a car safety belt. If transported in a car, the user needs to wear an additional car safety belt. However, we do advise you to wear a positioning belt whilst being transported in a car, just to secure your seat position. As the care safety belt doesn't provide good and secure seat position.

i NOTE

Versus is designed to fit other accessories as well. To mount these different accessories, we refer to the mounting instructions of that specific accessory's supplier.

10.3 The controls

10.3.1 Side steering control



side steering control



side steering, swing away



This wheelchair has a side steering control unit, which is either mounted on the left- or right armrest. The joystick module can be mounted on a fixed bracket or on an (optional) swing away mechanism. This system enables you to sit close to a table.

10.3.2 Desktop control (optional)

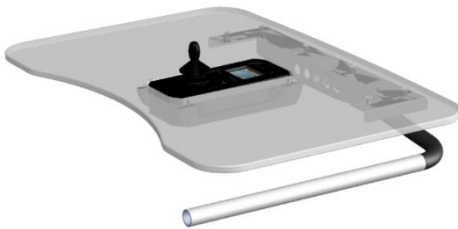

desktop control, driving position

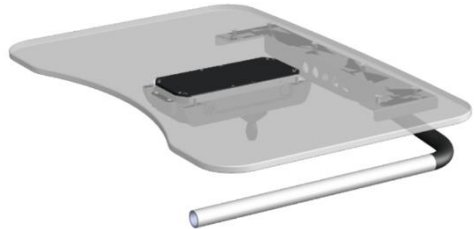

desktop control, flipped up

The desktop control enables the user to have a table with a center mounted build-in joystick module. The table can be flipped up sideways for transferring in and out of the wheelchair. The joystick module can be flipped up to use the table as desktop. When flipped up, the driving mode of the wheelchair is automatically blocked. This ensures a safe use of the wheelchair in any position.

11. The first set up

Before using, the wheelchair needs to be adjusted and set up for the user. In this chapter we will explain all the setup which needs to be done before the first drive.

CAUTION

before using the wheelchair, it is vital to make the right set up for the user. A non-proper set up of the wheelchair might lead to uncontrolled driving which can result in personal or material damage.

11.1 Chassis suspension

The suspension of a chassis has been designed to increase the comfort whilst driving. Also climbing steps will be more easier having suspension on the chassis. But suspension can also be a disadvantage. A suspension which is set to soft has a negative influence on the control of the wheelchair. So, it is very important to have a good mix.

11.1.1 Spring setting

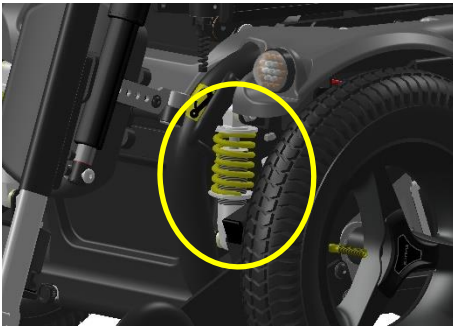

front spring damper unit

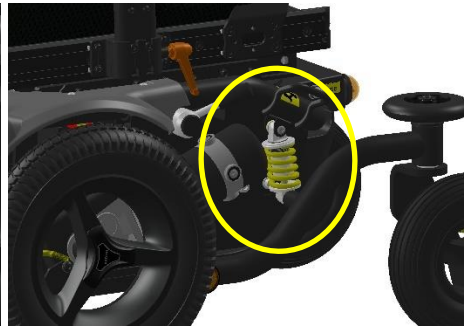

rear spring damper unit

Every Leon each wheelchair chassis has two spring damper units in the front, one for each wheel, and two spring damper units in the rear. The spring damper unit can be set at a certain amount of pre-tension (load) of the spring. The tension of the spring will be set by rotating the threaded ring which is compressing. By rotating the ring, you can either increase the tension (load), or reduce the tension of the spring. Increasing the tension on top of the spring, the wheelchair suspension becomes stiffer. This increases the mechanical traction and improves control. The stiffness of the suspension can also

depend on the user's weight. The settings need to be done by setting and testing. We advise you to start with a stiffer setting, since this results in the best control. If the suspension is too hard, you can set it softer by turning the ring more counterclockwise. to make sure the balance of the left and right spring is the same, we need to measure the setting.

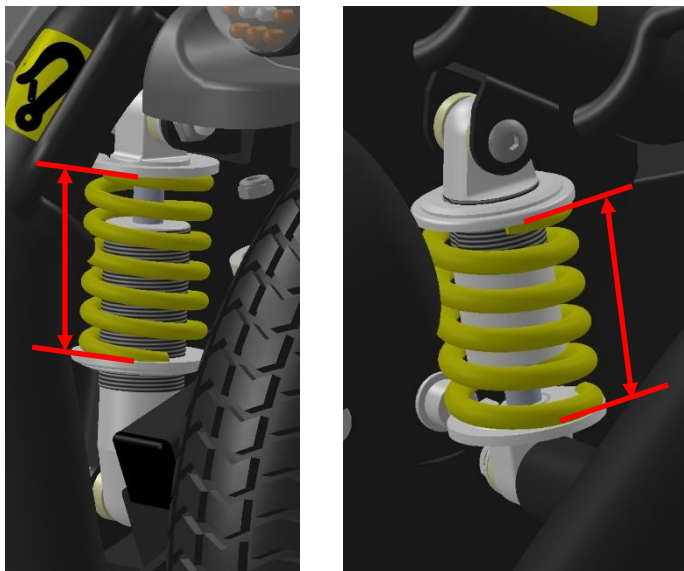

front measuring spring setting rear

The best way is to measure the distance between both rings where the spring is clamped in mm. Make sure that the spring settings left, and right are identical.

⚠ CAUTION

To soft settings of the spring will result in a very spongy behavior of the chassis. The control of the wheelchair will be bad. Avoid soft settings.

⚠ CAUTION

If the springs are uneven set, it might lead to strange driving behavior of the wheelchair. This might result in personal or material damage.

i NOTE

After setting the suspension, always drive first slowly and in an open space to test the result of the setting.

11.2 Seat adjustments

Before using the wheelchair, the seat must be set to the right size for the user. Most of the time this will be done by your local supplier, together with your therapist. A well-adjusted seat will give you optimum support and comfort.

11.2.1 Seat depth

To adjust the seat depth, we move the backrest frame forward or backward. Adjusting the seat depth is done by taking the following steps:



Step 1: loosen the 4 bolts on each side of the backrest bracket (A) using an 3mm Allan key.

Step 2: Slide the backrest frame (left and right side) horizontally in the seat rail to the required seat depth.

Step 3: tighten the screws (A) again.

Step 4: place the seat cushion.

11.2.2 Seat width

To change the seat width, each left- and right frame side can be slide in and out to the required width. Please notice the following steps to change the seat width:

Step 1: take off the side seat pan panels by loosening the top panel bolts (B) first.

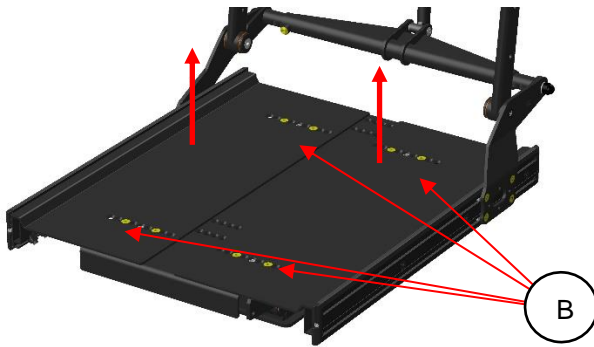

Step2: loosen the bolts (C) of the centre cover and remove them.

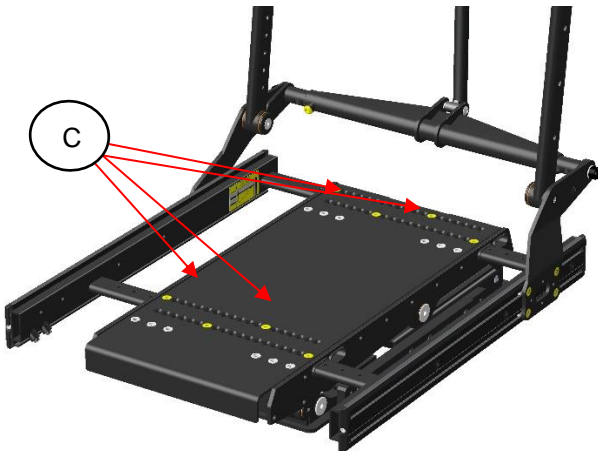

Step 3: take of the plastic bolt covers (D) and loosen the bolts (E) on the left side of the backrest frame first. Then take out he dome shaped bolts (F).

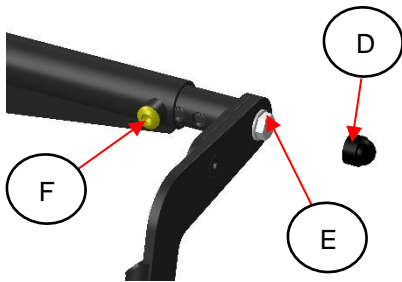

top cover and bolts to loosen

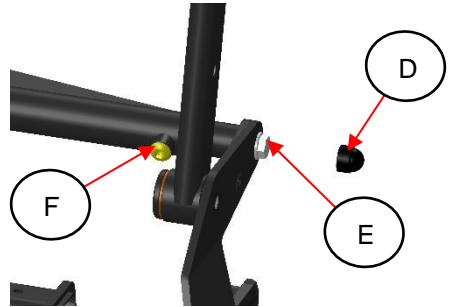

bottom cover and bolts to loosen

Step 3: now pull the frame sideways out. Each step per hole represent 12,5mm on each side, so it will be 25 mm in total. So, if you want to increase the width in total 50 mm, you need to move two steps on both left and right side.

Step 4: secure the right position by mounting the dome shaped bolts into the designated holes again, then tighten the end bolts to fixate that side of the seat.

Step 5: repeat step 3, but this time on the right side.

Step 6: after setting the right width, place back the center seat pan panel, the both side seat pan panels and tighten all bolts.

Step 7: place the seat cushion on top of the seat pane.

Now the seat frame and backrest frame are set to the right size. The next step is to set the backrest and mount it on the backrest frame.

i NOTE

Versus is designed to fit other kinds of backrests and seat cushions as well. To mount these different cushions, we refer to the mounting instructions and the adjustment instructions of that specific backrest and seat cushion supplier.

Setting of the backrest:

After we have set the seat frame width, we now will set the backrest width.

Step 1: We take the backrest mounting frame and we adjust the both side brackets into the right width setting to fit on the backrest frame. To adjust we loosen the bolts (A) and position the both side panel into the right width setting, which is equal to the frame width adjustment.

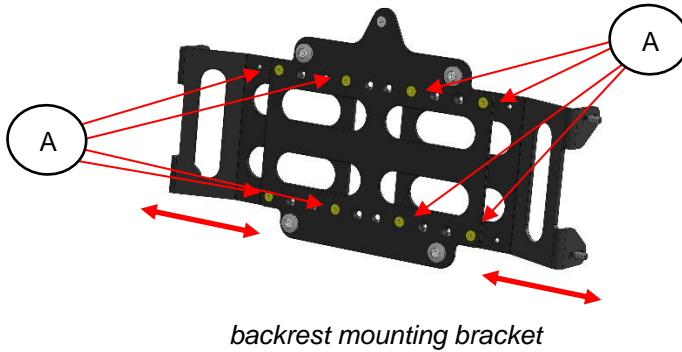

Step 2: place the mounting bracket into the backrest frame and set it to the required height by selecting one of the height settings of the backrest. Tighten the four (B) bolts to secure the mounting bracket into the backrest frame.

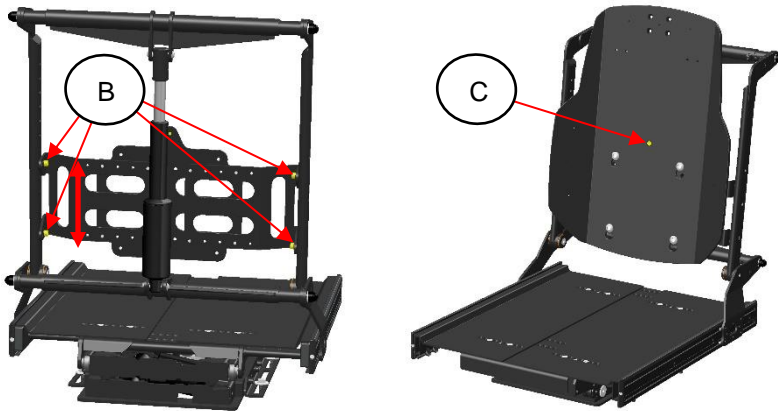

Step 3: place the backrest panel into the mounting frame and secure it by the lock bolt (C).

11.2.3 Legrest length (Lower leg adjustment)

The legrest length is adjustable. Both left and right length is separately adjustable. To set the right length, follow the next steps:

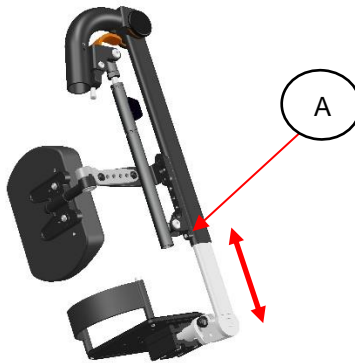

Step 1: slowly loosen the legrest fixation bolt (A), using an Allan key. Just enough to feel the footplate is starting to move.

CAUTION

By loosening the second bolt on the footplate, the footplate might suddenly start to slide down. If the user has his or her foot on the footplate, this sudden movement might cause a shock reaction. It is best to hold the footplate with one hand and loosen the bolt with the other hand.

Step 2: now slide the footplate into the required position.

NOTE

Make sure the legrest is in the right position. The surface pressure on the upper leg part should be equally divided over the total length. A too short or too long adjusted length might lead to pressure points on the upper leg part.

Step 3: if the right length is set, tighten bolt firmly.

NOTE

Versus is designed to fit other kinds of legrest as well. To mount these different legrest and their adjustments, we refer to the mounting instructions of that specific legrest supplier.

11.2.4 Legrest angle

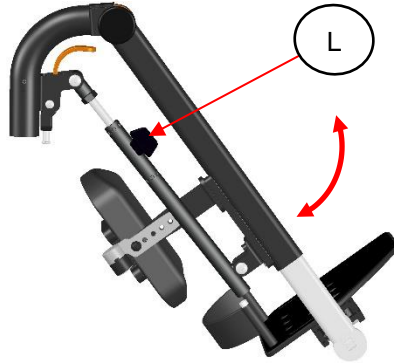

Step 1: to adjust and set the legrest angle, you hold the legrest with one hand and unlock the setting lever (L) with your other hand by pushing it side ways.

Step 2: move the legrest into the required angle position.

Step 3: let go of the adjustment lever, and the legrest will be fixed in the selected angle.

CAUTION

By loosening the handle (L), the legrest might suddenly start to move down. It is best to hold the legrest with one hand and loosen the bolt with the other hand.

The legrest angle can optionally be power adjusted. How to control the powered legrest is explained in chapter 16.

11.2.5 Footplate angle

The footplate angle can be adjusted for the left and right footplate separately. To adjust the angle, follow the next steps:

Step 1: insert the Allan key into the 4 adjustment screws (F) on the outside of the footplate.

Step 2: move the footplate to the required angle.

Step 3: tighten the footplate fixation bolts again (F).

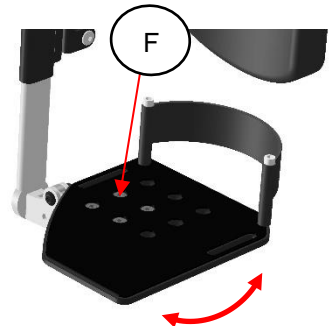

11.2.6 Hip support settings

The optional hip supports are fully step less adjustable in position, height, depth and angle. It can easily be taking of the chair using a quick release system, without its settings.

11.2.6.1 Set the side position on the seat rail

To set the position on the seat rail, take the following steps:

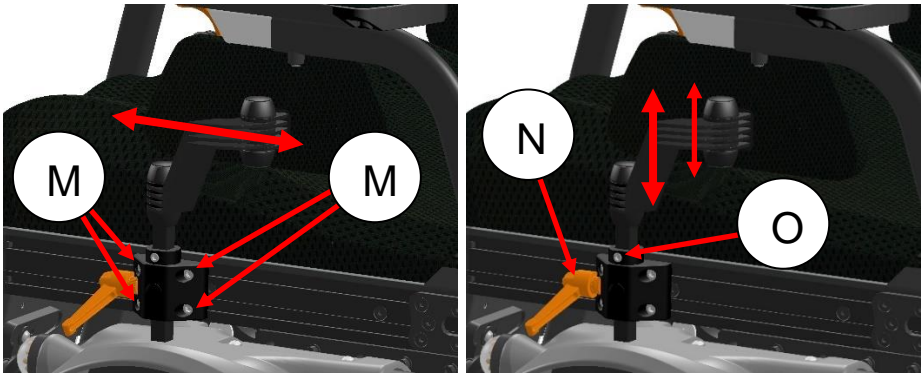

Step 1: loosen the four bolts (M) using a 5mm Allan Key.

Step 2: move the hip support into the required position.

Step 3: tighten the four bolts, the setting is now fixed.

11.2.6.2 Setting the height position of the hip support

To set the height of the hip support, take the following steps:

Step 1: loosen the lever knob (N) and lift the hip support into the right position.

Step 2: loosen the bolt (O) of the fixation ring using a 4mm Allan key and reposition this ring against the mounting block as a stopper.

Step 3: tighten the nut of the fixation ring. Now the height is set and secured.

11.2.6.3 Setting the angle position of the hip support

To set the angle of the hip support, take the following steps:

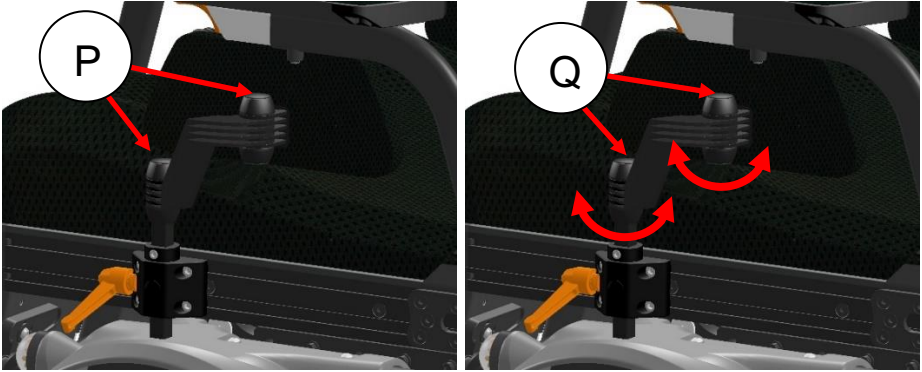

Step 1: remove the rubber covers (P) of the friction joints.

Step 2: loosen the friction bolts (Q) so the padding can be moved.

Step 3: tighten the frictions bolts. Now the position is fixed.

Step 4: punt the covers back on to the friction joints.

CAUTION

If you loosen up the bolts too much, the hip support might start to suddenly move. This might cause a little shock reaction on the user in the wheelchair. It is better to loosen the bolts bit by bit and every time try to move the hip support pad. The friction will keep it stable. Make sure you hold the hip support with one hand and loosen the bolt with the other hand.

NOTE

The hip support is only to be combined with the flip up armrest system.

11.2.7 Positioning belt

The positioning belt can be mounted in two different ways:

- 1) In the predestined mounting holes on the backrest hinge.
- 2) mounted on the seat rail, this gives more flexibility of positioning the belt.

The kind of mounting may also depend on the type of armrests or hip supports which are mounted.

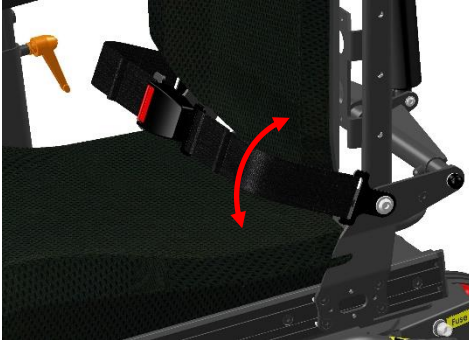

mounted on backrest hinge

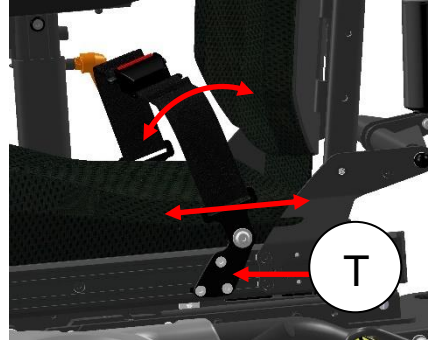

mounted on seat rail

To adjust the seat belt position on the seat rail we take following steps:

Step 1: loosen the 3 bolts (T) using 3mm key, until the bracket can be moved.

Step 2: move the bracket in the required position.

Step 3: fasten the bolts.

CAUTION

Make sure the brackets are tightening properly to avoid sliding of the seat belt along the seat rail. A sliding seat belt might result in poor seating position of the user.

NOTE

The positioning belt is not to be used as a safety belt. If the wheelchair is transported in an occupied position, the user needs to wear a safety belt which is mounted in the vehicle he or she is transported in. Additionally, we strongly advice to keep the positioning belt strapped as well as it secures you position in the seat. A car safety belt doesn't fulfil that support. So, use both and you are safe and positioned.

11.3 Joystick mount settings

The side swing away control joystick module is adjustable in depth, height and angle. To adjust the swing away part, take the following steps:

11.3.1 Depth adjustment swing away side control:

To set the height adjustment of the swing away side control, follow the next steps:



Step 1: loosen the bolts (V) using an Allan key.

Step 2: move the bracket into the required height position.

Step 3: fasten the bolts again.

11.3.2 Height adjustment side control

To set the depth adjustment of the side control, follow the next steps:

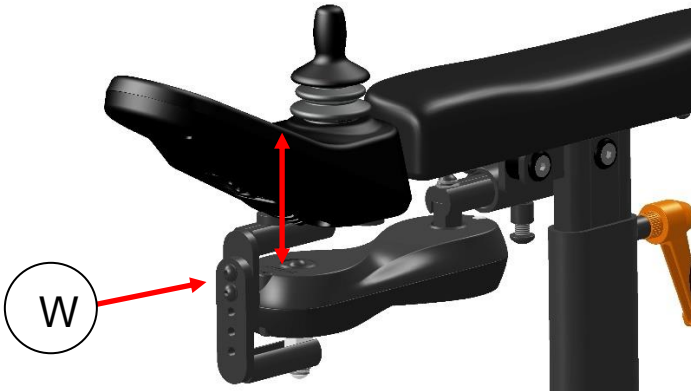

Step 1: loosen the 2 bolts (W) using a 3mm Allan key.

Step 2: move the control in the required height position.

Step 3: tighten the bolts again.

12 Control panel

The wheelchair uses a color screen joystick module. With this joystick module all functions of the wheelchair can be controlled. This joystick module can be mounted on the left or right armrest or even as an integrated desktop unit.

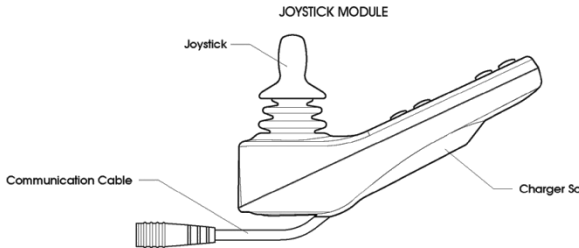

The joystick module contains a few major components which will be explained separately.

12.1 Charging socket

The charging socket is used to charge the batteries. Whilst charging the batteries, the driving of the wheelchair is automatically blocked.

12.2 Joystick

The primary function of the joystick is to control the speed and direction of the wheelchair. The further you push the joystick from the center position the faster the wheelchair will move. When you release the joystick, the brakes are automatically applied. If the wheelchair is fitted with powered seat functions, the joystick can also be used to move and select the specific powered seat function.

Several different shapes of joystick knobs are available to optimize the control of the joystick.

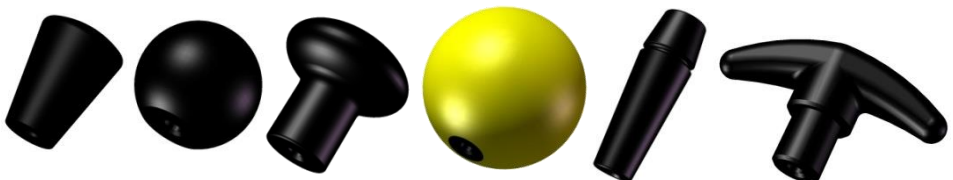

12.3 Display

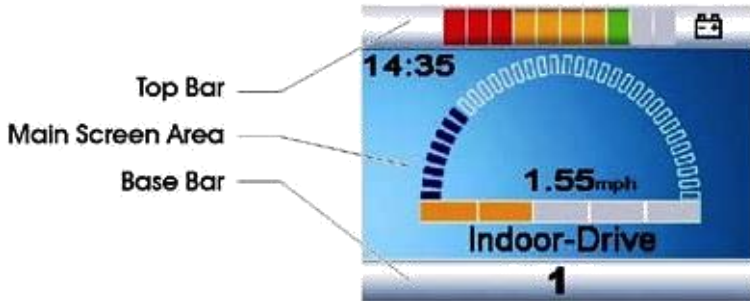

The color LCD screen is split into 3 areas of information. The Top Bar, the Base Bar and the Main Screen Area.

12.3.1 Battery indicator (top bar)



This displays the charge available in the battery and can be used to alert the user to the status of the battery. If all LED's are on, the batteries are fully charged. If the capacity is lowered one by one an LED will erase. The bar is divided into three color zones: Green, orange and red. If only the LED are left it means the batteries will be almost empty and need to be charged. beside the color you also have different LED lighting modes:

LED's Steady: This indicates that all is well.

LED's Flashing Slowly: The control system is functioning correctly, but you should charge the battery as soon as possible.

LED's Stepping Up: The wheelchair batteries are being charged. You will not be able to drive the wheelchair until the charger is disconnected and you have switched the control system off and on again.

12.3.2 Focus light (top bar)



When the wheelchair system contains more than one method of direct control, such as a secondary Joystick Module or a Dual Attendant Module, then the Module that has control of the wheelchair will display the In-Focus symbol.

12.3.3 Profile name (main screen)

The profile name shows in which drive profile you are now. The name of the profile can be programmed to your wishes by your local supplier. The wheelchair can have up to 8 different driving profiles. Each profile is set to a certain environment you want to drive in. Standard the wheelchair comes with an indoor- and outdoor profile.



12.3.4 Clock (main screen)

The clock displays the current time in a numeric format. The clock is user adjustable. Adjustable options are:

- Visibility, whether the clock is displayed on screen.
- The display format, 12 or 24 hour.
- The time, the user can adjust the time.



12.3.5 Speed display (main screen)

This gives a proportional display of the wheelchairs speed. The Arc begins at 0% and has a programmable maximum. The programmable parameter is Max Displayed Speed. The speeds can be set in mph or km/h. The standard setting km/h.



12.3.6 Speed bar (main screen)

This speed bar displays the current maximum speed setting. It contains 5 steps in speed. These steps can be selected using the speed buttons, explained in the chapter "Buttons"

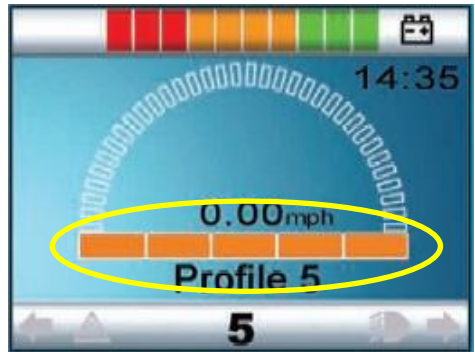

12.3.7 Inhibit (main screen)

If the speed of the wheelchair is being limited; for example, by a raised seat, then this orange symbol will be displayed.

If the driving is stopped by an inhibit, the bunny will flash in red.

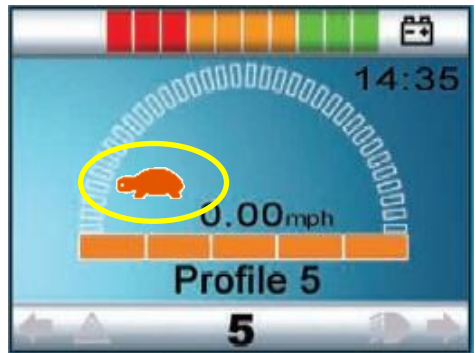

12.3.8 Set functions (main screen)

Displays the sections of the chair currently selected for movement, the name given to the selection and a direction arrow showing what sort of movement is available.



Besides the screen you use for driving or controlling the seat functions, there are also other screens which show information. The most common screen messages are explained in the next chapters

12.3.9 Additional options (main screen)

Additional screens can show the additional options of the electronic system. for example: Bluetooth, environmental control, mouse function. for more detailed information n about these options, [pleas contact you local supplier.



12.3.10 Message screen (main screen)

The joystick module displays warning icons and informational messages, in a dedicated message window.



12.3.10.1 Restart message

This icon is show when the system to be restarted. (most of the time when a module has been exchanged or added.)



12.3.10.2 Timer message

This symbol is displayed when the control system is changing between different states. An example would be entering into Programming Mode. The symbol is animated to show the sands falling.



12.3.10.3 Sleep message

This symbol will be displayed for a short time before the R-net enters a sleep state.



12.3.10.4 Joystick deflected message

This message is shown if the wheelchair is started up and the joystick is not in its zero position. If you let go of the joystick, the system will start up normally and the message disappears.



12.3.10.5 E-stop message

If the External Profile Switch is activated during drive, or actuator operation, this symbol will be displayed.



12.3.10.6 Error codes

If something is wrong with the wheelchair's electronics, the wheelchair will stop driving and an trip code (error code) will be displayed on the screen of the Joystick module.

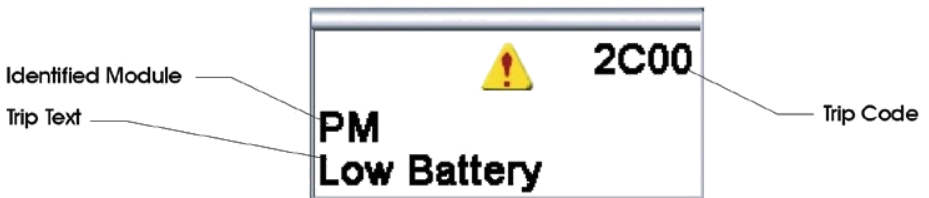

For more explanation about the trip code we refer to the chapter: trouble shooting.

12.3.11 Current profile (base bar)

The currently selected Profile is shown in numeric form.



12.3.12 Motor temperature (base bar)

This symbol is displayed when the control system has intentionally reduced the power to the motors, to protect them against heat damage.



12.3.13 Control system temperature (base bar)

This symbol is displayed when the control system has intentionally reduced its own power, to protect itself against heat damage.



12.3.14 Wheelchair lock

The wheelchair has the option so secure against unintended use. Therefore, the joystick module can be locked. This way it is protected against unintended use during storage or parking.

Lock options

The control system of the wheelchair can be locked in two ways: By using a button sequence on the keypad, or with a physical key. This key can be ordered as an accessory.

Keypad locking

To lock the wheelchair by using the keypad lock:

- While the wheelchair is switched on, depress and hold the ON/OFF button.
- After 1 second the control system will beep.
- Now release the ON/OFF button.
- Deflect the joystick forwards until the control system beeps.
- Deflect the joystick in reverse until the control system beeps.
- Release the joystick, there will be a long beep.
- The wheelchair is now locked.
- The following screen will be displayed in the control box:



wheelchair in locking mode

To unlock the wheelchair:

- If the control system has been switched off, press the ON/OFF button.
- Deflect the joystick forwards until the control system beeps.
- Deflect the joystick in reverse until the control system beeps.
- Release the joystick, there will be a long beep.
- The wheelchair is now unlocked.

Locking the wheelchair by using a physical key



To lock the wheelchair with the key lock:

- Insert and remove the supplied PGDT key into the charger socket.
- The wheelchair is now locked.

To unlock the wheelchair:

- Insert and remove the supplied PGDT key into the charger socket.
- The wheelchair is now unlocked.

12.4 Buttons

The joystick module has several buttons which will be explained below.



On/Off Button



Speed Buttons
Decrease / Increase



Horn Button



Mode Button



Profile Button



Hazard Button & LED



Lights Button & LED



Left Indicator Button & LED



Right Indicator Button & LED

12.4.1 On/off button

The On/Off button applies power to the control system electronics, which in turn supply power to the wheelchair's motors. Do not use the On/Off button to stop the wheelchair unless there is an emergency. (If you do, you may shorten the life of the wheelchair drive components).

CAUTION

Always make sure the wheelchair is switched off before entering or leaving the wheelchair. If the wheelchair is switched on during transferring, there is a danger the joystick will be touched and the wheelchair will move.

12.4.2 Horn button

The horn will sound while this button is depressed.

12.4.3 Speed decrease button

This button decreases the speed setting.

12.4.4 Speed increase button

This button increases the speed setting. (it does not increase the maximum speed!).

12.4.5 Mode button

The Mode button allows the user to navigate through the available operating modes for the control system. The available modes are dependent on programming and the range of auxiliary output devices connected to the control system.

12.4.6 Profile button

The Profile button allows the user to navigate through the available Profiles for the control system. The number of available Profiles is dependent on how the control system is programmed.

Depending on the way the control system has been programmed a momentary screen may be displayed when the button is pressed.

12.4.7 Hazard Warning Button and LED

This button activates and de-activates the wheelchair's hazard lights. Depress the button to turn the hazards on and depress the button again to turn them off.

When activated the hazard LED and the indicator LEDs will flash in sync with the wheelchair's indicators.

12.4.8 Lights Button and LED

This button activates and de-activates the wheelchair's lights. Depress the button to turn the lights on and depress the button again to turn them off.

When activated the lights LED will illuminate.

12.4.9 Left Indicator Button and LED

This button activates and de-activates the wheelchair's left indicator. Depress the button to turn the indicator on and depress the button again to turn it off.

When activated the left indicator LED will flash in sync with the wheelchair's indicator(s).

12.4.10 Right Indicator Button and LED

This button activates and de-activates the wheelchair's right indicator. Depress the button to turn the indicator on and depress the button again to turn it off.

When activated the right indicator LED will flash in sync with the wheelchair's indicator(s).

12.5 Jack sockets

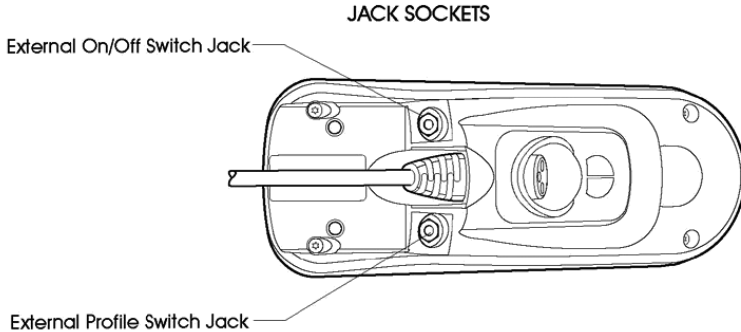

12.5.1 External profile switch jack

This allows the user to select Profiles using an external device, such as a buddy button. To change the Profile whilst driving simply press the button. If the control system is set to latched drive or actuator control operation, then the polarity of the jack input is reversed to affect a fail safe system; meaning this input will provide an External Profile Switch function and an Emergency Stop Switch function.

12.5.2 External on/off switch jack

This allows the user to turn the control system on and off using an external device, such as a buddy button.

i NOTE

The Joystick Module is supplied with rubber bungs that must be inserted into the Jack Socket when no external device is connected.

12.6 R-net Connectors

To connect the Communication Cables:

- Holding the connector housing, firmly push the connector into its mate until you can no longer see the yellow plastic.

The connectors are secured using a friction system.

To disconnect the Communication Cables:

- Holding the connector housing firmly, pull the connectors apart.

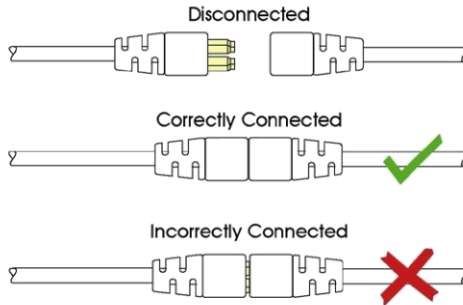

Do not hold or pull on the cable. Always grip the connector when connecting and disconnecting.

When the control system is first switched on after a connection, or system component change the Timer will be displayed whilst the system checks itself and then the re-start icon will be displayed. Switch the control system off and on again to operate.

CAUTION

If the communication is poor because of damaged cables, a trip code "bad cable" might be show on the display. Should this message appear on the display contact your local supplier to have the wheelchair checked.

12.7 Joystick

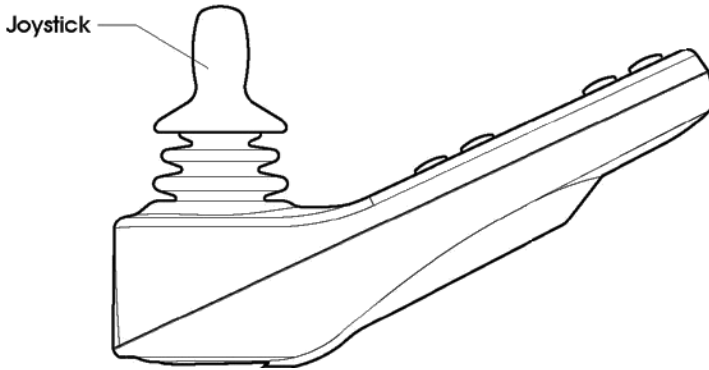

The joystick is primarily used to drive the wheelchair. just push the joystick into the direction you want to drive, and the wheelchair will start to move in that direction.

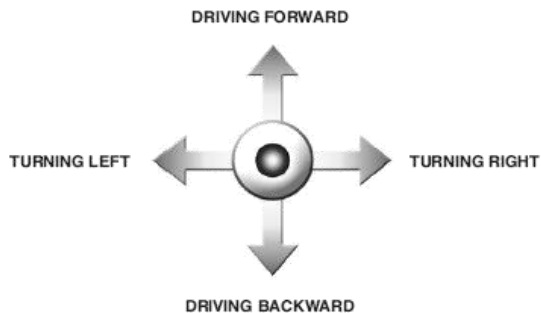

The secondary purpose of the joystick is to navigate through men menu of the wheelchair. By moving the joystick forward or backward you can scroll up or down through the menu, by moving to the right you can enter a sub selection.

CAUTION

We strongly recommend practicing the function of the joystick before starting to drive with the wheelchair.

13 Electric system

13.1 Batteries

The wheelchair has two serial-connected 12-volt maintenance free batteries for the power supply. The capacity of the batteries can be up to up to 80Ah. (actual sizes L:260 x W:168 x H:210 mm).

The batteries are fitted in the middle of the chassis to arrange a low center point of gravity. Both batteries are easily accessible for maintenance or replacement.



position and access of the maintenance free batteries

CAUTION

Be careful when using metal objects close to the batteries. A short circuit might easily create strong sparks and can cause a fire. Should you need to work on the batteries, use isolated tools and wear protective gear on hands and eyes.

CAUTION

Batteries are chemical components and shall be treated as such. In case of removal, one shall treat the batteries as chemical waste. The batteries need to be disposed according to the local regulations for chemical waste.

13.2 Fuse

The wheelchair has one main fuse to protect the batteries against overload and short circuit. This main fuse is easy to reach and placed on the right front cover of the wheelchair. The electronics itself is completely protected against short circuit and overload.

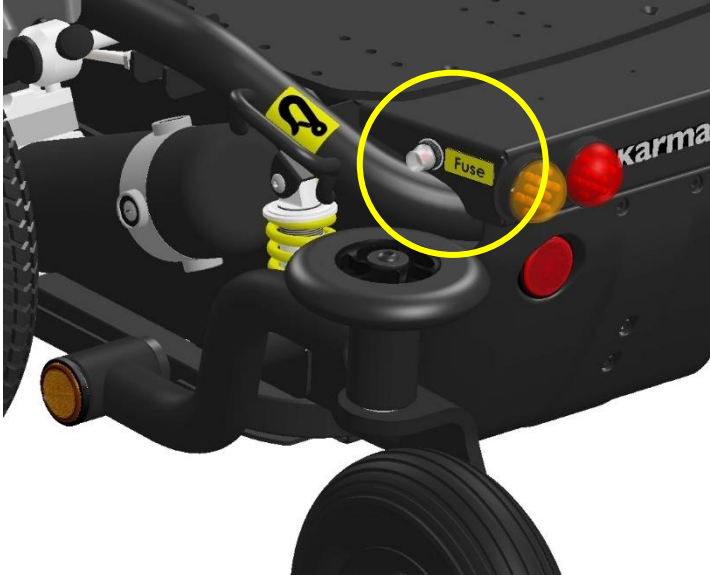

position of the main fuse

CAUTION

If the fuse is blown, please contact your local authorized supplier. He should check the wheelchair first before replacing the main fuse. The fuse only blows if a serious problem occurs.

CAUTION

Only use original spare part fuses of Karma. Using other fuses might damage the electronic system or even cause fire.

14 Using the wheelchair

14.1 General warnings and advices

Please read this section of the manual very carefully as it contains issues related to safety and possible hazards.

WARNING

- When the user is driving the wheelchair for the first time, the supplier has to make sure that the maximum driving speed and curving speed are set in a slow mode. After learning to drive the wheelchair safely, the set speeds can be increased.
- Special care should be taken in driving on unequal surfaces such as slopes, unequal pavements and during descending from footpaths.
- It is not allowed to carry passengers other than the user on the wheelchair.
- On slippery surfaces, like ice and snow, the driving speed must be reduced accordingly.
- Do not drive through water puddles, you cannot see how deep they are. This might lead to dangerous situations. Water can damage the wheelchair.
- Only charge the wheelchair in well ventilated areas.
- Note that no other persons or animals are in the direct contact zone of the wheelchair when using it. This is for both driving and using the high low. Because the wheelchair is a very powerful machine with a relative high weight this might lead to severe injuries.
- When driving the wheelchair in the dark, be sure that you have the lights switched on.
- Always drive slowly in the near surrounding of other people or animals.
- Although the wheelchair is intensively tested, it cannot be excluded completely that the wheelchair influences the performance of electromagnetic fields (e.g. Alarm systems of shops, automatic doors etc.).
- The driving characteristics of the wheelchair can be influenced by strong electromagnetic fields (e.g. Those emitted by portable telephones, electricity generators or high-power sources. Try to avoid the near presence of any radiation source such as radio's, cell phones etc. If your wheelchair reacts to a source of radiation with unexpected behavior, try to drive slowly to a safe place, turn off your wheelchair and try to extinguish the radiation source.

14.2 Use in combination with other products

Different- or customized seat:

WARNING

- The combination of seat and user does not exceed the maximum allowed weight on the wheelchair carrier and tilt mechanism (136 kgs).
- The seat is fixed properly to the seat post.
- The center of gravity of the combination of user and seat is on the same spot as when the standard seat would be used.
- The position of the tray table and/or the control unit is comfortable and easy to use for the user.
- The used materials are in compliance with the accepted standards mentioned in EN 12184 regarding flame resistance and biocompatibility.
- The seat or any other mounted parts do not touch the wheelchair carrier when using the high low function. Because the dimensions will vary from the standard seat. This has to be checked by watching these parts when activating the high low.
- The seat or any other mounted parts do not touch the wheelchair carrier when using the tilt function. Because the dimensions will vary from the standard seat. This has to be checked by watching these parts when tilting the chair.

WARNING

Changes which are made by third parties are not covered by the warranty and responsibility of Karma Medical.

14.3 Hot and cold surfaces

WARNING

Some parts of the wheelchair can reach high temperatures when exposed to direct sun. Please be careful with touching especially the plastic parts under these circumstances in order to prevent skin burning.

WARNING

The wheelchair can reach low temperatures when exposed to cold weather (below zero degrees Celsius). Please take caution in touching especially the metal parts with wet body parts under these circumstances as they easily can freeze and get stuck to these surfaces.

14.4 Danger of pinching

User

Special care has been taken to make sure that the chance that the user pinches him or herself while seated in the wheelchair is minimal. However, there are few situations that might lead to injury. Special caution has to be taken under the following circumstances;

- When the tray table is closed, pinching of fingers or other body parts is possible between the locking parts.
- When the revolving control unit is used in the tray table, pinching of fingers or other body parts is possible when the control unit is being turned upside down.
- When adjusting the seat while the user is sitting in the chair, please note that no body parts are in the direct zone of the moving parts.

WARNING

When moving the seat down, the tilt frame comes very close to the top chassis cover. This creates a pinching danger, when at this time, hands are on the top cover at the rear end of the chassis. For this reason a warning decal is placed on the top cover on the rear of the chassis. We advise you to always keep your hands or the hands from other persons away from the rear end of the top chassis cover.

WARNING

All areas where there might be a risk of pinching are indicated by these warning decal:

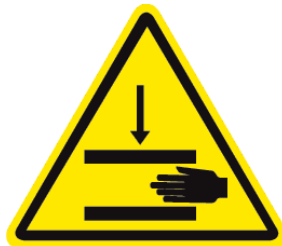

14.5 Surroundings

Special care has been taken to make sure that the change that the surroundings pinches him or herself is minimal. However, there are few situations that might lead to injury. Special caution has to be taken under the following circumstances;

- When driving the wheelchair, make sure that no persons or animals are in the near surrounding, because running over e.g. feet will lead to serious injury as a result of the high weight of the electrical wheelchair.
- When using the seat lift and/or the electrical tilt adjustment, make sure that no persons or animals are in the near surrounding, because it is possible to get pinched by the moving mechanism, although the moving parts are designed to be as safe as possible.

14.6 Precautions to prevent dangerous situations

In order to prevent dangerous situations please take note of the following precautions:

- Only charge the battery in well ventilated areas.
- Only drive at slow speed in the direct surrounding of other people or animals.
- Always turn on the head and rear lights when using the chair under circumstances with limited sight like darkness or fog.
- Please do not allow any persons to stand or sit on the wheelchair except for the user.
- Make sure that the remaining battery power is sufficient for the distance that is to be bridged.
- Do not replace a damaged fuse before it is known why the fuse is blown and the cause is taken away.
- Have the wheelchair checked by your supplier after any collision or when the wheelchair is otherwise (visual) damaged.
- Check the tire pressure and refill the tires, if necessary, every four weeks. Check the tires at the same time for wear and damage. Replace if necessary.
- Have the wheelchair checked on a yearly basis by your supplier.

- Do not change the programmed driving characteristics of your control unit, as it is specific for the situation of the user. If any adjustment is required because of a change of circumstances, please contact your supplier.

⚠ WARNING

Always make sure that, when positioned on slopes, the brakes are attached (no Freewheel). If the wheelchair is in freewheel mode, there is a risk that the wheelchair might start to move in an uncontrolled way. This might lead to personal or material damage.

14.7 Use on slopes: driving on downhill slopes

Driving on downhill slopes must always be done at a low speed and with great care. Avoid sudden braking, abrupt avoidance maneuvers and never maintain a speed higher than that at which you can maneuver the wheelchair in a safe and secure manner. Always be aware of the fact that the control of the wheelchair driving downhill is different than on level surfaces.



max. acceptable downhill slope

i NOTE

When driving on downhill slopes with an uneven or slippery surface (for example grass, gravel, sand, ice or snow) you should drive with extra care and attention.

i NOTE

When driving on downhill you can use the tilt (if build in) to create a more stable seating position for yourself.

⚠ WARNING

Never drive downhill on slopes bigger than 6°. This might result into uncontrollable behavior of the wheelchair. This can lead to material or personal damage. (Dynamic stability according to ISO 7176-2= 6°).

⚠ WARNING

The position of the seat in height and angle or the position of the backrest has great influence on the stability of the wheelchair when driving on slopes. Make sure the seat is in the optimal driving position to avoid tipping over.

⚠ WARNING

The position of the seat in height and angle or the position of the backrest has great influence on the stability of the wheelchair if driving on slopes. Make sure the seat is in the optimal driving position to avoid tipping over.

14.8 Use on slopes: driving on uphill slopes

Driving on uphill slopes must always be performed with great care and attention. Avoid sudden avoidance maneuvers and never drive at a speed higher than needed to maneuver the wheelchair in a safe and secure way. Avoid holes and bumps as much as possible. Drive slowly and controlled.



6°

max. acceptable uphill slope

i NOTE

When driving on uphill slopes with an uneven or slippery surface (for example grass, gravel, sand, ice or snow) you should drive with extra care and attention.

i NOTE

When driving on uphill you can use the tilt (if build in) to create a more stable seating position for yourself.

⚠ WARNING

Never drive uphill on slopes bigger than 6°. This might result into uncontrollable behavior of the wheelchair. This can lead to material or personal damage. (Dynamic stability according to ISO 7176-2= 6°.

⚠ WARNING

The position of the seat in height and angle or the position of the backrest has great influence on the stability of the wheelchair if driving on slopes. Make sure the seat is in the optimal driving position to avoid tipping over.

14.9 Driving on sideways slopes

Driving on a sideways slope must always be performed with great care. Avoid sudden avoidance maneuvers and never drive at a speed higher than needed to maneuver the wheelchair in a safe and secure way. Avoid holes and bumps as much as possible. Drive slowly and controlled.



driving on sideways slopes

i NOTE

When driving on sideways slopes with an uneven or slippery surface (for example grass, gravel, sand, ice or snow) you should drive with extra care and attention.

WARNING

Never drive sideways slopes bigger than 6°. This might result into uncontrollable behavior of the wheelchair. This can lead to material or personal damage. (Dynamic stability according to ISO 7176-2= 6°.)

WARNING

The position of the seat in height or the position of the backrest has great influence on the stability of the wheelchair if driving on slopes. Make sure the seat is in the optimal driving position to avoid tipping over.

14.10 Obstacle climbing

Do not drive the wheelchair over obstacles of a height bigger than 50mm. Driving over tall edges increases the risk of tipping over as well as the risk of damage to the wheelchair. Always be aware when climbing obstacles of the stability of your wheelchair.



Driving down of a higher surface (like pavement), Always be aware of the sudden forward movement of your wheelchair when driving down of it. If your wheelchair has powered seat tilt, you can use the seat tilt for more stability whilst driving of the pavement.

NOTE

When driving over obstacles with uneven or slippery surface (for example grass, gravel, sand, ice or snow) you should drive with extra care and attention.

WARNING

Never drive on obstacles higher than 50mm. Always drive with maximum attention and great care.

14.11 Use in presence of electromagnetic fields, e.g. from cell phones.

Use your cell phone only when the wheelchair is switched off. Although the wheelchair is tested and approved for electromagnetic interference, there is a very small change that strong electromagnetic fields from cell phones or some other electrical products lead to unexpected and unpredictable electrical reactions from the wheelchair.

Try to avoid the near presence of any radiation source such as radio's, cell phones etc. If your wheelchair reacts to a source of radiation with unexpected behavior, try to drive slowly to a safe place, turn off your wheelchair and try to extinguish the radiation source.

When it is unavoidable to use the wheelchair under these circumstances, be prepared for any unexpected and unpredictable electrical reactions from the wheelchair.

 **WARNING**

If you enter an area where there might a risk of strong electromagnetic interference, always reduce your driving speed and drive carefully.

 **WARNING**

Avoid area's where strong military transmitters are used. They might interfere with your wheelchairs electronics.

 **WARNING**

Avoid area's close to high voltage power lines. They might interfere with your wheelchairs electronics.

 **WARNING**

Avoid area's close to high frequency energy equipment, like high frequency welding machines. They might interfere with your wheelchairs electronics.

15 Driving the wheelchair

The wheelchair is designed for indoor and outdoor use. When driving indoors, you must be careful when driving in, for example, narrow passageways, when passing through doors and entryways as well as when using elevators, ramps, etc. Also be aware of the risk of things getting caught in the machinery when you use the electrical seat lift and seat tilt, in particular when the wheelchair has been run in under a table, workbench or something like that.

WARNING

Always make sure the wheelchair is switched off before entering or leaving the wheelchair. If the wheelchair is switched on during transferring, there is a danger the joystick will be touched and the wheelchair will move.

Outdoors, you must remember to drive very slowly on steep downhill slopes and to be very careful when driving on uneven surfaces, on uphill slopes, with sideways slopes and when negotiating obstacles. Always maintain a safe distance from the edge when driving close to drop-offs and pavements.

NOTE

We recommend that you should make repeated test drives in areas in which you know you feel secure so that you are quite familiar with how the wheelchair and its accessories behave in different situations before you begin using the wheelchair on normal roads and other public areas.

15.1 Driving in general

Make sure that the control system is mounted right, and that the joystick position is correct. The hand or limb you use to operate the joystick should be supported, for example by the wheelchair armrest. Do not use the joystick as the sole support for your hand or limb, the wheelchair movements and bumps could upset your control, which might result in uncontrolled driving.

1. Switch on the power by pressing the on/off button on the control panel.
2. Select the right profile (start with the indoor profile) Preferable to begin with a low driving speed.

WARNING

Always make sure the wheelchair is switched off before entering or leaving the wheelchair. If the wheelchair is switched on during transferring, there is a danger the joystick will be touched, and the wheelchair will move.

3. Set an appropriate maximum speed by pressing the decrease or increase button until the desired indicator lamp lights up for your type of driving. It is
4. Carefully move the joystick forward to drive forward, and backward to drive backward.
5. The speed of the wheelchair is adjusted continuously by the joystick being moved different distances forward and backward respectively. The wheelchair's electronics make creep driving possible over edges (max. 50mm.). You can drive up to the edge, and then carefully drive over it.

WARNING

Do not perform the first test drive on your own. The test drive is of course just a check of how you and the wheelchair function together, and you may need some assistance. Before driving, check that the wheel freewheel is set in the drive position.

15.2 Driving technique

The electronic control system of the wheelchair “reads” your joystick movements and transforms these “commands” into movements of the wheelchair. You will need very little concentration to control the wheelchair, which is especially useful if you are inexperienced. One popular technique is to simply point the joystick in the direction you want to go. The wheelchair will move in the direction you push the joystick. Always think about driving as flexibly and fluently as possible and avoid heavy braking and avoidance maneuvers. The smoother you move the joystick, the smoother the wheelchair will drive.

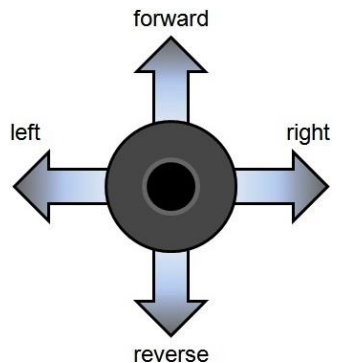

15.3 Stopping the wheelchair

If you would like to stop simply move the joystick slowly towards the center and release the joystick. The wheelchair will come to a gentle stop. If you want to stop more quickly, simply let go of the joystick. It will put itself back into neutral position, which makes the wheelchair stop. Is there an emergency situation and you need to make an emergency stop, pull the joystick backwards. This will slow down and stop the wheelchair very fast.

WARNING

Be careful driving backwards. You cannot really oversee where you are driving. It is better, when the space is available, to turn around and drive forward. By driving backwards not seeing where you are heading you might bump into something or someone. This can lead to personal or material damage.

WARNING

Be careful using the emergency brake. Especially when driving on slopes. Extreme braking might create the risk of tipping over when you are on a slope. Also, be aware that during braking you tend to lose balance yourself. If not strapped into a seat belt you might run the risk of falling out of your wheelchair whilst braking very hard.

16 Using the powered seat functions

If your wheelchair has powered seat functions like seat lift, seat tilt, backrest recline and/or powered legrest, you can control them by using the menu on the joystick module.

To enter the seat function menu, push the button "Mode" on the joystick module. You will leave the drive mode.



screen example of the seat function menu

By moving the joystick to the left or right you can switch between different powered seat function. One the required seat function is shown on the display, move the joystick forward or backward to activate the seat function in one direction. As long as you deflect the joystick from center the function will move. Release the joystick and the seat function movement will stop.

 **NOTE**

The acceleration and speed of each seat function can be programmed by your local authorized supplier. Should you request a different setting, please contact your local authorized supplier.

16.1 Using additional function of the wheelchair menu

If your wheelchair has additional function build in like the blue tooth mouse function, you can control this using the menu and joystick.

To enter the blue tooth mouse menu, push the button "Mode" on the joystick module. You will leave the driving mode. The first screen you will see is the powered seat function screen. If you push the "mode" button once more, you will enter the blue tooth screen. Now the joystick becomes the mouse for using the PC or laptop.

For further information about the additional options, we refer to your local authorized supplier.

17 Handling the mechanical brakes

The drive motors of the wheelchair have electromechanical brakes. The brake can be released to set the wheelchair into freewheel mode. In freewheel mode the wheelchair can be pushed. this might be necessary to move the wheelchair in certain cases.

17.1 Release the mechanical brakes

To release the mechanical brakes, take the following steps:

Look for the red lever on each side of the front battery-box.

Around the lever is an instruction sticker which shows the direction to open or lock the mechanical brake. Move the lever into the "open" position on each motor. Now the wheelchair is in freewheel mode and can be pushed.

To lock the brakes, move the lever in to the "lock" position on both motors.



NOTE

If you want to put the wheelchair into freewheel mode, be sure to switch the electronics first. Leaving the electronics switched on will result a large resistance whilst pushing in freewheel mode.

WARNING

If the parking brake is released (free-wheel mode), the wheelchair cannot be driven by the electronics. Therefore, the release of the brakes should only be done in emergency cases and or for servicing. If the user is on board, the parking brakes should always be attached.

WARNING

Always make sure that, when positioned on slopes, the brakes are attached (no Freewheel). If the wheelchair is in freewheel mode, there is a risk that the wheelchair might start to move in an uncontrolled way. This might lead to personal or material damage.

18 Charging the maintenance free batteries

The amount of charge in your maintenance free batteries is depending on a number of factors, including the way you use your wheelchair, the temperature of the maintenance free batteries, their age and the type of maintenance free batteries used. These factors will affect the distance you can travel in your wheelchair. All wheelchair maintenance free batteries will gradually lose their capacity when they get older. The most important factor that is reducing the life span of your batteries is the amount of charge you take from the batteries before you recharge them. The maintenance free battery life is also reduced by the number of times you charge and discharge the batteries. Normally the amount of cycles is between 300 and 700 times. To make your maintenance free batteries last longer, do not allow them to become completely discharged. Always recharge your maintenance free batteries promptly after they are discharged. If your battery gauge reading seems to fall more quickly than usual, your batteries may be worn out. If your wheelchair shows these indications, please contact your local authorized supplier to have the maintenance free batteries checked.

18.1 Battery level

The power level of the batteries is displayed on the LCD screen of the joystick module.



Battery indicator

If the maintenance free batteries are fully charged, all ten LED's on the top bar light up. The more energy is used the more LED extinguish, starting on the right side.

If only the red LED are still on, it indicates that recharging of the maintenance free batteries is required.

If only two red LED's are flashing, it indicates that the maintenance free batteries are empty and should be charged immediately.

i NOTE

If the battery indicator shows only two segments in flashing, you should charge the batteries as soon as possible. This flashing is a warning signal. You are still able to drive the wheelchair but only for a short distance. If the batteries reach a level where they cannot supply enough energy to control the wheelchair is a save way. The wheelchair will stop and give an error warning saying “low battery voltage”

i NOTE

If the batteries are drained completely, it is important that you charge them up again as soon as possible since a complete loss of charge reduces the lifespan of the batteries.

i NOTE

Information about the charger which is supplied with the wheelchair can be found in the user manual of the charger itself. You can find the charger user manual in the tool bag which comes with the wheelchair.

i NOTE

Some local dealers supply the wheelchair with their own brand of batteries and battery charger. For information about these batteries and charger, you should ask your local authorized supplier.

18.2 Charging socket

The charger socket can be found on the front side of the joystick module. If the wheelchair has an integrated desktop control, the charger socket will be on the side of the joystick module.



Charger socket position



Charger

The wheelchair can be delivered with a battery charger. This charger can have, depending on the supplied batteries, a capacity to charge up to 12 amperes. This charger will fully charge the batteries within 8 hours.

i NOTE

For more detailed information about the charger and its functions, we refer to the manual which comes with the charger. Charger can be supplied by your local dealer.

i NOTE

In some occasions putting in the charger socket yourself can be very difficult. Optionally, the wheelchair can be supplied with charger socket which can be placed on the spot you can reach yourself. For more information, please contact your local authorized supplier.

⚠ WARNING

Be sure that the charger plug is pushed fully in position. You will not be able to drive the wheelchair when the charger is connected. If the wheelchair does drive with the charger plugged in, contact your local authorized supplier.

i NOTE

In some occasions it might be the case that your local supplier will deliver the wheelchair with a different brand charger. In that case your local supplier will inform you about the functionality of that charger and will also make sure the charger comes with a user manual.

18.3 Disposal of broken or worn out batteries



Batteries don't last forever. Therefore, batteries need to be changed after a certain period. The safest way is to have this done by authorized personnel of your local supplier. Batteries are chemical waste and need to be treated as such, using protective clothing, gloves and glasses.

⚠ WARNING

Replacing damaged or old batteries needs to be done by authorized personnel wearing protective clothing, gloves and safety glasses.

⚠ WARNING

Old or damaged batteries are classified as chemical waste and need to be disposed according to the local regulations for chemical waste. Please contact your local supplier for further details.

19 Transport of the wheelchair

19.1 Transportation using Dahl Docking station

Leon FWD Versus has also been crash tested using a Dahl docking station tie down system according to ISO 7176-19:2008, where the wheelchair is facing forward in driving direction (driving direction like the driver seat)

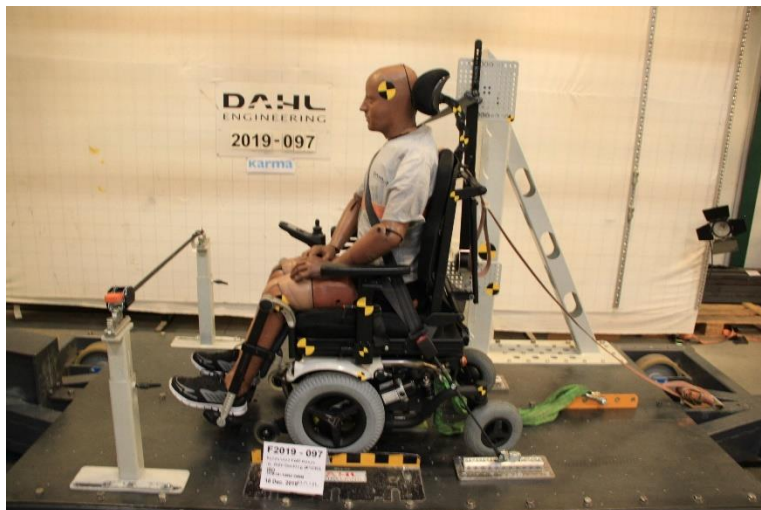

Leon FWD Versus crash test using Dahl Docking station.

The locking of the wheelchair into the Dahl Docking station makes it much easier to lock down the wheelchair for occupied transportation. It can be used also for wheelchair users who want to drive the car by themselves.

The system is self-locking and can be release by pushing a button. The locking device will open up for a certain time to make the un-docking possible.

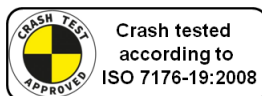

⚠ WARNING

The Dahl Docking station is only allowed to build into a vehicle by trained and authorized staff of a registered car adaptation company. For ordering the Dahl Docking and its accessories, please contact Dahl Engineering in Denmark for further details. You can find Dahl at www.dahlengineering.dk

19.1.1. Mounting of the Dahl locking adapter on the wheelchair

The Leon FWD chassis can be equipped with a Dahl docking plate underneath the battery box frame of the chassis.



Leon FWD chassis with Dahl Docking plate mounted.

For detailed information about the Dahl Docking system, please visit the homepage: www.dahlengineering.dk

To fit the Dahl docking plate, Karma has created a special kit for Leon FWD/RWD chassis which included the base mounting plate and two mounting bolts. This kit is available under Karma part no: 19170000061

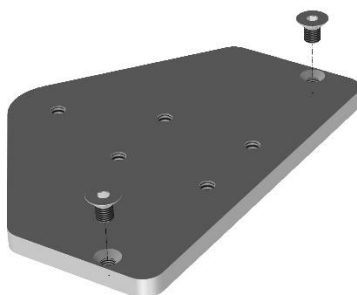

19170000061 Dahl Leon FWD / RWD mounting kit

WARNING

The Dahl Docking station is only allowed to build in to a vehicle by trained and authorized staff of a registered car adaptation company. For ordering the Dahl Docking and its accessories, please contact Dahl Engineering in Denmark for further details. You can find Dahl at www.dahlengineering.dk

To mount the Dahl locking plate on the Leon FWD chassis, take the following steps:



Step 1: remove the front cover bolts and lift the cover off by first tilting it.



Step 2: loosen the 4 locking bolts of the battery box.



Step 3: pull out the battery box and disconnect main battery cable.

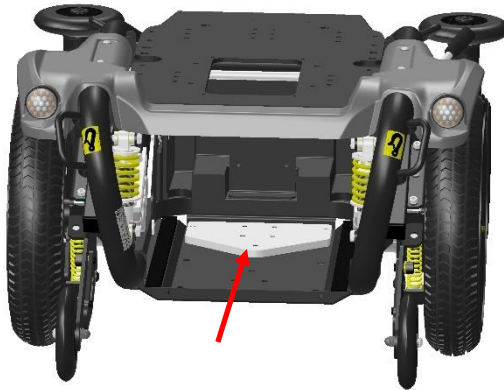

Step 4: place the mounting plate inside the chassis on the bottom

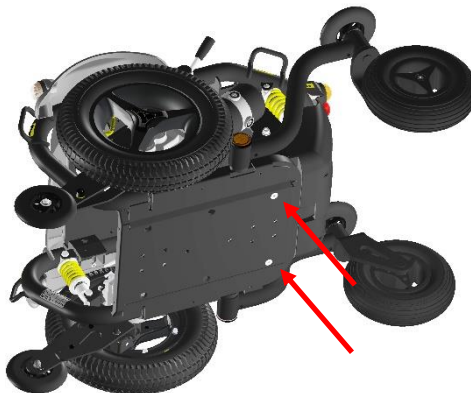

Step 5: tighten the two bolts into the mounting holes to fix the mounting plate.

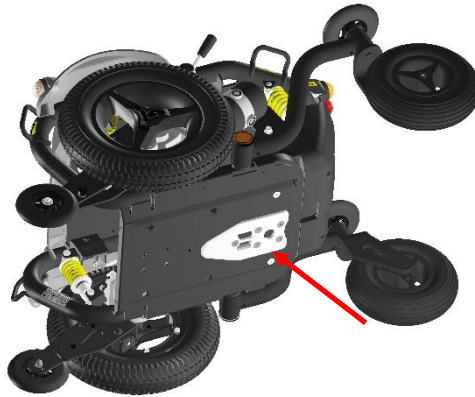

Step 6: mount the Dahl locking plate by using the 5 high grade Dahl bolts on to the chassis. Secure them with Loctite 222 and tighten them, but not too tight. (20-24Nm).

i NOTE

The special Dahl high grade Torx bolts (Dahl part no: 502800) only come in one length which often is too long. They need to be cut into the right length by the authorized engineer to fit the locking plate properly without damaging the batteries.

Step 7: Place the battery box back into the chassis and connect the batteries to the electronics.

Now, the Leon FWD chassis is ready to be docked into the Dahl Docking station.

Docking station in the vehicle:

The mounting of the Dahl docking station into your vehicle shall only be executed by an authorized car adaptation company. They will get the right support and information from Dahl Engineering how to mount the docking station into the designated vehicle.



Dahl Docking set

⚠ WARNING

The Dahl Docking station is only allowed to build in to a vehicle by trained and authorized staff of a registered car adaptation company. For ordering the Dahl Docking and its accessories, please contact Dahl Engineering in Denmark for further details. You can find Dahl at www.dahlengineering.dk



Dahl docking station



Dahl docking station mounted on the floor



Docking station and docking plate on chassis

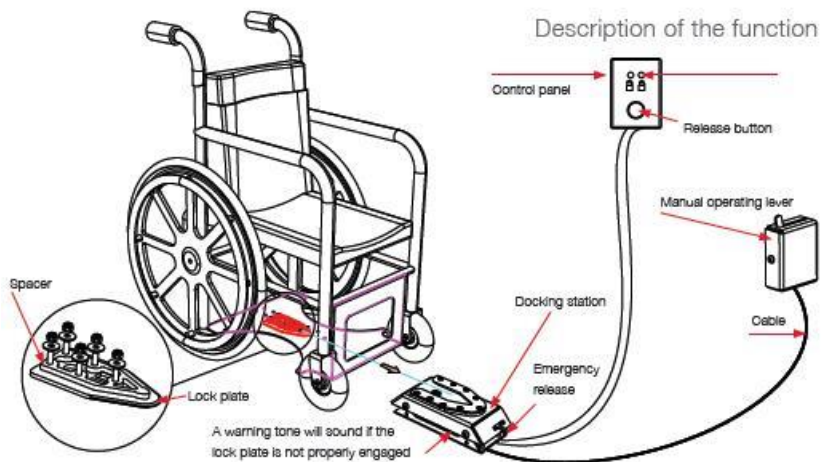

19.1.2. Locking procedure

Drive the wheelchair slowly into the vehicle and make sure you center your wheelchair in the middle of the docking module. If being well positioned the locking system will also guide the wheelchair into the docking station. Keep in slowly driving until you feel the wheelchair is hitting the end position in the docking station. At the same time, you will hear a clicking sound. The wheelchair is now locked into the docking station. The light on the control panel will light up de LED showing the wheelchair is locked in correctly. Now switch the wheelchair off.

WARNING

If the wheelchair is not centered correctly, it might not be possible to lock in top the docking station. In that case, retry by driving a bit backwards and re-center the wheelchair. Try once more until you hear the clicking sound and you see the locked sign LED on.

After the wheelchair is locked in, put the car safety belt on according to the instruction in chapter 19.1.5.

NOTE

The positioning belt is not to be used as a safely belt. If the wheelchair is transported in an occupied position, the user needs to wear a safety belt which is mounted in the vehicle he or she is transported in. Additionally, we strongly advice to keep the positioning belt strapped as well as it secures you position in the seat. A car safety belt doesn't fulfil that support. So, use both and you are safe and positioned.

WARNING

Do not forget to put the car safety belts on before driving in the vehicle. This on order to avoid dangerous situations and personal- or wheelchair damage.

19.1.3. Unlocking procedure

To unlock the wheelchair, first open up the car safety belt. Then switch on the wheelchair and switch to drive mode. Now push the release button of the Dahl Docking station. You will hear a firm click. The locking bolt is now retracted, and the wheelchair can drive in reverse direction out of the Docking station.

NOTE

After pushing the release button of the Dahl Docking station, the locking bolt is retracted for a certain period of time. After that time, the bolt will lift up again and lock the Docking station. Make sure you drive your wheelchair out of the Docking station in this time window of the unlocked position. If not, you have to push the release button one more time.

19.1.4. Manually unlocking in case of electric failure or accident

The Dahl Docking station can be unlocked manually in case of an emergency or if the electric unlocking is failing.

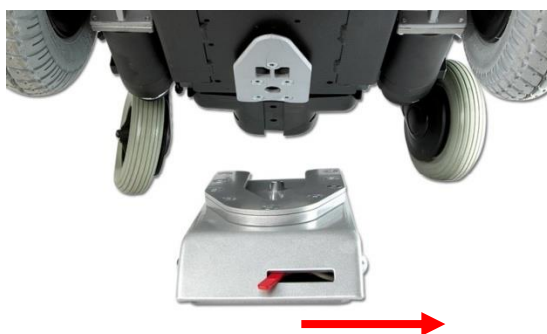

To unlock the docking station manually, the red lever needs to be pulled to the right. This retracts the locking bolt manually so the wheelchair can be released out of the docking station.

WARNING

In case of a failure of the docking station, contact your local car adaptation company who has built in the device into your vehicle. Only authorized and trained staff is allowed to work on the docking device.

19.1.5. Safety belt

If the user is transported in his wheelchair, it is necessary to use a car safety belt to secure the wheelchair user.

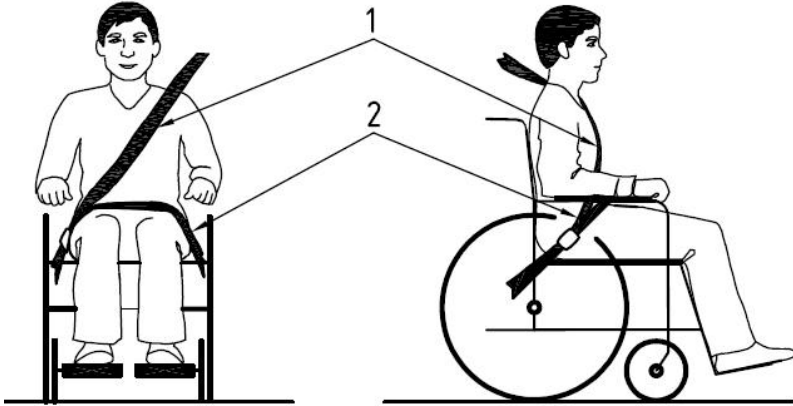

Positioning of the car safety belts for wheelchair users.

The wheelchair has been crash tested using a Dahl 3-point occupant safety belt, model 500984. We advise you to use a similar system or a system that is equally specified. It is very important to use the safety belt in the right angles according to the wheelchair user. The angle for the pelvis part (2) of the safety belt must be in angle of 30- 75 ° with the horizontal plane. (See picture below). Also, the side angle should stay between the vertical plane to maximum of 15° angle with the vertical plane. (See picture below).

i NOTE

The positioning belt is not to be used as a safety belt. If the wheelchair is transported in an occupied position, the user needs to wear a safety belt which is mounted in the vehicle he or she is transported in.

Additionally, we strongly advice to keep the positioning belt strapped as well as it secures you position in the seat. A car safety belt doesn't fulfil that support. So, use both and you are safe and positioned.

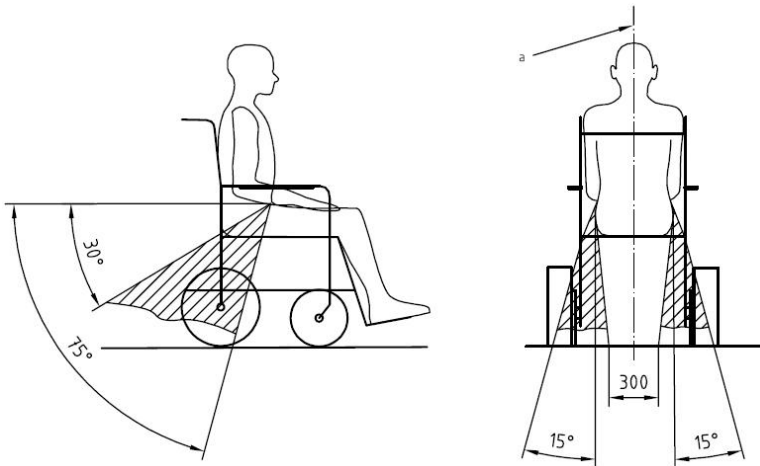

Optimal angles for a safety belt used by the wheelchair user

The shoulder part (1) of the safety belt should be positioned according to the figure below.

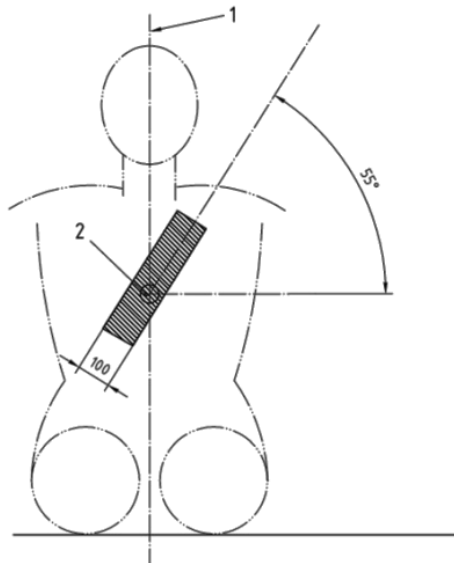

Shoulder safety belt positioning

i NOTE

Please obtain the following points for an optimal personal safety of the wheelchair user:

- the pelvic belt should be worn low across the front of the pelvis, so that the angle of the pelvic belt is within the preferred zone of 30° to 75° to the horizontal, as shown in figure above.
- a steeper (greater) angle within the preferred zone is desirable.
- belt restraints should not be held away from the body by wheelchair components or parts, such as the wheelchair armrests or wheels, along with an illustration similar to that of the figure shown above.
- upper torso belts should fit over the shoulder and across the chest, as illustrated in figure of the shoulder safety belt positioning.
- belt restraints should be adjusted as tightly as possible, consistent with user comfort.
- belt webbing should not be twisted when in use.

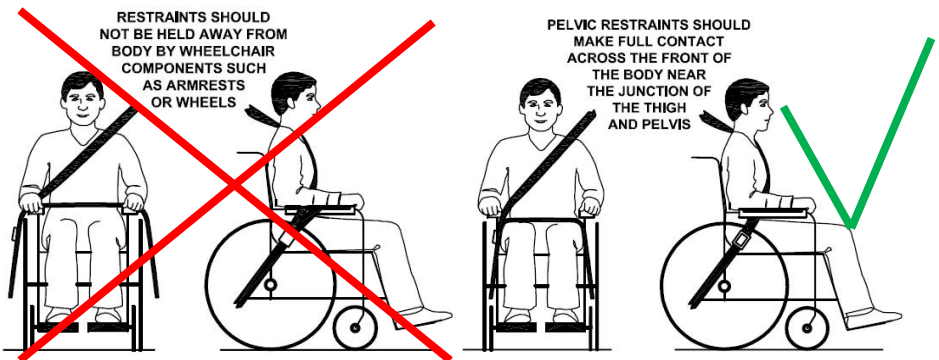

Picture of improper belt fit

Picture of proper belt fit

**NOTE**

Please, make sure the following conditions are fulfilled to obtain a safe transportation:

- Whenever possible the occupied wheelchair shall be located in a forward-facing configuration and secured by the tie downs in accordance with the WTORS (wheelchair tie down and occupant-restraint system) manufacturer's instructions.**
- This wheelchair is suitable for use in vehicles and has met the performance requirements for travelling forwards-facing in frontal impact conditions. Its use in other configurations within a vehicle has not been tested.**
- The wheelchair has been dynamically tested in a forward-facing orientation with the ATD (anthropomorphic test device) restrained by both pelvic and upper torso belts.**
- Both pelvic and upper torso belts should be used to reduce the possibility of head and chest impacts with vehicle components.**
- When possible, other auxiliary wheelchair equipment should be either secured to the wheelchair or removed from the wheelchair and secured in the vehicle during transit, so that it does not break free and cause injury to vehicle occupants in the event of a collision.**
- Positioning supports should not be relied on for occupant restraint in a moving vehicle unless they are labeled as being in accordance with the requirements specified in ISO 7176/19-2008.**
- The wheelchair should be inspected by a manufacturer's representative before reuse following involvement in any type of vehicle impact.**

19.2 4-point Tie-down belts

The Leon FWD Versus complies with the requirements specified in ISO 7176-19:2008. It has been designed and tested according to the ISO 7176-19:2008, for transportation in a occupied position, forward facing in a vehicle.

The wheelchair is designed to use a 4-point heavy duty webbing restraint. For this matter the wheelchair has two brackets on the front end and two brackets on each rear side of the chassis. The brackets are indicated with a sticker. These anchoring point shall be used to connect the tie-down belt to.



For the tie down belt we advise to use a Dahl heavy duty tie-down belt, model 501780 or 501781. The angle of the straps should be around 45° to the horizontal plane. This is in order to have maximum effect in vertical and horizontal direction.



The straps have to be connected to the vehicle at suitable anchor points. Make sure that the tire pressure is at the recommended level so the straps can have maximum effect. Make sure the straps are tightened to maintain optimal security.

 **WARNING**

Poor fixations of the wheelchair in a vehicle might cause damage to the vehicle itself, the wheelchair or the passengers inside the vehicle while driving. Not using a car safety belt while sitting in a wheelchair might lead to serious injuries in case of an accident.

 **NOTE**

The access to, and maneuverability in, motor vehicles can be significantly affected by wheelchair size and turning radius. Smaller wheelchairs and/or wheelchairs with a shorter turning radius will generally provide greater ease of vehicle access and maneuverability to a forward-facing position in the vehicle. Also, the internal size of the vehicle will have a great influence of the maneuverability into and out of the vehicle. Make sure there are loose object inside the vehicle which might make entering en positioning inside the vehicle more complicated.

 **NOTE**

Although the wheelchair is designed and tested according to the ISO 7176-19:2008 requirements, we also advice: wheelchair users should transfer to the vehicle seat and use the vehicle-manufacturer-installed restraint systems whenever it is feasible, and the unoccupied wheelchair should be stored in a cargo area or secured in the vehicle during travel.

 **NOTE**

For more information, tie down kits for vehicles and or further information about tie-down belt and occupant 3-point safety belt, please visit the website of Dahl engineering at www.dahlengineering.dk

 **WARNING**

Postural supports should not be relied on for occupant restraint in a moving vehicle, unless they are labelled as being in accordance with the requirements specified in ISO 7176-19:2008,

19.2.1 Safety belt:

If the user is transported in his wheelchair, it is necessary to use a car safety belt to secure the wheelchair user.

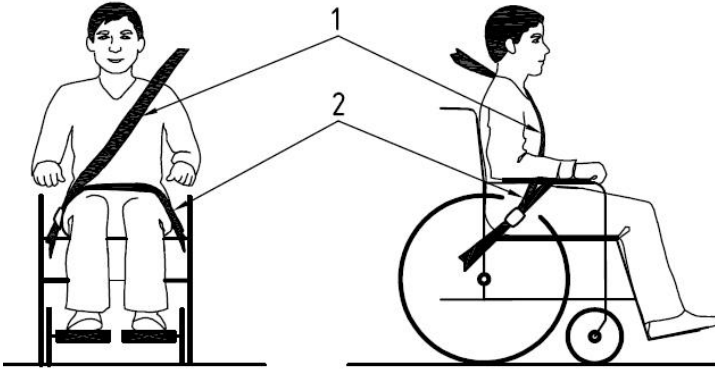

positioning of the car safety belts for wheelchair users.

The wheelchair has been crash tested using tie down belts, and a 3-point occupant safety belt. We advise you to use a Dahl 3-point occupant safety belt model 500984 system or a system that is equally specified. It is very important to use the safety belt in the right angles according to the wheelchair user. The angle for the pelvis part (2) of the safety belt must be in angle of 30- 75 ° with the horizontal plane. (see picture below). Also, the side angle should stay between the vertical plane to maximum of 15° angle with the vertical plane. (see picture below).

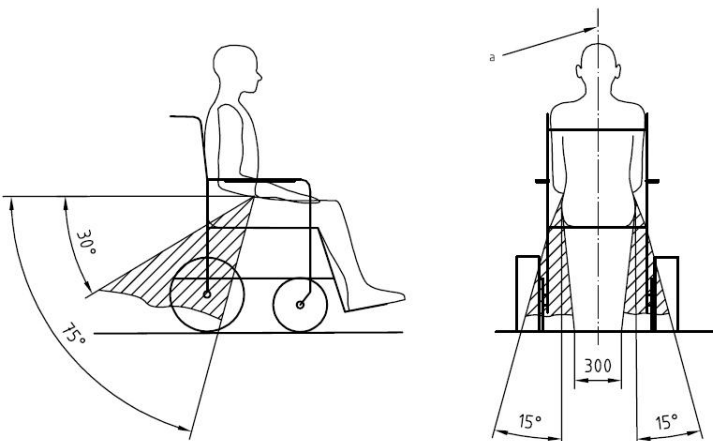

optimal angles for a safety belt used by the wheelchair user

The shoulder part (1) of the safety belt should be positioned according to the figure below.

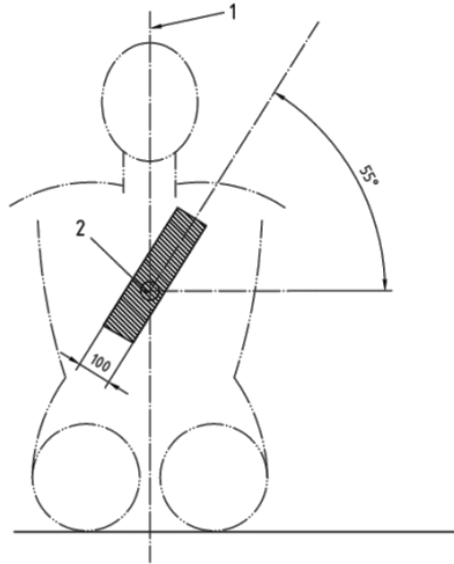

shoulder safety belt positioning



NOTE

Please obtain the following points for a optimal personal safety of the wheelchair user:

- the pelvic belt should be worn low across the front of the pelvis, so that the angle of the pelvic belt is within the preferred zone of 30° to 75° to the horizontal, as shown in figure above.
- a steeper (greater) angle within the preferred zone is desirable.
- belt restraints should not be held away from the body by wheelchair components or parts, such as the wheelchair armrests or wheels, along with an illustration similar to that of the figure shown above.
- upper torso belts should fit over the shoulder and across the chest, as illustrated in figure of the shoulder safety belt positioning.
- belt restraints should be adjusted as tightly as possible, consistent with user comfort.
- belt webbing should not be twisted when in use.

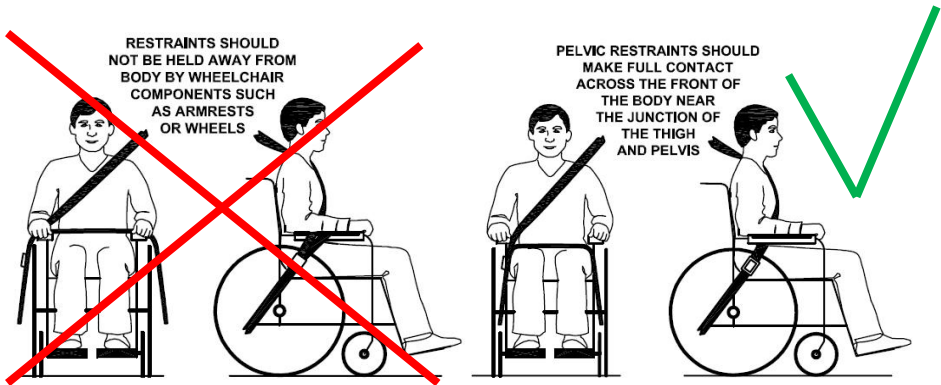

i NOTE

Please, make sure the following conditions are fulfilled to obtain a safe transportation:

- Whenever possible the occupied wheelchair shall be located in a forward-facing configuration and secured by the tie downs in accordance with the WTORS (wheelchair tie down and occupant-restraint system) manufacturer’s instructions.
- This wheelchair is suitable for use in vehicles and has met the performance requirements for travelling forwards-facing in frontal impact conditions. Its use in other configurations within a vehicle has not been tested.
- The wheelchair has been dynamically tested in a forward-facing orientation with the ATD (anthropomorphic test device) restrained by both pelvic and upper torso belts.
- Both pelvic and upper torso belts should be used to reduce the possibility of head and chest impacts with vehicle components.
- When possible, other auxiliary wheelchair equipment should be either secured to the wheelchair or removed from the wheelchair and secured in the vehicle during transit, so that it does not break free and cause injury to vehicle occupants in the event of a collision.
- Positioning supports should not be relied on for occupant restraint in a moving vehicle unless they are labeled as being in accordance with the requirements specified in ISO 7176-19-2008.
- The wheelchair should be inspected by a manufacturer’s representative before reuse following involvement in any type of vehicle impact.

i NOTE

- Alterations or substitutions should not be made to the wheelchair securement points or to structural and frame parts or components without consulting the manufacturer.
- Only use "gelled electrolyte" batteries on powered wheelchairs when used in a car.

⚠ WARNING

special care should be taken when applying the occupant restraint to position the seatbelt buckle so that the release button will not be contacted by wheelchair components during a crash.

19.2.2 Backrest, legrest and headrest settings during transportation.

During transportation in an occupied position, the backrest of the wheelchair needs to be set into an upright position. The legrest should be in a knee angle close to 90 degrees. The headrest needs to be adjusted well so it will catch the head of the wheelchair user during the rebound of an impact, this to reduce the risk of a whiplash.



recommended position of the backrest, legrest and headrest

9.3 Transportation on an airplane

When transporting your wheelchair by air, you should primarily pay attention to the following in below:

19.3.1. Batteries

Gel batteries: In most cases, they do not need to be removed from the wheelchair. The batteries only need to be disconnected from the wheelchair. To do this simply disconnect one of the battery pole connectors.



position of the battery pole (behind the black cover)

Acid batteries: Most airlines require that batteries be removed from the wheelchair and transported in special boxes that the airline may provide.

When transported by air, the wheelchair will be put with other goods in a confined space. Therefore, it is important to take preventive action to minimize transport damage to the wheelchair. Cover the control panel with soft, shock-absorbing material (foam plastic or similar) and fold it in towards the back rest. Protect other protruding objects in a similar manner. Tape any loose cables to the seat or covers.

19.3.2. The wheelchair's dimensions and weight

How much the wheelchair weighs and how large it is are important, depending on the type of airplane in which the wheelchair is to be transported. The smaller the airplane is, the smaller the wheelchair may be/weigh and vice versa. Always check with the airline what rules apply.

20. Maintenance and repairs

The user and attendant have to take care of some maintenance, service and occasionally fault-finding activities. Other activities as described in this paragraph should be carried out under supervision of your authorized dealer.

20.1 Battery charging

This wheelchair is provided with two maintenance free batteries. During normal use, the batteries must be charged every day. It is most convenient to make it a daily practice to charge the wheelchair during the night.



NOTE

- Only charge in a well-ventilated room with no sources of open fire.
- Turn of the control unit before charging
- Make sure the charging cable is not causing crashes of people
- When the charger is disconnected from the wheelchair, also disconnect the charger from the mains.
- Place the charger in a place where it can radiate its heat freely during charging

After having taken care of these precautions, charge the batteries by plugging in the charger in the rear of the control unit first. Plug in the charger in the mains secondly. Read the manual of your charger carefully for any other precautions and user prescriptions. When the wheelchair is not used over a longer period, recharge the batteries every four weeks to keep the batteries in good condition. If the batteries are not charged regularly, the remaining capacity will quickly drop.

20.2 Short term storage

For the charging process to produce a battery with good capacity, the temperature in the storage room should not be lower than +5 degrees. If it is stored at a temperature below +5 degrees, there is a higher risk that the battery has not been fully charged when it comes to be used and also a higher risk of corrosion.

20.3 Long term storage

The battery may be stored in an unheated room, but it should be charged at least once a month for maintenance purposes.

NOTE

When the wheelchair is stored for a long term, we advise you to disconnect the batteries from the wheelchair. This way the batteries will hold their energy for a longer period.

When re-using the wheelchair, the batteries will be installed and fully charged.

Ask your local authorized supplier to store and maintain the batteries if they are not used for a long period (more than two months.)

NOTE

- Please note that a battery discharges itself and that a discharged battery can burst when it is cold. If the wheelchair is to be stored unused for an extended period of time, the batteries must always be charged once a month to avoid them being damaged.

- The wheelchair must not be stored in areas subject to condensation (steam or moisture on surfaces), for example utility rooms or similar.

- The wheelchair may be stored in an unheated room. From the point of view of corrosion, it is best for the room to be a few degrees warmer than the surroundings as this keeps the room drier.

- If the wheelchair is fitted with acid batteries, the acid level should be checked regularly. If the wheelchair is fitted with gel batteries, the liquid level does not need to be checked.

- The life of the batteries depends entirely on regular charging.

WARNING

Be careful when using metal objects close to the batteries. A short circuit might easily create strong sparks and can cause a fire. Should you need to work on the batteries, use isolated tools and wear protective gear on hands and eyes.

20.4 Tools

The wheelchair comes with a tool kit to be able to adjust most settings.



i NOTE

Some repairs may require tools other than those supplied with the wheelchair.

⚠ WARNING

The main fuse must always be removed when batteries are replaced. Always switch off the power supply to the control panel before interrupting the power with the main fuse.

i NOTE

Any unauthorized alterations to the wheelchair and its systems may lead to an increased risk of accident. All alterations to and interventions in the wheelchair's vital systems must be performed by an authorized service engineer. In case of doubt, always contact an authorized service engineer.

⚠ WARNING

Damage caused by self servicing or servicing by unauthorized personnel cannot be claimed under warranty!

If you have any doubt in the capability of yourself or the service engineer, please contact your local authorized supplier to help you.

20.5 Wheels and tires

Check at regular intervals that the wheelchair's tires have the correct tire pressure.

Check regularly that the tire pressure is okay. We suggest checking the tire pressure at least every 4 weeks.

Type of tire	Tire size	Recomm. pressure
Front tire	3.00-8	43 PSI, 3 Bar, 300 Kpa
Rear tire	2.80/2.50 - 4	29 PSI, 2 Bar, 200 Kpa

WARNING

An incorrect tire pressure may result in lower stability and maneuverability. Too low tire pressure also results in abnormal wear and shorter driving range.

20.5.1 Puncture repair

Since the wheelchair is rather heavy, it is recommended to let your authorized supplier repair eventual tire punctures. First lift the wheelchair so that the punctured tire is free from the ground. The front wheel tires can be taken off by loosening the 3 bolts (B) which hold the wheels on to the wheelchair. **DO NOT LOOSEN THE CENTER BOLT (C).**

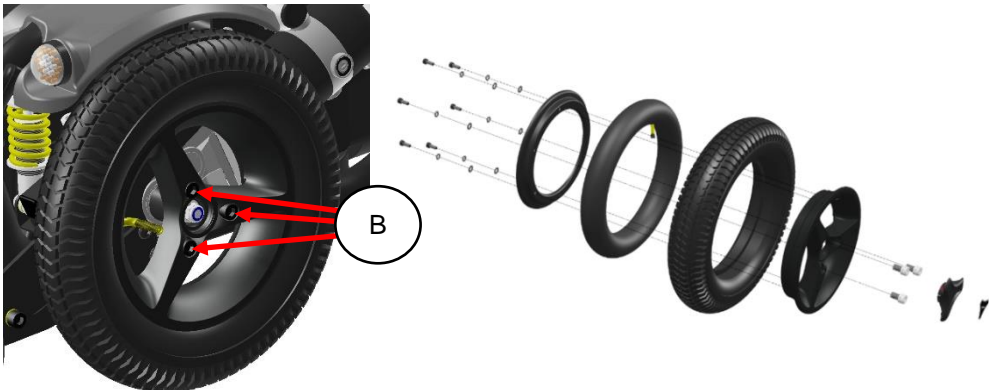

Exploded view of (drive) wheel

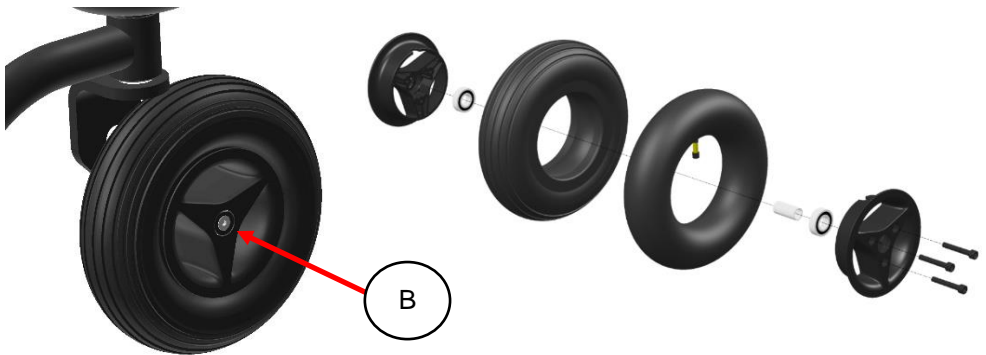

The rear wheel can be taken off by loosening the center bolt.

After taking the wheels of the wheelchair the rim can be split. The tire is then available for repair. The inner tubes of the tires can be repaired according to the description on the tire puncture repair kit that you use. It is however recommended to renew the inner tube at all time when the tube has a puncture.

i NOTE

After re-assembling the wheel, you should mount the wheel onto the motor or rear fork and secure the bolts with blue loctite.

20.6 Cleaning

Regular care and maintenance will prevent unnecessary wear and damage to your wheelchair. The following is general advice recommended by Karma. For severe soiling of the upholstery or damage to the surface finish, contact Karma or your local authorized supplier for information.

20.6.1 Upholstery, cloth / 3D mesh

For normal cleaning, wash the upholstery with hand warm water and a mild nonabrasive soap. Use a soft cloth or brush. Before the surface dries, wipe off any water/soap residues with a clean, dry cloth. This procedure may be repeated to remove stubborn dirt or stains.

If necessary, the cover may be removed before cleaning. See also the washing instructions on the label of the upholstery materials.

20.6.2 Metal surfaces

For normal cleaning it is best to use a soft cloth/sponge, hand warm water and a mild detergent. Wipe down carefully with a cloth and water and dry off.

Remove scuff marks from semi-matt surfaces with soft wax (follow manufacturer's instructions).

Remove scuff marks and scratches from shiny surfaces using car polish, either liquid or paste. After polishing, apply soft car wax to restore the original surface gloss.

20.6.3 Plastic covers

For normal cleaning, wash plastic surfaces with a soft cloth, mild detergent and hand warm water. Rinse thoroughly and dry with a soft cloth. Do not use solvents or abrasive kitchen cleaners.

WARNING

Never use aggressive chemical cleaner or cleaning fluids. These will damage the surface and structure of the material.

WARNING

Never use a high pressure water hose or steam cleaner. This will damage the surface and structure of the material and could cause electronic failure.

WARNING

Never use a sponge with a hard surface. This will damage the surface and structure of the material.

20.7 Brake release, freewheel mode

Check regularly, approximately once a month, that the brake release and the brake release lever is working properly.

When the brakes are released, it should not be possible to drive the wheelchair.

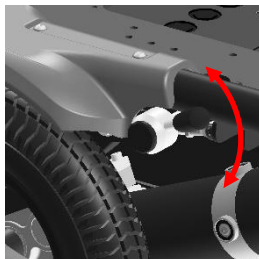

Testing the brake release

20.8 Battery replacement

Karma strongly recommends that battery replacement and installation always be done by a qualified technician. To replace the batteries, please refer to the photos below of the batteries equipped on the Leon series, and follow the below instructions to remove and load the batteries. The weight of one battery could be more than 10 kg. Please handle it with care.

WARNING

Do turn off the power of the wheelchair before replacing or loading the batteries.

Do NOT allow conductive material such as a wrench to contact BOTH battery terminals at the same time. This will result in a short that can cause burns to you and damage the battery.

Most batteries are not sold with instructions. However, warnings are frequently noted on top of the batteries. Read them carefully.

Do NOT allow the liquid in the battery to come in contact with skin, clothes or other items. It is a form of acid and may cause harmful or damaging burns. Should the liquid come into contact with skin, rinse the area immediately and thoroughly with cool water. If liquid comes into contact with eyes, flush eyes immediately and seek medical attention as soon as possible.

The use of rubber gloves and chemical goggles are recommended when working with batteries.

NEVER smoke or strike a match near the batteries.

Replace the batteries IMMEDIATELY if there are any cracks or leaks.

20.8.1. Replacing the batteries

Step 1: remove the two screws on the battery casing in the front of the wheelchair and lift it off.



removing the cover bolts

Step 2: remove the four battery box locking bolts at the rear end of the chassis side.



removing the locking bolts

Step 3: Pull the battery box slowly out of the chassis, mind the cables.

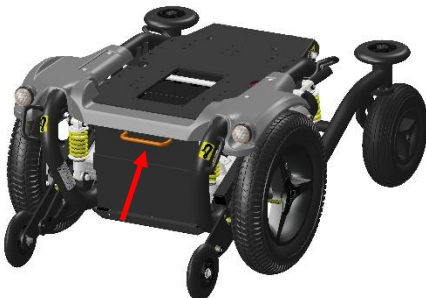

grabbing the grip



pulling out the battery box

Step 4: Unplug the battery cable connectors.



unplugging the cables

Step 5: lift the batteries out of the box and disconnect the cables of the poles using a wrench

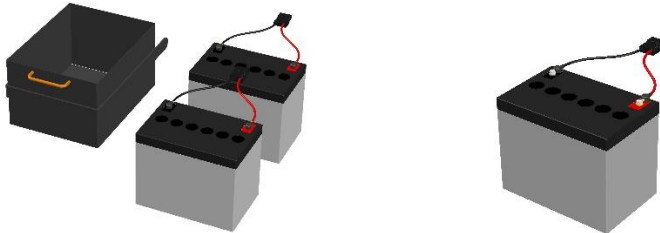

lifting out the batteries

disconnect the cable from the battery poles

 **WARNING**

Although the batteries may be broken, still be very careful when touching the battery connection poles. Avoid any risk of short circuit between both poles.

Step 6: take the new batteries and place in the battery box.

Step 7: connect the cables on to the poles.

Step 8: place the battery box in front of the chassis.

Step 9: connect the cables to the main power cable of the chassis.

Step 10: lift the battery box into the chassis and slide it slowly into the chassis



placing the battery box into chassis and slowly slide in inside

Step 11: fixate the battery box by attaching the four locking bolts at the rear of the chassis.



Step 12: place the front cover back and secure it with the two bolts

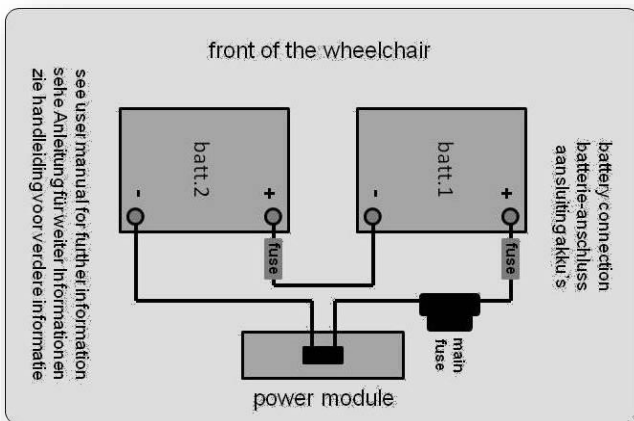

battery wiring

20.8.2 disposal of the batteries.

WARNING

There are many risks involved with improper disposal of batteries, whether damaged or not. Batteries may contain heavy metals and be considered hazardous waste.

Many regions around the world now strictly enforce laws to help protect our environment. By not disposing of batteries properly, you may be liable for fines from your local through national government.

By not recycling batteries, they end up in landfills where lead and other chemicals may leach into streams and rivers destroying ecosystems and poisoning local water resources.

Improper disposal of batteries may also cause injury to unsuspecting others that come in contact with them. If you come in contact with fluids or corroded powder from a battery, rinse with water and contact a physician if necessary. If contact with eyes occurs, rinse for 15 minutes and then visit a physician.

DO NOT incinerate or burn the battery. It will cause it to explode!

Please see the chapter of: Disposal of the product

WARNING

If you are not capable of replacing the batteries by yourself or you don't feel comfortable doing it, please contact your local authorized supplier for help.

WARNING

Damage on the wheelchair as a result of a not proper repair or replacement is not covered by our product warranty.

WARNING

Batteries are classified as chemical waste and need to be disposed according to the local regulations for chemical waste.

21 Refurbishment and re-use of the product.

This wheelchair is suitable for refurbishment and re-use. This means that, if the wheelchair is not used anymore by the first user, it can be refurbished to fit another user. Should you not be able to use the wheelchair any longer, we strongly recommend you contact your local authorized supplier to have it picked up for refurbishment and re-use.

WARNING

the refurbishment of the wheelchair is only allowed to be executed by an authorized supplier.

WARNING

If the wheelchair is refurbished by a non-authorized supplier or institute, Karma Medical cannot be held responsible for this product, and all warranty claims will be voided.

NOTE

The wheelchair will be refurbished according to a refurbishment guideline of Karma. This includes the replacement of all upholstery parts, a total disinfection of the product and a complete technical check of the wheelchair and its accessories.

22 Disposal of the product

In the case of disposal of the used wheelchair you need to follow the local legal regulations for disposals.

We strongly recommend you contact your local authorized supplier to take care of the disposal of your wheelchair.

WARNING

Batteries are classified as chemical waste and need to be disposed according to the local regulations for chemical waste.

23 Trouble shooting

The following troubleshooting guide describes a number of faults and events which may occur when you use your wheelchair, together with suggested remedies. Note that this guide cannot describe all the problems and events which may occur, and you should always contact your local authorized supplier or Karma in case of doubt.

Event	Possible Cause	Remedy
The wheelchair does not start up	Batteries discharged.	Charge the batteries
	The cable connection of the control panel has come loose	Reconnect the cable
	Main fuse is defect	Replace main fuse Check first!!! See page 105
Wheelchair doesn't drive	Charge still connected	Disconnect charger
	Brake release activated	De-activate brake release
	Wheelchair locked	Unlock the wheelchair
The wheelchair switches itself on after a certain while	The energy saving mode has been activated	Restart wheelchair using the on/off button
The wheelchair stops whist being driven	A cable connection of the R-net system has come loose	Check all R-net connections and restart
	Main fuse has triggered	Replace main fuse Check first!!! See page 105
The wheelchair only drive at reduced speed	A speed reducing inhibit is activated	Move the seat into a position where max. Speed is allowed.
	Gyro has been disconnected	Re-connect gyro Need service!!
Certain powered seat function is not displayed in menu	Cable connection of seat function in disconnected	Call for service
	Seat function motor defect	Call for service
Wheelchair cannot be charged	Main fuse disconnected	Re-install main fuse
	Main fuse has triggered	Replace main fuse Check first!!! See page 105
	Connection between charger and joystick module not good	Check connection Call for service

Note that this guide cannot describe all the problems and events which may occur and you should always contact your local authorized supplier or Karma in case of doubt.

23.1 Diagnostics R-Net LCD

When an error or a fault occurs in the wheelchair's electronics, information on it is displayed in the control panel's display. This information can then be used to diagnose where the error/fault occurred and its cause.

Troubleshooting and repairs must always be performed by authorized personnel with good knowledge of the wheelchair's electronics.

Diagnostic screens

When the control system's integrated protection circuits have been triggered so that the control system can no longer operate the wheelchair, a diagnostic screen is displayed in the control panel's display.

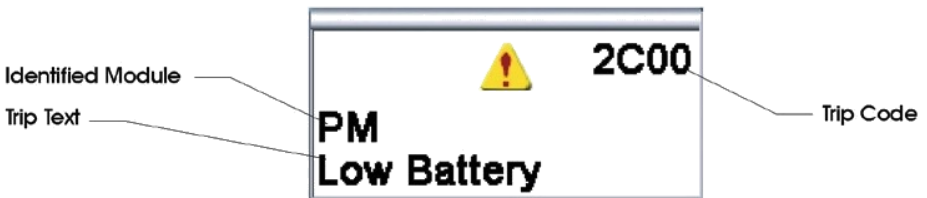

This indicates a system fault, i.e. R-net has detected a problem somewhere in the wheelchair's electrical system.

NOTE

If the fault is in a module that is not currently being used, it may still be possible to drive the wheelchair, but the diagnostic screen is displayed occasionally.

Switch off the wheelchair and leave it off for a few minutes. Then restart the wheelchair. If the fault persists, you must switch off the wheelchair and contact your service contacts. Write down the information displayed in plain text in the control panel's display and pass it on to your local authorized supplier's service contact.

WARNING

Diagnostics should only be performed by authorized persons with sound knowledge of the wheelchair's electronic control system. Incorrect or poorly performed repair works may make it dangerous to use the wheelchair. Karma accepts no liability for any personal injury or damage to the wheelchair and its surroundings that occurs because of incorrect or poorly performed repair work.

24 Technical specifications

length [L]:

1018 mm (without legrests)

width [W]:

625 mm

height [H]:

1120 mm (top backrest frame)

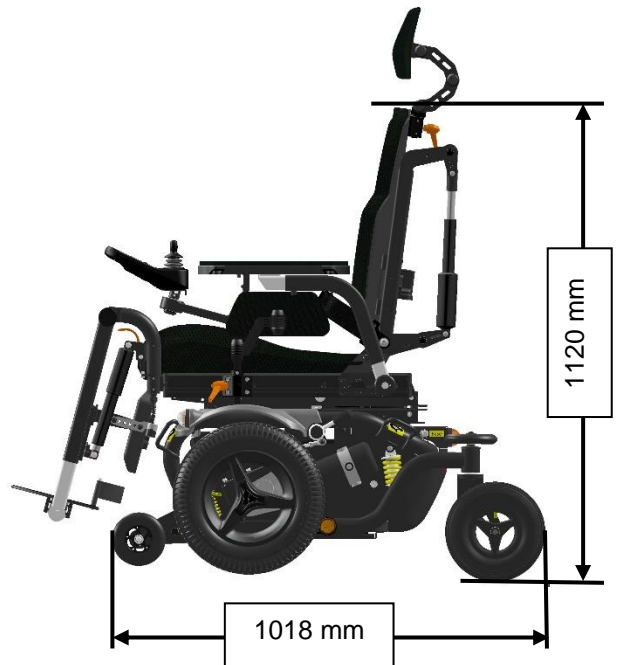

DATA

General

product name	Leon F Versus	
wheelchair class	Class B	
expected service life	> 7 years	

Sizes

length, mm	min.	max.
width, mm	1017	1138
height, mm	625	
weight, kg		1120
	140	193 incl. batt.

Smallest size for transportation

length	1017	1138
width	625	
height		1120
mass of the heaviest part	134	

Wheels

size front	280/250 - 4	
size rear	3.00 - 8	
tire pressure	front	29 PSI, 2 Bar, 200 Kpa
	middle	35 PSI, 2,4 Bar, 240 Kpa

Performance

speed, km/h	min.	max.
drive range, km	6	10
	(depending on size of batteries)	40
minimum turning area (minimum) mm	1250	
minimum turning radius, mm	780 including legrests	
obstacle climb, mm	70	
static stability	downhill	6°
	uphill	6°
	sideways	6°
dynamic stability	uphill	6°
	downhill	6°
	sideways	6°
breaking distance from max. speed, in mm	2100	2100

Seat

effective seat depth, mm	420	600
effective seat width, mm	450	600
seat angle, in degrees	0	45
seat surface height (seat pan to ground)	460	760
maximum user weight, kg		136
backrest angle, in degrees	85	160
backrest height, mm	455	455
footrest to seat distance, mm	390	600
legrest to seat angle, in degrees	108	168
armrest height	180	300
front location of armrest structure	open structure	

Electronics

voltage	PG drives Technology	
power	24 volt	
joystick module	PM90 / PM120	
	R-net CJSM	

Batteries

type	rechargeable, maintenance free	Gel	MPA 50-12, 50A
			MPA 80-12, 80A
charging time	(depending on size of batteries)		6-8 hours

Fuse

main fuse	70A
-----------	-----

The wheelchair conforms to the following standards:

- a) Requirements and test methods for static, impact and fatigue strengths (ISO 7176-8)
- b) Power and control systems for electric wheelchairs – requirements / test methods (ISO 7176-14)
- c) Climatic test accordance with ISO 7176-9
- d) Requirements for resistance to ignition in accordance with ISO 7176-16
- e) crash test according to ISO 7176-19:2008

25 Accessories

Accessories for Karma power wheelchairs are subject to continuous development. Every day we design new accessories to improve the flexibility of our products.

Contact your local authorized Karma supplier for more information on the accessories which are available for your wheelchair.

Should you have a good suggestion for a new accessory, do not hesitate to contact us. Your idea might be the next new accessory!

Worldwide:

Karma Medical
NO.2363, Sec. 2
University Road
Min-Hsiung Shiang
Chia-Yi 621, Taiwan
www.karmamedical.com
globalsales@karma.com.tw

European representative :

Karma Mobility Spain S.L.
C/ Periodista Francisco Carantoña Dubert nº23 bajo
33209 Gijón (Asturias)
Spain

phone: +35 984 39 09 07
mail: karma@karmamobility.es
web: www.karmamobility.es

NOTES:

We have a big dream

Whether it's a customized wheelchair, standing chair, general purpose chair, or another mobility aid device, each of our products is carefully designed with our customers' voices, needs, and desires in mind.

When it comes to user experiences, we strive to be more "caring," "empathetic," and "approachable."

Through our dedication and our mindfulness, we look forward to bringing more confidence, joy, and love for life to those with physical abilities around the world.

we look forward to bringing more confidence, joy, and love for life to those with physical abilities around the world.

Karma Medical is continuously improving their products and accessories. Changes might take place without further notice.

Release 02-2020-UK

karma

A Better Wheelchair, A Better Fit



KARMA MOBILITY S.L European Support Center.
www.karmamobility.es
+34 984 390 907
karma@karmamobility.es

KARMA MEDICAL PRODUCTS CO., LTD.
www.KarmaMedical.com
+886 5 206 6688
globalsales@karma.com.tw