

# PARAVAN®

PARAVAN WHEELCHAIR SERIES

## User manual PR 40



 EN V1.4

Valid for the following model  
Publisher and Copyright:  
Date of issue:  
Document number:

Paravan PR 40  
PARAVAN GmbH  
01/09/2020  
PR40\_V1.4 EN

Dear customer,

We would like to thank you for choosing our PARAVAN PR 40 standing wheelchair.

These operating instructions contain all the important information and instructions regarding your new PR 40. We ask that you carefully read the following pages to ensure that your PR 40 will continue to work without problems for many years to come. Keep these operating instructions "to hand" for future reference. Our operating instructions contain answers to questions that relate to the equipment, operation and care of the PR 40. However, if you still have questions or comments regarding the PR 40, please do not hesitate to contact us.

Your PARAVAN Team

# Contents

## General

<b>1.</b>	<b>Legal notice .....</b>	<b>15</b>
1.1	Your manufacturer .....	15
1.1.1	Copyright .....	16
1.1.2	Technical status of documentation.....	16
<b>2.</b>	<b>Regarding these operating instructions .....</b>	<b>17</b>
2.1	Exclusion of liability .....	18
2.1.1	Guarantee .....	19
2.1.2	Technical modifications .....	20
2.2	Target group.....	22
2.3	Explanation of symbols.....	23
2.3.1	Structure of safety notes.....	24
<b>3.</b>	<b>Safety notes .....</b>	<b>25</b>
3.1	Generally applicable safety notes.....	25
3.1.1	Operation instructions.....	25
3.1.2	Information regarding use.....	29
3.1.3	Information regarding transport .....	30
<b>4.</b>	<b>Performance description .....</b>	<b>31</b>
4.1	Manufacturing standard.....	31
4.2	Correct use.....	32
4.2.1	Usability of the PR 40 .....	33
4.2.2	Clearance declaration for non-dangerous goods (storage battery) .....	34
4.3	Approvals, certifications.....	35
4.3.1	EU approval as a driver seat.....	35
4.3.2	German regulations on assistive technology (Hilfsmittelverordnung, H MV no.) .....	36
4.3.3	Definition of auxiliary equipment (incomplete excerpt) .....	36

4.3.4	Indication.....	37
4.3.5	Contraindications.....	37

## Information

<b>5.</b>	<b>Product-specific data .....</b>	<b>38</b>
5.1	Trademark and type designation (type plate) .....	38
5.2	Location of the type designation (type plate) .....	39
5.3	Important information about your PR 40 .....	40
5.3.1	The type plate of your PR 40 .....	40
5.4	Accessories.....	41
5.4.1	Supplied accessories.....	41
5.4.2	Deliverable accessories.....	41
<b>6.</b>	<b>Description/function of the PR 40.....</b>	<b>42</b>
6.1	The seat.....	42
6.2	Joystick control.....	43
6.3	Special control system .....	43
6.4	Tilt function (seat angle) .....	44
6.5	Road-safe in accordance with The Road Traffic Licensing Act (StVZO).....	45
6.5.1	§ 24 Special means of transportation.....	45
<b>7.</b>	<b>Overview of the PR 40 .....</b>	<b>46</b>
7.1	Parts and their locations .....	46
7.2	Parts and their installation position, chassis.....	47

## Prepare

<b>8.</b>	<b>Handover of the PR 40.....</b>	<b>49</b>
8.1	Receiving your new PR 40 .....	49

8.2	How the PR 40 is supplied to you .....	49
<b>9.</b>	<b>Settings on the PR 40, electronic.....</b>	<b>50</b>
<b>10.</b>	<b>Settings on the PR 40, mechanical .....</b>	<b>51</b>
10.1	Receiving your new PR 40 .....	51
10.2	The armrest pad.....	52
10.2.1	Set the angle of the armrest pad. ....	52
10.2.2	Set the horizontal position of the armrest pad .....	53
10.3	Armrest.....	54
10.4	Set the height of the armrest .....	55
10.5	Angle of the armrest .....	56
10.6	Set the projection of the armrest.....	57
10.7	Setting the mobility of the control panel .....	58
10.8	Footrest unit .....	59
10.8.1	Setting the lower leg length.....	59
10.8.2	Setting the tibial angle.....	60

## Operate

<b>11.</b>	<b>Driving with the PR 40 .....</b>	<b>61</b>
11.1	Insurance, liability insurance.....	61
11.2	Function check before the trip .....	62
11.3	Controlling the PR 40, directions of travel.....	63
11.4	Navigating bends, turning corners.....	64
11.5	Braking with the PR 40 .....	65
11.5.1	PR 40 braking system.....	65
11.6	PR 40 braking characteristics .....	66
11.7	Travelling on hills, up and downhill travel.....	67
11.8	The drive programs / movement levels.....	68

11.9	Manual driving, push mode.....	69
11.9.1	Operation of the brake lock release lever (emergency release) .....	69
11.10	Information regarding roads, types of ground .....	70
11.10.1	Fording ability, driving through water .....	70
11.10.2	Climbing / traversing ability .....	71
11.10.3	Load bearing capacity .....	71
11.10.4	Rough ground or terrain.....	71
11.10.5	Slippery ground, traction .....	71
<b>12.</b>	<b>Parking and storing the PR 40 .....</b>	<b>72</b>
<b>13.</b>	<b>Loading and transporting the power wheelchair.....</b>	<b>73</b>
13.1	Rules for loading wheelchairs.....	73
13.2	Securing and fastening the power wheelchair.....	74
13.3	Fasten the seatbelt in a moving vehicle .....	75
13.4	Securing the wheelchair with a 4 point strap restraint.....	76
13.5	Occupant restraint instruction .....	77
13.6	Dahl Docking Systems Assembly .....	79
13.6.1	Content of Dahl docking stations .....	81
13.6.2	Attaching the Dahl locking plate to the wheelchair .....	83
13.6.3	Attaching the Dahl locking plate to the wheelchair .....	85
13.6.4	Description of the Dahl Docking system functions .....	89
13.6.5	Securing the wheelchair in the docking station.....	90
13.6.6	Release from the docking station.....	92
13.6.7	Manual release in case of electric failure .....	93
<b>14.</b>	<b>Controls .....</b>	<b>94</b>
14.1	Control panel R-NET CJSM2 .....	94
14.1.1	Overview of the control elements.....	94
14.1.2	Status display.....	95
14.1.3	Start, switch off.....	96

14.1.5	Switch direction indicator on and off .....	97
14.1.4	Switch light on and off.....	97
14.1.6	Switch hazard lights on and off .....	98
14.1.7	Driving functions overview .....	99
14.1.8	Select drive program, drive.....	100
14.1.9	Electrical seat adjustment.....	101
14.1.10	Set time/date .....	102
14.1.11	Show/hide clock, configure 12h/24h display.....	103
14.1.13	Adjust display brightness .....	104
14.1.12	Adjust display brightness, automatic (recommended) .....	104
14.1.14	Block the controls (with the wheelchair switched on) .....	105
14.1.15	Release the controls (with the wheelchair switched off) .....	105
14.2	Control panel R-NET CJSM-L .....	106
14.2.1	Overview of the control elements .....	106
14.2.2	Status display.....	107
14.2.3	Start and switch off .....	108
14.2.4	Switch light on and off.....	109
14.2.5	Switch direction indicator on and off .....	109
14.2.6	Switch hazard lights on and off .....	110
14.2.7	Driving functions overview .....	111
14.2.8	Select drive program, drive.....	112
14.2.9	Electrical seat adjustment.....	113
14.2.10	Set time/date .....	114
14.2.11	Show/hide clock, configure 12h/24h display.....	115
14.2.12	Adjust the display background and brightness .....	116
14.2.13	Adjust display brightness .....	116
14.2.14	Block the controls (with the wheelchair switched on) .....	117
14.2.15	Release the controls (with the wheelchair switched off) .....	117



## Help

<b>15.</b>	<b>Moving out of the PR 40 seat.....</b>	<b>118</b>
15.1	Procedure when moving sideways out of the seat.....	119
<b>16.</b>	<b>Maintenance and servicing.....</b>	<b>120</b>
16.1	Service partner.....	120
16.2	Cleaning and care.....	121
<b>17.</b>	<b>Disposal and environmental protection.....</b>	<b>122</b>
17.1	Packaging material.....	123
17.2	Recommissioning.....	124
17.3	Information regarding transfer of the product.....	125
<b>18.</b>	<b>Troubleshooting.....</b>	<b>126</b>
18.1	Status indicator on the control panel.....	126

## Technology

<b>19.</b>	<b>Electrical system.....</b>	<b>128</b>
19.1	Automatic fuses.....	128
19.2	Main fuse.....	129
19.2.1	Resetting a triggered main fuse.....	129
19.3	Overload protection.....	130
19.3.1	Reset the triggered overload protection:.....	130
19.4	Connection option for auxiliary units.....	131
19.5	The lighting installation.....	132
19.6	Maintenance-free storage batteries.....	133
19.7	Information regarding storage batteries.....	134
19.8	Charging the PR 40.....	135

19.8.1	Procedure for charging the PR 40.....	136
19.8.2	The charger .....	137
19.8.3	Installing the charger, installation location .....	137
<b>20.</b>	<b>Technical equipment .....</b>	<b>138</b>
20.1	Technical data and measurements .....	138
20.2	Spare parts .....	143
<b>21.</b>	<b>Electromagnetic compatibility (EMC).....</b>	<b>145</b>
21.1	Information regarding electromagnetic compatibility.....	145
21.2	Compliance level.....	146
<b>22.</b>	<b>Annexes and technical documentation .....</b>	<b>149</b>
22.1	Handling of sealed storage batteries .....	149
22.2	Customer service booklet .....	150
22.3	EC declaration of conformity .....	151
22.4	Log of instructions provided upon delivery.....	152

Fig. 1:	QR code .....	15
Fig. 2:	Direction of travel.....	17
Fig. 3:	Safety instruction.....	24
Fig. 4:	TÜV Logo.....	35
Fig. 5:	Type plate .....	38
Fig. 6:	Location of type plate.....	39
Fig. 7:	DAHL docking station.....	41
Fig. 8:	Illumination at the front .....	45
Fig. 9:	Illumination at the rear .....	45
Fig. 10:	Wheelchair overview.....	46
Fig. 11:	Parts, chassis rear .....	47
Fig. 12:	Parts, chassis front.....	48
Fig. 13:	Angle of armrest pad .....	52
Fig. 14:	Position of the armrest pad .....	53
Fig. 15:	Position check of the armrest.....	54
Fig. 16:	Height of armrest.....	55
Fig. 17:	Armrest angle.....	56
Fig. 18:	Armrest projection .....	57
Fig. 19:	Swivel mechanism.....	58
Fig. 20:	Lower leg angle.....	59
Fig. 21:	Tibial angle.....	60
Fig. 22:	Brake lock release lever (emergency release) .....	62
Fig. 23:	Joystick .....	63
Fig. 24:	Brake lock release lever (emergency release) .....	69
Fig. 25:	Attachment point at the front.....	74
Fig. 26:	Attachment point at the rear .....	74
Fig. 27:	Illustration of improper belt-restraint fit .....	75
Fig. 28:	Illustration of proper belt-restraint fit.....	75
Fig. 29:	Rear securement points .....	76

Fig. 30:	Front securement points .....	76
Fig. 31:	Positioning the occupant restraint with 4 point strap system .....	77
Fig. 32:	Positioning the occupant restraint for use with dahl docking system only .....	78
Fig. 33:	Dahl docking system .....	79
Fig. 34:	Content of Dahl Docking Station MK II standard set # 501750.....	81
Fig. 35:	Content of Dahl VarioDock™ standard set # 503600 .....	82
Fig. 36:	Paravan kit for Dahl docking station.....	83
Fig. 37:	Torx TX 45 .....	83
Fig. 38:	Knurled screws Paravan .....	84
Fig. 39:	Rear and side covers Paravan.....	84
Fig. 40:	Main cable battery .....	85
Fig. 41:	Removing the batteries .....	85
Fig. 42:	Position of the Dahl system .....	86
Fig. 43:	Fastening of the Dahl system .....	86
Fig. 44:	System functions Dahl .....	89
Fig. 45:	Manual release step 1 .....	93
Fig. 46:	Manual release step 2 .....	93
Fig. 47:	Control panel R-NET CJSM2 .....	94
Fig. 48:	Function keys .....	95
Fig. 49:	Status display.....	95
Fig. 50:	Speed control (tortoise) active .....	96
Fig. 51:	„On / off“ key .....	96
Fig. 52:	Light on and off .....	97
Fig. 53:	Turn signal right / left .....	97
Fig. 54:	Light symbol (colour).....	97
Fig. 55:	Hazard lights on / off .....	98
Fig. 56:	Symbols (colour).....	98
Fig. 57:	Driving functions.....	99
Fig. 58:	Charging status indicator (driving function blocked).....	99

Fig. 59:	Select drive program.....	100
Fig. 60:	Joystick travelling direction .....	100
Fig. 61:	Example: Display of seat functions .....	101
Fig. 62:	"Set time" function menu.....	102
Fig. 63:	Setting the time and date .....	102
Fig. 64:	Set clock to visible/invisible.....	103
Fig. 65:	Setting the display brightness.....	104
Fig. 66:	Autom. display brightness .....	104
Fig. 67:	Blocking the controls .....	105
Fig. 68:	Lock symbol .....	105
Fig. 69:	Control panel R-NET CJSM-L .....	106
Fig. 70:	Function keys .....	107
Fig. 71:	Status display.....	107
Fig. 72:	"On / off" key .....	108
Fig. 73:	Speed control (tortoise) active .....	108
Fig. 74:	Light on and off .....	109
Fig. 75:	Turn signal right / left .....	109
Fig. 76:	Light symbol (colour).....	109
Fig. 77:	Hazard lights on / off .....	110
Fig. 78:	Symbols (colour).....	110
Fig. 79:	Driving functions.....	111
Fig. 80:	Driving function blocked.....	111
Fig. 81:	Select drive program.....	112
Fig. 82:	Joystick travelling direction .....	112
Fig. 83:	Display of seat functions.....	113
Fig. 84:	"Set time" function menu.....	114
Fig. 85:	Setting the time and date .....	114
Fig. 86:	Set clock to visible/invisible.....	115
Fig. 87:	Setting the display brightness .....	116

Fig. 88:	Setting the display background .....	116
Fig. 89:	Blocking the controls .....	117
Fig. 90:	Controls blocked – block symbol .....	117
Fig. 91:	Move from the seat, footrests.....	119
Fig. 92:	Move from the seat, armrest.....	119
Fig. 93:	Recycling .....	123
Fig. 94:	Main fuse, active.....	129
Fig. 95:	Main fuse.....	129
Fig. 96:	Illumination at the front .....	132
Fig. 97:	Illumination at the rear .....	132
Fig. 98:	Plug in the charging cable.....	136
Fig. 99:	Set up charger .....	137
Fig. 100:	EC declaration of conformity .....	151

# 1. Legal notice

## 1.1 Your manufacturer

PARAVAN GmbH  
Registered office / headquarters / production



Fig. 1: QR code



Paravanstraße 5-10, D-72539 Pfronstetten-Aichelau

- > Tel.: +49 73 88 / 99 95-91
- > Fax: +49 73 88 / 99 95-999
- > Email: [info@paravan.de](mailto:info@paravan.de)
- > Internet: [www.paravan.com](http://www.paravan.com)
- > Managing Director: Mr. Roland Arnold



Many mobile telephones and PDAs have built-in cameras and software which allows the interpretation of QR codes, and with these you can directly transfer our contact information into the address book of your mobile phone or PDA.

## 1.1.1 Copyright

This documentation and all of its parts are protected by copyright. All rights arising from this copyright, especially those relating to the translation, reprint, presentation, use of illustrations and tables, radio broadcasting, microfilming or reproduction of information in other ways, and the storage of such information in data processing systems, also with regard to the use of specific extracts, remain reserved. The reproduction of this work or a part of this work, even in individual cases, is only permitted within the limits of the statutory provisions of the current version of the Copyright Act (Urheberrechtsgesetz) of the Federal Republic of Germany of 9 September 1965. Such reproduction is generally subject to a fee. Contraventions are subject to the penal provisions of the Copyright Act.

➤ Copyright © PARAVAN GmbH 2017. All rights reserved!

## 1.1.2 Technical status of documentation

All details on technical data / specifications, illustrations and information in these operating instructions correspond to the information available at the editorial deadline in June 2019.

The operating instructions for the PR 40 have been produced in the German language and can be translated into other languages; however in the case of any differences, the German version is legally binding.



## 2. Regarding these operating instructions



Fig. 2: Direction of travel

These operating instructions do not constitute a maintenance and repair manual and therefore are not suitable to use for the private carrying out of maintenance and repair work, or to provide instruction on this. You will receive information on the design and the operation of the product throughout its entire life cycle – from transport (delivery) to decommissioning (shutdown) of the PR 40. The most important product features are listed and described below. All the specified product features can be combined with one another in different variants and functions, and can potentially differ from the series-production standard.



### NOTE

These operating instructions are an essential part of the power wheelchair product and must always be kept near the PR 40 so that you can quickly access all important information.



All information on sides and directions in this documentation is always specified from the point of view of the operator and in the direction of travel!

## 2.1 ***Exclusion of liability***

The operation of the PR 40 without faults or malfunctions can only be guaranteed if the information gained from these operating instructions is applied. PARAVAN GmbH assumes no liability or guarantee regarding damage or malfunctions that occur during operation due to the non-observance of these operating instructions or due to modifications made to the PR 40.

In order to guarantee the fault-free operation of your PR 40, please observe the maintenance instructions and maintenance intervals.



See chapter “17 Maintenance and servicing”

## 2.1.1 Guarantee

Guarantee services are based entirely on the respective PARAVAN guarantee provisions.

Excluded from guarantee claims is damage which has occurred due to:

- > Wear
- > Improper operation or use, e.g. overloading
- > Incorrect/infrequent maintenance
- > Incorrect/infrequent care



See your personal "guarantee card".

## 2.1.2 Technical modifications

All modifications to safety equipment, and technical modifications to the PR 40 in general, even if only minor, are strictly prohibited! All modifications must be authorised or carried out by PARAVAN GmbH.

PARAVAN GmbH reserves the right to undertake technical modifications and improvements to the product in the interest of our customers and progressive development.



### **NOTE**

Claims relating to the guarantee and warranty shall expire in the event that any modification is made to the PR 40 that was not authorised by PARAVAN GmbH. Furthermore, dangerous malfunctions cannot be ruled out!

 <b>WARNING</b>	
>	<b>Danger of injury</b> for persons operating a PR 40 which does not correspond to the original or delivered condition.
>	<b>Material damage</b> to the PR 40 through the use of unapproved parts or incorrectly installed parts.
>	Do not make any technical modifications to the power wheelchair.
>	Only operate the PR 40 in its original or delivered condition.
>	Use only original and approved replacement parts.
>	Check the operating condition of the PR 40 before each trip.

## 2.2 Target group

The operator must acquire or gain a level of knowledge relating to the following points before operating the PR 40:

- > Knowledge of the content of the operating instructions in order to safely operate and also be able to move the PR 40.
- > Knowledge of the safety and operating provisions listed herein in order to recognise potential dangers or dangerous situations and avert these for the user and his/her surroundings.



### NOTE:

In order to ensure their own personal safety, only trained or instructed persons may operate a power wheelchair. As a user, please ensure you receive sufficient training when the product is supplied. If necessary, please contact us.



See section "24.4 Log of instructions upon supply"

## 2.3 Explanation of symbols

When reading the operating instructions you will encounter the following symbols and warning symbols.



### The "Caution Danger!" logo

highlights hazards. The protective measures specified in the respective text must be followed in all cases. This symbol is always used in combination with the respective signal word, which indicates the level of danger:

- > **Danger!** - Immediate danger to life and limb (irreversible).
- > **Warning** - potential danger to life and limb (irreversible).
- > **Caution** - potential danger to life and limb (reversible).
- > **Caution** - potential damage to the vehicle.



Additional information for the user – e.g. in order to simplify the operation of the PR 40 and/or avoid damage to the PR 40.



This symbol refers the user to further sections or further documentation – e.g. also to annexes of these operating instructions.

## 2.3.1 Structure of safety notes

You can obtain the following information from the safety notes:

- Warning or danger symbol ①.
- Type and source of the danger ②.
- Signal word ③.
- Consequences of hazard occurring ④.
- Protective measures ⑤.

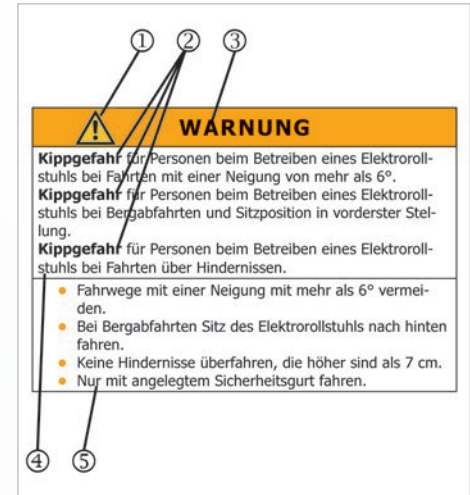

Fig. 3: Safety instruction



### 3. Safety notes

#### 3.1 Generally applicable safety notes

##### 3.1.1 Operation instructions

For your protection and for the protection of people in your vicinity and of the environment, the following safety instructions must be observed and followed at all times.

 <b>DANGER!</b>	
>	<b>Danger of crushing</b> from touching moving parts, e.g.
>	from the rotational movement of the drive wheels or the
>	lifting motion of the functional unit.
>	<b>Danger of falling</b> due to unintentional movement of the PR 40 due to an inactive braking mechanism.
>	<b>Danger of falling</b> from abrupt braking of the PR 40 if the vehicle is without power.
>	Do not touch moving parts.
>	Assistants must not touch parts in the danger zones while operating the power wheelchair.
>	Brake lock release lever must be in the "LOCK" position.
>	Never switch the power of the PR 40 off or shut it down while travelling.



## WARNING

**Danger of tipping** for persons operating a PR 40 when travelling at an incline of more than 10°.

**Danger of tipping** for persons operating a PR 40 when travelling downhill and if the seat is in the foremost position.

**Danger of tipping** for persons operating a PR 40 when travelling over obstacles.

- > Avoid routes with inclines greater than 10°.
- > Tilt the seat of the PR 40 back when travelling downhill.
- > Do not cross any obstacles which are higher than 60-70 mm.
- > Only drive with your seatbelt fastened
- > Do not drive in a horizontal (lying) position.
- > Only drive in the lowest seat position.
- > Only use the lifting, recline and tilting function on level surfaces.



## WARNING

**Danger of injury** for persons operating a PR 40 which does not correspond to the original or delivered condition.

**Material damage** to the PR 40 through the use of unapproved parts or incorrectly installed parts.

- > Do not make any technical modifications to the power wheelchair.
- > Only operate the PR 40 in its original or delivered condition.
- > Use only original and approved replacement parts.
- > Check the operating condition of the PR 40 before each trip.



## WARNING

**Danger of injury** for persons while travelling with a PR 40 on rough ground.

**Danger of falling and tipping** for persons while operating the PR 40 on surfaces with diminished load bearing capacity.

**Material damage** to the PR 40 from mechanical and physical influences while travelling on rough terrain.

- > Avoid travelling on flat, slippery or greasy surfaces (e.g. ice, snow, wet grass, foliage, etc.).
- > Avoid travelling through water with a depth of 50mm or more.
- > Observe the gross load weight of the vehicle.
- > Observe the load bearing capacity (e.g. in the case of bridges or crosswalks) or condition of the ground.
- > Only drive with your seatbelt fastened.

### 3.1.2 Information regarding use

 <b>CAUTION</b>	
<b>Material damage</b> to the PR 40 from overloading the vehicle.	
<b>Material damage</b> to the PR 40 from the effects of high temperatures above 41°C.	
<b>Material damage</b> to the PR 40 from overcharging of the batteries when travelling downhill.	
<ul style="list-style-type: none"><li>&gt; Only use the PR 40 for its intended purpose.</li><li>&gt; Overloading the PR 40 (e.g. with a second person or other loads) is not permitted.</li><li>&gt; Protect the PR 40 from strong solar radiation and other sources of heat.</li><li>&gt; Switch on the electricity consumers (e.g. the lights) when travelling downhill.</li></ul>	

### 3.1.3 Information regarding transport



## CAUTION

**Material damage** to the PR 40 if it slips from a ramp or a lift during loading.

**Material damage** to the PR 40 due to improper securing or transport in the transport vehicle.

- > Secure ramp against slipping.
- > The ramp / vehicle used to transport the PR 40 must be level and stand on solid ground.
- > Ramp or lift must be clean and dry.
- > Ramp must be wider than the PR 40 and easily visible in order to facilitate corrective steering movements.
- > Drive onto ramp and lift without pausing in order to avoid rolling backwards.
- > Secure the PR 40 in the transport vehicle in accordance with standard legal provisions.
- > Only use suitable and authorised slings.
- > Shut down the PR 40 during transport.

## 4. **Performance description**

### 4.1 **Manufacturing standard**

The PARAVAN PR 40 is a multifunctional power wheelchair that is ideal for indoor and outdoor use due to its compactness and manoeuvrability.

The PR 40 is designed and tested to ensure the highest possible degree of safety for the operator and his/her surroundings. Our products are checked for faults after their manufacture. If a fault or malfunction nevertheless arises with your PR 40, we ask that you contact your dealer or PARAVAN GmbH directly so that the issue can be dealt with.

PARAVAN power wheelchairs are manufactured and tested in accordance with:

- DIN EN 12184 Electrically powered wheelchairs, scooters and their chargers.

and are classified as Category B in this standard.

## 4.2 Correct use

The PARAVAN PR 40 is designed to transport a person indoors and outdoors. The control panel, including the joystick and optional controls for special operation, serves as the interface in terms of user operation and the liability of the manufacturer of the PR 40.

**NOTE**

The PR 40 is only intended for the uses listed in the section “Usability of the vehicle”.



See section “3 Safety notes”



See section “4.2.1 Usability of the PR 40”



## 4.2.1 Usability of the PR 40

### - unproblematic

- > Transport of a person with a maximum body weight of 140kg.
- > Use as driver's or co-driver's seat, depending on the equipment variant.
- > Use within the German road traffic regulations ("StVO"), assuming complete and intact lighting.



See section "12 Driving with the PR 40"

### - problematic or prohibited

- > Use as a means of tractive transport of loads or of several people.
- > Use of the PR 40 in extreme climatic conditions (heat/cold/moisture).



See section "2.1 Exclusion of liability"



See section "3 Safety notes"

## 4.2.2 Clearance declaration for non-dangerous goods (storage battery)

PARAVAN GmbH uses storage batteries which are classified as "non-dangerous goods", as long as these storage batteries are not mechanically damaged in any way.

The maintenance-free non-woven lattice storage batteries and the maintenance-free lead gel storage batteries are leak-proof, and in accordance with

- > IATA, regulation A 67
- > ADR, regulation 238 B
- > IMDG, regulation 238.2 and

UN 2800 Special Provisions are considered **not dangerous goods** and suitable for transport.



See "Clearance certificate for non-dangerous goods"



You will receive the respective appropriate clearance certificate for your storage batteries when you receive your PR 40.

### 4.3 Approvals, certifications

#### 4.3.1 EU approval as a driver seat

The anchoring of the safety belt has been certified and approved in accordance with 76/115/EEC as has the seat in relation to its anchoring in accordance with 74/408/EWG with the Paravan docking system.

 <b>DANGER!</b>
<b>Potential risk of injury or serious injury or death</b>
<p>In conjunction with the Dahl Docking system the wheelchair has been successfully crash-tested according to ISO 7176-19:2008 - Wheeled mobility devices for use as seats in motor vehicles. The test was carried out with vehicle anchored safety belt system only. The integrated 3- or 4-point seat belt should not be used or relied on for occupant restraint in a moving vehicle. Use a vehicle installed and approved 3 point belt instead.</p>



Fig. 4: TÜV Logo

> Technical Reports Nos. 08-00719-CP-GBM and 08-00723-CP-GBM.



See Section "23 Annexes and technical documentation"

### 4.3.2 German regulations on assistive technology (Hilfsmittelverordnung, HMV no.)

The PR 40 standing wheelchairs are approved in accordance with assistive technology guidelines:

- Kassenarztrecht in Nordwürttemberg – Richtlinien und Normen und Verordnungen und Leistungen (Panel doctors law in Northern Württemberg - guidelines and standards and regulations and services), page B 2 - 1 ff

As auxiliary equipment permitted under the German regulations on assistive technology, number:

- HMV no. 18.99.03.2035

### 4.3.3 Definition of auxiliary equipment (incomplete excerpt)

Auxiliary devices are physical medical services i.e. things which succeed in making medical treatment safe by their compensatory, supportive or relieving effect, or which allow physical hindrances to be overcome. They include prostheses, orthopaedic and other auxiliary equipment, visual aids, physical tools or technical products...

#### 4.3.4 Indication

The inability to walk or severely limited ability to walk within the context of the basic need to move in your own home.

The provision of wheelchairs with a standing feature is advisable if regular (several times per day) standing training must be carried out as a therapeutic action, and other standing aids, e.g. underarm crutches, axillary crutches, walking frames, cannot be used.

These wheelchairs are only used if manually operated standing devices cannot be operated due to the wheelchair user's low level of residual strength.

#### 4.3.5 Contraindications

The provision of power wheelchairs is unsuitable for persons with:

- > Severe balance disorders
- > Limited and inadequate vision
- > Severely limited cognitive abilities
- > Loss of both arms, or the inability to sit

## 5. Product-specific data

### 5.1 Trademark and type designation (type plate)



This information can be found on the type plate. It is very important to provide this in any correspondence with PARAVAN GmbH so that you receive relevant professional advice.

- > Model name ①
- > Series number, chassis no. ②
- > Production date ③
- > Max. speed ④
- > HMV number ⑤
- > PR 40 unladen weight ⑥
- > Max. payload (body weight) ⑦

Fig. 5: Type plate



See section “5.3.1 Type plate of your PR 40”

## 5.2 *Location of the type designation (type plate)*

The type designation (type plate) is affixed to the PR 40 in a 1-fold design. The type designation (type plate) has dimensions of approx. 70 mm x 40 mm.

- > The type designation (type plate) is situated on the rear right of the battery box ① of the PR 40.



Fig. 6: *Location of type plate*

## 5.3 **Important information about your PR 40**

Please make sure this information is recorded when you receive the PR 40, or if necessary enter the information yourself, so that you always have it to hand.

- > Day of delivery/supply
- > Supply by (dealer or branch)

### 5.3.1 The type plate of your PR 40

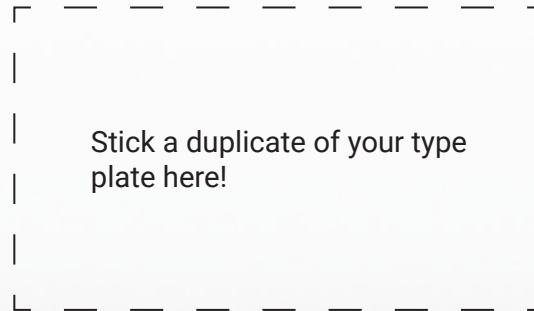



## 5.4 Accessories

### 5.4.1 Supplied accessories

- > Charger with charging cable.
- > Operating instructions.
- > Socket wrench with T-handle, SW 13.
- > Allen key, size 5.



Fig. 7: DAHL docking station

### 5.4.2 Deliverable accessories

- > DAHL docking station for quick and easy fastening of the PR 40 in a vehicle.



Fig. 8: DAHL Vario Dock (height adjustabel)

## 6. **Description/function of the PR 40**

### 6.1 **The seat**

The PR 40 seat is an in-house development from PARAVAN GmbH that is precisely tailored to the needs of customers. The PR 40 features:

- Special shock absorbers in the seat to provide relief to the thigh muscles.
- 6-axles with 12-fold individual adjustment of the armrest in order to be able to set an optimum and fatigue-free position for the arms.
- MeshTex textile cover made from breathable nanofabric to reduce the risk of decubitus.

General

Information

Prepare

Operate

Help

Technology

## 6.2 Joystick control

All the functions of the PR 40 can be selected or accessed via the joystick, the control panel and the integrated control system. Such functions include:

- > steering,
- > braking behaviour,
- > speed, control of the two drive motors,
- > secondary functions, depending on which control system or equipment is used.

## 6.3 Special control system

A multitude of special controls, such as

- > chin control,
- > environmental control,
- > etc.

can be implemented in the PR 40.



If you have requests or suggestions for us regarding this, please do not hesitate to contact us. Thank you.

## 6.4 Tilt function (seat angle)

The PR 40 is equipped with a tilt function. The tilting process can be interrupted and fixed in any direction of movement and at any position.

The seat tilt (angle) can be set as follows at the touch of a button:

> forwards, thus also serving as a standing aid

**or**

> backwards – for relaxing, preventing pressure sores, easing back pain and ensuring better weight distribution.



See section “11 The seat, operation”

## 6.5 Road-safe in accordance with The Road Traffic Licensing Act (StVZO)

The PR 40 is a road-approved vehicle that includes the following features as standard equipment:

- > LED headlights for optimum illumination ①.
- > LED direction indicator ②.
- > LED rear lights for the best possible visibility ③.
- > Identification by yellow reflectors on the side in the middle of the wheel.



Fig. 9: Illumination at the front

### 6.5.1 § 24 Special means of transportation



The Road Traffic Licensing Act (StVZO) makes reference to wheelchairs. In it, it is stated that:

- > (1) Push and gripping wheelchairs, sledges, prams, scooters, children's bikes and similar means of transportation are not vehicles as defined in this Act.
- > (2) Wheelchairs or other wheelchairs as defined in section 1 may be driven in places where there is pedestrian traffic, however only at walking speed.



Fig. 10: Illumination at the rear

## 7. Overview of the PR 40

### 7.1 Parts and their locations

General

Information

Prepare

Operate

Help

Technology

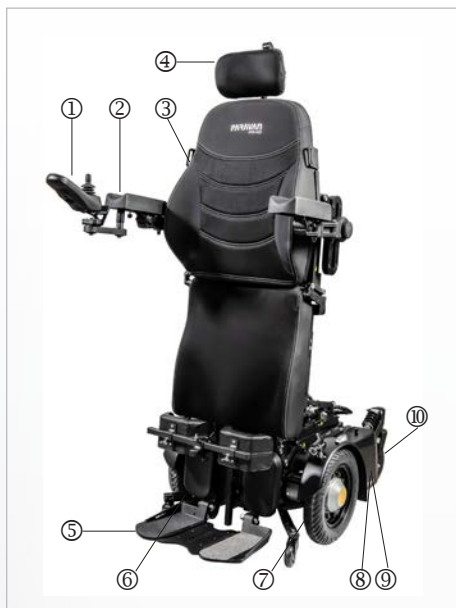

Fig. 11: Wheelchair overview

The following terms for parts or individual parts are used in the operating instructions. Their location on the PR 40 is shown in the photo.

- > Control panel with joystick ①
- > Armrest axle adjustable ②
- > Back rest (electric) ③
- > Headrest ④
- > Footplate/footrests ⑤
- > Brake lock release lever, emergency release ⑥
- > Drive wheel, standard version puncture-resistant ⑦
- > Battery box ⑧
- > Casing ⑨
- > Rear wheel, standard version puncture-resistant ⑩

## 7.2 Parts and their installation position, chassis

The following terms for parts or individual parts are used in the operating instructions. The installation position on the chassis of the PR 40 is shown in the photo.

- Seat plate ①
- Seat guides ②
- Rear wheel ③
- Rigging eye, rear ④
- Actuator module ⑤
- Battery box ⑥
- Storage battery ⑦



Fig. 12: Parts, chassis rear



- Drive wheel ①
- Rigging eye ②
- Control units ③
- Brake lock release lever, emergency release ④
- Drive motor ⑤

Fig. 13: Parts, chassis front



## 8. **Handover of the PR 40**

### 8.1 **Receiving your new PR 40**

Check your PR 40 for completeness and compare the items received in the delivery with your order documents. If anything is unclear, contact PARAVAN GmbH immediately!

Check (visually inspect) that the PR 40 is in proper condition. Report damage which can be attributed to delivery or transport immediately and in writing to your

> dealer, forwarding agent or medical supply store

**and**

> PARAVAN GmbH.

### 8.2 **How the PR 40 is supplied to you**

The PR 40 is supplied to you in the following ready to drive and ready to operate condition:

- > Fully assembled and with equipment corresponding to your specifications upon ordering.
- > All attachments and control elements are preset to your body measurements in accordance with the order.
- > Precharged storage batteries.

## 9. Settings on the PR 40, electronic

General

Information

Prepare

Operate

Help

Technology

The setting and configuration of the PARAVAN control unit is very complex and, for your own safety, can only be undertaken by your service technician.

All parameters of the PARAVAN control unit can be subsequently set to your requirements and desires. These include:

- > All driving features such as e.g. moving off and braking.
- > Steering behaviour.



If an adjustment of the control parameters is necessary or desired, please contact your dealer or PARAVAN GmbH.

## 10. Settings on the PR 40, mechanical

### 10.1 Receiving your new PR 40

All mechanical parts or equipment and control elements are set to your body dimensions. If adjustment is still needed however, this can be undertaken at any time. Your PARAVAN PR 40 is designed in such a way that it can be adjusted to your body dimensions in all respects.



For your own safety, only allow your service technician to carry out all mechanical settings or modifications to the equipment. The customer should not change these settings himself!



See section "24.4 Log of instructions upon supply"

## 10.2 *The armrest pad*



The angle of the armrest pad can be tilted. It can also be adjusted horizontally forwards or backwards, allowing it to be adapted for any purpose and to every body size.

### 10.2.1 Set the angle of the armrest pad.

These instructions apply to both the right and left sides.

- Loosen hexagonal cap nut ①.
- Swing the armrest pad ② into the desired position.
- Tighten hexagonal cap nut ① , approx. 8 Nm.



Fig. 13: Angle of armrest pad

## 10.2.2 Set the horizontal position of the armrest pad



Fig. 14: Position of the armrest pad

These instructions apply to both the right and left sides.

Proceed as follows to check and set the position of the armrest pad:

- > Loosen the ① wing bolt.
- > Push the armrest pad ② forwards or backwards to the desired position.
- > Tighten the wing bolt ① hand-tight.

## 10.3 Armrest

The armrest is multi-horizontal in all directions (projection) and can be vertically adjusted or adjusted at an angle, and thus can be adapted to every body measurement.



Changing the position of the armrest potentially involves using another setting!

Proceed as follows to check and set the position of the armrest:

- Height ① of the armrest.
- Angle ② of the armrest.
- Projection ③ of the armrest.
- If required, correction of the armrest pad.

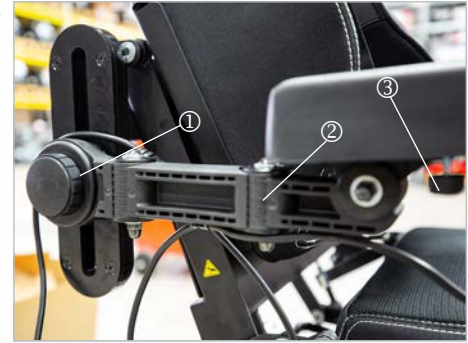

Fig. 15: Position check of the armrest

## 10.4 Set the height of the armrest



Fig. 16: Height of armrest

These instructions apply to both the right and left sides.

Turning the hand-operated wheel to the left releases the armrest, thereby enabling its height to be adjusted.

When the desired height is reached, turn the hand-operated wheel to the right and pull it tight.

> Armrest is locked or fixed.

## 10.5 *Angle of the armrest*



The armrest is pivoted on the attachment point. This allows the complete armrest to be swung upwards for comfortable sitting and standing or moving from the wheelchair's seat.

Fig. 17: Armrest angle



## 10.6 Set the projection of the armrest

This work instruction applies to the right and left sides; it is possible that the rotational direction of the screw connection is reversed!

Proceed as follows to check and set the projection of the armrest:

- > Loosen hexagonal cap nut ①.
- > Loosen hexagonal cap nut ③.
- > Move the armrest ② into the desired position.
- > Hexagonal cap nut ① and ③ tighten approx. 8 Nm.



Fig. 18: Armrest projection

## 10.7 *Setting the mobility of the control panel*



Fig. 19: Swivel mechanism

The horizontal swivel mechanism of the control panel can be set in relation to the degree of hardness (response behaviour or the mobility of the joints).

## 10.8 Footrest unit

The footrest unit's angle relative to the seat can be adjusted using the electrical angle compensation function. The angle of the footplates can only be altered manually using a set screw.

### 10.8.1 Setting the lower leg length

The lower leg support or lower leg length is set to your body dimensions.

- > Manually adjustable



Fig. 20: Lower leg angle

## 10.8.2 Setting the tibial angle



Fig. 21: Tibial angle

The support of the lower leg or the tibial angle (between upper and lower leg) can be electrically modified via the PARAVAN control unit in the angle adjustment setting, depending on the equipment version.

- > Select menu in the control unit.
- > Select the settings.



See section "15 Control"

## 11. Driving with the PR 40

### 11.1 Insurance, liability insurance

We recommend that you speak with your insurance advisor before starting to use the PR 40 so that its use is included in your insurance – in particular in your liability insurance.



Please note that within the context of applicable legal provisions, a legal requirement may exist to insure the PR 40 during use in road traffic.



#### WARNING

**Danger of injury** for persons operating a PR 40 which does not correspond to the original or delivered condition.

**Material damage** to the PR 40 through the use of unapproved parts or incorrectly installed parts.

- > Do not make any technical modifications to the power wheelchair.
- > Only operate the PR 40 in its original or delivered condition.
- > Use only original and approved replacement parts.
- > Check the operating condition of the PR 40 before each trip.

## 11.2 *Function check before the trip*

Before commencing each trip, the following points must be checked for your own safety:



It might be necessary to draw on the expertise of a second person for the check.

- > Function check of the brakes.



The brake lock release lever ① must be set to "**LOCK**", i.e. point upwards.

- > Charging status of the storage batteries.
- > Function check of the lighting installation.



See section "12.9.1 Operation of the brake lock release lever (emergency release)"



See section "20 Electrical Equipment"

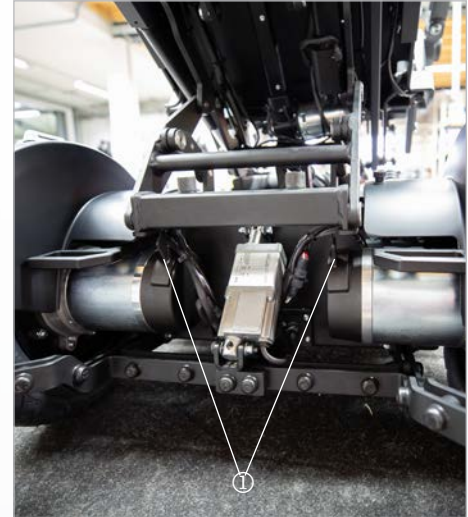

Fig. 22: Brake lock release lever (emergency release)

## 11.3 Controlling the PR 40, directions of travel



The PR 40 is controlled via the joystick on the control panel.

The following basic control options are available if you put the joystick into the positions below:

- > Joystick forwards & The PR 40 travels forwards.
- > Joystick left or right & The PR 40 changes the direction of travel in accordance with the position selected.
- > Joystick backward & The PR 40 travels backwards.
- > Joystick in the neutral position (middle) & The brakes are active, the wheelchair does not travel.



In order to avoid unwanted movement of the PR 40, do not perform any sudden movements (driving commands) on the joystick!



Firstly, practise controlling the wheelchair on safe and accessible terrain.



Fig. 23: Joystick

## 11.4 Navigating bends, turning corners



The PARAVAN PR 40 is equipped with front-wheel drive. This means that the rear swings out during steering motions, i.e. turning corners.

This is how you navigate a bend:

- > Push the joystick into the required travelling position (forwards or backwards).

**And at the same time,**

- > push the joystick into the required travelling direction (left or right).

**Example:**

- > Push the joystick into the position, from the point of view of the operator, of right upwards (2:00 pm position) & The PR 40 curves to the right.



See section "3 Safety notes"



## 11.5 **Braking with the PR 40**

### 11.5.1 PR 40 braking system

Two independently working braking systems (safety systems) are used in the PARAVAN PR 40 in order to guarantee the greatest possible level of safety. The PR 40 has a parking and service brake which complies with the Road Traffic Licensing Regulation (StVZO). The functions of the individual safety systems are as follows:

- > Safety during the trip: By releasing the joystick (the joystick always returns to its neutral position in the middle) in driving mode, the motor brake automatically switches itself on and brakes the PR 40.
- > Safety in the case of a power cut or interruption: If there is an interruption to the power supply, e.g. due to a discharged storage battery, the safety magnet brake locks and the PR 40 comes to a standstill. If this is the case, it can only be mechanically unlocked and manually moved.



See section "12.9.1 Operation of the brake lock release lever (emergency release)"

## 11.6 **PR 40 braking characteristics**

The braking distance, i.e. the distance from initiating the braking process until the PR 40 comes to a standstill, is heavily dependent on factors such as:

- > Ground or condition of the road.
- > Total weight (vehicle and driver) of the PR 40.



When braking from full speed at approx. 6km/h, your PR 40 has a braking distance of approx. 1 metre! During the braking process from high speeds, especially in the case of downhill travel, the power wheelchair can lurch from side to side or swerve. For this reason avoid sharp braking!

## 11.7 Travelling on hills, up and downhill travel

You must observe the following rules for your own safety when travelling up and downhill:

- Put the longitudinal seat adjustment mechanism into the furthest back position in order to avoid slipping.
- Only travel with your seatbelt fastened.
- Avoid sharp braking during downhill travel so that the PR 40 does not lurch from side to side or swerve.
- When travelling up and downhill select a low movement level or speed so that you don't lose control over the PR 40 at any time.
- When travelling up and downhill from an incline of more than 7°, the stability of the PR 40 cannot be guaranteed, or there can be a danger of the PR 40 tipping.
- The power generated during downhill travel is diverted into the battery. If the battery is fully charged upon commencing the trip, the safety system switches to emergency stop in order to avoid damage due to the overloading of the electronics. If this is the case, switch an electricity consumer (light) on in order to run down the battery, and then continue your trip.



The brake lock release lever must be set to "**LOCK**" when travelling up or downhill. The motor brake is only effective when set to "**LOCK**". The result of this would be travelling downhill without braking!



See section "12.9.1 Operation of the brake lock release lever (emergency release)"

## 11.8 The drive programs / movement levels

The PARAVAN PR 40 has five different drive programs, or movement levels. You can select the desired movement level or final speed of the PR 40 on the control panel.

The maximum final speed in the respective movement level is reached by moving the joystick as far as it will go.

The functions of the individual movement levels are as follows:

- > **Movement level 1:** Highest degree of control over the PR 40; 20% of the final speed, driving indoors.
- > **Movement level 2:** 40% of the final speed.
- > **Movement level 3:** 60% of the final speed.
- > **Movement level 4:** 80% of the final speed.
- > **Movement level 5:** Only for practised drivers/operators; max. final speed.



See section "15 Control"

## 11.9 Manual driving, push mode

### 11.9.1 Operation of the brake lock release lever (emergency release)

- > If you want to push the PR 40, you must set both brake lock release levers ① on the left and right drive side to **"UNLOCK"** (downwards).



Do not set to **"UNLOCK"** on a gradient! In this position, the drive motor is unable to brake!

#### Positions of the brake lock release lever ①

##### LOCK

- > Lever position upwards = driving; braking system is active!

##### UNLOCK

- > Lever position downwards = pushing; braking system is deactivated!

**CAUTION:** During push mode the control unit must be switched off!



Fig. 24: Brake lock release lever (emergency release)

## 11.10 Information regarding roads, types of ground

General

Information

Prepare

Operate

Help

Technology



### WARNING

**Danger of tipping** for persons operating a PR 40 when travelling at an incline of more than 10°.

**Danger of tipping** for persons operating a PR 40 when travelling downhill and if the seat is in the foremost position.

**Danger of tipping** for persons operating a PR 40 when travelling over obstacles.

- > Avoid routes with inclines greater than 10°.
- > Move the seat of the PR 40 back when travelling downhill.
- > Do not cross any obstacles that are higher than 60-70mm.
- > Only travel with your seatbelt fastened.

### 11.10.1 Fording ability, driving through water

- > When driving through water, damage to the electronic parts (motors, control units etc.) as well as to the storage batteries due to the ingress of water can occur.

### 11.10.2 Climbing / traversing ability

- > While travelling over obstacles that are higher than approx. 60-70 mm, you could touch the ground and get stuck or tip over with your PR 40 with the battery box.

### 11.10.3 Load bearing capacity

- > Do not travel across grounds on which there is a danger that you could fall and therefore could become stuck or tip over. Keep the total weight of the vehicle in mind.



See section "22.1 Technical data and dimensions"

### 11.10.4 Rough ground or terrain

- > When travelling on rough ground or terrain, there is a danger that you could get stuck or tip over with your PR 40.

### 11.10.5 Slippery ground, traction

- > When travelling over slippery ground (e.g. uncoated ramps, wet grass, snow, ice, etc.) your PR 40 can lose traction. This means that the drive power or the braking power is not transferred.



The PR 40 has a parking and service brake which complies with the Road Traffic Licensing Regulation (StVZO).

## 12. *Parking and storing the PR 40*

In order to avoid damage to the PR 40, you must observe the following rules if you park the PR 40 (e.g. overnight) or do not use it for an extended time period:

- Create a connection to the charging device.
- Choose a dry parking space.
- Do not expose the PR 40 to high or to too low temperatures.
- Cover the PR 40 with a suitable cover.



## 13. Loading and transporting the power wheelchair



The power wheelchair must always be shut down and correctly secured or fastened in the transport vehicle. When loading the power wheelchair, you can use loading aids such as ramps, lifts and hoists with sufficient load-bearing capacity.

### 13.1 Rules for loading wheelchairs

The following rules must be observed for and during loading:

- The maximum support height specified on the ramp must be greater than the height from the ground to the support edge to be cleared (e.g. in the case of a car, the car boot area).
- Check the loading capacity of the ramp(s), of the lift or the hoist.
- Due to safety reasons, the power wheelchair may only be loaded into cars or on split ramps when unoccupied (without baggage or a person).
- Loading may only be carried out by a person who can safely operate and control your power wheelchair.
- A power wheelchair which is unfit to drive may only be loaded by your authorised specialist workshop. This workshop is the only entity aware of the possible danger situations and how to counter them.

## 13.2 Securing and fastening the power wheelchair

The power wheelchair must be connected or tied to the transport vehicle with tightening straps, hooks or loops in order to prevent slipping. The power wheelchair must be fastened in accordance with the guideline

- DIN 75078 (parts 1 and 2) "Vehicles for the transportation of persons with reduced mobility"

The power wheelchair has the following attachment points:

- At the front, two rigging eyes ①
- At the rear, one rigging eye ②



If your vehicle is equipped with a DAHL docking station, further fastening is not necessary.



See section "5.4.2. Deliverable accessories"



Fig. 25: Attachment point at the front



Fig. 26: Attachment point at the rear

### 13.3 *Fasten the seatbelt in a moving vehicle*

	<b>DANGER</b>
<b>Potential risk of injury or serious injury or death.</b>	
The Wheelchair integrated 3 or 4 point belts should not be relied on for occupant restraint in a moving vehicle. An approved, vehicle anchored safety belt system, should be used to secure occupant instead.	

	<b>DANGER</b>
Belt must not be held away from the body by wheelchair components such as armrests or wheels.	

	<b>DANGER</b>
Belt restraints should make full contact with the shoulder, chest and pelvic. Belts should be positioned low on the pelvis near the thigh-abdominal junction.	



Fig. 27: Illustration of improper belt-restraint fit

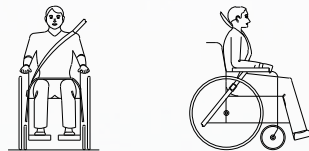

Fig. 28: Illustration of proper belt-restraint fit

### 13.4 Securing the wheelchair with a 4 point strap restraint system

Standard ISO 10542-1 tie down straps are only tested to 85 kg + user.

It is recommended to use with 4 point strap restraint system rated for the total weight of the wheelchair including any option, 2 at front and 2 at the back that conforms to ISO 10542-1.

If using a standard 4 point WTORS for securing a wheelchair heavier than 85 kg, use 6 straps to secure the wheelchair, 2 straps at the front and 4 straps at the back.

Recommended angle for tie down straps.

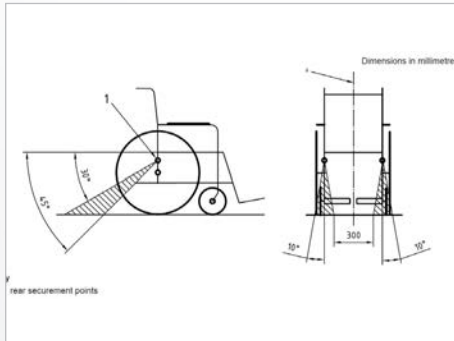

Fig. 29: Rear securement points

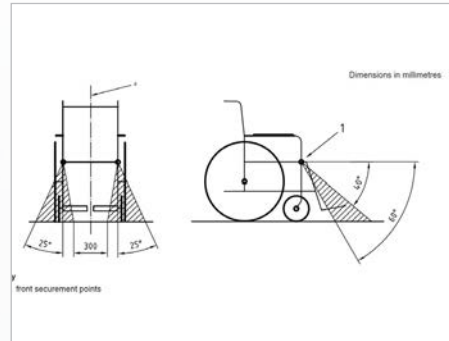

Fig. 30: Front securement points

## 13.5 Occupant restraint instruction

- Use a vehicle anchored occupant restraint system to secure the occupant.
- Both pelvic and upper torso restraint belts must be used to restrain the occupant to reduce the possibility of head and should not be held away from the body by wheelchair components such as armrest or wheels.
- Restraints should be mounted to appropriate vehicle pillar and should not be held away from the body by wheelchair components such as armrest or wheels.

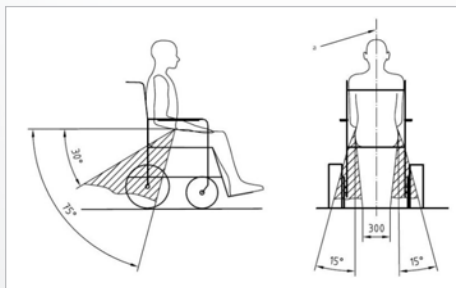

Fig. 31: Positioning the occupant restraint with 4 point strap system



### WARNING

Positioning the occupant restraint with 4 point strap system

- Pelvic restraint belt must be worn low across the front of the pelvis so that the angle of the pelvic belt is within the preferred zone of 30° - 75° to the horizontal.

- The upper torso restraint belt must fit over the shoulder and across the chest as illustrated Fig. 47. Restraint belts must be adjusted as tightly as possible consistent with use comfort.
- Restraint belt webbing must not be twisted when in use.
- Care should be taken when applying the occupant restraint to position the seatbelt buckle so that the release button will not be contacted by wheelchair components during a crash.

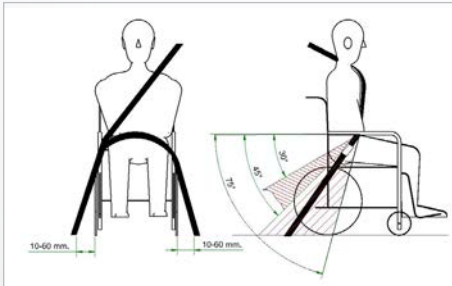

Fig. 32: Positioning the occupant restraint for use with dahl docking system only



## WARNING

Positioning the occupant restraint for use with Dahl docking system only

- When using wheelchair with Dahl docking system, the floor anchorage points for occupant restraint should be located 10 - 60 mm outside wheels, on each side. The pelvic belt must be worn low across the front of the pelvis - so that the angle of the pelvic belt is within the optional or preferred zone of 30° - 75°. As shown a steeper (greater) angle within the preferred zone, 45° - 75° is desirable i.e. closer to, but never exceeding 75° degrees.

## 13.6 Dahl Docking Systems Assembly

According to ISO 7176-19:2008, the Dahl Docking Station MK II and VarioDock™ are suitable for power wheelchair models PR50, PR Piccolino, PR Biolution and PR Heavy Duty from Paravan.

The following instructions explain how to assemble the Dahl Docking Station MK II and VarioDock™ on the wheelchair, using the PARAVAN adaption kit. Please also refer to Dahl Engineering's instructions for vehicle installation, use and maintenance.



The operation of the electric wheelchair without faults or malfunctions can only be guaranteed if the knowledge gained from these assembly instructions is observed and implemented. PARAVAN GmbH assumes no liability or warranty for damage or operating faults resulting from non-compliance with these assembly instructions or from modifications to the electric wheelchair.



Fig. 33: Dahl docking system



## WARNING

**Risk of injury** through incorrect handling of the batteries.

**Damage to property** through incorrect handling of the batteries.

- > Handle with special care.
- > May only be connected and disconnected by qualified personnel.
- > Keep away from fire.
- > Dispose of damaged batteries properly.



### 13.6.1 Content of Dahl docking stations

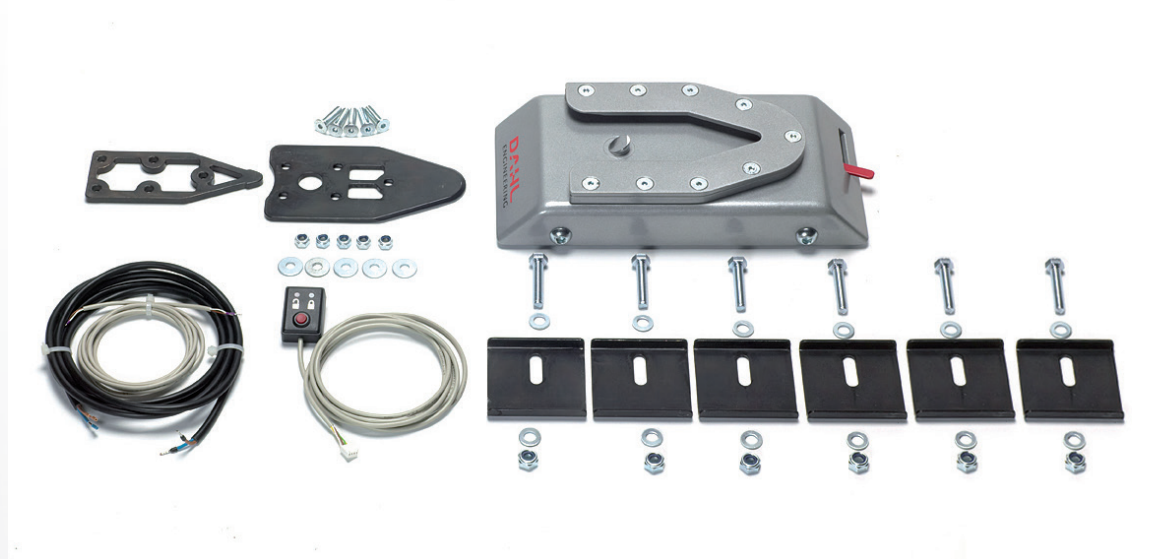

Fig. 34: Content of Dahl Docking Station MK II standard set # 501750



Fig. 35: Content of Dahl VarioDock™ standard set # 503600

## 13.6.2 Attaching the Dahl locking plate to the wheelchair

An additional wheelchair-specific adaptation kit is required for mounting the Dahl locking plate. It contains special nuts and plastic spacers to be fitted inside the battery box.

### **DAHL Docking Station Installation Kit Locking Plate 503125 (PV art. no.: 000043535) and DAHL adaptation set for DAHL Docking station 502064 (PV art. no.: 000044508):**

- ① Countersunk screw with Torx TX27 - ISO 14581 M8x35 14.9 (PV art. no.: 000043534)
- ② Locking plate with screws for docking station 10069 (PV- Art.-No.: 000020667)
- ③ 8 mm intermediate piece for locking plate for 10069 DAHL (PV art. no.: 000010131)
- ④ DAHL spacer 502071 (PV art. no.: 000044507)
- ⑤ DAHL nu 500759 (PV-Art.-Nr.: 000044506)

To install the Dahl locking plate, use the DAHL Adaptation kit, article 502064.

- > To mount the adapter set you need a Torx wrench TX 27. Tighten the Torx screws with a torque of 16-18 Nm.

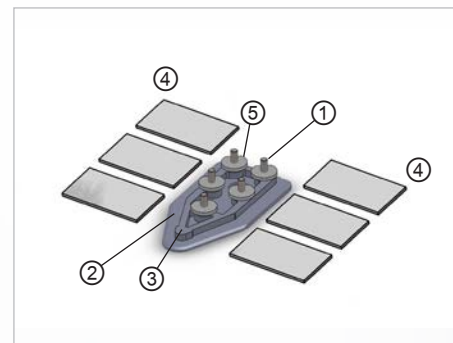

Fig. 36: Dahl Adaptationkit for Dahl Docking Station



Fig. 37: Torx TX 27

The cover must first be removed to attach the Dahl docking station to the Paravan wheelchair.

- To remove the cover, loosen the six knurled screws ①. If a main disconnect switch is installed on the rear panel, first remove the key of this switch ②.
- Remove the rear fairing ③, as well as the side fairings. The order in which these are removed is not important.
- To open the cover of the battery box, the two front hexagonal screws must be removed with a wrench with a width across flats of 10mm. Afterwards the battery box can be tilted backwards over the hinges - caution: here the whole weight of the structure rests on the lid!

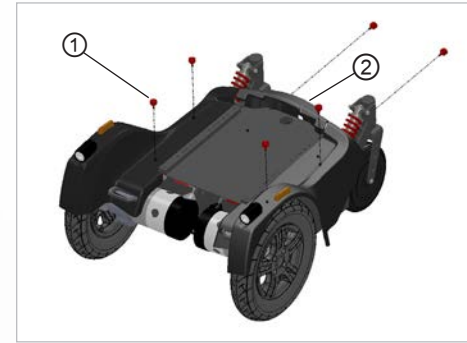

Fig. 38: Knurled screws Paravan

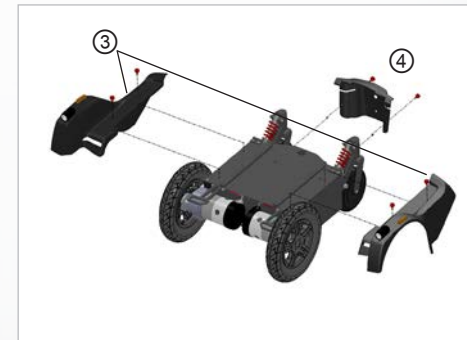

Fig. 39: Rear and side covers Paravan

### 13.6.3 Attaching the Dahl locking plate to the wheelchair

#### Removing the batteries:

- > Disconnect the main cable plug on the left and right side of the batteries.
- > Remove the left and right batteries.



Fig. 40: Main cable battery

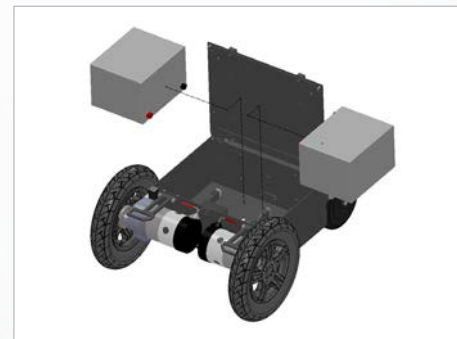

Fig. 41: Removing the batteries

## Mounting DAHL system:

- Position the locking plate 503125 on the bottom of the wheelchair. The holes for positioning are already provided in the battery box.
- Fasten the locking plate inside the battery box with the adaptation set 502064 and screw the five countersunk screws from below with the DAHL nuts 500759. Adjust the height of the locking rail (1.2).
- Additional intermediate pieces (1mm, 2mm, 3mm, 8mm, 10mm) may be required. The fine adjustment is done when adjusting the wheelchair at the DAHL docking station in the vehicle. Finally, glue the six spacers 502071 to the bottom of the battery box so that the batteries lie flat when inserted and cannot slip.
- Once you have adjusted the height of the locking rail, screw in the pan-head screws medium tight with a screw lock. If using the power height adjustable Dahl VarioDock, additional spacers will not be needed for adjusting the height.

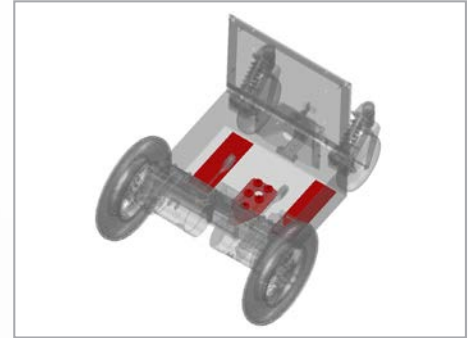

Fig. 42: Position of the Dahl system

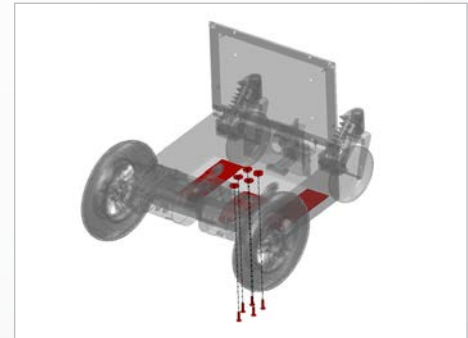

Fig. 43: Fastening of the Dahl system

After the Dahl system has been attached to the wheelchair chassis, reinsert the batteries and reattach the panelling in reverse order.



The PARAVAN adapter kit can also be pushed further forwards or backwards and fastened accordingly, depending on the position of the counterpart in the vehicle.



Installation of the Dahl Docking systems in the vehicle: Only professional companies in the business of converting or building wheelchair accessible vehicles can order the docking system from Dahl Engineering. A qualified and experienced technician must carry out the installation. Dahl Engineering can provide vehicle specific installation instructions for a large range of vehicles, which must be respected by the fitter. Please contact Dahl Engineering for further information about approved vehicles and fitting positions.

To attach the Dahl Docking Station to the PR 40, use the screws provided.

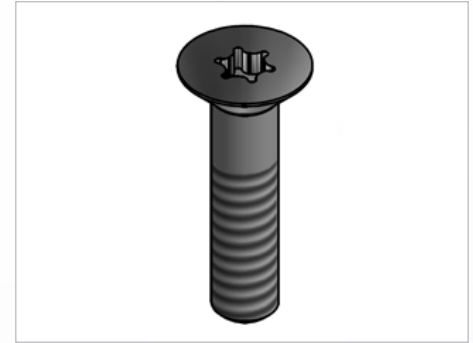

## DANGER

**Potential risk of injury or serious injury or death due to use of incorrect screws.**

- > Use the screws provided.
- > Do not use any other screws than those supplied from Dahl Engineering (part no. 502800 which is quality 14.9 with torx 27 key). Standard screws will not be strong enough in the event of a collision.



### 13.6.4 Description of the Dahl Docking system functions

- ① Dahl Docking station
- ② Lock plate and spacer
- ③ Lock pin
- ④ Red LED
- ⑤ Green LED
- ⑥ Control panel
- ⑦ Release button
- ⑧ Manual emergency release lever
- ⑨ Manual operating lever

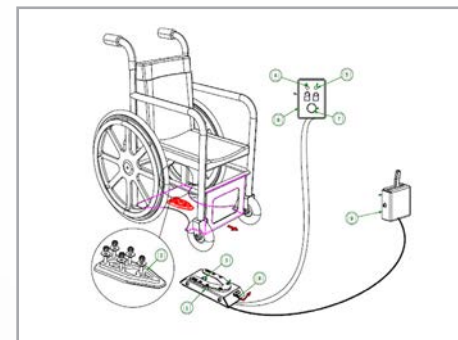

Fig. 44: System functions Dahl



Please refer to Dahl Engineerings installation and user guide for height adjustable VarioDock™ system.

## 13.6.5 Securing the wheelchair in the docking station

- Maneuver the wheelchair slowly and in a uniform direction over the docking station. The lock plate under the wheelchair helps to guide the wheelchair into place in the docking station. When the lock plate is fully engaged in the docking station, a spring-action locking pin automatically secures the lock plate.
- The docking station is equipped with a control switch that indicates whether the lock plate is correctly secured in the docking station. As soon as the lock plate comes into contact with the locking pin, a warning tone will sound (a high-pitched howl), and the red diode/lamp (LED) in the control panel will light up until the lock plate is either fully engaged or else the wheelchair is removed from the docking station.
- As an indication that the wheelchair is properly secured, the warning tone will cease, the red lamp (LED) in the control panel will go out and the green lamp (LED) will light up.
- Do not forget to buckle up for driving.



Please refer to Dahl Engineering's installation and user guide for height adjustable VarioDock™ system.



## DANGER

**Potential risk of injury or serious injury or death! Do not move the vehicle:**

- > Whilst the wheelchair is being maneuvered into position in the docking station
- > If the wheelchair and user are not correctly secured.
- > If the warning tone sounds and/or the red warning lamp (LED) in the control panel flashes or is lit!

Always check if the lock plate is properly engaged in the docking station by trying to reverse the wheel chair out of the docking station before moving the vehicle. (It must not be possible to reverse out of the docking station without pressing the red release button in the control panel).

## 13.6.6 Release from the docking station

- When the vehicle has been brought to a halt, remove the safety belt.
- To unlock commence by driving the wheelchair forward to release pressure on the lock pin.
- Press the red release button in the control panel. The locking pin will be triggered/ released for approx. 5 or 8 seconds, after which the locking pin is automatically locked/activated again.
- Move the wheelchair away from the docking station within this 5 or 8 second period. Do not attempt to reverse out of the docking station until the red LED on the control module, which indicates the unlock position, has been illuminated.



Please refer to Dahl Engineerings installation and user guide for height adjustable VarioDock™ system.



### WARNING

Attempting to reverse the wheelchair before the red LED has been illuminated will result in blocking the docking stations locking mechanism, which makes it impossible to reverse. If this happens repeat above unlocking procedure.

### 13.6.7 Manual release in case of electric failure

A manual emergency release is located at the front edge of the docking station.

- Move wheelchair forward to remove the pressure on the lock pin and push the red release arm to one side and hold it there while the wheelchair moves away.
- A cable-activated manual operating lever can also be fitted (accessory). The red release arm is also pushed to one side and should be held there whilst the wheelchair moves away.

If the described manual release procedures fails, an emergency release tool made from red plastic comes with each docking station.

- Move wheelchair forward to remove the pressure on the lock pin
- Place the emergency release tool in the gap between the locking plate and the docking station.
- Push the release tool and wheelchair forward until the locking pin has been forced down - after which the wheelchair can reverse out of the docking station.
- Please also refer to Dahl Engineering instructions for installation, use and maintenance for Dahl Docking Station MK II and VarioDock™ systems.

*Loading and transporting the power wheelchair*



Fig. 45: Manual release step 1

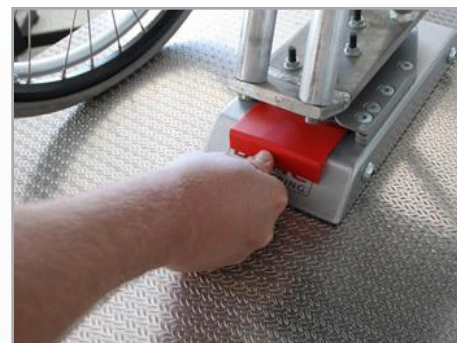

Fig. 46: Manual release step 2

## 14. Controls

### 14.1 Control panel R-NET CJSM2

#### 14.1.1 Overview of the control elements



Fig. 47: Control panel R-NET CJSM2

With the control panel (joystick) built into your power wheelchair, you can control all of the power wheelchair's driving, steering and braking processes. All additional functions which are equipped with displacement motors, such as the lifting arm and the sitting functions, must also be operated via the control panel.

- > "On/off" key ① Selection of profile (movement levels)/mode (seat functions)
- > "Direction indicator, right/left" keys ②
- > LCD diagnostic LED brightness sensor ③
- > Display ④ (colour)
- > MODE key ⑤ for switching function – drive program/seat functions
- > PROFILE key ⑥ (selection of movement levels)
- > Joystick ⑦ (determines direction of travel)
- > "Horn" key ⑧
- > Function key ⑨ for selecting/drilling down to movement levels
- > "Hazard lights" key ⑩
- > "Light" key ⑪
- > Charging status indicator for storage battery ⑫

## 14.1.2 Status display

The function keys are used to select the specific functions displayed in the assigned fields on the display.

Symbols of the status indicator:

- > Charging status of the storage batteries ①
- > Direction indicator, left ②
- > "On/off" light ③
- > System status ④ ("tortoise" → speed control active)
- > Direction indicator, right ⑤
- > Time ⑥
- > Hazard lights "on/off" ⑦
- > Current seat function / Current driving profile ⑧



Symbols ② + ⑤ play an active part in the "hazard lights" function!



Fig. 48: Function keys



Fig. 49: Status display

### 14.1.3 Start, switch off



Fig. 50: Speed control (tortoise) active

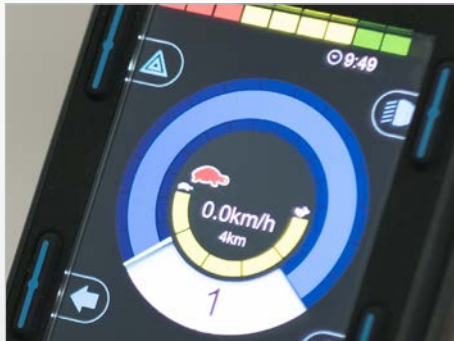

Fig. 51: „On / off“ key

#### Start

Push the "on/off" switch ① upwards.

- > The status display briefly flashes and the last selected function in terms of movement level / seat function is shown.
- > Press the switch ① downwards again to:
  - > - Select movement levels 1 to 5
  - > - Then switch to the seat functions

#### Switch off

Push the "on/off" switch ① upwards.

- > The power wheelchair switches itself off (assuming it is already switched on).



### 14.1.5 Switch direction indicator on and off

Press key ① or ② for the respective direction indicator, left or right.

- The selected direction indicator will flash.
- Press once more → direction indicator switches off.



Fig. 53: Turn signal right / left

### 14.1.4 Switch light on and off

Press the key ① for the "light on" function.

The lighting installation switches itself on and the light symbol lights up blue.

Press once more:  
→ Light off



Fig. 52: Light on and off



Fig. 54: light symbol (colour)

## 14.1.6 Switch hazard lights on and off

Press the "hazard lights" key ① for the "hazard lights on" function.

- The hazard lights switch themselves on, while the hazard lights symbol flashes red and both direction of travel symbols flash green.
- Press the key again → The hazard lights / hazard lights symbol switch themselves off.



Fig. 55: Hazard lights on / off

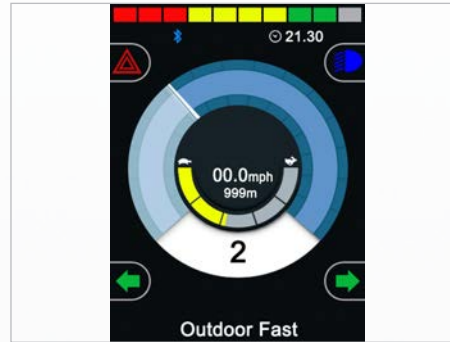

Fig. 56: Symbols (colour)

## 14.1.7 Driving functions overview



Fig. 57: Driving functions



Fig. 58: Charging status indicator (driving function blocked)

Overview of the driving functions shown on the display of the control panel during driving, steering and braking actions of the power wheelchair.

- > Selected drive program/movement level ①
- > Respective setting (having drilled down) for the selected movement level (1 to 5) fast/slow ②
- > ③ (Profile) key for switching to a higher or lower drive program (1 to 5).
- > Key ④ to change speed in the drive program. Drilling down the respective drive program.
- > Display of the current speed (km/h) ⑤
- > "Trip" display in kilometres ⑥

Display turns black when a charging device is connected.

- > If the wheelchair is switched on, the charging status indicator is the only thing shown.
- > First connect the charging lead for the charging device at the joystick, then plug the power cable for the charging device into the socket.



If the power wheelchair is being charged via the charging socket on the control panel, driving mode is automatically blocked.

## 14.1.8 Select drive program, drive

The power wheelchair must be in driving mode.

- The last selected drive program is shown on the display (profiles 1 to 5). Drive profiles 1 to 5 are further divided into 5 levels once you drill down.

Press the switch upwards ① or downwards ② to switch to a higher or lower sub-level.

- The selected drive program and sub-level will appear on the display.

Push the joystick in the direction in which you wish to travel.

- The power wheelchair moves in the selected direction.

- ① Move forwards
- ② Turn to the right
- ③ Move backwards
- ④ Turn to the left



See section "3 Safety notes"



Fig. 59: Select drive program



Fig. 60: Joystick travelling direction

## 14.1.9 Electrical seat adjustment



Fig. 61: Example: Display of seat functions

Use the MODE key to switch from the drive program to the seat functions. Select the desired seat function by moving the joystick “← left/right →”.

> The adjustment functions menu will appear on the display.



Only the released or available functions can be selected.

To make the desired setting:

adjust the seat, seat position, backrest, tilting of seat, angle for legs and lying/standing function via the joystick (by moving it forwards or backwards).

Switch back to the drive program with the Profile key.

> The power wheelchair is ready to drive.



See section "3 Safety notes"

### 14.1.10 Set time/date

Press and hold the "hazard lights" key to access the "Settings" menu.

> The special functions menu will appear on the display.

Move the joystick → left/right to access the options "year, month, date, day of the week, hours and minutes". Select the desired option by moving the joystick "← left/right →".

Move the joystick "↑ up/down ↓" to select exactly the setting you want. To save and quit the menu, go to "Quit" and close it by moving the joystick "↑ up/down ↓".



Fig. 62: "Set time" function menu



Fig. 63: Setting the time and date

### 14.1.11 Show/hide clock, configure 12h/24h display



Fig. 64: Set clock to visible/invisible

Select the program function:

- > Press and hold the "hazard lights" key.
- > The "Settings" menu appears.
- > Use the joystick to select "Set time". Move the joystick "← left/right →".
- > Select "12h/24h display" or "Off" by moving the joystick "← left/right →".
- > To save → quit the program. Move the joystick "← left/right →".

### 14.1.13 Adjust display brightness

Select the program function:

- Press and hold the "hazard lights" key.
- Select "Back lighting" from the settings.
- Select the intensity of the lighting (0 to 100% in 10% stages) by moving the joystick "← left/right→".
- To save → quit the menu.

### 14.1.12 Adjust display brightness, automatic (recommended)



The display brightness is automatically adjusted to lighting conditions by the factory. Menu may be arranged slightly differently, depending on the software version.

Select the program function:

- Press and hold the "hazard lights" key.
- Select "Auto Backlight" from the settings.
- Select "On/Off" by moving the joystick "← left/right →".
- To save, quit the menu.



Fig. 65: Setting the display brightness



Fig. 66: Autom. display brightness



### 14.1.14 Block the controls (with the wheelchair switched on)

- > Turn the control panel off and press and hold the ON/OFF button ① until you hear a beeping sound
- > Move the joystick forwards until you hear a beeping sound
- > Move the joystick backwards until you hear a beeping sound
- > Immobiliser is activated



Fig. 67: Blocking the controls

### 14.1.15 Release the controls (with the wheelchair switched off)

- > Switch on → and a "padlock symbol" appears .
- > Move the joystick forwards until you hear a beeping sound
- > Move the joystick backwards until you hear a beeping sound
- > The "Functions" menu is now available – the last function selected is shown



Fig. 68: Lock symbol

## 14.2 Control panel R-NET CJSM-L

### 14.2.1 Overview of the control elements



Fig. 69: Control panel R-NET CJSM-L

With the control panel (joystick) built into your power wheelchair, you can control all of the power wheelchair's driving, steering and braking processes. All additional functions which are equipped with displacement motors, such as the lifting arm and the sitting functions, must also be operated via the control panel.

- > "On/off" key ①
- > "Direction indicator, right/left" keys ②
- > Display showing the signal currently active (light, indicator) ③
- > Display ④ (colour)
- > MODE key ⑤ for switching function – drive program/seat function
- > PROFILE key ⑥ (selection of movement levels)
- > Joystick ⑦
- > "Horn" key ⑧
- > Function key ⑨ for selecting/drilling down to movement levels
- > "Hazard lights" key ⑩
- > "Light" key ⑪
- > Charging status indicator for storage battery ⑫

## 14.2.2 Status display

The function keys are used to select the specific functions displayed in the assigned fields on the display.

Symbols of the status indicator:

- > Charging status of the storage batteries ①
- > Direction indicator, left ②
- > "On" light ③
- > System status ④ ("tortoise" → speed control)
- > Direction indicator, right ⑤
- > Time ⑥
- > Hazard lights ⑦



Symbols ② + ⑤ play an active part in the "hazard lights" function!



Fig. 70: Function keys



Fig. 71: Status display

## 14.2.3 Start and switch off



Fig. 72: "On / off" key

### Start

Push the "on/off" switch ①.

- > The last selected function in terms of movement level / seat function is shown.

### Switch off

Push the "on/off" switch ①.

- > The power wheelchair switches itself off (assuming it is already switched on).



Fig. 73: Speed control (tortoise) active

### 14.2.4 Switch light on and off

Press key ① or ② for the respective direction indicator, left or right.

- > The selected direction indicator will flash.
- > Press once more → direction indicator switches off.



Fig. 75: Turn signal right / left

### 14.2.5 Switch direction indicator on and off

Press the key ① for the "light on" function.

The lighting installation switches itself on and the light symbol lights up blue. Press once more: "light off".



Fig. 74: Light on and off



Fig. 76: Light symbol (colour)

## 14.2.6 Switch hazard lights on and off

Press the "hazard lights" key ① for the "hazard lights on" function.

- The hazard lights switch themselves on, while the hazard lights symbol flashes red and both direction of travel symbols flash yellow.
- Press the key again → The hazard lights / hazard lights symbol switch themselves off.



Fig. 77: Hazard lights on / off



Fig. 78: Symbols (colour)



## 14.2.7 Driving functions overview



Fig. 79: Driving functions

Overview of the driving functions shown on the display of the control panel during driving, steering and braking actions of the power wheelchair.

- > Selected drive program/movement level ①
- > Maximum speed in the selected drive program ②
- > Key ③ to switch to a higher (+) or lower (-) drive program
- > Key ④ to change speed in the drive program
- > Display showing "trip" in kilometres and current speed (km/h) ⑤

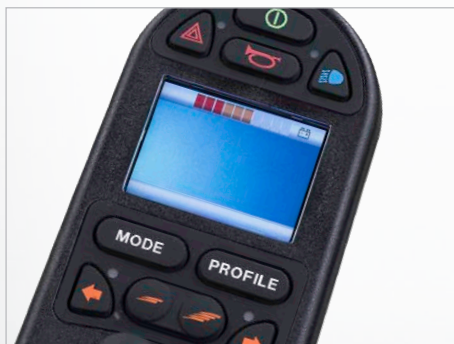

Fig. 80: Driving function blocked

Display is blank when a charging device is connected.

- > If the wheelchair is switched on, the charging status indicator is the only thing shown.
- > First connect the charging lead for the charging device at the joystick, then plug the power cable for the charging device into the socket.



If the power wheelchair is being charged via the charging socket on the control panel, driving mode is automatically blocked.

## 14.2.8 Select drive program, drive

The power wheelchair must be in driving mode.

- The last selected drive program is shown on the display.

Press the profile key ① to select/switch to one of the 5 movement levels (profiles).

- The selected drive profile will appear on the display.

Press the relevant key to select a higher ② or lower ③ maximum end speed in the respective drive profile.

- The preference within the drive profile will appear on the display.

Push the joystick in the direction in which you wish to travel.

- The power wheelchair moves in the selected direction.

- ① Move forwards
- ② Turn to the right
- ③ Move backwards
- ④ Turn to the left



See section "3 Safety notes"



Fig. 81: Select drive program



Fig. 82: Joystick travelling direction



## 14.2.9 Electrical seat adjustment



Fig. 83: Display of seat functions

Use the "Mode key" to switch from the drive program to the seat functions. Select the seat function by moving the joystick "← left/right →".

> The respective seat function will appear on the display.



Only the released or available functions can be selected.

Adjust the seat via the joystick (push forwards or backwards).

> The seat carries out the desired function.

Switch back to the drive program with the mode key.

> The power wheelchair is ready to drive.



See section "3 Safety notes"

## 14.2.10 Set time/date

Press and hold the "slower" ① and "faster" ② speed keys to access the "Settings" menu.

> The special functions menu will appear on the display.

Move the joystick → right to access the options "year, month, date, day of the week, hours and minutes". Select the desired option by moving the joystick "← left/right →".

Move the joystick "↑ up/down ↓" to select exactly the setting you want. To save and quit the menu, go to "Quit" and close it by moving the joystick "↑ up/down ↓".



Fig. 84: "Set time" function menu



Fig. 85: Setting the time and date

## 14.2.11 Show/hide clock, configure 12h/24h display



Fig. 86: Set clock to visible/invisible

Select the program function:

- > Press and hold the keys ①+②
- > The "Settings" menu appears.
- > Use the joystick to select "Display time".
- > Select "12h/24h display" or "Off" by moving the joystick "← left/right →".
- > To save → quit the program.

## 14.2.12 Adjust the display background and brightness

Select the program function:

- Press and hold the "slower" ① and "faster" ② speed keys.
- Select "Back lighting" from the settings.
- Select the intensity of the lighting (as a percentage) by moving the joystick "← left/right →".
- To save → quit the menu.

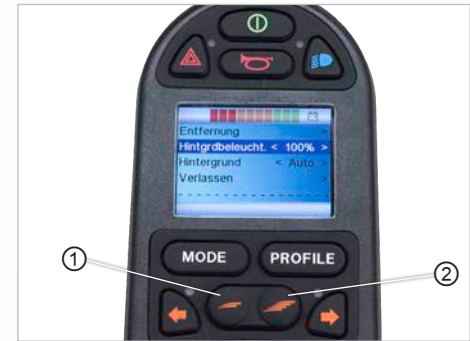

Fig. 87: Setting the display brightness

## 14.2.13 Adjust display brightness

Select the program function:

- Press and hold the "slower" ① and "faster" ② speed keys.
- Select the preferred option by moving the joystick "← left/right →".
- To save, quit the menu.

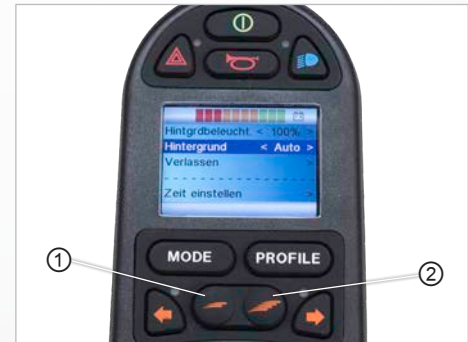

Fig. 88: Setting the display background

### 14.2.14 Block the controls (with the wheelchair switched on)

- > Turn the control panel off and press and hold the ON/OFF button ① until you hear a beeping sound
- > Move the joystick forwards until you hear a beeping sound
- > Move the joystick backwards until you hear a beeping sound
- > Immobiliser is activated



Fig. 89: Blocking the controls

### 14.2.15 Release the controls (with the wheelchair switched off)

- > Switch on → and a "padlock symbol" appears .
- > Move the joystick forwards until you hear a beeping sound
- > Move the joystick backwards until you hear a beeping sound
- > The "Functions" menu is now available – the last function selected is shown.



Fig. 90: Controls blocked – block symbol

## 15. **Moving out of the PR 40 seat**

For your own safety, the instructions below must be followed in order to enable you to move out of the PR 40 independently:

- You should be able to safely carry your own weight.
- You should be able to push yourself off from the PR 40 with both arms simultaneously using the same amount of strength.
- You should have a safe position to support yourself, one from which you cannot slip.
- You should have practised everything often enough in the presence of another person.
- You should consider all eventualities in case you fall on the floor and there is no one present with you.



We recommend that you enlist the help of another person. However, you should point out the dangers to this person. In all cases, discuss the implementation process together. Never support yourself on the control panel, the PR 40 could be accidentally activated and would then start following uncontrolled commands.



If you want to move to the seat of another PR 40, the brake lock release lever must be set to "**LOCK**" (upwards) and the PR 40 must be switched off.



See section "12.9.1 Operation of the brake lock release lever (emergency release)"

## 15.1 Procedure when moving sideways out of the seat

When moving sideways out of the seat, proceed as follows:

- Position the PR 40 sideways
- Adjust the seat to the required height
- Turn off the PR 40
- Fold up ① footrests
- Swing ② armrest upwards
- Move from the seat



Fig. 91: Move from the seat, footrests



Fig. 92: Move from the seat, armrest

## 16. **Maintenance and servicing**

General

Information

Prepare

Operate

Help

Technology

If you want to use and operate the PARAVAN PR 40 in line with its intended purpose, you need to comply with the recommended annual maintenance plan that was designed for the power wheelchair. All driven parts and in particular the functional unit are designed to ensure low-maintenance and fault-free operation of the PR 40.

However, in order to guarantee its perfect functioning, the PR 40 must nonetheless:

- > be handled with care,
- > be kept clean,
- > be serviced periodically on an annual basis.

### 16.1 **Service partner**

If problems occur, please contact your medical supply store or your dealer, or PARAVAN GmbH directly.



In order to have maintenance work carried out, please contact your medical supply store or your dealer, or PARAVAN GmbH directly. Maintenance and servicing works must only be carried out by trained persons.



## 16.2 *Cleaning and care*



Never use a high-pressure cleaner to clean the PR 40. Avoid contact of the electronic parts with water.

To clean the frame and the plastic components (lacquer set), only

➔ mild soapy water without scouring agents

may be used.

Commercial surface disinfectants

➔ can be used for the disinfection of

➔ covers, the seat and the back cover

.

## 17. *Disposal and environmental protection*

General

Information

Prepare

Operate

Help

Technology

The PR 40 itself and its individual components are technically durable. In most cases, recyclable and harmless raw materials are used for its design and manufacture. After it has been decommissioned, the PR 40 is ideally suited to undergo proper recycling processes and environmentally friendly disposal procedures.



National and regional waste disposal provisions must be complied with.

The PR 40 can be dismantled into the following main parts for the purpose of recycling:

- > metals,
- > plastic or composite materials,
- > electronic waste,
- > storage batteries.

A top-end recycling procedure in accordance with the type and character of the waste should be sought ("Closed Substance Cycle and Waste Management Act"). This is economically viable if the costs associated with recycling are not disproportionate to the costs which would be incurred for waste disposal.

## 17.1 Packaging material

The packaging consists of largely recyclable material which is harmless to the environment, such as:

- > wood, e.g. pallets or outer packaging,
- > metal, e.g. tightening straps,
- > bubble wrap.



Take advantage of the opportunity to recycle the packaging in an environmentally-friendly way. Recycling of rubbish should take priority over its disposal.

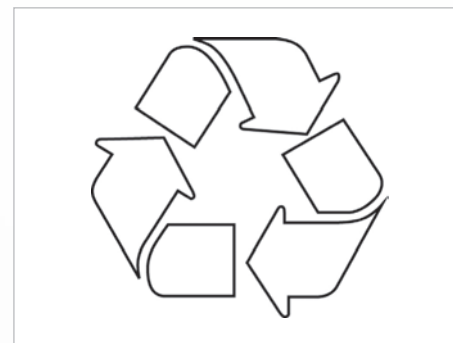

Fig. 93: Recycling

## 17.2 **Recommissioning**

If the PR 40 has been out of service for a long time, the following steps must be carried out before it is re-commissioned:

- > check protective devices, repair if necessary,
- > complete maintenance or review,
- > complete cleaning.



Before it can be operated again, the PR 40 must be completely cleaned and approved for use after a thorough inspection by a service technician authorised by PARAVAN GmbH.



See chapter “17 Maintenance and servicing”

### 17.3 *Information regarding transfer of the product*

If you give or sell the PARAVAN PR 40 standing wheelchair to another person, you must also pass on all the necessary technical documents for safe handling and operation, such as:

- > operating instructions,
- > proofs of maintenance

to the new user.



See chapter “17 Maintenance and servicing”

# 18. Troubleshooting

## 18.1 Status indicator on the control panel

Error message	Meaning
Centre joystick / Joystick zentrieren	The most common cause of this error is that the joystick is not centred when the control system is switched on. "Joystick off-centre" will appear on the display for five seconds. If the joystick is not released within this time, an error will be generated. Please ensure that the joystick is centred and then switch the control system on. When switching on the control system, make sure that you do not touch the joystick button with your hand.
Low battery / Batteriestand niedrig	This message appears when the control system detects that the battery voltage has dropped below 16 V. Check the state of the batteries and the connections in the control system. High battery / Hohe Batteriespannung This message appears when the control system detects that the battery voltage has risen above 35 V. The most common reason for this is that you have overcharged the battery or there is a bad connection between the control system and the batteries. Check the state of the batteries and the connections in the control system.
System lock active / Sperre aktiv	This message appears when one of the blocking inputs is active and locked. Switch the control system off and on again. This will remove the system lock and may get rid of the error. Check all cables and switches on the corresponding blocks.

General

Information

Prepare

Operate

Help

Technology

<b>Error message</b>	<b>Meaning</b>
Brake error / Bremsen	<p>This message appears when the control system detects a problem with the magnetic brakes or their connections.            Check the magnetic brakes, cables and connections in the control system.            Check that the motor brakes have not come uncoupled.</p> <p>Motor error / Motorfehler            This message appears when the control system detects that the connection to a motor has been interrupted.            Check the motors, cables and connections in the control system.</p>
Gone to sleep / Ruhemodus	<p>This message appears when the control system has been inactive for longer than the [time] period defined by the "SleepTimer" parameter.</p> <p>Gyro disconnected / Gyro ni. angeschl            This message appears when the control system detects that the gyro module is no longer connected.            Reconnect the gyro module and restart the system.</p> <p>Bad cable / Kabelfehler            This message appears when the control system detects an error in the cabling that enables the modules to communicate with one another.            Check whether the cables or connections have been interrupted or squashed/jammed.            If there is any visible damage to the cables, replace them and switch the control unit off and on again. Please speak to customer service about any replacements you may need.</p>

## 19. **Electrical system**

### 19.1 **Automatic fuses**

The PARAVAN PR 40 standing wheelchair is equipped with an automatically triggering fuse and an overload protection device. These are described in more detail below:

- > **Main fuse:** This protects the complete electrical system in the event of overloading by PR 40 electrical consumers – the response is an instant and complete electrical shut-down of the entire power wheelchair.



See section "20.2 Main fuse"

- > **Overload protection:** The power generated during downhill travel is diverted into the storage batteries. If the storage batteries were already charged, the safety system switches to emergency stop.



See section "20.3 Overload protection"



## 19.2 Main fuse



The main fuse is located at the rear of the power wheelchair.



An active (triggered) main fuse is indicated by the swung out green lug.

### 19.2.1 Resetting a triggered main fuse

- > Push the lug ① of the active main fuse ② back into its original position ③. & The lug must audibly or visibly lock into place.
- > The PR 40 is ready for operation again.

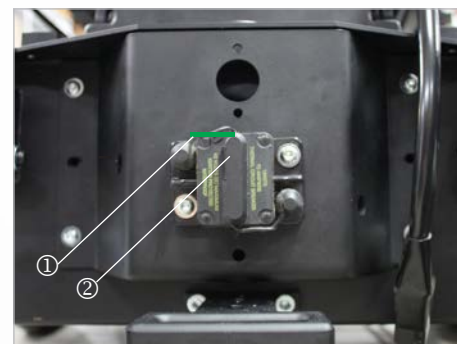

Fig. 94: Main fuse, active

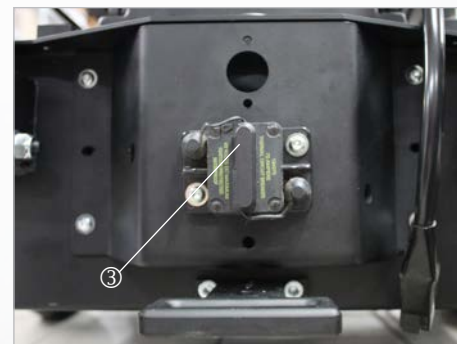

Fig. 95: Main fuse

## 19.3 **Overload protection**



While travelling downhill, the generated power is diverted into the storage batteries – the drive motors work like a generator in this case. If you have fully charged your PR 40 before travelling downhill, the security system switches to emergency stop in order to avoid damage to the electrical system (control, electronics, etc.).



Active (triggered) overload protection is indicated by gradual braking until the PR 40 comes to a standstill.

### 19.3.1 Reset the triggered overload protection:

- Switch on the power generators, e.g. lighting. The generated excess power is now immediately used again.
- The PR 40 is ready for operation again.

## 19.4 Connection option for auxiliary units



The PARAVAN PR 40 offers the option of connecting different auxiliary units with a voltage of 12 volts or 24 volts to the PR 40 on-board power supply.

If you require special equipment (e.g. a respirator) for this connection, please contact PARAVAN GmbH. The external connections are individually adjusted for the respective consumer and the cable harness is cut to size or moved in position.

## 19.5 The lighting installation

The PARAVAN PR 40 is equipped with a lighting installation featuring LED technology that is fully approved for road traffic. Due to the LED lamps used, the wearing out or maintenance of this installation is practically impossible/unnecessary.

To switch on the lighting installation, proceed as follows:

- > Select menu in the control unit.
- > Switch on the lighting installation.



See section "15 Control"

Parts of the lighting installation:

- > LED front headlamps ①
- > LED direction indicator ②
- > LED rear light ③



Fig. 96: Illumination at the front



Fig. 97: Illumination at the rear

## 19.6 *Maintenance-free storage batteries*

Your PARAVAN PR 40 is equipped with high quality and powerful storage batteries. These maintenance-free storage batteries are completely sealed. Refilling or topping up the electrolyte (battery acid) is therefore not intended or possible.

The charging status or the capacity of the storage batteries can be read on the control panel.

- > Red zone: low capacity, immediate recharging necessary.
- > Yellow zone: energy is still sufficient, recharging if the opportunity arises.
- > Green zone: Storage battery fully charged, full capacity.



See section "15 Control"



See section "20.8 Charging the PR 40"

## 19.7 **Information regarding storage batteries**

General

Information

Prepare

Operate

Help

Technology



Sealed storage batteries must never be opened. Opening the storage batteries will result in irreparable damage to them and could lead to a complete power failure.



See section "22.1 Handling sealed storage batteries"



The storage batteries must be recharged after every use (even if they have only been minimally discharged) with the supplied charger. Always connect the charger during periods of non-use of the power wheelchair. The supplied charger automatically switches to "trickle charging" and thus guarantees continuous full use of the storage battery's functions. If you leave the storage batteries uncharged for too long they will deeply discharge and recharging will no longer be possible, meaning the battery should be replaced.



See section "20.8.2. Charger"



When disposing of storage batteries, please observe the current regulations relating to waste disposal. For information regarding these, please contact the responsible city council or municipal authority, or contact a disposal company directly.



See section "18 Disposal and Environmental Protection"

## 19.8 Charging the PR 40



Only charge the storage batteries with the charger supplied by us.

### Care tips:

- > Always ensure that the storage batteries have full charging capacity.
- > Daily overnight charging is recommended.
- > The PR 40 should be charged for at least 8 hours uninterrupted.
- > The charging cycle ends when the green lamp is lit up.
- > Always connect the charger during periods of non-use (trickle charging).



If you observe these care tips, the performance and service life of the storage batteries will be maximised.



See section "20.6 Maintenance-free storage batteries"



See section "20.7 Information regarding storage batteries"

## 19.8.1 Procedure for charging the PR 40

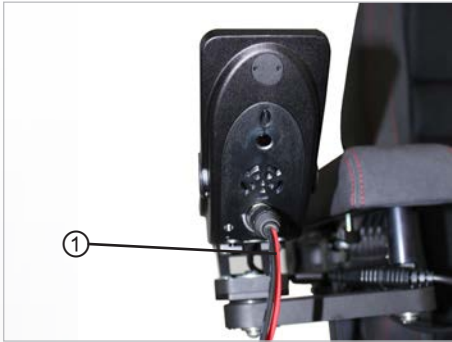

Fig. 98: Plug in the charging cable

- > Turn off the PR 40.
- > Put the charger on a heat-insensitive surface, e.g. on the footrests.
- > Put the charger plug ① into the charging socket on the control panel.
- > Connect the charger to the power supply & The charging process starts.
- > Check the charging status. & Are the storage batteries at full capacity? The charging process is complete.
- > Disassembly in reverse order.



Terminate the connection between the power at the power socket and the charger.



## 19.8.2 The charger

The purpose of the charger is to automatically charge the storage batteries. The charger is housed in splash-proof sheet-steel casing. It complies with the guidelines and protection requirements of the:

- > Low Voltage Directive 2006/95/EC,
- > Electromagnetic Compatibility Directive 2004/108/EC.



Read the operating instructions included separately with the charger.

## 19.8.3 Installing the charger, installation location

- > Only install in dry rooms.
- > Do not cover casing openings.
- > Ensure sufficient ventilation.
- > Do not install near to radiant heaters (e.g. under lamps, on heaters etc.)



During the charging process, put the charger on the foot supports of the wheelchair.



Fig. 99: Set up charger

## 20. *Technical equipment*

### 20.1 *Technical data and measurements*

<b>Wheelchair versions</b>	
PR 40	140 to 190 cm body height
<b>Seat adjustment</b>	
Seat height	370 to 570 mm
Seat angle forwards (standing function)	90°
Seat angle backwards (tilting)	45°
Backrest angle	8° to 85°
Foot support angle	0° - 90°
<b>Main dimensions</b>	
Width	640 mm
Length	1200 mm
Length (footplates folded up)	960 mm

General

Information

Prepare

Operate

Help

Technology

<b>Other special features</b>	
Puncture-proof tyres	Fold-up footplate
Independent leaf spring rear suspension	Footrests with length compensation
Compatible with DAHL docking station	Controls: R-Net
Individual seat pad adjustment	Maintenance-free gel batteries
<b>Electrical equipment</b>	
Storage batteries	2 x 12 Volt / 85 Ah / C20
Lighting	LED direction indicators LED front and rear lights
Range	Approx. 30 km
<b>Chassis / tyres</b>	
Spacer width at the drive axle	640 mm
Spacer width at the rear axle	370 mm
Wheelbase	650 mm
Measurements of front wheel	3.00 - 8 clearance
Measurements of rear wheel	2.50 - 3 clearance

<b>Seat features</b>	
Seat width	36 - 46 cm
Seat depth	39-52 cm
Backrest height	61 cm
<b>Driving features</b>	
Ground clearance	70 mm
Maximum obstacle clearance	60 mm
Turning circle	1400 mm
Maximum (upward) climb	12% / 4%**
Maximum (downward) slope / (sitting/standing)	12% / 4%**
Maximum camber (sitting/standing)	12% / 4%**
Speed (sitting/standing)	6km/h* or 10km/h (optional)*
<b>Weights</b>	
Unladen weight (version small / version medium, large)	188 Kg
Maximum load	140 Kg
<b>Operating conditions</b>	
Temperature	10° - 40°
Humidity	20% - 90%
* The maximum range was measured under test conditions. The actual range achieved may vary according to weight, terrain and weather conditions. The HMV version is limited to 6 Km/h.	

## Details regarding the pads on the arm supports, seat and rear, description of the frame

<b>Arm support pads</b>	
Pad material:	PV foam
Thickness:	20mm
Compression hardness:	7.2 kPa
Density:	56 kg/m <sup>3</sup>
Cover:	BC 12 / Floridas



<b>Seat pads</b>	
Pad material:	PR foam / MOI system
Thickness:	50 - 110 mm
Compression hardness:	-
Density:	340 +/- 25 N
Cover:	Matt black



The seat pad and backrest pad are moulded foam parts and are therefore not measurable in volumetric weight. Moulded parts are measured in accordance with DIN standards. Measurement is made in N.

## Details regarding the pads on the arm supports, seat and rear, description of the frame



<b>Back pads</b>	
Pad material:	PR foam / MOI system
Thickness:	30 - 50 mm
Compression hardness:	77 kg/m <sup>3</sup> ± 5%*
Degree of hardness:	340 +/-25 N*
Density:	260 +/- 25 N
Cover:	Matt black

\* These are not cut foam cuboids and are therefore foamed as moulded parts. And therefore measured in N in accordance with Din ISO 2439.

<b>Frame</b>	
Pad material:	S2 235 JR / S3 55 M2
Coating:	Galvanisation
Corrosion protection:	Galvanisation



The seat pad and backrest pad are moulded foam parts and are therefore not measurable in volumetric weight. Moulded parts are measured in accordance with DIN standards. Measurement is made in N.

## 20.2 Spare parts

\*\* When travelling on steep slopes, please do not travel at maximum speed or use the seat height adjustment, tilt or seat length adjustment functions and please exercise particular caution when travelling on uneven surfaces (e.g. grass, gravel, sand, ice and snow)!



See section "3 Safety notes"



Replacing original parts with non-original parts or parts made in the style of the original (copied) is strictly prohibited/forbidden! Only obtain your replacement parts from your dealer or PARAVAN GmbH.



## WARNING

**Danger of injury** for persons operating a PR 40 which does not correspond to the original or delivered condition.

**Material damage** to the PR 40 through the use of unapproved parts or incorrectly installed parts.

- > Do not make any technical modifications to the power wheelchair.
- > Only operate the PR 40 in its original or delivered condition.
- > Use only original and approved replacement parts.



## 21. **Electromagnetic compatibility (EMC)**

### 21.1 **Information regarding electromagnetic compatibility**

- ➔ The installation and maintenance of the device may only be carried out by specialist staff.
- ➔ Only the charging station supplied by the manufacturer may be used.
- ➔ The connector must be securely installed. Electronic components and cables must not be damaged.
- ➔ The use of longer cables lengths can result in increased emitted interference or reduced interference immunity.
- ➔ Only the original accessories supplied by the manufacturer may be used.
- ➔ In special cases, e.g. if highly sensitive equipment is being used in the direct vicinity of the device, additional remedial action might need to be taken so that the electromagnetic interference emission is further lowered below the set limit values.

## 21.2 Compliance level

The interference immunity levels in accordance with IEC 60601 are fulfilled.

### Manufacturer's declaration – electromagnetic interference

The PR 40 is designed to be operated under the electromagnetic conditions specified below. The customer or the user of the device should ensure that it is used under these conditions.

Emission measurements	Compliance	Electromagnetic conditions – guidelines
HF emissions in accordance with CISPR11	Group 1	The PR 40 only uses HF energy for its internal functions. Therefore its HF emissions are very low, and it is unlikely that adjacent electronic devices will be disturbed by these.
HF emissions in accordance with CISPR11	Class B	The device is designed to be used in all set-ups including living areas and those which are directly connected to a public power grid that also supplies power to buildings being used for living purposes.
Emission of harmonics in accordance with IEC61000-3-2	Class A	
Emission of voltage fluctuations/flickers in accordance with IEC61000-3-3	fulfilled	

Table 201 in accordance with DIN EN 60601-1-2, 6.8.3.201

## Manufacturer's declaration – electromagnetic immunity

The PR 40 is designed to be operated under the electromagnetic conditions specified below. The customer or the user of the device should ensure that it is used under these conditions.

Interference immunity tests	IEC 60601 – test level	Compliance level	Electromagnetic conditions – guidelines
Electrostatic discharge (ESD), in accordance with IEC 61000-4-2	± 6 kV Contact discharge ± 8 kV Air discharge	± 6 kV Contact discharge ± 8 kV Air discharge	Floors should be made from wood or concrete, or have ceramic tiles. If the flooring is made from synthetic material, the relative humidity must be at least 30%.
Fast transient electric bursts in accordance with IEC 61000-4-4	± 2 kV for power supply cables ± 1 kV for input and output cables	± 1 kV for input and output cables	The quality of the supply voltage should correspond to that of a typical business or hospital environment.
Surges, in accordance with IEC 6100-4-5	± 1 kV differential mode voltage ± 2 kV common-mode voltage	Not usable	The quality of the supply voltage should correspond to that of a typical business or hospital environment.

Voltage dips, short interruptions and fluctuations in the supply voltage, in accordance with IEC 61000-4-11	< 5% UT (>95% dip of UT) for 0.5 periods 40% UT (60% dip of UT) for 5 periods 70% UT (30% dip of UT) for 25 periods < 5% UT (>95% dip of UT) for 5 seconds	Not usable	The quality of the supply voltage should correspond to that of a typical business or hospital environment. If the movanimo user requires continued functionality in the event the power supply is interrupted, it is recommended that the movanimo be connected to an interruption-free power supply or a battery.
Magnetic field in the power supply frequency (50/60 Hz) in accordance with IEC 61000-4-8	3 A/m	3 A/m	Magnetic fields in the mains frequency should correspond to the typical values which are present in a business and hospital environment.
NOTE UT is the mains voltage before using the test level			

Table 202, in accordance with DIN EN 60601-1-2, 6.8.3.201

### 22.1 Handling of sealed storage batteries

When charging sealed storage batteries by water electrolysis at the positive electrode, the oxygen released is guided through a glass mat from the positive to the negative electrode and converted back to water again after a series of chemical reactions. During charging, part of the oxygen also enters the shared gas compartment. The housing of sealed storage batteries is designed to act as a pressure vessel through which reinforced walls prevent the excess oxygen from escaping until complete recombination at the negative electrode occurs. If improper charging is carried out, hydrogen along with oxygen also arises at the negative electrode. This hydrogen cannot be converted to water, but rather discharges including the oxygen present in the gas compartment via the safety valves after the permitted excess pressure level has been exceeded. If improper charging is avoided, no water loss will occur in sealed storage batteries and the storage batteries are completely maintenance-free. During storage and energy extraction there is no oxygen in the gas compartment and the storage battery has low pressure. Opening the valves must be avoided in all cases as if oxygen enters them, the negative electrode will be oxidised. This will result in irreparable damage and could lead to the complete power failure of the storage battery.

## 22.2 *Customer service booklet*

General

> 1. Inspection (12 months after commissioning)  
Date: Signature: Stamp:

Information

> 2. Inspection (annual)  
Date: Signature: Stamp:

Prepare

> 3. Inspection (annual)  
Date: Signature: Stamp:

Operate

> 4. Inspection (annual)  
Date: Signature: Stamp:

> 5. Inspection (annual)  
Date: Signature: Stamp:

Help

> 6. Inspection (annual)  
Date: Signature: Stamp:

Technology

> 7. Inspection (annual)  
Date: Signature: Stamp:

## 22.3 EC declaration of conformity





PARAVAN GmbH  
 Paraven Straße 5-10  
 72539 Pforzstätten-Aichelau  
 Deutschland  
 Telefon +49 (0) 73 88 / 99 95-66  
 Fax +49 (0) 73 88 / 99 95-7  
 Email: info@paravan.de

**MOBILITÄT FÜR DEN LEBEN**

**EG-Konformitätserklärung**  
 Declaration of Conformity

Gemäß Anhang VII der Richtlinie 93/42/EWG für Medizinprodukte  
 According annex VII of the council directive 93/42/EEC

Wir, die Firma  
 We, the company

PARAVAN GmbH  
 Paraven Straße 5-10  
 72539 Pforzstätten - Aichelau, Deutschland (Germany)

erklären als Hersteller hiermit in Alleinverantwortlichkeit, dass die Produkte der Klasse I  
 hereby declare on our own responsibility, that the class I medical devices

**Elektrolaststuhl / electrically powered wheelchair**  
**PARAVAN Rollstuhl - PR 40**

(Modelle gemäß Produktbeschreibung in der Technischen Dokumentation -  
 products according product description in our technical documentation)

In Einklang mit der Technischen Dokumentation hergestellt, werden und die grundlegenden  
 Anforderungen der Richtlinie 93/42/EWG Anhang 1 (EG-Richtlinie für Medizinprodukte)  
 erfüllen. Die Produkte sind mit dem CE-Zeichen gemäß oben genannter Richtlinie versehen.  
 are manufactured in accordance with the technical documentation and comply with the  
 Essential Requirements of Medical Devices Directive 93/42/EEC (annex 1). The products are labelled  
 the CE-Mark according to the above Directive.

*Aichelau 10.05.2019*

OT, Datum  
 Location, date

PARAVAN GmbH  
 Paraven-Straße 5-10  
 72539 Pforzstätten-Aichelau  
 Tel: +49 73 88 9995 611 Fax: 9995 999

*S.S.*  
 Siegfried, Unterschrift  
 Stamp, signature

Geschäftsführer: Roland Arnold  
 Amtsgericht Stuttgart HRB 370985  
 Umsatzsteuer-ID: DE237524279  
 IR 30681201

Kreisparkasse Reutlingen - IBAN: DE68 6405 0000 0100 0048 10 - BIC: SOLA DE33 REU  
 Volksbank Mönningen - IBAN: DE30 6409 3300 0042 7430 10 - BIC: GENO DE33 MÜN  
 Commerzbank AG Reutlingen - IBAN: DE27 6404 0033 0429 0229 00 - BIC: COBA DE33 640

[www.paravan.de](http://www.paravan.de)

Fig. 100: EC declaration of conformity

## 22.4 *Log of instructions provided upon delivery*

Due to the flexible setting options of the PR 40, the following information should be noted:

### **When using the tilt function:**

- It must be ensured that the seat is not tilted too far forwards or backwards, as otherwise you could slip out of the seat.
- The tilt function is set to your weight.
- Tilt the wheelchair first, then set the backrest.
- Always wear the seatbelt when using the tilt function.
- When using the tilt function, only half the speed of the selected movement level is possible.

### **Seat / backrest in the special orthopaedic seat**

- The backrest must only be adjusted as far as is necessary, as the motor is not powerful enough to lift the weight of the driver. Use the tilt function first.
- When adjusting the backrest and the tilting angle, be aware of attachments (rucksack, etc.).



A series of ten horizontal dashed lines spanning the width of the page, intended for handwriting practice.

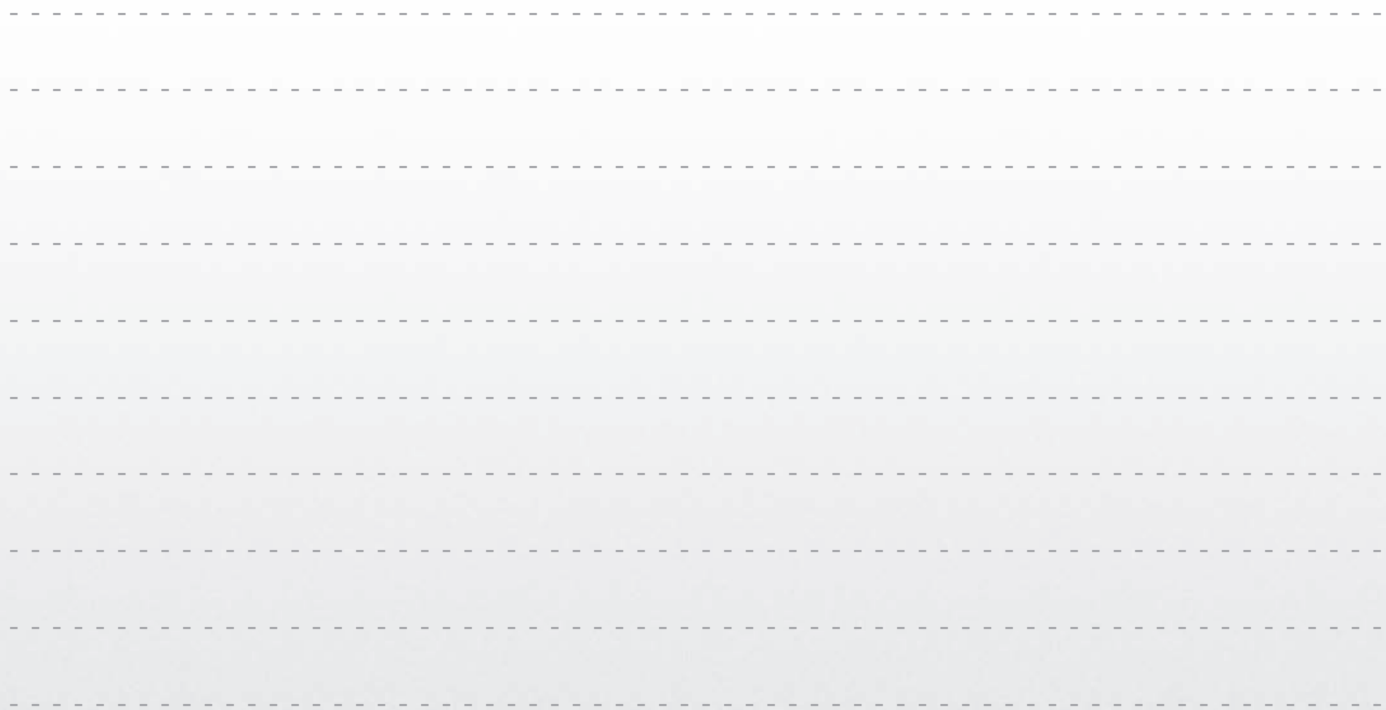



# PARAVAN®

PARAVAN WHEELCHAIR SERIES

## *User manual* **PR 40**

ORIGINAL INSTRUCTION MANUAL



 **EN** V1.4

### **Paravan GmbH**

Paravanstraße 5-10  
72539 Pfronstetten-Aichelau  
Germany

Phone: +49 (0) 73 88 / 99 95-60  
Fax: +49 (0) 73 88 / 99 95-999  
Email: [info@paravan.de](mailto:info@paravan.de)

[www.paravan.com](http://www.paravan.com)