

PRODUKTKATALOG

DANSK

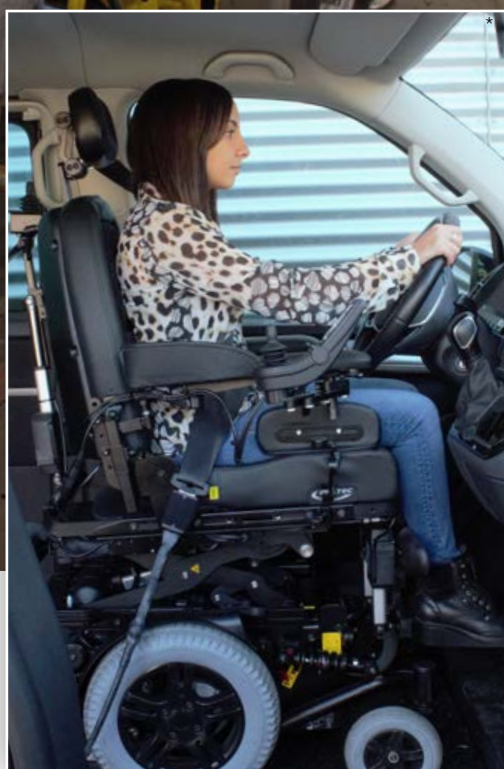

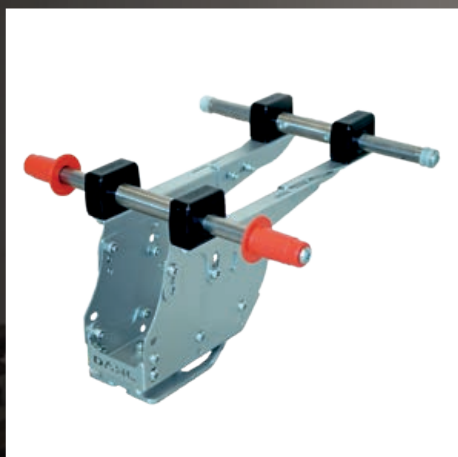

Dahl Engineering	
Om Dahl Engineering.....	4
Sikkerhed	5
Docking Systemer	6
Testede kørestole og adaptionssæt	7
Dahl MADSTM	10
Dahl VarioDockTM	11
Indretningseksempler til forankring af sæder – Dahl VarioDockTM	14
Køretøjsliste – godkendte monteringsæt til Docking Systemer.....	18
Dahl VarioDockTM - Godkendte monteringsæt KUN til kørestole	20
Dahl Docking Station MK II	30
Tilbehør	32
Dahl Docking Station MK II - Godkendte monteringsæt	34
Værktøj til montering af seleforankringsæt.....	44
Bilsæder	46
Dahl COMFORT Seat	47
Dahl COMFORT Seat - Godkendte monteringsæt.....	48
Gulvskinner og forstærkninger	49
Dahl HYBRID Seat	50
Tilbehør.....	53
Dahl Low Floor System	54
4-punkt WTORS	57
Køretøjsliste - Godkendte monteringsæt til 4 -punkt WTORS	60
Godkendte Monteringsæt til 4-punkt WTORS	63
- CLASSIC LINE	63
- EVOLUTION LINE	69
- HEAVY DUTY LINE 170kg	79
- HEAVY DUTY LINE 200kg	83
Reservedele: Sikkerhedsudstyr til kørestolsbrugere	88
ØVRIGE	
Afdækning til selelås.....	91
Specialunderstel til originale passagersæder	92
Fastspændingsudstyr til godssikring	93
Adaptore og tilbehør til godssikring	94
Salgs- og leveringsbetingelser.....	95

Om Dahl Engineering



Dahl Engineering er grundlagt af Claus Dahl Pedersen, der har mere end 30 års erfaring med at drive selvstændig, professionel virksomhed indenfor udvikling, sikkerhedstest og produktion af sæder og sikkerhedsudstyr til automobilbranchen. Dahl Engineering er karakteriseret ved at være en højtspecialiseret virksomhed, der tilbyder faglig, professionel viden inden for en række specialprodukter og udstyr til handicapkøretøjer, personbiler, varebiler, busser, racerbiler, ambulancer, politibiler, militærkøretøjer samt hjælpemidler til handicappede.

Dahl Engineering opførte i 2005 en fabriksbygning på 900 m², der rummer Danmarks eneste testanlæg til dynamiske afprøvninger (crash tests), et hydraulisk trækprøvningsanlæg samt prototypeværksted og lokaler til produktion, forskning og produktudvikling. I 2006, 2011 og igen i 2018 blev fabriksbygningen udvidet, så virksomheden har godt 2.100 m² under tag. Dahl Engineering er anerkendt af Færdselsstyrelsen som prøvningslaboratorium i Danmark. Certificeringstests i henhold til EU-direktiver og internationale sikkerhedsstandarder på området, overvåget af det akkrediterede prøvningsinstitut TÜV Rheinland, kan også foretages på virksomhedens testanlæg.

Nye fokusområder for sikkerhed

Udviklingen indenfor automobil sikkerhed står aldrig stille, og nye temaer dukker hele tiden op. Mange kørestole og hjælpemidler er i dag ikke konstrueret at kunne modstå belastningen ved et trafikuheld. En surrogatkørestol med en vægt på 85 kg er tilstrækkelig til at få en docking station godkendt i henhold til ISO 10542-1. Det synes vi er utilstrækkeligt, når mange elektriske kørestole nemt kan veje op til 180-190kg plus bruger. For kørestolsbrugere, der transporteres i bil, betyder det en væsentlig sikkerhedsrisiko. Derfor tester vi vores Docking System med en surrogatkørestol som vejer 200kg.

Med vedtagelse af et EU-direktiv (2007/46) og EU-forordning 2018/858, Bilag II, Del III, Tillæg 3, der omhandler procedurer for test og godkendelse af fastspændingsudstyr og sikkerhedsseler til kørestolsbrugere i biler er der kommet øget fokus på sikkerheden, når kørestole anvendes som et sæde i køretøjer. Det har bl.a. bevirket, at der i kørestolslicitationer stilles krav om, at kørestol og fastspændingsystem skal crash testes sammen og leve op til ISO 7176-19.

EU's Medicindirektiv foreskriver, at en kørestols CE-mærkning ugyldiggøres og skal fjernes, såfremt der foretages en væsentlig ændring af det godkendte, såsom montering af et docking system, som ikke er blevet testet og CE-godkendt sammen med den pågældende kørestol. Endvidere fremgår det, at den der monterer eller tilpasser ikke godkendt udstyr eller monterer systemet på en måde, som falder uden for kørestolsfabrikantens specifikationer, betragtes som ansvarlig fabrikant og har ansvaret for udstyrets kvalitet, sikkerhed, ydeevne og ny dokumentation. For at undgå at CE-godkendelsen bortfalder, skal kørestol og docking system være testet og CE-godkendt sammen og instruktioner for montering og anvendelse sammen med det godkendte docking system, skal være beskrevet i kørestolsfabrikantens manual. På hjemmesiden www.dahlengineering.dk kan man se alle kørestole, der er blevet testet og godkendt sammen med Dahl's Docking model Mk. II og VarioDock. Som dokumentation kan en manual med CE-konformitetserklæring og vejledning for montering af docking systemet på hver enkelt model downloades. Klik på: Produkter – Dahl Docking Systemer - Godkendte kørestole og manualer.

Dahl Engineering har med over 30 års erfaring inden for udvikling, sikkerhedstest og produktion af automobiludstyr en omfattende viden om sikkerheden og lovkravene.

Som underleverandør af komponenter kan vi også tilbyde et tæt samarbejde omkring udvikling og test/godkendelse af komponenterne i den helhed, hvori de skal anvendes.

Dahl Engineering har specialiseret sig i at levere godkendt udstyr, der er testet således internationale sikkerhedsstandarder og EU-sikkerhedskrav i biler opfyldes. Og dette uanset om produkterne skal anvendes til handicappede eller ikke-handicappede - når dette er muligt - hjælpemidlets konstruktion og funktion taget i betragtning.



Docking Station

Sikkerhedsstandarderne for fastspændingsudstyr til kørestole er endnu ikke på højde med sikkerhedskravene for udstyr til biler i øvrigt. Fastspændingsudstyr skal, ifølge den nuværende ISO-standard, kun være i stand til at kunne modstå belastningen fra en kørestol med en vægt på 85 kg.

Hos Dahl Engineering mener vi, at kravene er for dårlige og har derfor udviklet det sikreste og mest gennemtestede system på markedet. Dahl's Docking Station leveres med det mest omfattende dokumentationsmateriale på markedet, og er som det første system testet og TÜV godkendt i et stort antal køretøjer til fastspænding af kørestole med en vægt på 200 kg + bruger. Vi tilbyder over 55 køretøjsspecifikke monterings sæt.

Dahl Engineering har specialiseret sig i at kunne tilbyde fastspændingsudstyr til kørestolsbrugere, der opfylder de skrappe EU M1 sikkerhedskrav for personbiler i henhold til ECE-regulativerne 14 og 17 (Om sæders og sikkerhedssellers forankring i motorkøretøjer), når det er muligt - hjælpemidlets konstruktion og funktion taget i betragtning. I skrivende stund har vi også testet Mercedes Sprinter 907/910, Freightliner Sprinter, samt VW Crafter (-2016) i henhold til FMVSS/CMVSS 207/210.

4-punkt WTORS

Der er udført mere end 150 tests af Dahl's 4-punkt kørestolsfastspændinger i køretøjer i henhold til EU-forordning 2018/858 annex II, del III, tillæg 3, samt ISO 10542-1:2012 og 7176-19:2008. På grundlag af de mange tests har vi opnået TÜV godkendelse på mere end 100 køretøjsspecifikke monterings sæt fra 85 kg til 200 kg. Dermed er Dahl Engineering's 4-punkt kørestolsfastspændinger på forkant med de seneste EU-sikkerhedskrav vedr. sikring af kørestolsbrugere i køretøjer.

Ombygning af biler

Vi tilbyder køretøjsombyggere at samarbejde omkring tests hvori Dahl Engineering's produkter indgår, så den samlede ombygning lever op til gældende krav. Vi kan udføre udmattelsestests af karosseriet i henhold til TÜV Merkblatt 751. Ved testen afprøves langtidsholdbarheden af det ombyggede køretøj, for at sikre sig mod at karosseriets bærende dele skal revne eller bryde sammen efter års brug. Karosseriet med ombygningen kan blive udsat for 150.000 prøvningscyklusser. På grundlag af de udførte tests kan bilombyggere søge om accept af køretøjets ombygning fra bilproducenterne for at opnå såkaldte "Unbedenklichkeitsbescheinigung".



ECE regulativ 17
H-punkt måling



ECE regulativ 14



Dahl Engineering sætter endnu engang nye standarder for fleksibilitet og sikkerhed!

Vi glæder os til at fremover kunne tilbyde to forskellige Docking stationer, som passer til et utal af kørselsbehov. Næsten alle kørestole, som vi har testet med vores Dahl Docking Station MK II, er kompatibel med Dahl VarioDock™.



Dahl VarioDock™

Vores elektrisk højdejusterbar Docking Station, muliggør fastspænding af kørestole med forskellige frihøjder og sæder med en integreret 3-punkt sele.

- Opfylder ISO 10542-1, ISO 7176-19 samt de strenge testkrav i henhold til ECE-regulativ 14 og 17 vedr. test af sæder og seleforankringer i køretøj kategori M1.
- Motoriseret højdejustering (fra 61-91 mm).
- Testet for kørestole med en vægt på op til 200 kg plus bruger.
- Godkendt til fastgørelse af Dahl COMFORT Seat
- Crash testet og CE-mærket med ca. 150+ kørestolsmodeller

Dahl Docking Station MK II

er vores anden generations Docking Station, som muliggør fastspænding af kørestole fra mange forskellige kørestolsproducenter.

- Opfylder ISO 10542-1, ISO 7176-19 samt de strenge testkrav i henhold til ECE-regulativ 14 og 17 vedr. test af sæder og seleforankringer i køretøj kategori M1.
- Højdejustering ved brug af afstandsplader
- Testet for kørestole med en vægt på op til 200 kg plus bruger
- Crash testet og CE-mærket med ca. 150+ kørestolsmodeller



Adaptionssæt til kørestolen

Godkendte kørestole med Dahls docking systemer

I henhold til EU's medicindirektiv klassificeres en kørestol som medicinsk udstyr klasse 1, og skal CE-mærkes og godkendes som sådan. Den der monterer eller tilpasser ikke godkendt udstyr eller monterer systemet på en måde, som falder uden for kørestolsfabrikantens specifikationer, bryder CE-godkendelsen og betragtes som ansvarlig fabrikant og har ansvaret for udstyrets kvalitet, sikkerhed, ydeevne og teknisk dokumentation jævnfør krav i forordning om medicinsk udstyr.

Monteres vore docking systemer på en kørestol, som er blevet testet og godkendt af kørestolsproducenten, forbliver dennes CE-godkendelse intakt. Det er dog en betingelse, at anvisningerne i kørestolsproducentens manual følges nøje.

Vores nye docking adaptionssystem til manuelle kørestole, Dahl MADS™, (Multi Adjustable Docking System) har netop bestået test i henhold til ISO 7176-19:2022 med følgende kørestole: ETAC Cross 6, R82 Kudu.

I skrivende stund er kørestolsproducentens dokumentation inklusive bruger- og monteringsvejledning under udarbejdelse, og adaptionssæt er derfor endnu ikke til salg. Så snart dokumentationen og MADS-sættene vil være tilgængelige til salg, kan varenr., crash-test video og bruger- og monteringsvejledning som sædvanligt findes på vores hjemmeside.

Videoser af crash-tests, samt kørestolsproducenternes bruger og servicemanualer findes på vores hjemmeside.

Kontakt venligst kørestolsproducenten vedr. godkendt udstyr og frihøjde for at sikre kompatibilitet med vores Dahl Docking Systemer.

KØRESTOL Mærke og model	Kørestolen er seriemæssig forberedt til montering af docking låseplade	Eftermonterbar adaptionssæt kan bestilles hos Dahl Engineering	Eftermonterbar adaptionssæt kan bestilles hos kørestolsproducenten	Adaptionssæt kan IKKE eftermonteres. Er kun tilgængelig som option fra kørestolsproducenten, når stolen bestilles.	Kompatibel med VarioDock
Alu Rehab Netti Mobile D1		#501822			✓
Baldertech F380 (280) Finesse tiltstol			Balder#HP20071413		✓
Baldertech F390 (290) Finesse ståstol			Balder#HP20071413		✓
Baldertech J335 (235) Junior tiltstol			Balder#HP20071413		✓
Baldertech J340 (240) Junior ståstol			Balder#HP20071413		✓
Baldertech Liberty RWD			Balder#HP20071413		✓
Degonda T4 2x2		#503213			✓
Degonda T4 Compact		#503213			✓
Dietz Power Sango Advanced FWD SEGO			Dietz#5001168		✓
Dietz Power Sango Advanced MWD SEGO			Dietz#5001168		✓
Dietz Power Sango Advanced RWD SEGO			Dietz#5001168		✓
Dietz Power Sango Slimline FWD SEGO			Dietz#5001169		✓
Dietz Power Sango Slimline MWD SEGO			Dietz#5001169		✓
Dietz Power Sango Slimline RWD SEGO			Dietz#5001169		✓
Glide CentroGlide		#502237			✓
Invacare AVIVA RX				Invacare #SP1653422	✓
Invacare FDx					✓
Invacare Storm4				#ATZ1450	✓
Invacare Storm4 Xplore				#ATF1450	✓
Invacare TDX SP2 (WB)				#SP1564843	✓
Invacare TDX SP2 (NB)				#SP1564807	✗
Invacare TDX SP2 MBL Tilt-Lifter (WB)				#SP1564843	✓
Invacare TDX SP2 MBL Tilt-Lifter (NB)				#SP1564807	✗
Karma Leon FWD Kameleon			Karma#19170000061		✓
Karma Leon FWD Versus			Karma#19170000061		✓
Karma EVO Altus / Lectus-LR		#503194			✓

Adaptionssæt til kørestolen

KØRESTOL Mærke og model	Kørestolen er seriemæssig forberedt til montering af docking låseplade	Eftermonterbar adaptionssæt kan bestilles hos Dahl Engineering	Eftermonterbar adaptionssæt kan bestilles hos kørestolsproducenten	Adaptionssæt kan IKKE eftermonteres. Er kun tilgængelig som option fra kørestolsproducenten, når stolen bestilles.	Kompati- bel med VarioDock
Karma Leon RWD			Karma#15120000023		✓
Karma Mid Lectus		#503339			✓
Karma Morgan			Karma#4020169		✓
Karma Morgan Sling		#503339			✓
Karma Morgan M Versus		#503339			✓
LEVO LCM 2		#502322			✓
Magic Mobility 360		#501798			✓
Medema MC 1122	✓				✓
Medema MC 1124 Adult		#502378			✓
Medema MC 1124 Child		#502378			✓
Medema MC 1144 Adult		#503236			✓
Medema MC 1144 Child		#503236			✓
Meyra iChair MC2 1.611		#501909			✓
Meyra iChair MC2 1.611 / Electrical backrest		#503453			✓
Meyra iChair MC3 1.612			Meyra#1079816		✓
Meyra iChair McFront 1.613		#501619			✓
Meyra iChair McFront 1.613 / Electrical backrest		#501620			✓
Meyra iChair Orbit 1.618		#503657			✓
Meyra iChair Meylife 1.650		#503657			✓
Neatech Dyna S304		#501905			✓
Neatech EVO 1		#503340			✓
Neatech EVO 3		#502210			✓
New Live Magix			NewLive MA.O.P.01. AC.Z.800003		✓
New Live Magix II	✓*				✓
NHD LS 300		#503341			✓
NHD LS300/45		#503341			✓
Otto Bock Juvo B4 RWD		#503184			✓
Otto Bock Juvo B5/B6 FWD		#503261			✓
Otto Bock Juvo B5/B6 MWD		#503261			✓
Otto Bock Juvo B5/B6 RWD		#503261			✓
Paravan Heavy Duty			Paravan#33187		✓
Paravan PR 25		#502064			✓
Paravan PR 40		#502064			✓
Paravan PR 50			Paravan#33187		✓
Paravan Piccolino			Paravan#33187		✓
Roltec Boa 2		#503342			✓
Quantum Rehab (Pride Mobility), Q6 Edge 2.0*		#502378			✓
Quantum Rehab (Pride Mobility), Q6 Edge 3.0*		#502378			✓
Roltec Moveo		#501819			✓
Roltec Viper			Roltec#70658		✓
Roltec CT4 RWD / Vision			Roltec#70658		✓
Scout Mobility X10 FWD		#503366			✓
Scout Mobility X10 MWD		#503366			✓
Scout Mobility X10 RWD		#503366			✓

* Venligst forhør dig hos Pride/Quantum salgsorganisationer for tilgængelighed i Canada og USA.

Adaptionssæt til kørestolen

KØRESTOL Mærke og model	Kørestolen er seriemæssig forberedt til montering af docking låseplade	Eftermonterbar adaptionssæt kan bestilles hos Dahl Engineering	Eftermonterbar adaptionssæt kan bestilles hos kørestolsproducenten	Adaptionssæt kan IKKE eftermonteres. Er kun tilgængelig som option fra kørestolsproducenten, når stolen bestilles.	Kompati- bel med VarioDock
SKS Swiss Viva Grand			SKS#22.0218		✓
SKS Swiss Viva Grand M		#503342			✓
Sunrise Medical Q100 R		#503259			✓
Sunrise Medical Q200 R		#503259			✓
Sunrise Medical Q300M Mini		#500094			✗
Sunrise Medical Q300 R		#503012			✓
Sunrise Medical Q400 F		#503637			✓
Sunrise Medical Q400 M		#503439			✓
Sunrise Medical Q400 R		#503637			✓
Sunrise Medical Q500 F		#503637			✓
Sunrise Medical Q500 H		# 501798			✓
Sunrise Medical Q500 M		#503439			✓
Sunrise Medical Q500 R		#503637			✓
Sunrise Medical Q700 F		#501889			✓
Sunrise Medical Q700 M		#503439			✓
Sunrise Medical Q700 R		#503637			✓
Sunrise Medical Q700 UP F		#501889			✓
Sunrise Medical Q700 UP M		#503439			✓
Sunrise Medical QUICKIE Salsa M2		#501798			✗
Sunrise Medical QUICKIE Salsa R2		#501756			✓
TA Service IQ RWD			TA #97189		✓
TA Service IQ FWD			TA #97189		✓
TA Service IQ MWD			TA #97189		✓
TA Service Indoor Wave			TA #95255		✓
Talart JT-Sparkle			JT01154		✓
Wolturnus A-Run				Wolturnus #20778	✓
Wolturnus Rex 350				Wolturnus #20779	✓
Wolturnus W5				Wolturnus #20776 or 20777	✓

Alle udgåede, men testede og godkendte kørestole, kan findes på vores hjemmeside.

Eksempler af testede kørestole med vores Dahl Docking Systemer

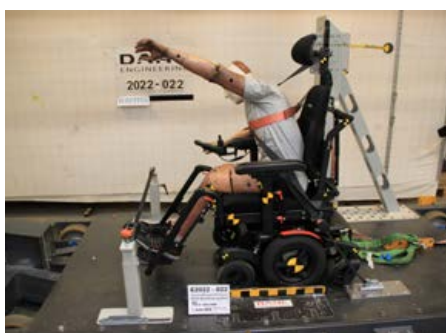

Dahl MADSTM (kort for **Multi Adjustable Docking System**) er vores nye patenterede quick-release kørestols adaptions system, som muliggør at fastramme såvel som foldbare manuelle kørestole kan sikres med vores docking stationer MKII og VarioDockSTM.

Dahl MADSTM består af en letvægts underramme, som er justérbar både i højde, hældning og længde. Den kan derudover nemt tilpasses kørestole med forskellige bredder. Standardrørene skæres til en passende længde for at kunne spille sammen med alle de andre justeringsoptioner der giver mulighed for en optimal siddeposition for brugeren af kørestolen.

Et beslag monteret på kørestolens ramme, samt et enkelt og effektivt låsesystem gør, at underrammen kan til- og frakobles uden brug af værktøj som også er et ufravigeligt krav når kørestolen skal foldes sammen.

I de forgangne år har vi modtaget flere og flere henvendelser ang. adaptions kits til manuelle kørestole. Henvendelserne kom fra private køretøjs ejere, plejehjem og skoler, såvel som offentlige og private transport

udbydere som ledte efter en mulighed for at erstatte de tidskrævende og arbejdsintensive 4-punkts kørestols sikringer som er meget udbredt til den dag i dag.

Dahl MADSTM kørestols adaptions kits er skræddersyet til hvert enkelt kørestolsmærke og model. Kørestole og adaptions kits bliver crash-testet samlet i henhold til ISO 7176-19:2022.

Hvis en specifik kørestol ikke allerede er på listen over godkendte stole, vil vi med glæde – sammen med kørestolens producent – udforske mulighederne om et adaptionskit kan udvikles til denne.

Producenterne af godkendte kørestole på det europæiske marked har derudover CE- mærket deres stole for brug sammen med Dahl MADSTM. Når Dahl MADS adaptionskittet er installeret efter anvisningerne i producentens brugermanual, kan en installatør stole på, at køretøjets garanti og kørestolens CE- mærkning er fortsat gældende.



MULTI JUSTERBAR • QUICK RELEASE



Dahl VarioDock™

Vores nye Dahl VarioDock™ er ikke bare den eneste elektrisk højdejusterbare docking system til kørestole, som muliggør fastspænding af kørestole med forskellige frihøjder og sæder med en integreret 3 punkt sele, men det er også det eneste system, der opfylder ISO 10542-1, ISO 7176-19 samt de strenge testkrav i henhold til ECE regulativ 14 og 17 vedr. test af sæder og seleforankringer i køretøj kategori M1.

Takket være Dahl VarioDock™ systemet, kan fastspænding af kørestolsbrugere og andre passagerer i et køretøj foretages med en hidtil uset lethed, hurtighed og sikkerhed. Dahl VarioDock™ docking system giver mere fleksibilitet og alsidighed end noget andet sædeforankringssystem, da indretningen af kørestole og sæder kan ændres meget hurtigt med en minimal arbejdsindsats og tidsforbrug. Et docking system forbedrer arbejdsmiljøet for chauffører, da disse ofte kæmper med meget lidt plads og dårlige arbejdsstillinger ved fastspænding med 4 punkt strop-systemer.

- Motoriseret højdejustering (fra 61-91 mm).
- Tidsforbrug – kun ¼ af fastspænding med et 4-punkt strop system.
- Testet for kørestole med en vægt på op til 200 kg plus bruger.
- Godkendt til fastgørelse af Dahl COMFORT Seat
- Motoriseret tilspænding i 4 trin for fjernelse af uønsket slør.
- Åbentid for låsemekanisme kan sættes til 5 eller 8 sekunder.
- Lampe i betjeningspanel for påkrævet service.
- Forbedrer arbejdsmiljøet for chauffører.
- Ingen stropper i vognbunden, som man kan snuble over.
- Crash testet og CE-mærket med ca. 150+ kørestolsmodeller



Patenteret



Dahl VarioDock™



Dahl VarioDock™ kan anvendes til at fastspænde manuelle og elektriske kørestole med en vægt på op til 200 kg plus bruger samt vores COMFORT Seat med integreret 3 punkt sele.

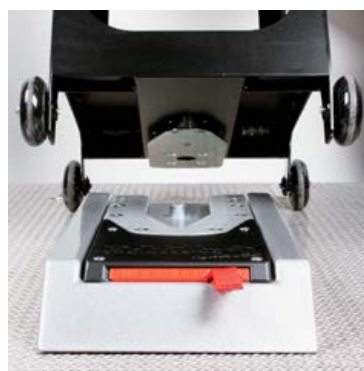

Indholdet af Dahl VarioDock™ basissæt art. nr. 503600



Forankring af Dahl COMFORT Seat med integreret 3-punkt sikkerhedssele

Dahl VarioDock™ er også blevet testet og godkendt til forankring af Dahl COMFORT Seat med integreret 3-punkt sikkerhedssele, med en placering på 2. sæderække og bagud, i et antal køretøjsmodeller.

Anvendelse af VarioDock™ til forankring af Dahl COMFORT Seat med integreret 3-punkt sikkerhedssele kræver et særlig kraftigt forankringssæt til vognbunden, som er konstrueret, testet og godkendt til det konkrete køretøj og monteringsposition.

I tilfælde af en kollision vil køretøjets vognbund blive udsat for en meget højere momentbelastning ved anvendelse af et sæde med integrerede seleforankringspunkter, end den f.eks. gør ved en kørestol, hvor alle seleforankringspunkter er forankret i køretøjets karosseri og vognbund.

Se venligst det aktuelle leveringsprogram over godkendte og køretøjsspecifikke forankringssæt i vores produktkatalog, som kan downloades på vores hjemmeside <http://wtors.com>

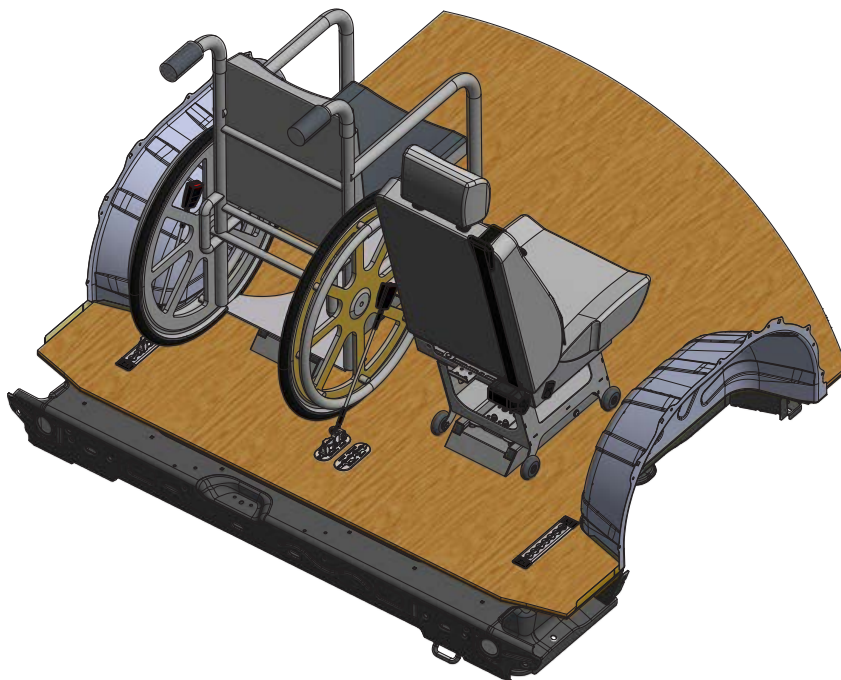

ADVARSEL! Fare for død eller alvorlige kvæstelser

Anvend ikke VarioDock™ til forankring af Dahl COMFORT Seat eller et andet sæde med integrerede seleforankringspunkter, såfremt køretøjet ikke har fået monteret et forankringssæt til VarioDock™, som er godkendt til dette.

Er der ikke blevet monteret et forankringssæt, som er godkendt til formålet, er der risiko for, at bruger og andre passagerer i køretøjet, kan pådrage sig alvorlige eller dødelige skader under en kollision, som følge af at vognbunden deformeres kraftigt, eller at forankringspunkterne til docking stationen rives løs.

Spørg derfor din forhandler, om der er blevet monteret et forankringssæt til VarioDock™, som er godkendt til forankring af Dahl COMFORT Seat, i det pågældende køretøj og monteringsposition, inden ibrugtagning.

Her vises nogle godkendte indretningseksempler baseret på vores COMFORT Seat og VarioDock™

Dahl VarioDock™ systemet giver mere fleksibilitet og alsidighed end noget andet fastspændingssystem på markedet, da dette som det eneste system både er godkendt til forankring af sæder og af kørestole. I køretøjer indrettet med VarioDock™ systemet, kan indretningen og sædekonfigurationen ændres hurtigere end med noget andet fastspændingssystem og dette kræver mindre arbejdsindsats og tidsforbrug end noget andet system.

Vi har valgt at vise et eksempel per køretøjsmodel, men der findes utallige muligheder.

Kontakt os gerne med henblik på at finde den indretning du har brug for.

Vær opmærksom på at kontrollere køretøjs kategorisering (M1, M2 eller M3), hjulafstand, udstyrsvarianter, original og eftermonteret udstyr f.eks. en lift, som er afgørende for om et køretøj er egnet til en given indretning, da dette påvirker køretøjets nyttelast, krav til afstand mellem sæder og kørestole, gangbredde samt adgang til nødudgang m.m.

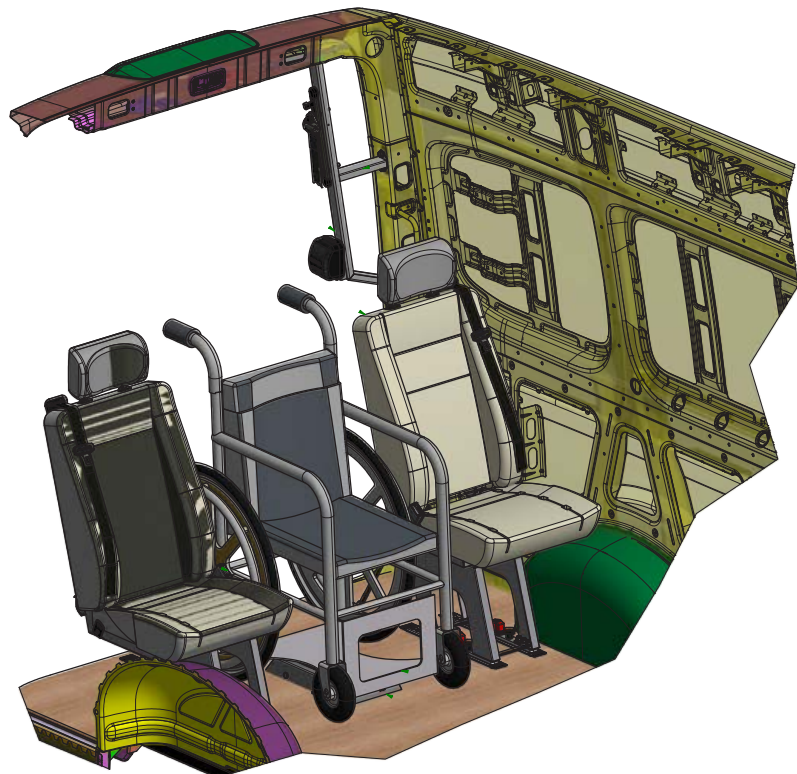

Kørestolen kan erstattes af Dahl Comfort Seat.

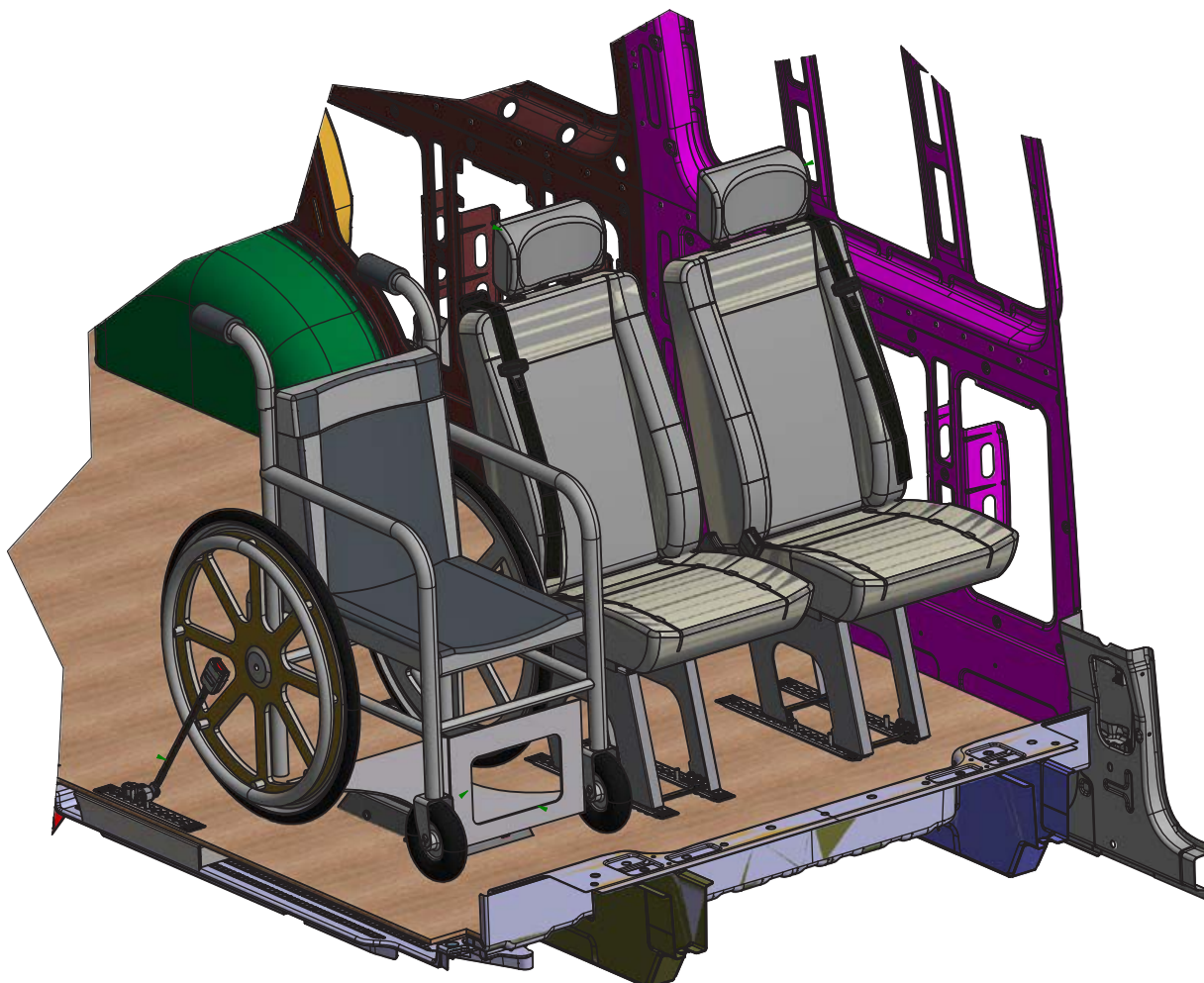

Dahl VarioDock System - indretningseksempler til forankring af sæder

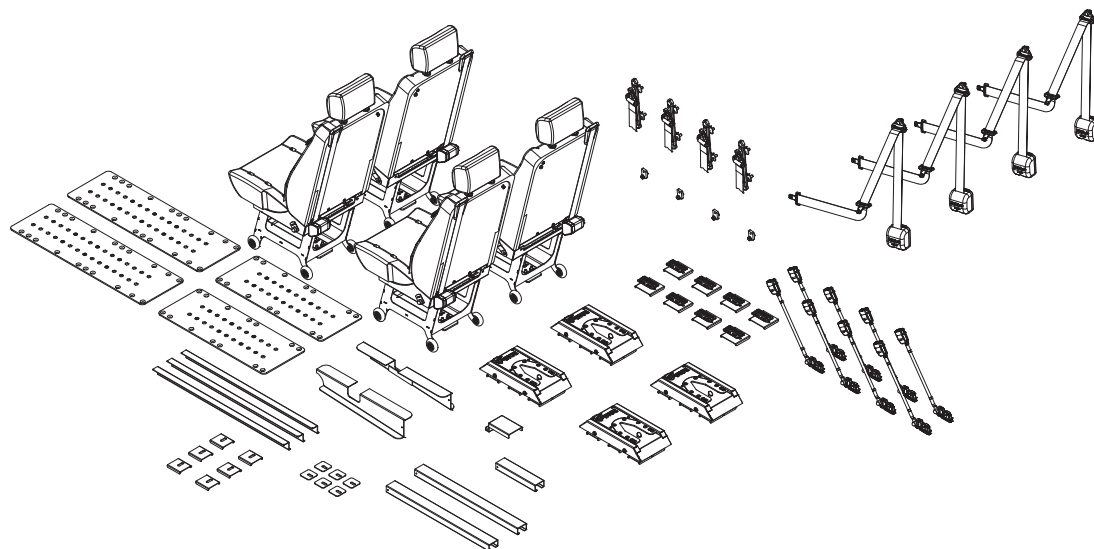

Art. nr. 503661

VW T5 & T6

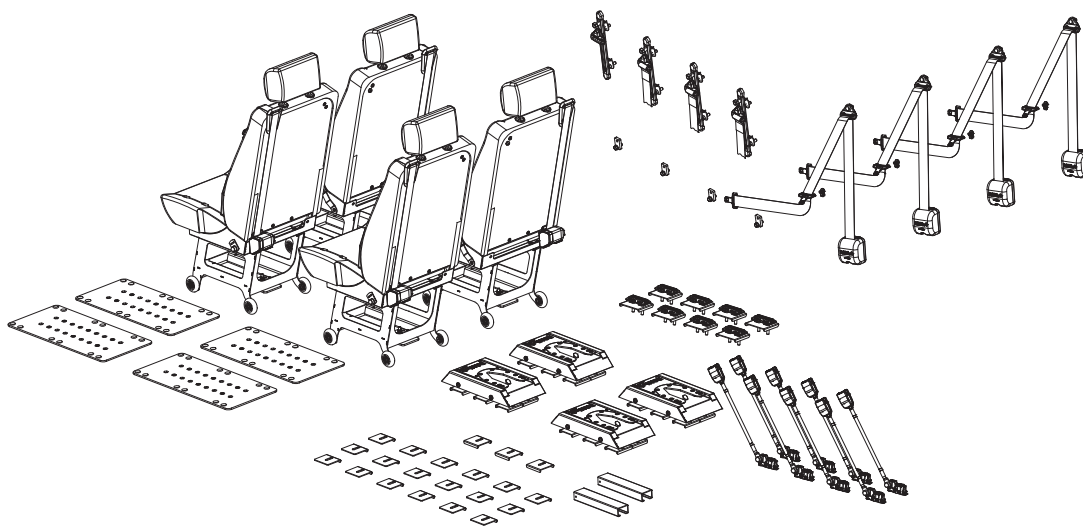
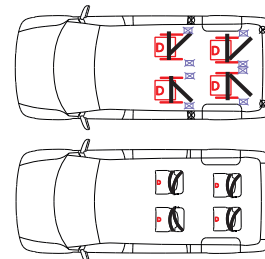

Art. nr. 503662

Mercedes Vito &
V-Class W447

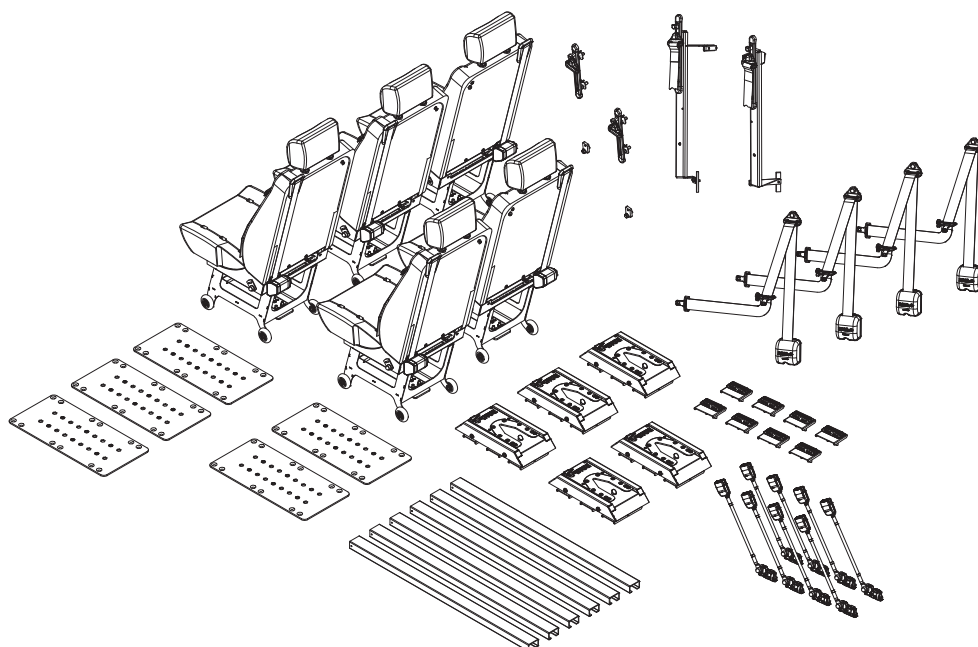
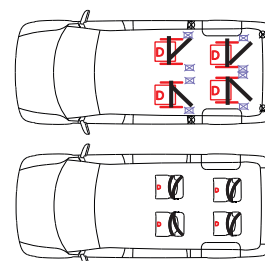

Art. nr. 503663

Citroën Jumper Y
Fiat Ducato X250
Peugeot Boxer Y

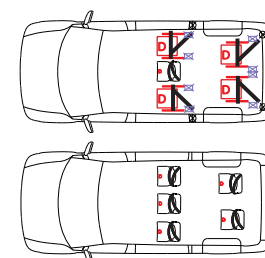

Dahl VarioDock System - indretningseksempler til forankring af sæder

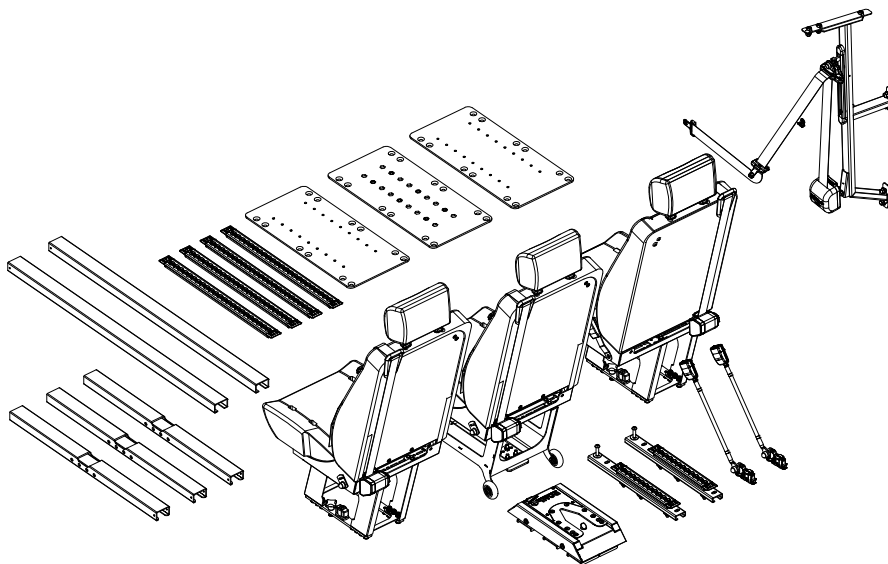

Art. nr. 503776

MB Sprinter 906, 907 & 910

VW Crafter -2017

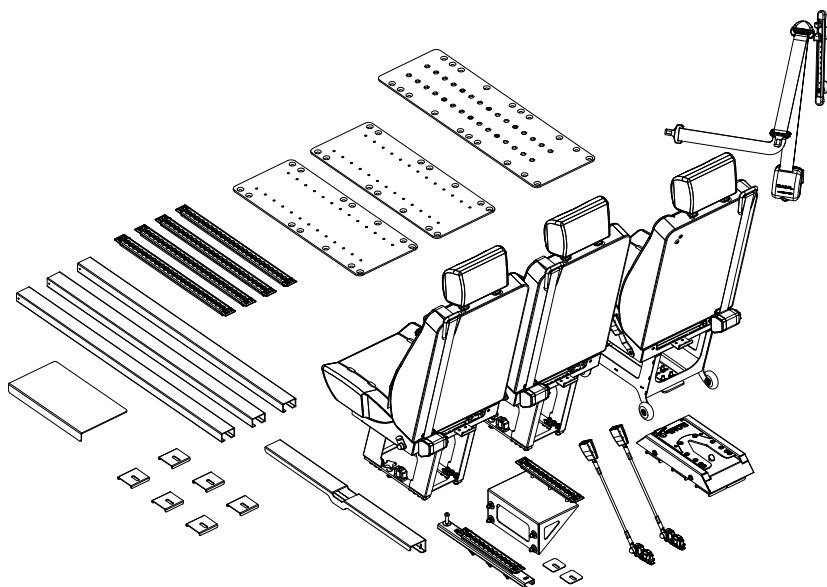
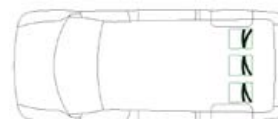

Art. nr. 503779

MB Sprinter 906, 907 & 910

VW Crafter -2017

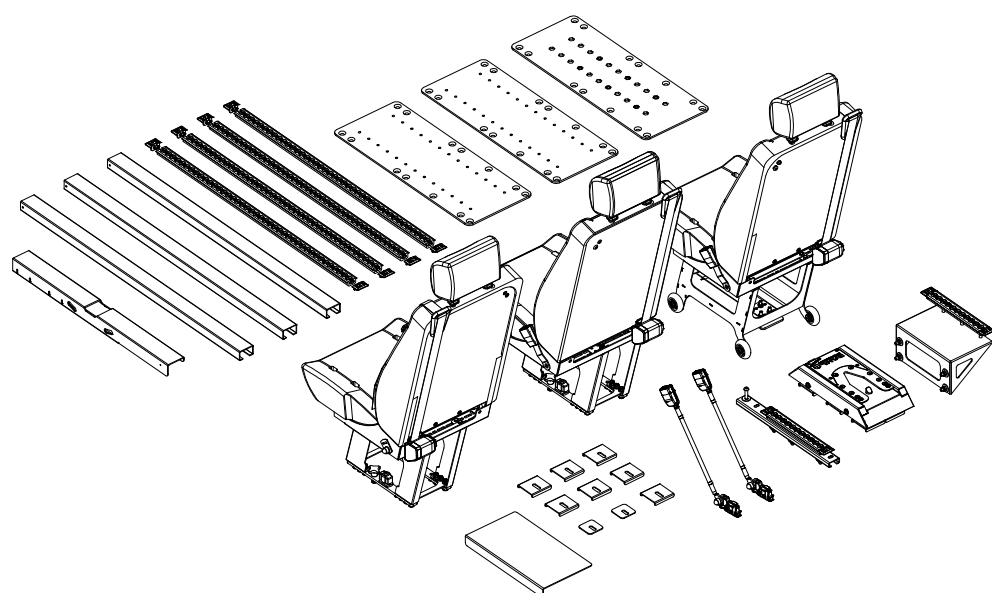
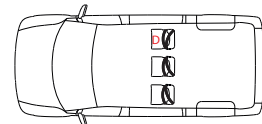
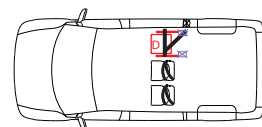

Art. nr. 501155

MB Sprinter 906, 907 & 910

VW Crafter -2017

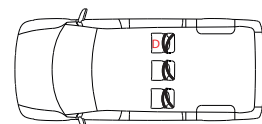
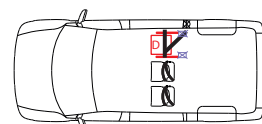

Dahl VarioDock System - indretningseksempler til forankring af sæder

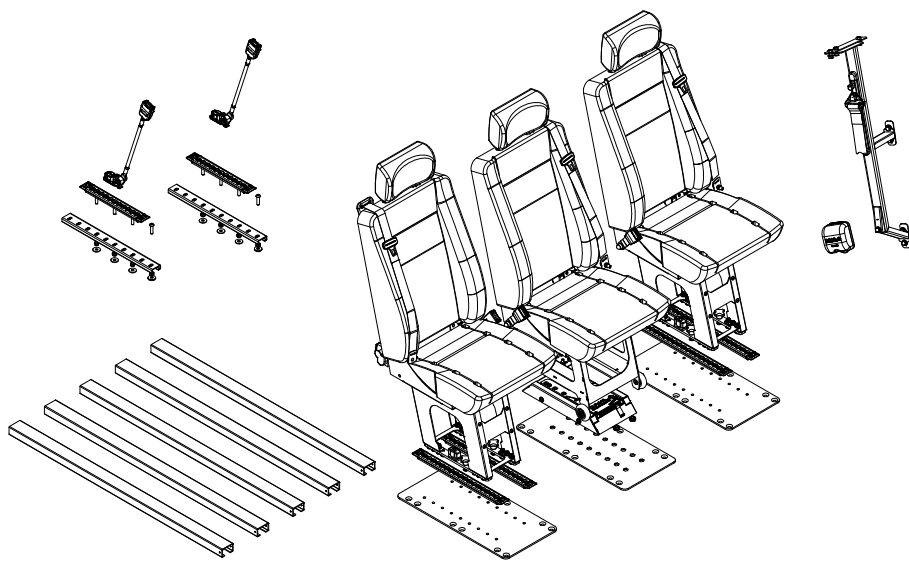

Art. nr. 501451

MAN TGE 2017-

VW Crafter -2017

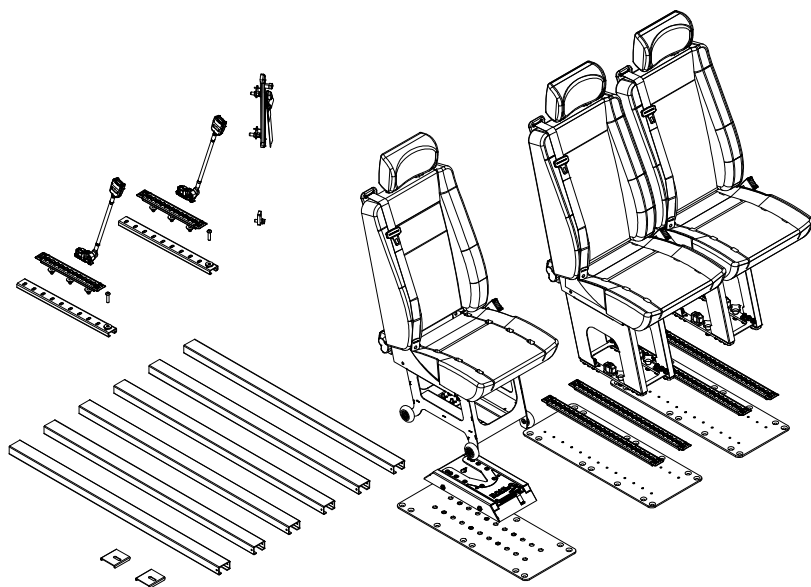
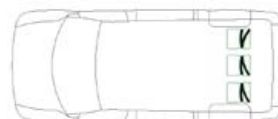

Art. nr. 501457

Nissan NV400

Opel Movano X62

Renault Master X62

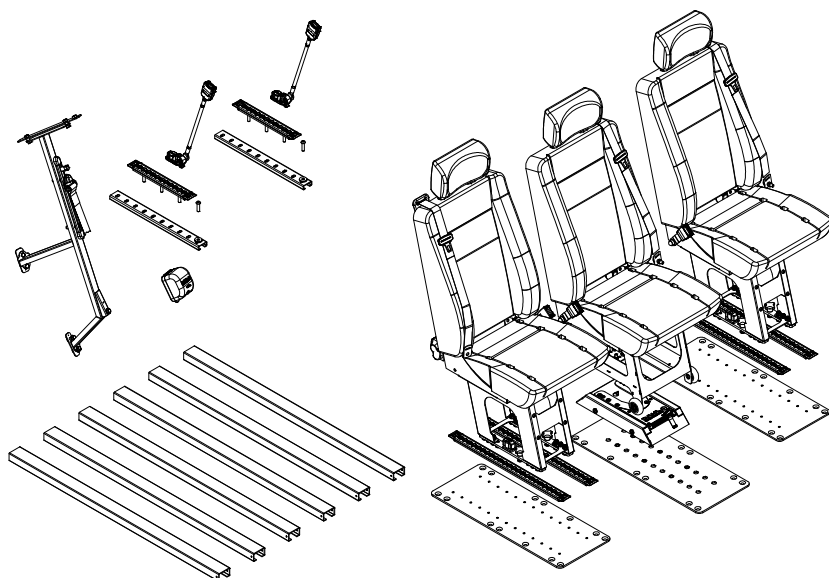
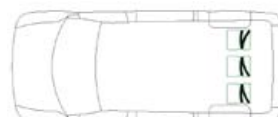

Art. nr. 501458

Nissan NV400

Opel Movano X62

Renault Master X62

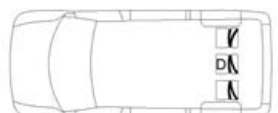
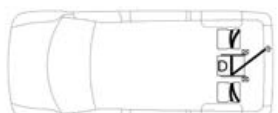

Køretøjsliste - godkendte monteringsæt til Dahl Docking Systemer - kun til kørestole

Bilmærke	Bilmodel	Position af skulderseleforankring	Gulvbeslag type	Til B-Stolpe			MK II	Vario	FMVSS 207/ CMVSS 207	FMVSS 210/ CMVSS 210	
				Antal dockinger	Sædeunderstel	Skulderseleforankring					
Citroën	Berlingo, Tripod/allied dropfloor conversion Jumper Y	B	/	2	1	1	503461	503954			
		C	surface				502171	503920			
		C	flush				502172	503921			
		W	surface				502179	503928			
		W	flush				502180	503929			
	Jumpy X	C	surface				502171	503920			
		C	flush				502172	503921			
		RD	surface				502177	503926			
		RD	flush				502178	503927			
	Jumpy & Spacetourer KO, Freedom Drop Floor Conversion	B			1	0	0	503303	503950		
		B			1	0	1	503304	503951		
		B			2	1	0	503305	503952		
		B			2	1	2	503306	503953		
		C (middle)	surface					503665			
Jumpy & Spacetourer KO	C	surface				503302	503949				
	C	flush				503301	503946				
Fiat	Doblo high roof SWB & LWB	D	surface				503121	503940			
		D	flush				503120	503939			
	Ducato X250	C	surface				502171	503920			
		C	flush				502172	503921			
		W	surface				502179	503928			
		W	flush				502180	503929			
	Scudo X270	C	surface				502171	503920			
		C	flush				502172	503921			
		RD	surface				502177	503926			
		RD	flush				502178	503927			
	Talento 2016-	C	surface				502171	503920			
		C	flush				502172	503921			
		D	surface				502171	503920			
		D	flush				502172	503921			
Ford	Transit Custom V362	C	surface				502171	503920			
		C	flush				502172	503921			
	RD	surface				502177	503926				
	RD	flush				502178	503927				
	C	surface				502194	503932				
Jeep MAN	Transit V363 Renegade, ACA Drop floor conversion TGE 2017-	B		2	1	0	501551	501552			
	C	surface				503142	503941				
	C	flush				503143	503942				
	W	surface				503145	503944				
	W	flush				503144	503943				
	D	surface				502171	503920				
	D	flush				502172	503921				
Mercedes	Vito & V-Class W447	B		2	1	2	502163	503914			
		B		2	1	0	502164	503915			
	B		1	0	1	502165	503916				
	B		1	0	1	502166	503917				
	B		1	0	0	502167	503918				
	B		1	0	0	502168	503919				
		C	surface				502171	503920			
		C	flush				502172	503921			
		RD	surface				502177	503926			
		RD	flush				502178	503927			
		W	surface				503008	503007			
		W	flush				503006	503005			
	Sprinter 906 & 907 & 910	B			2	1	2	501970	503902	√	√
		B			1	0	1	501971	503903	√	√
B				2	1	0	502034	503905	√	√	
B				1	0	0	502035	503906	√	√	
W		surface					502175	503924		√	
W		flush					502176	503925		√	
Mitsubishi	Express (Australien & New Zealand)	D	surface				502171	503920			
		D	flush				502172	503921			
	C	surface				502171	503920				
	C	flush				502172	503921				
	D	surface				502171	503920				
Nissan	NV 200	D	flush				502172	503921			
		W	surface				503197	503945			
	NV 300	C	surface				502171	503920			
		C	flush				502172	503921			
		D	surface				502171	503920			
		D	flush				502172	503921			
	NV 400	B			2	1	2	502039	503909		
		B			2	1	0	502041	503911		
		B			1	0	1	502042	503912		
		B			1	0	0	502043	503913		
	C	surface				502181	503930				
	C	flush				502182	503931				
Primastar	C	surface				502171	503920				
	C	flush				502172	503921				
	D	surface				502171	503920				
	D	flush				502172	503921				
Opel	Combo High roof SWB & LWB	D	surface				503121	503940			
		D	flush				503120	503939			
	B		2	1	2	502039	503909				
	B		2	1	0	502041	503911				

Køretøjsliste - godkendte monteringsæt til Dahl Docking Systemer - kun til kørestole

Bilmærke	Bilmodel	Position af skulderseleforankring	Gulvbeslag type	Til B-Stolpe			MK II	Vario	FMVSS 207/ CMVSS 207	FMVSS 210/ CMVSS 210
				Antal dockinger	Sædeunderstel	Skulderseleforankring				
		B		1	0	1	502042	503912		
		B		1	0	0	502043	503913		
		C	surface				502181	503930		
		C	flush				502182	503931		
	Vivaro X 82 & X 83	C	surface				502171	503920		
		C	flush				502172	503921		
		D	surface				502171	503920		
		D	flush				502172	503921		
	Zafira Life	C	surface				503302	503949		
		C	flush				503301	503946		
		B		1	0	0	503303	503950		
		B		1	0	1	503304	503951		
		B		2	1	0	503305	503952		
		B		2	1	2	503306	503953		
Peugeot	Boxer Y	C	surface				502171	503920		
		C	flush				502172	503921		
		W	surface				502179	503928		
		W	flush				502180	503929		
	Expert X	C	surface				502171	503920		
		C	flush				502172	503921		
		W	surface				502177	503926		
		W	flush				502178	503927		
	Expert & Traveller KO	C	surface				503302	503949		
		C	flush				503301	503946		
		B		1	0	0	503303	503950		
		B		1	0	1	503304	503951		
		B		2	1	0	503305	503952		
		B		2	1	2	503306	503953		
	Partner, Tripod/Allied drop floor conversion	B		2	1	2	503461	503954		
Renault	Master X62	B		2	1	2	502039	503909		
		B		2	1	0	502041	503911		
		B		1	0	1	502042	503912		
		B		1	0	0	502043	503913		
		C	surface				502181	503930		
		C	flush				502182	503931		
	Trafic X 82 & X 83	C	surface				502171	503920		
		C	flush				502172	503921		
		D	surface				502171	503920		
		D	flush				502172	503921		
		D	surface				501026	503900		
		D	flush				501027	503901		
Toyota	Proace	C	surface				502171	503920		
		C	flush				502172	503921		
		RD	surface				502177	503926		
		RD	flush				502178	503927		
	Proace & Proace Verso 2017-	C	surface				503302	503949		
		C	flush				503301	503946		
		B		1	0	0	503303	503950		
		B		1	0	1	503304	503951		
		B		2	1	0	503305	503952		
		B		2	1	2	503306	503953		
VW	Caddy, ITEK drop floor conversion	B		2	1	2	503255	503947		
				2	1	0	503310	503948		
	Crafter (2006-2016)	B		2	1	2	501970	503902	√	√
		B		1	0	1	501971	503903	√	√
		B		2	1	0	502034	503905	√	√
		B		1	0	0	502035	503906	√	√
		W	surface				502175	503924		√
		W	flush				502176	503925		√
		D	surface				502171	503920		
		D	flush				502172	503921		
	Crafter 2017 -	C	surface				503142	503941		
		C	flush				503143	503942		
		W	surface				503145	503944		
		W	flush				503144	503943		
		D	surface				502171	503920		
		D	flush				502172	503921		
	VW T5 & T6	B		1	0	1	501973	503904		
		B		1	0	0	502036	503907		
		B		2	1	0	502037	503908		
		B		2	1	2	502040	503910		
		C	surface				502171	503920		
		C	flush				502172	503921		
		W	surface				502173	503922		
		W	flush				502174	503923		
		RD	surface				502177	503926		
		RD	flush				502178	503927		
	T6, Zawatzky Centervan, Drop floor conversion	B		2	1	2	502368	503937		
		B		2	1	0	502369	503938		
	T5 & T6 Colorado, GM Coachwork, Drop floor conversion	B		2	1	2	502285	503933		
		B		1	0	1	502286	503934		
		B		2	1	0	502287	503935		
		B		1	0	0	502288	503936		

Symboler: B = B stolpe / C = C stolpe / D = D stolpe / W = Vinduesramme / RD = Bagdør

Art. nr. 501552

ACA Drop Floor Conversion:

Jeep Renegade

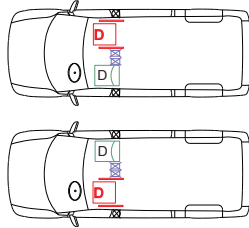
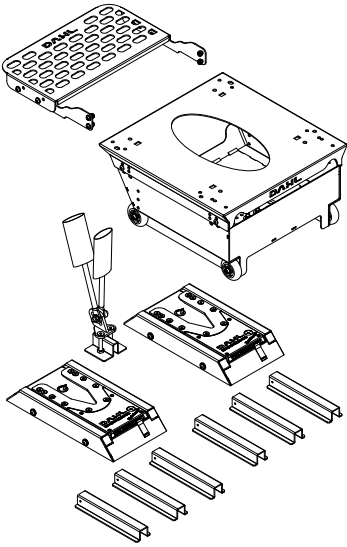

Art. nr. 503665

Freedom Drop Floor Conversion:

Citroën Jumpy & Spacetourer KO
Opel Zafira Life
Peugeot Expert & Traveller KO
Toyota Proace & Proace Verso 2017-

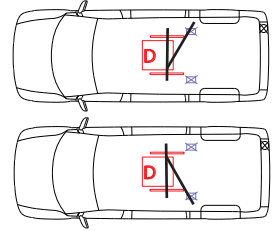
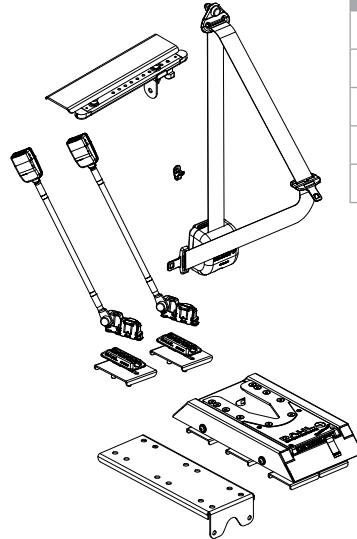

Art. nr. 503902

MB Sprinter 906, 907 & 910
VW Crafter (2006-2016)

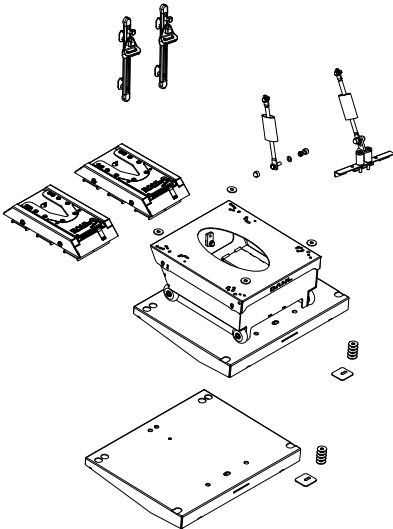

FMVSS/CMVSS
207/210

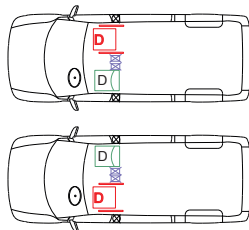

Art. nr. 503903

MB Sprinter 906, 907 & 910
VW Crafter (2006-2016)

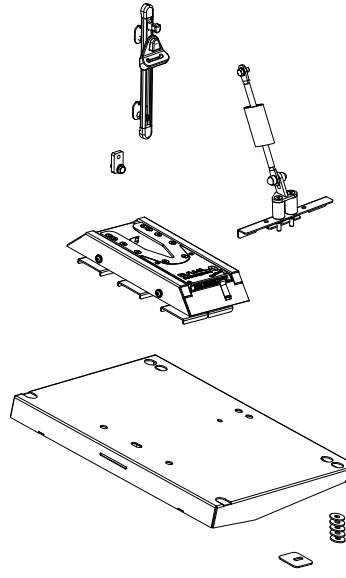

FMVSS/CMVSS
207/210

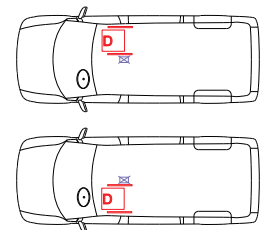

Art. nr. 503904

VW T5 & T6

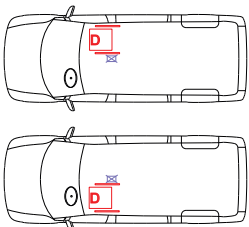
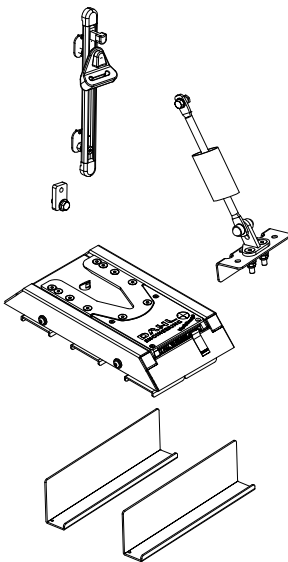

Art. nr. 503905

MB Sprinter 906, 907 & 910
VW Crafter (2006-2016)

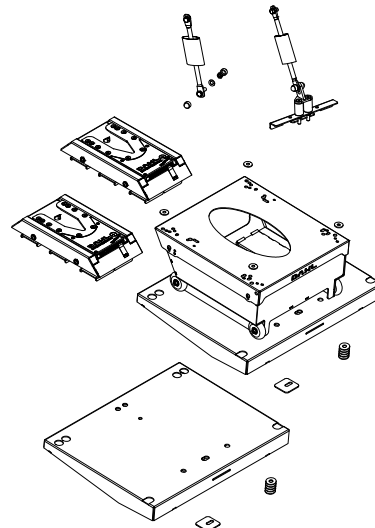

FMVSS/CMVSS
207/210

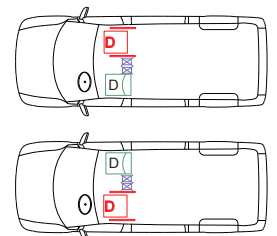

Dahl VarioDock™ System - godkendte monteringsæt KUN til kørestole

Art. nr. 503906

MB Sprinter 906, 907 & 910
VW Crafter (2006-2016)

FMVSS/CMVSS
207/210

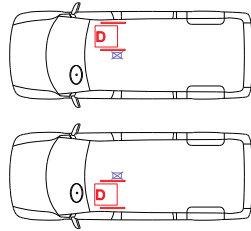
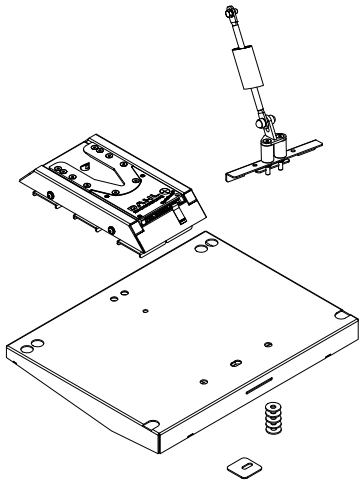

Art. nr. 503907

VW T5 & T6

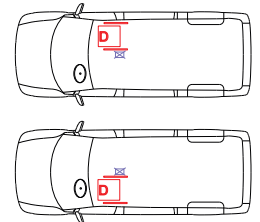
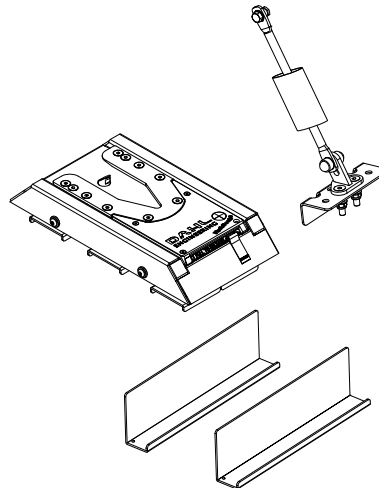

Art. nr. 503908

VW T5 & T6

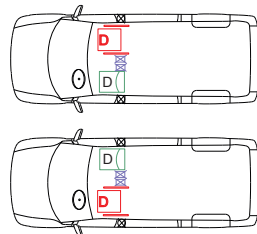
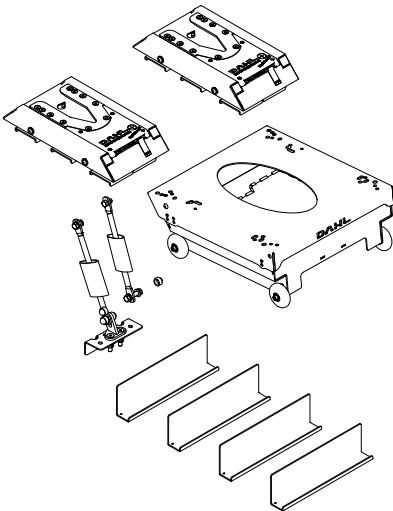

Art. nr. 503909

Renault Master X62
Opel Movano X62
Nissan NV400

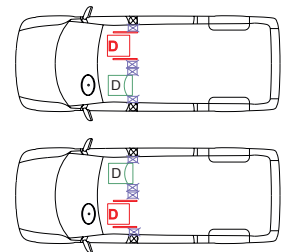
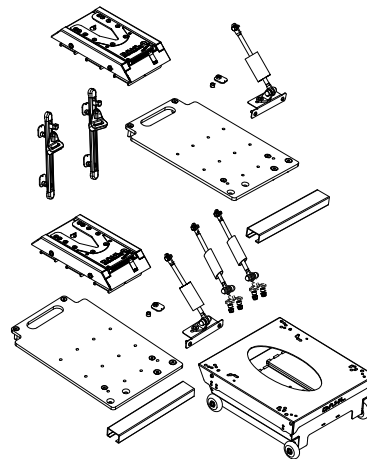

Art. nr. 503910

VW T5 & T6

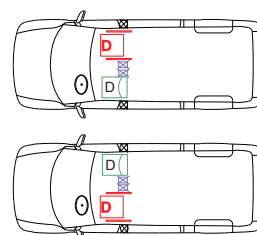
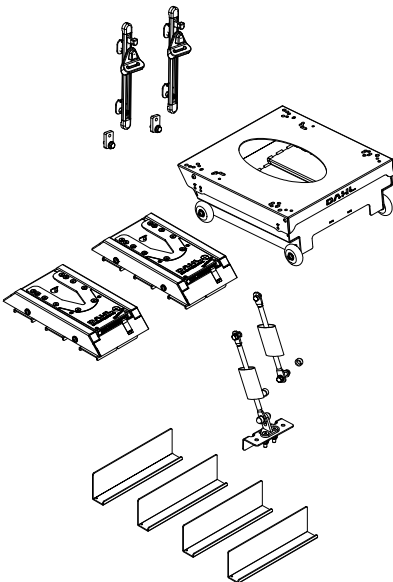

Art. nr. 503911

Renault Master X62
Opel Movano X62
Nissan NV400

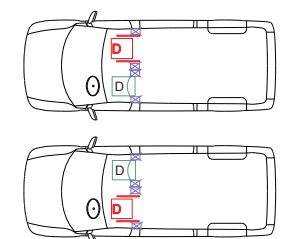
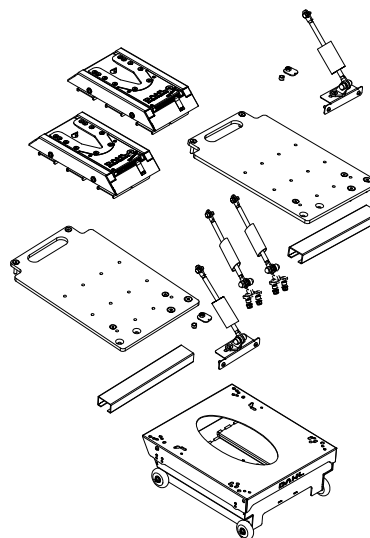

Dahl VarioDock™ System - godkendte monteringsæt KUN til kørestole

Art. nr. 503912

Renault Master X62
Opel Movano X62
Nissan NV400

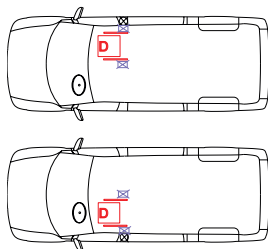
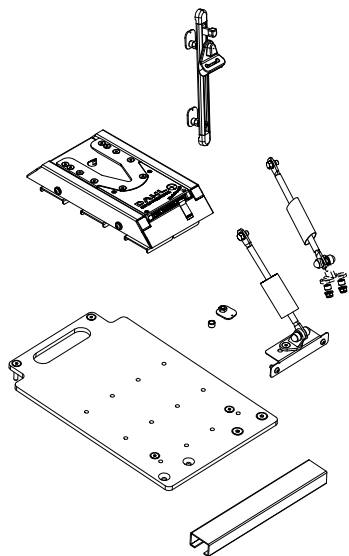

Art. nr. 503913

Renault Master X62
Opel Movano X62
Nissan NV400

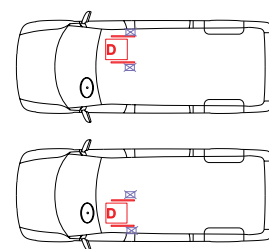
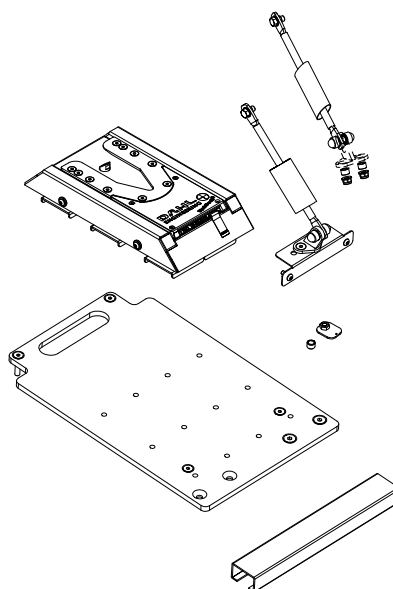

Art. nr. 503914

MB Vito & V-Class W447

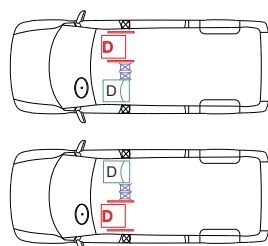
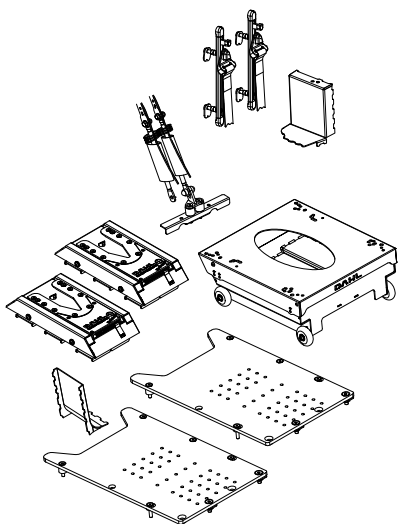

Art. nr. 503915

MB Vito & V-Class W447

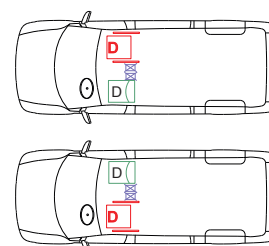
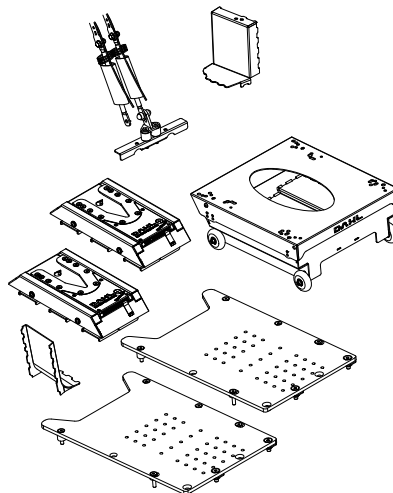

Art. nr. 503916

MB Vito & V-Class W447

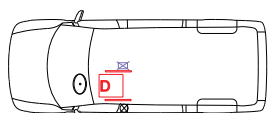
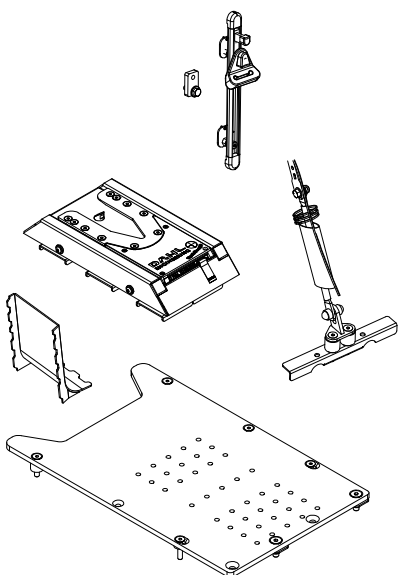

Art. nr. 503917

MB Vito & V-Class W447

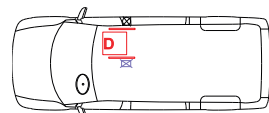
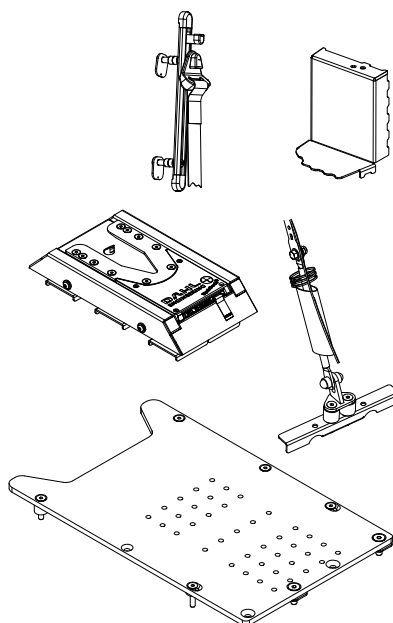

Dahl VarioDock™ System - godkendte monteringsæt KUN til kørestole

Art. nr. 503918
MB Vito & V-Class W447

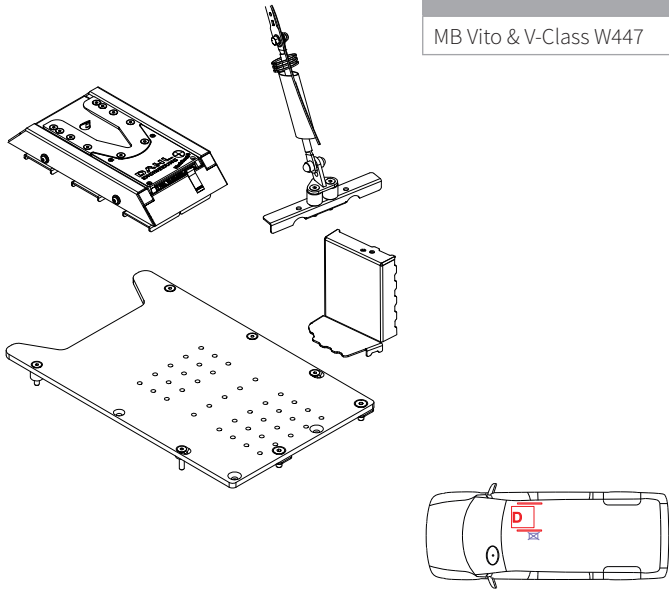

Art. nr. 503919
MB Vito & V-Class W447

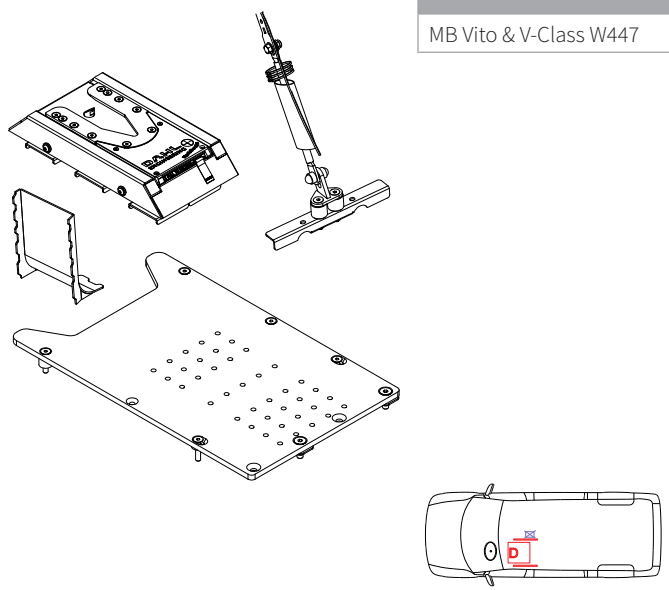

Art. nr. 503920

- Fiat Talento 2016-
- MAN TGE 2017-
- MB Sprinter 906, 907 & 910
- Mitsubishi Express X82 (AU & NZ)
- Nissan Primastar
- Nissan NV300
- Opel Vivaro X83 & X82
- Renault Traffic X83 & X82
- VW Crafter -2016
- VW Crafter 2017-

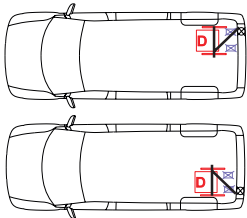

Art. nr. 503920

- Citroen Jumper Y
- Citroen Jumpy X
- Fiat Ducato X250
- Fiat Talento
- Fiat Scudo VX270
- Ford Transit Custom V362
- MB VITO W 639 & 447
- Nissan Primastar
- Nissan NV300
- Opel Vivaro X83 & X82
- Peugeot Boxer Y
- Peugeot Expert X
- Renault Traffic X83 & X82
- Toyota Proace
- VW T5 & T6

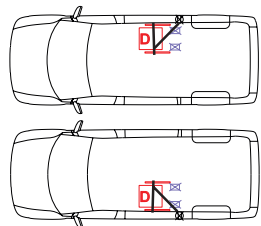

Art. nr. 503921

- Fiat Talento 2016-
- MAN TGE 2017-
- MB Sprinter 906, 907 & 910
- Mitsubishi Express X82 (AU & NZ)
- Nissan NV300
- Nissan Primastar
- Opel Vivaro X83 & X82
- Renault Traffic X83 & X82
- VW Crafter -2016
- VW Crafter 2017-

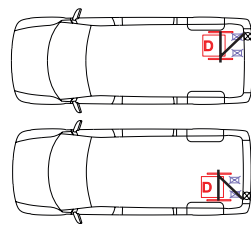

Art. nr. 503921

- Citroen Jumper Y
- Citroen Jumpy X
- Fiat Ducato X250
- Fiat Scudo X270
- Fiat Talento
- Ford Transit Custom V362
- MB VITO W 639 & 447
- Nissan Primastar
- Nissan NV300
- Peugeot Boxer Y
- Peugeot Expert X
- Opel Vivaro X83 & X82
- Renault Traffic X83 & X82
- Toyota Proace
- VW T5 & T6

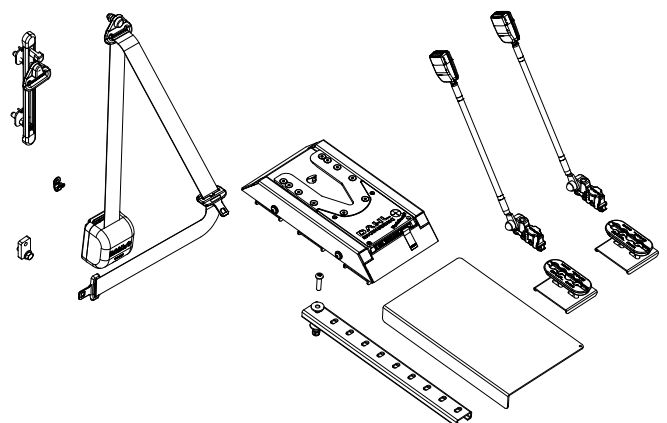
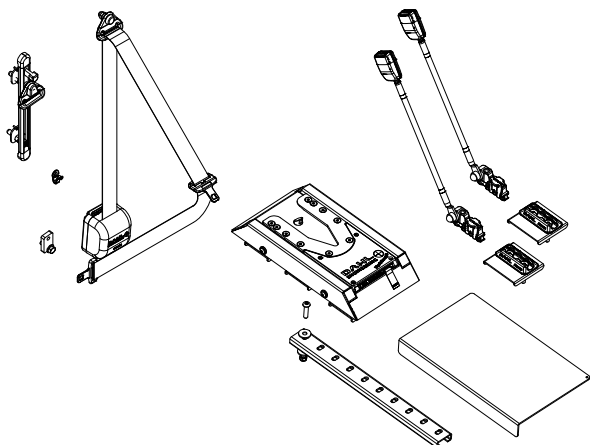
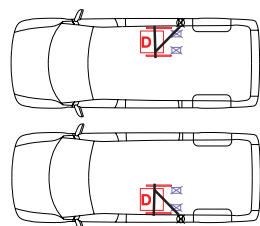

Dahl VarioDock™ System - godkendte monteringsæt KUN til kørestole

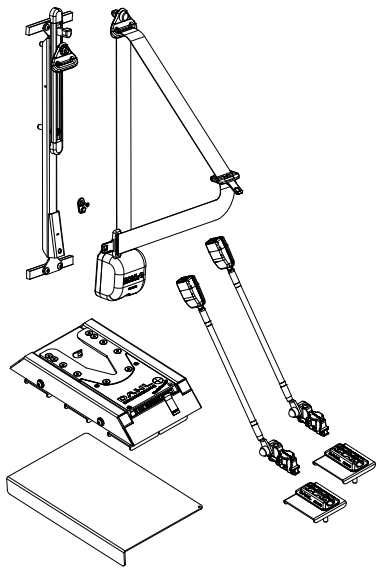

Art. nr. 503922
VW T5 & T6

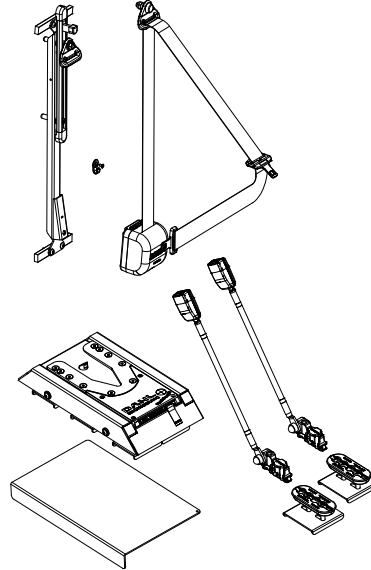
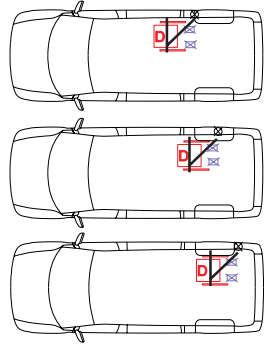

Art. nr. 503923
VW T5 & T6

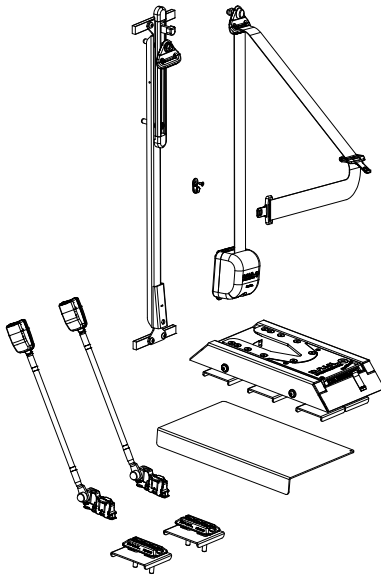
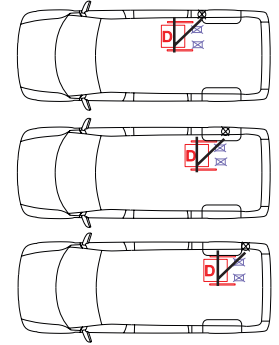

Art. nr. 503924
MB Sprinter
906 & 907 & 910
VW Crafter (2006-2016)

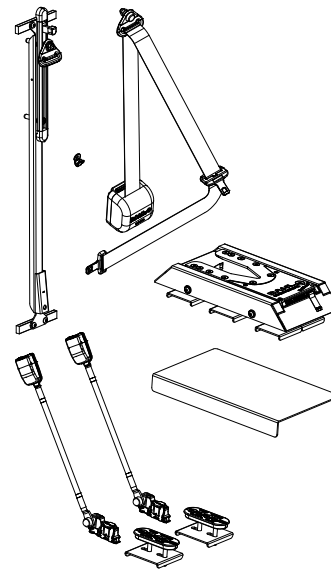
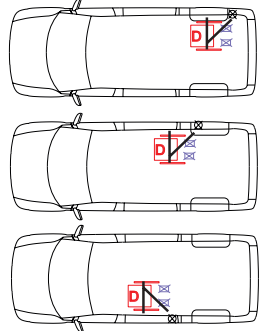

Art. nr. 503925
MB Sprinter
906 & 907 & 910
VW Crafter (2006-2016)

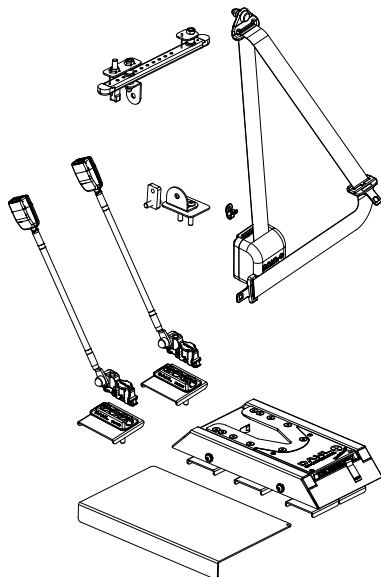
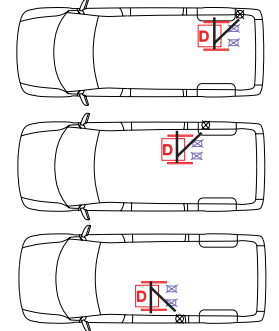

Art. nr. 503926
Citroën Jumpy X
Fiat Scudo X270
Ford Transit Custom V362
MB Vito & V-Class W447
Peugeot Expert X
Toyota ProAce
VW T5 & T6

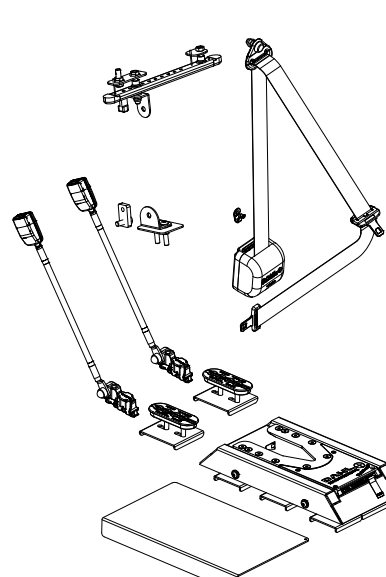
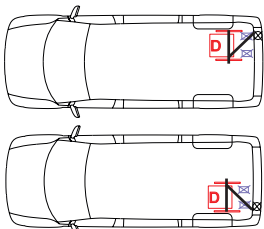

Art. nr. 503927
Citroën Jumpy X
Fiat Scudo X270
Ford Transit Custom V362
MB Vito & V-Class W447
Peugeot Expert X
Toyota ProAce
VW T5 & T6

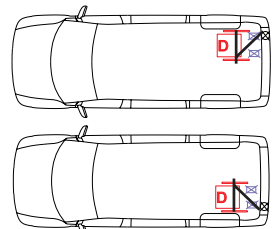

Dahl VarioDock™ System - godkendte monteringsæt KUN til kørestole

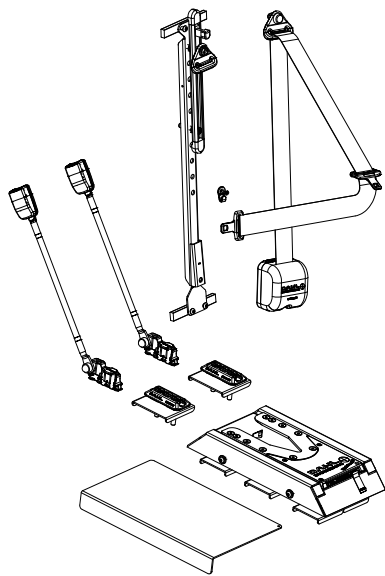

Art. nr. 503928
 Citroën Jumper Y
 Fiat Ducato X250
 Peugeot Boxer Y

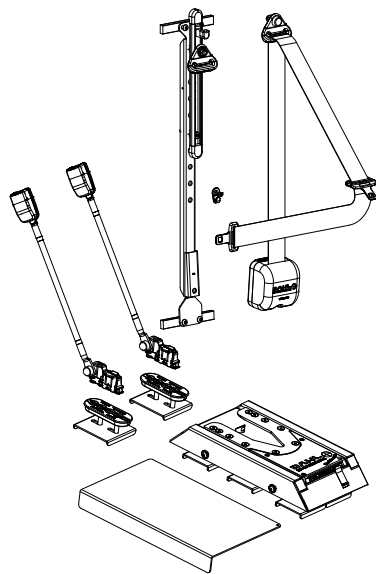
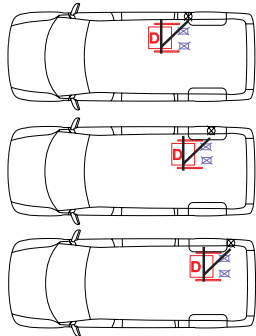

Art. nr. 503929
 Citroën Jumper Y
 Fiat Ducato X250
 Peugeot Boxer Y

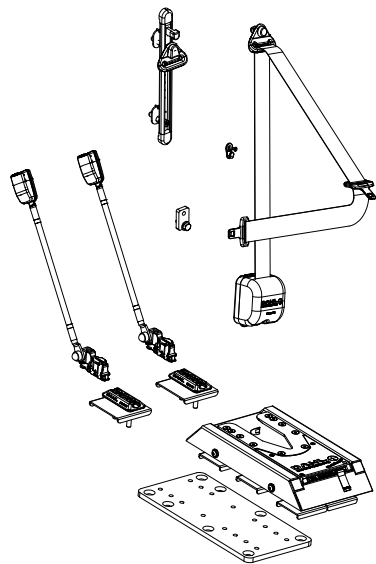
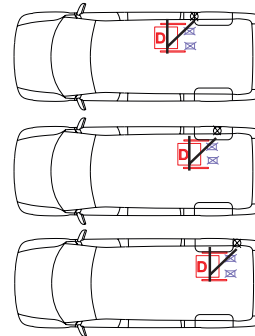

Art. nr. 503930
 Nissan NV 400
 Opel Movano X62
 Renault Master X62

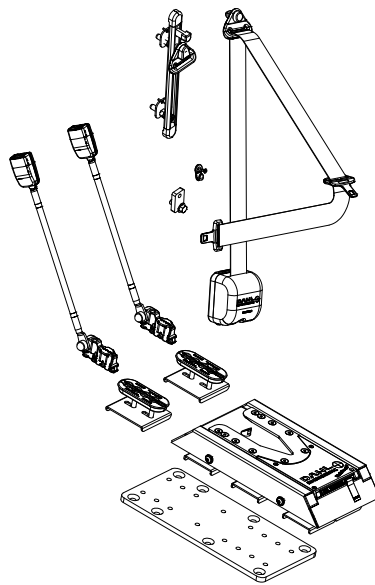
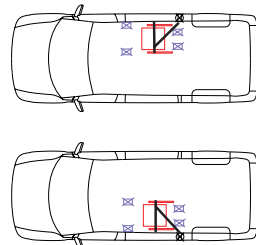

Art. nr. 503931
 Nissan NV 400
 Opel Movano X62
 Renault Master X62

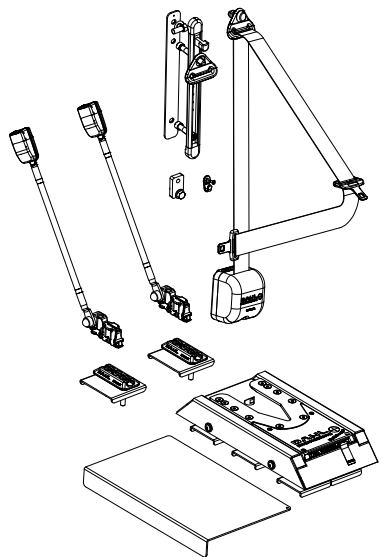
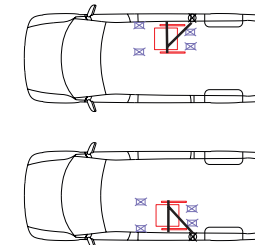

Art. nr. 503932
 Ford Transit V363

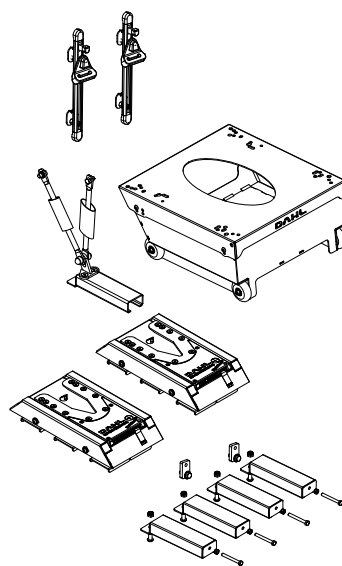
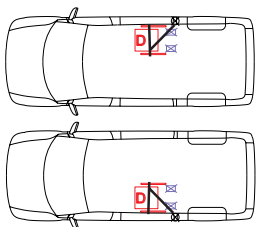

Art. nr. 503933
 GM Coachwork
 Drop floor conversion:
 VW Caravelle SE Colorado

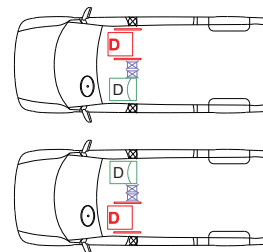

Art. nr. 503934

GM Coachwork
Drop floor conversion:
VW Caravelle SE Colorado

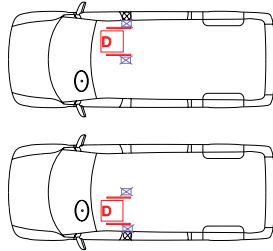
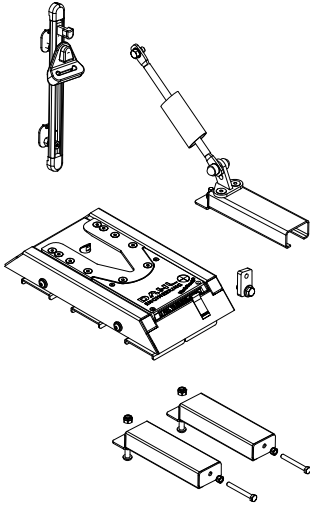

Art. nr. 503935

GM Coachwork
Drop floor conversion:
VW Caravelle SE Colorado

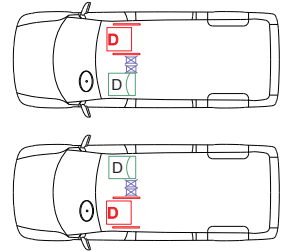
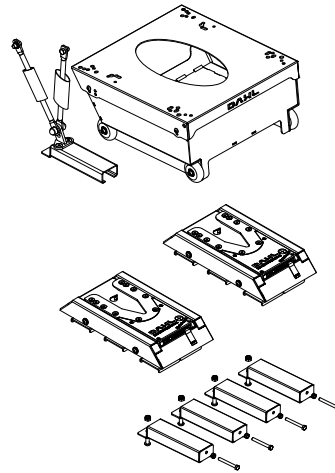

Art. nr. 503936

GM Coachwork
Drop floor conversion:
VW Caravelle SE Colorado

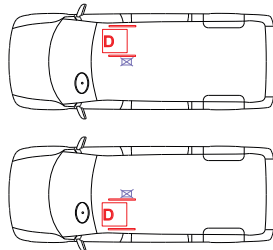
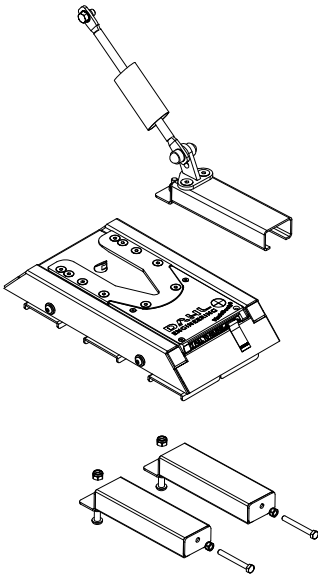

Art. nr. 503937

Zawatzky Drop Floor
Conversion:
VW T6 Centervan

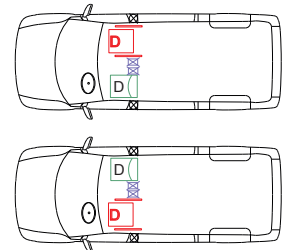
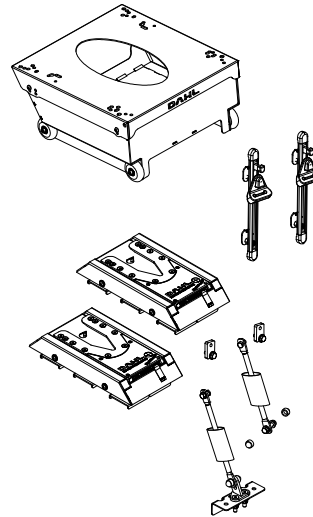

Art. nr. 503938

Zawatzky Drop Floor
Conversion:
VW T6 Centervan

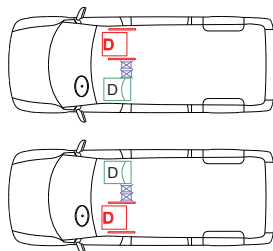
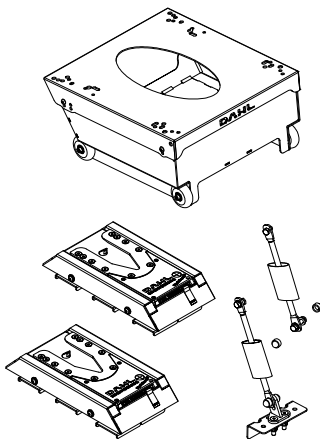

Art. nr. 503939

Fiat Doblo
High roof SWB & LWB
Opel Combo
High roof SWB & LWB

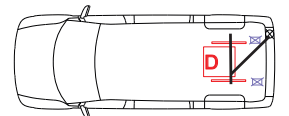
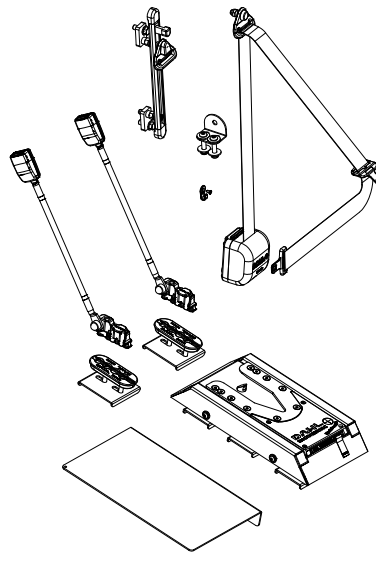

Dahl VarioDock™ System - godkendte monteringsæt KUN til kørestole

Art. nr. 503940
 Fiat Doblo
 High roof SWB & LWB
 Opel Combo
 High roof SWB & LWB

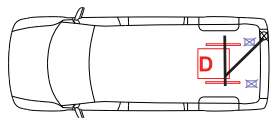
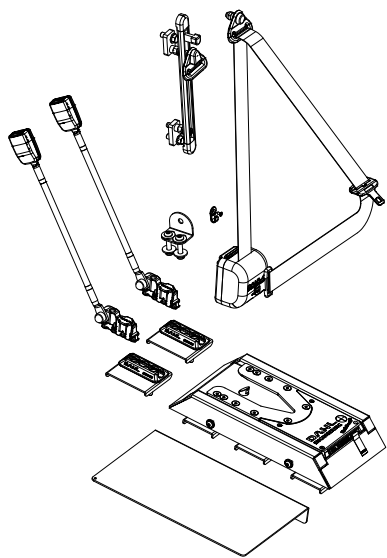

Art. nr. 503941
 VW Crafter 2017-
 MAN TGE 2017-

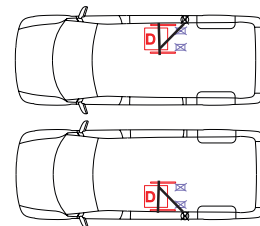
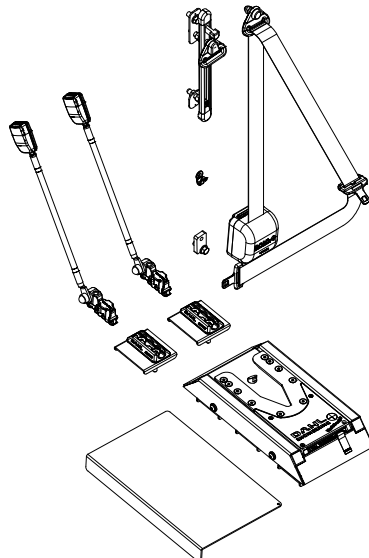

Art. nr. 503942
 VW Crafter 2017-
 MAN TGE 2017-

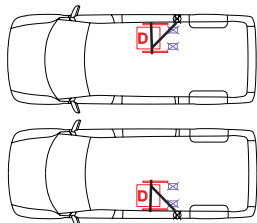
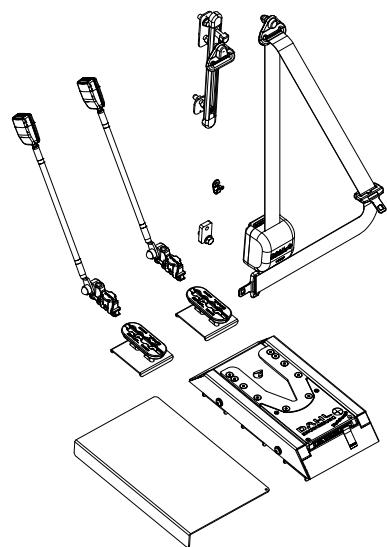

Art. nr. 503943
 VW Crafter 2017-
 MAN TGE 2017-

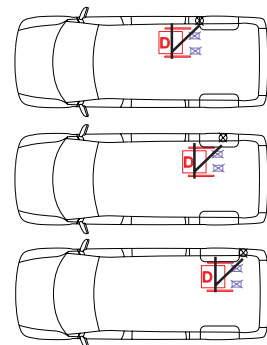
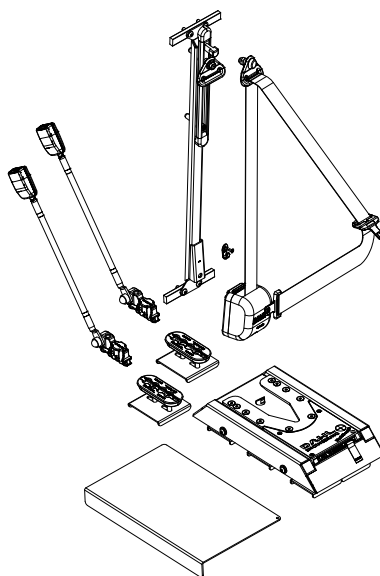

Art. nr. 503944
 VW Crafter 2017-
 MAN TGE 2017-

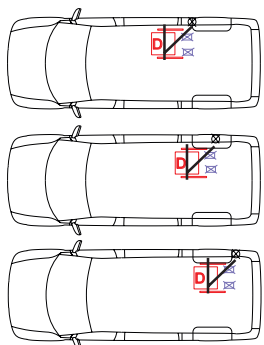
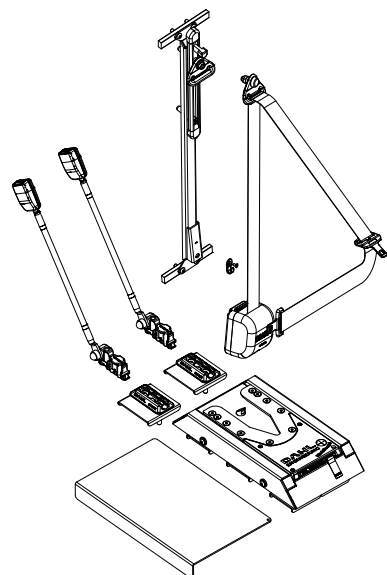

Art. nr. 503945
 Nissan NV 200

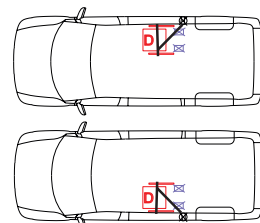
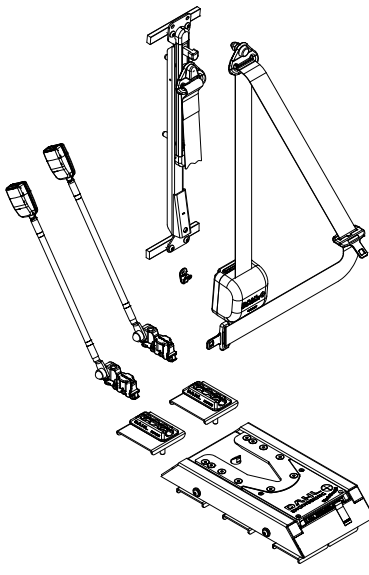

Dahl VarioDock™ System - godkendte monteringsæt KUN til kørestole

Art. nr. 503946

Citroën Jumpy & Spacetourer KO
Opel Zafira Life
Peugeot Expert & Traveller KO
Toyota Proace & Proace Verso 2016-

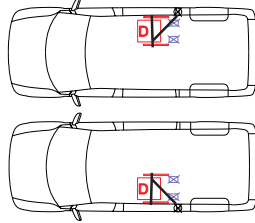
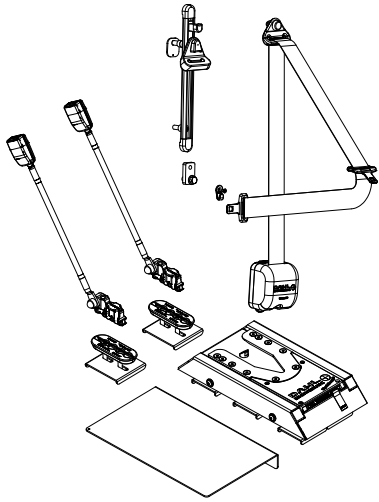

Art. nr. 503947

ITEK Drop Floor Conversion:
VW Caddy Active

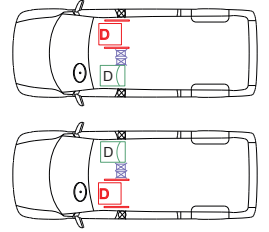
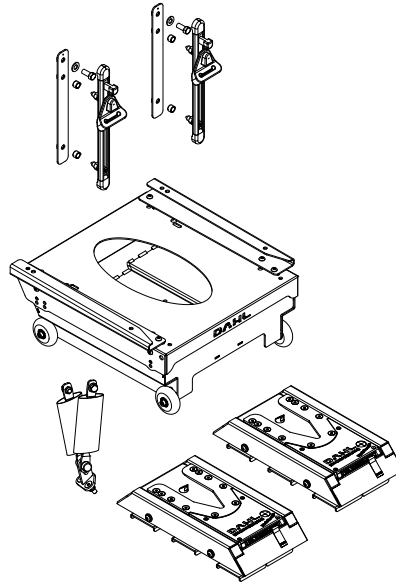

Art. nr. 503948

ITEK Drop Floor Conversion:
VW Caddy Active

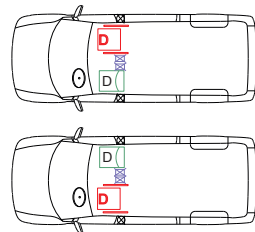
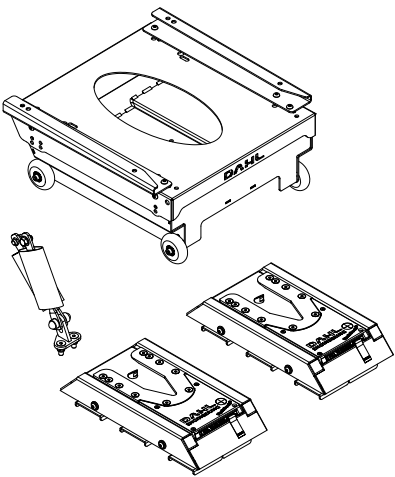

Art. nr. 503949

Citroën Jumpy & Spacetourer KO
Opel Zafira Life
Peugeot Expert & Traveller KO
Toyota Proace & Proace Verso 2016-

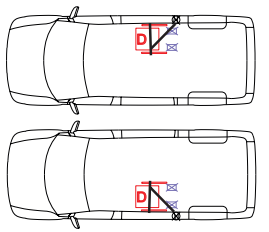
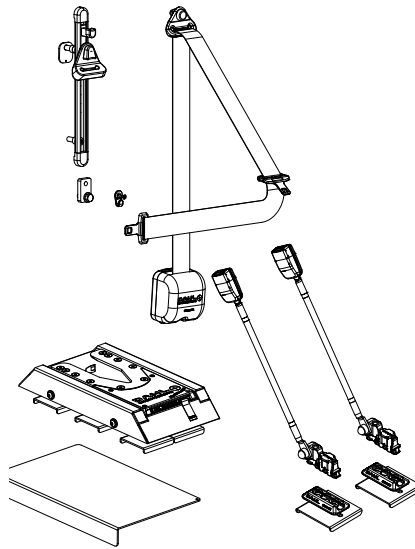

Art. nr. 503950

Citroën Jumpy & Spacetourer KO
Opel Zafira Life
Peugeot Expert & Traveller KO
Toyota Proace & Proace Verso 2016-

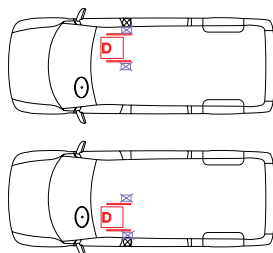
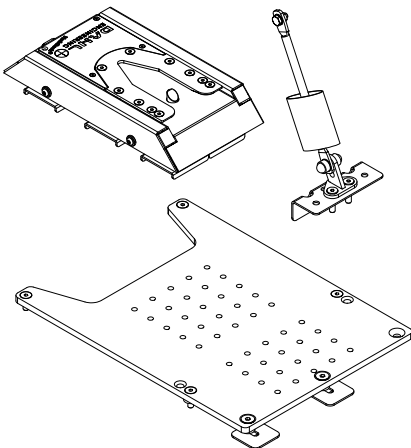

Art. nr. 503951

Citroën Jumpy & Spacetourer KO
Opel Zafira Life
Peugeot Expert & Traveller KO
Toyota Proace & Proace Verso 2017-

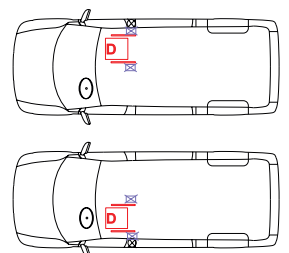
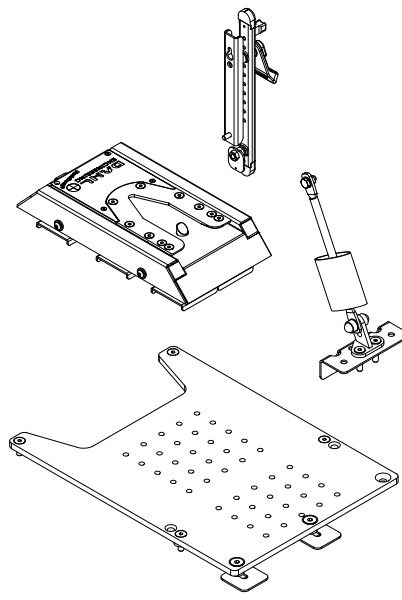

Dahl VarioDock™ System - godkendte monteringsæt KUN til kørestole

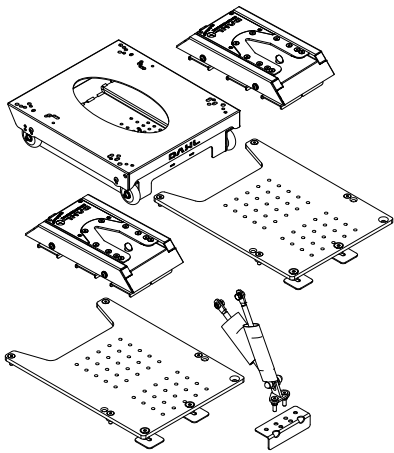

Art. nr. 503952

Citroën Jumpy & Spacetourer KO
 Opel Zafira Life
 Peugeot Expert & Traveller KO
 Toyota Proace & Proace Verso 2016-

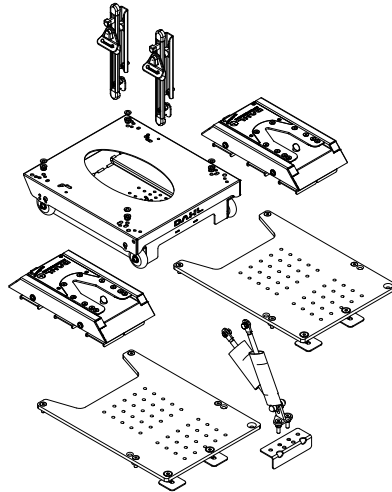
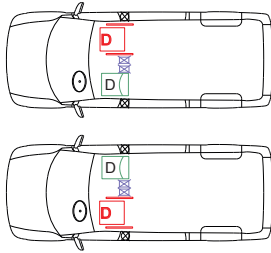

Art. nr. 503953

Citroën Jumpy & Spacetourer KO
 Opel Zafira Life
 Peugeot Expert & Traveller KO
 Toyota Proace & Proace Verso 2016-

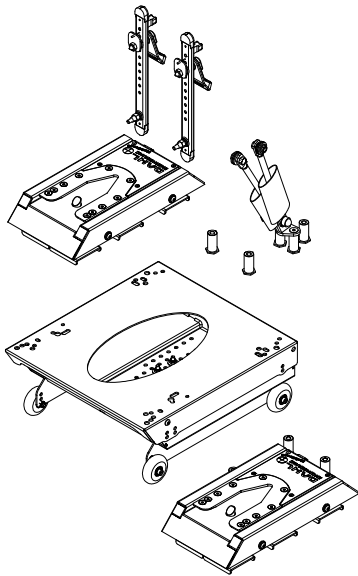
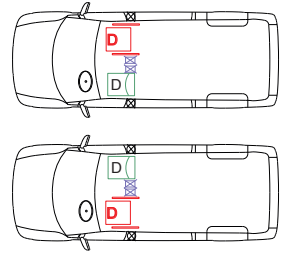

Art. nr. 503954

Tripod/Allied Drop Floor Conversion:
 Citroën Berlingo
 Peugeot Partner

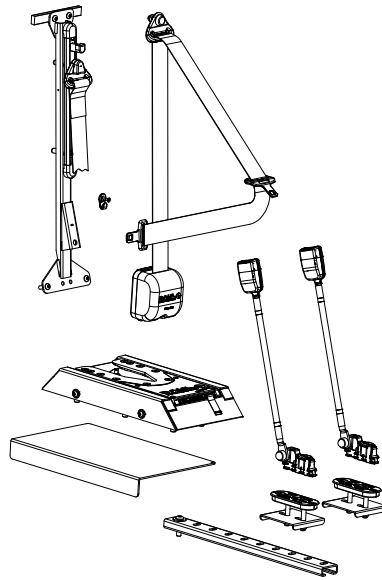
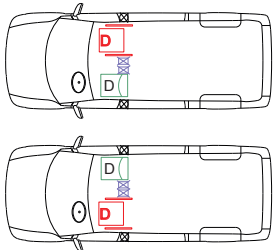

Art. nr. 503005

MB Vito
 MB V-Class 447

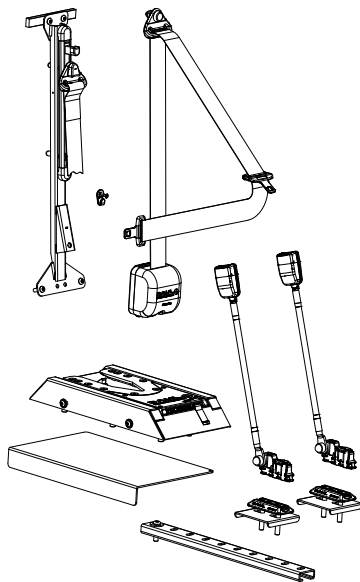
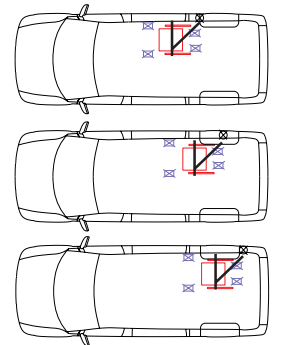

Art. nr. 503007

MB Vito
 MB V-Class 447

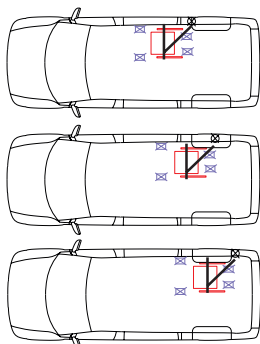

Dahl Docking Station Mk II



Art. nr.: 501750 - Dahl Docking Station MK II

Dahl Engineering's elektriske Docking System giver en hidtil uset fleksibilitet og sikkerhed for kørestolsbrugere. Docking systemet er som det første system blevet testet og TÜV godkendt i henhold til EU sikkerhedsdirektiver for personbiler (M1). Docking stationen har ved test vist sig at være så stærk, at den kan modstå en belastning svarende til en kørestolsvægt på over 200 kg + en passager, såfremt sikkerhedsselen monteres på traditionel vis i vognbunden.



Art. nr. 501750

Indholdet af et standard sæt - Dahl Docking System MK II.

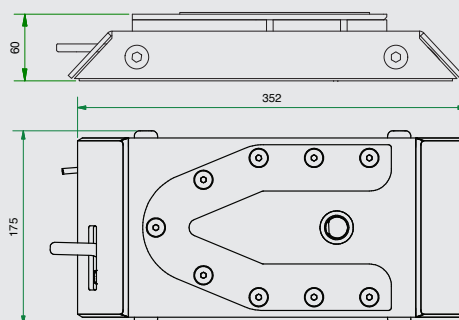
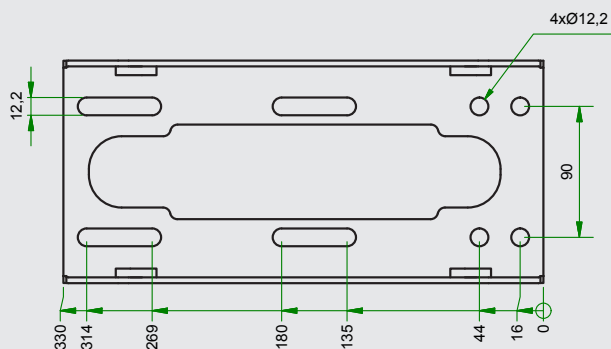

På vores hjemmeside kan du finde videoer og flere informationer om service og montering af DAHL docking stationen MK II.

Dahl Docking Station MK II - Enkel at betjene



En låseplade og en afstandsplade skal monteres under kørestolen. Når kørestolen køres mod docking stationen, føres den på plads ved hjælp af låsepladen og fastlåses automatisk.



Kørestolen frigøres ved at trykke på den røde knap i betjeningspanelet.

Funktionsbeskrivelse for Dahl Docking System MK II

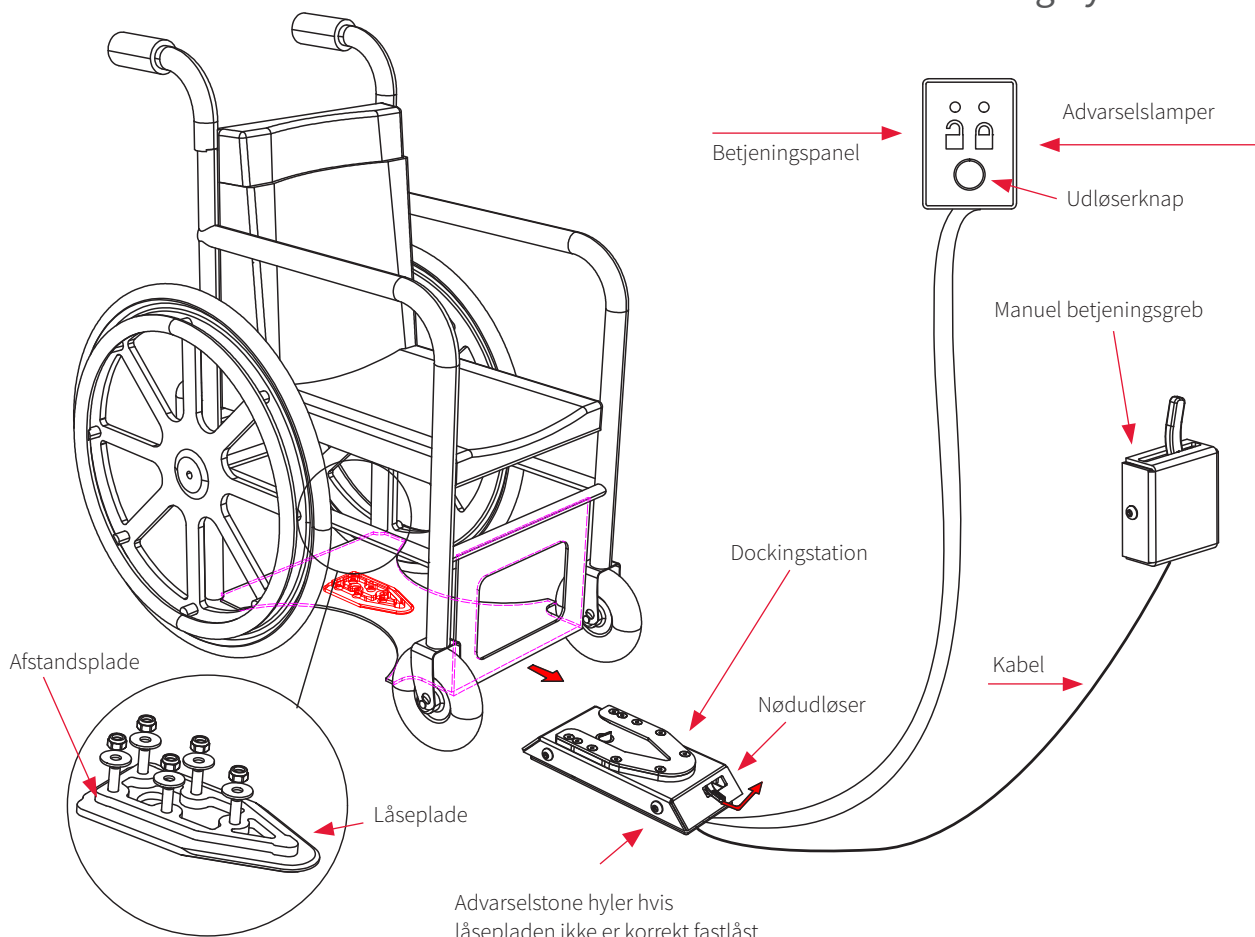

Tilbehør Dahl Docking System MK II og VarioDock™

Sædeunderstel til forankring af originale førerstole med Dahl Docking Station MKII og VarioDock

Dahl Docking Station MKII og VarioDock er ud over at være godkendt til fastspænding af kørestole også blevet testet og godkendt til forankring af et antal bilproducenters originale førersæder.

Disse understel med for borede huller kan forankres i Dahl Docking Station MK II og VarioDock og placeres på køretøjernes 1. sæderække, hvilket gør det muligt for fører og passager, at bytte plads.

Vores sædeunderstel er bl.a. testet i henhold til ECE-regulativ 14 og 17.

Forespørg venligst, hvilken sædeunderstel er bedst egnet til den specifikke bilmodel.



Art. nr. 501384
Fodstøtte

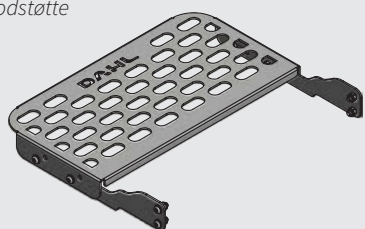

Art.nr. 503245
Højde 135-202 mm

Art.nr. 501448
Højde 135-202 mm (wide base)

Art.nr. 500650
Højde 174-241 mm

Art.nr. 502270
Højde 231-297 mm

Art.nr. 502214
Højde 231-297 mm (wide base)

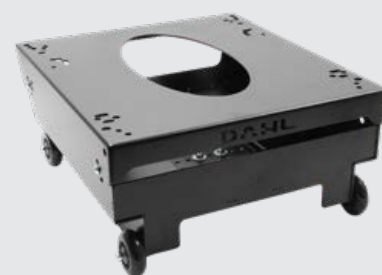

Sædeunderstellet kan samles i 36 forskellige positioner for optimal fleksibilitet og komfort. Bl.a. kan sædehøjde og -vinkel tilpasses.

Værktøj til nødudløsning

Art. nr. 503161



Tilbehør Dahl Docking System MK II

Afstandsplader til kørestolens låseplade

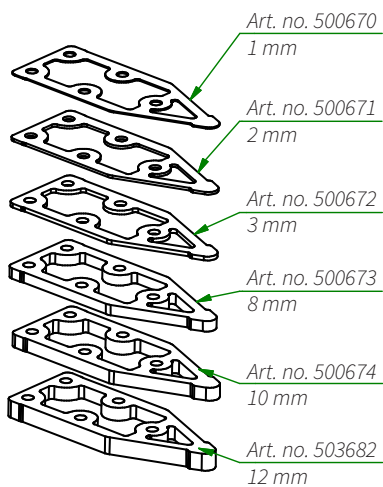

Art. nr. 503125
Låseplade med bolte og
8 mm afstandsstykke

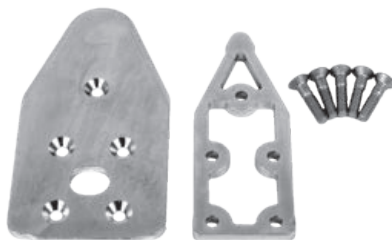

Afstandsplader til docking station

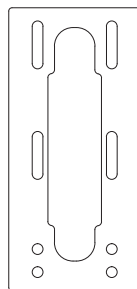

Art. nr. 500589
1 mm

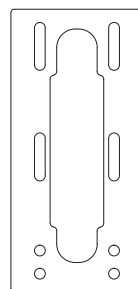

Art. nr. 500590
3 mm

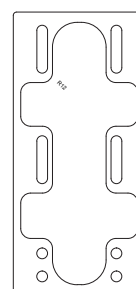

Art. nr. 502044
10 mm

Servicekits

Art.nr. 502010 - Servicekit til MK II, (frem til 05/2017)
Art.nr. 502493 - Servicekit til MK II, (06/2017-)
Art.nr. 503636 - Servicekit til VarioDock™

Manuel betjeningsgreb

Art. nr. 500680



Kabel til betjeningsgreb

Art. nr. 502418



Underkonsoller til Docking Station Mk II



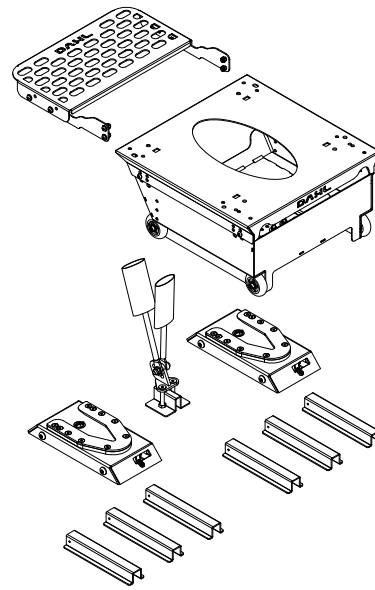

Art. nr. 501551
 ACA Dropfloor
 Conversion:
 Jeep Renegade

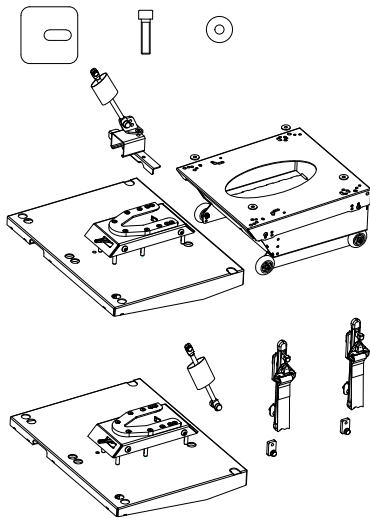
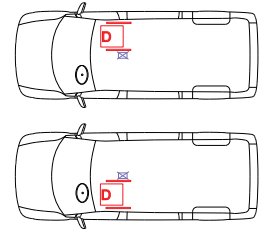

Art. nr. 501970
 MB Sprinter 906 & 907
 VW Crafter (2006-2016)

**FMVSS/CMVSS
 207/210**

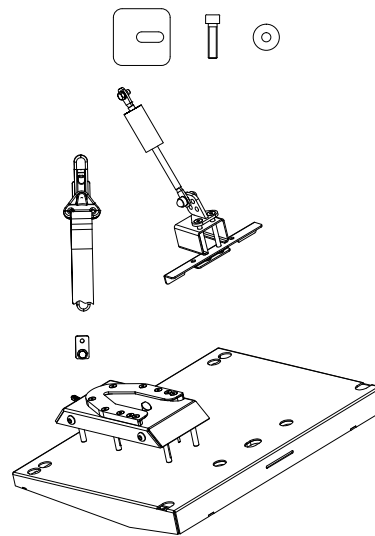
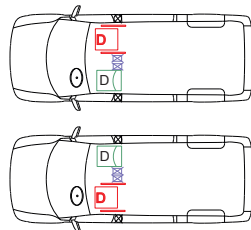

Art. nr. 501971
 MB Sprinter 906 & 907
 VW Crafter (2006-2016)

**FMVSS/CMVSS
 207/210**

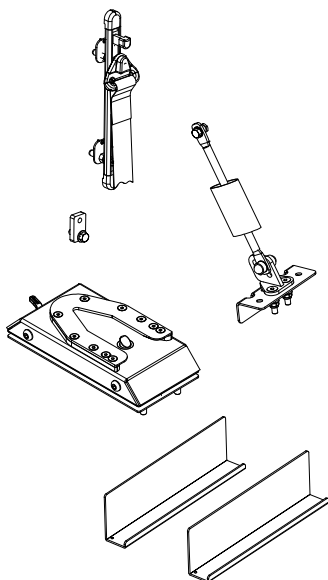
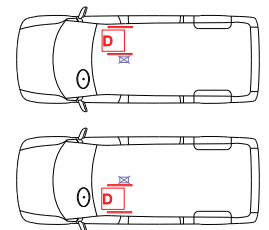

Art. nr. 501973
 VW T5 & T6

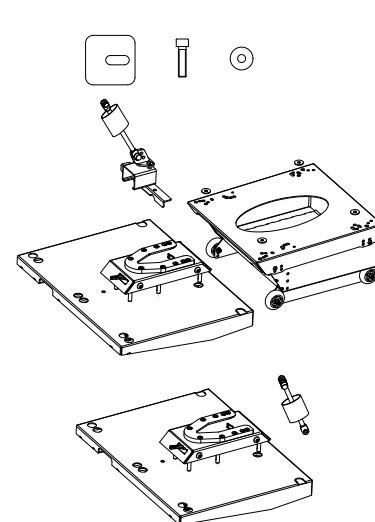
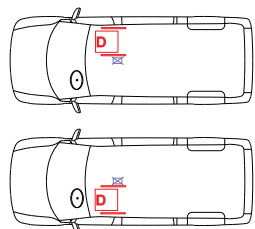

Art. nr. 502034
 MB Sprinter 906 & 907
 VW Crafter (2006-2016)

**FMVSS/CMVSS
 207/210**

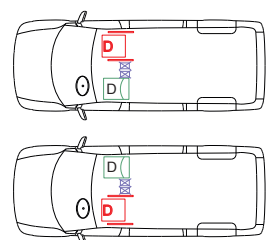

Dahl Docking Station MK II System - godkendte monteringsæt

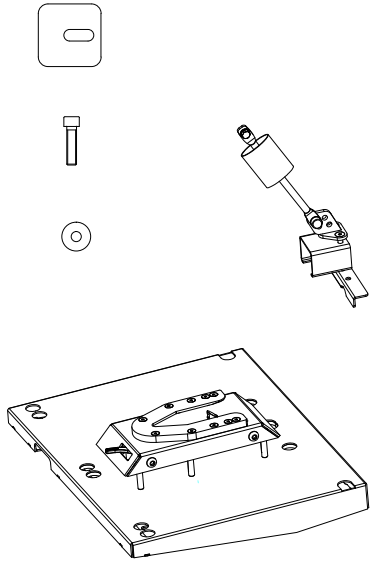

Art. nr. 502035
 MB Sprinter 906 & 907
 VW Crafter (2006-2016)

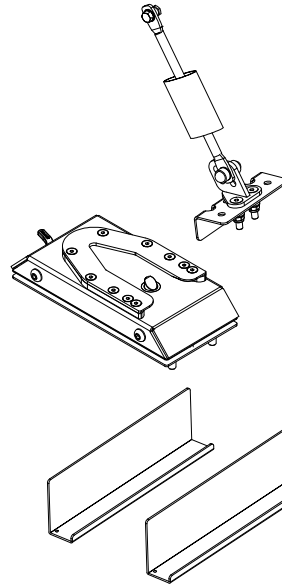
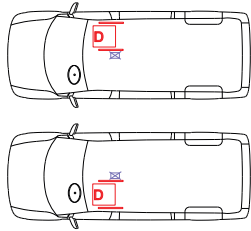

Art. nr. 502036
 VW T5 & T6

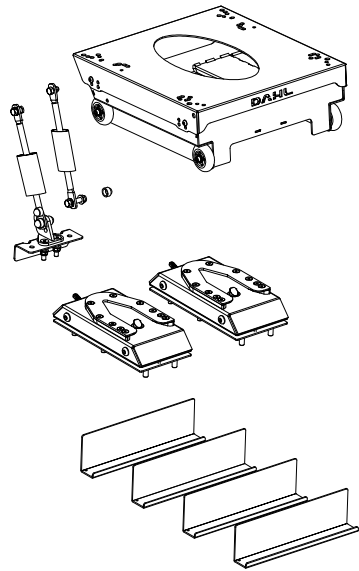
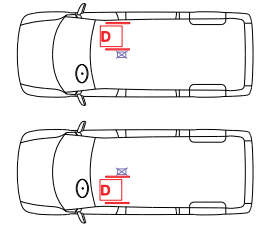

Art. nr. 502037
 VW T5 & T6

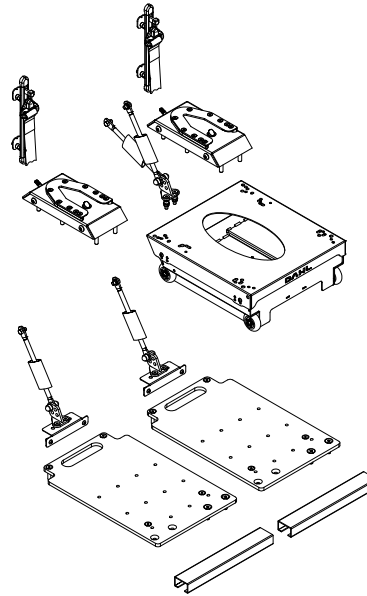
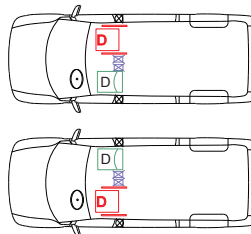

Art. nr. 502039
 Renault Master X62
 Opel Movano X62
 Nissan NV400

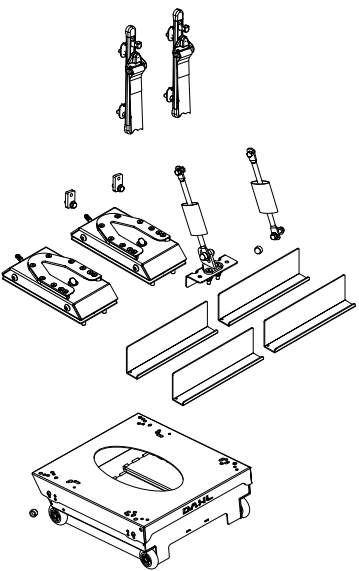
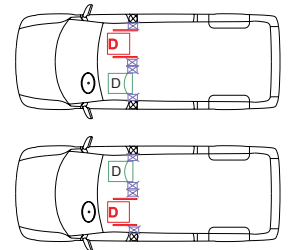

Art. nr. 502040
 VW T5 & T6

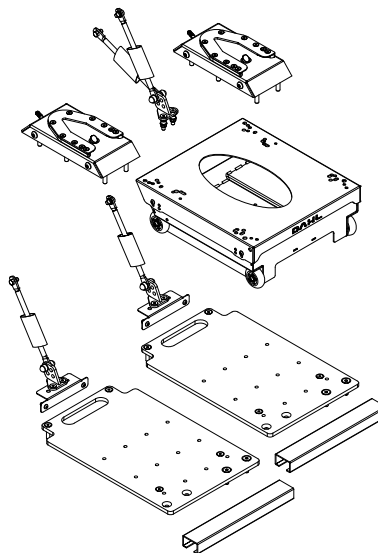
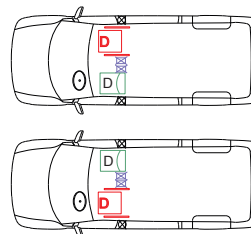

Art. nr. 502041
 Renault Master X62
 Opel Movano X62
 Nissan NV400

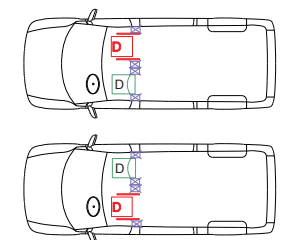

Dahl Docking Station MK II System - godkendte monteringsæt

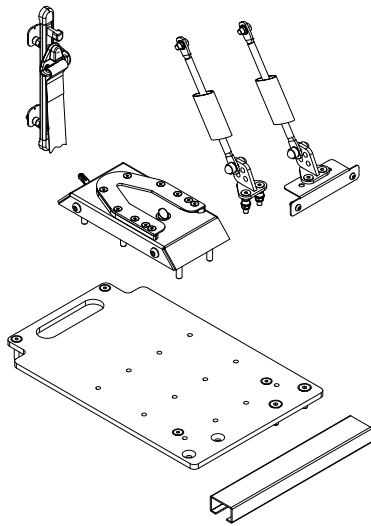

Art. nr. 502042
 Renault Master X62
 Opel Movano X62
 Nissan NV400

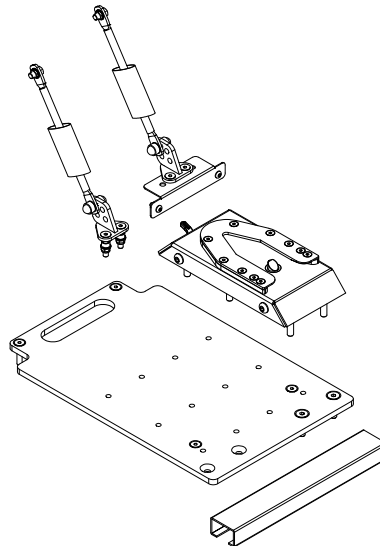
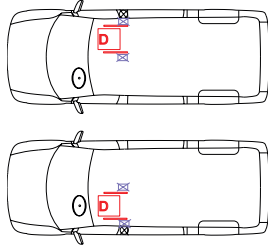

Art. nr. 502043
 Renault Master X62
 Opel Movano X62
 Nissan NV400

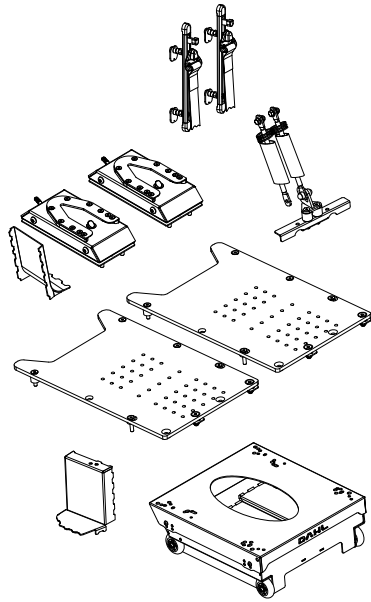
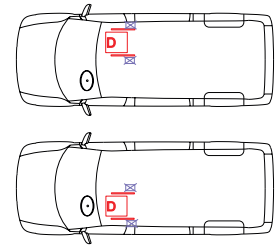

Art. nr. 502163
 MB Vito & V-Class W447

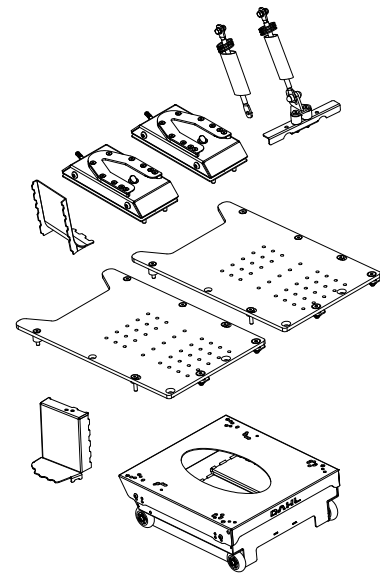
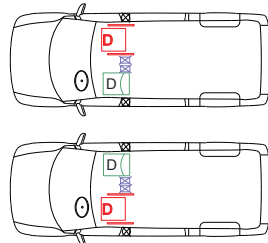

Art. nr. 502164
 MB Vito & V-Class W447

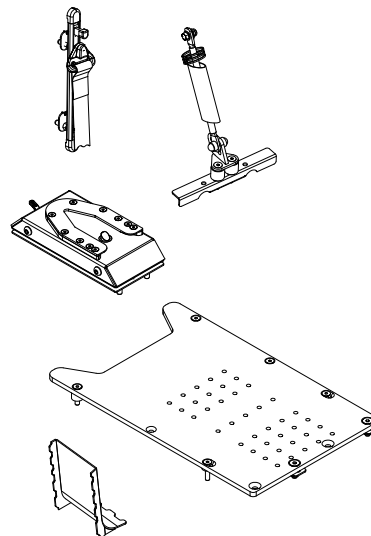
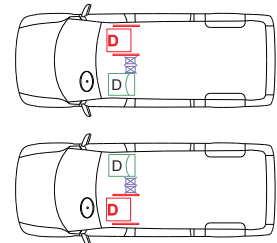

Art. nr. 502165
 MB Vito & V-Class W447

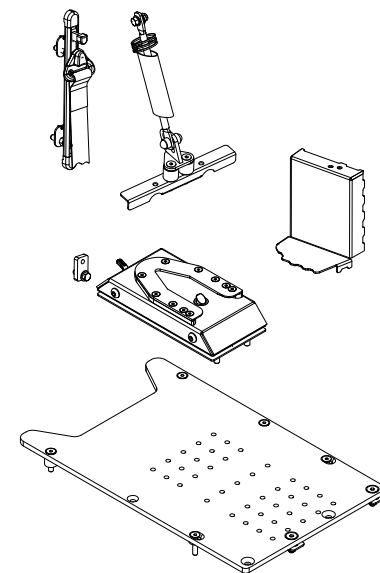
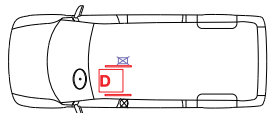

Art. nr. 502166
 MB Vito & V-Class W447

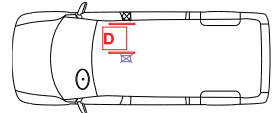

Dahl Docking Station MK II System - godkendte monteringsæt

Art. nr. 502167
MB Vito & V-Class W447

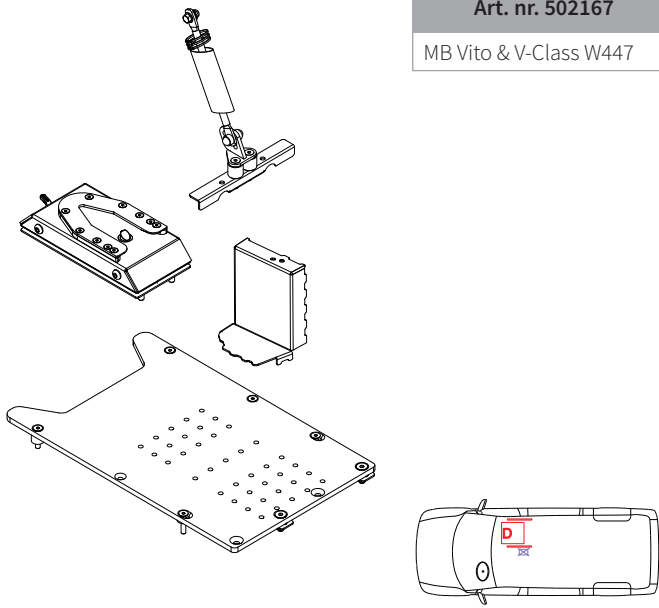

Art. nr. 502168
MB Vito & V-Class W447

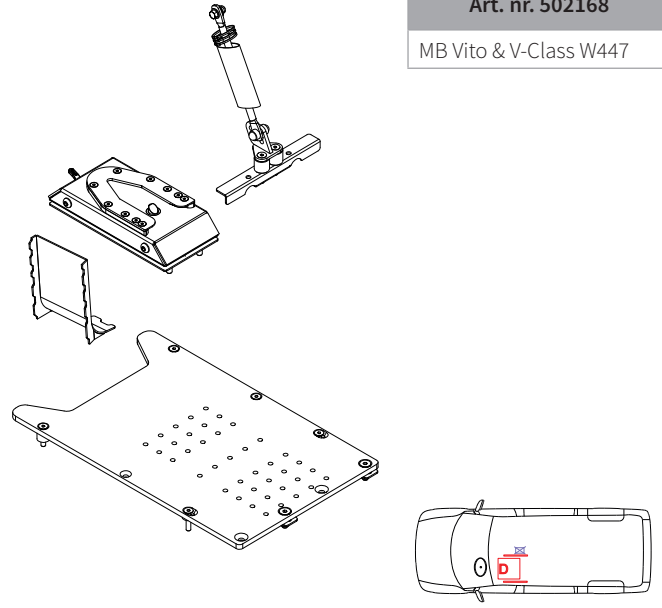

Art. nr. 502171
Fiat Talento 2016-
Man TGE 2017-
MB Sprinter 906 & 907 & 910
Mitsubishi Express (AU+NZ)
Nissan NV300
Nissan Primastar
Opel Vivaro X83 & X82
Renault Traffic X83 & X82
VW Crafter -2016
VW Crafter 2017-

Art. nr. 502171
Citroën Jumper Y
Citroën Jumpy X
Fiat Ducato X250
Fiat Scudo X270
Fiat Talento 2016-
Ford Transit Custom V362
MB Vito W639 & W447
Mitsubishi Express (AU+NZ)
Nissan NV300
Nissan Primastar
Opel Vivaro X83 & X82
Peugeot Boxer Y
Peugeot Expert X
Renault Traffic X83 & X82
Toyota Proace
VW T5 & T6

Art. nr. 502172
Fiat Talento 2016-
Man TGE 2017-
MB Sprinter 906 & 907 & 910
Mitsubishi Express (AU+NZ)
Nissan NV300
Nissan Primastar
Opel Vivaro X83 & X82
Renault Traffic X83 & X82
VW Crafter -2016
VW Crafter 2017-

Art. nr. 502172
Citroën Jumper Y
Citroën Jumpy X
Fiat Ducato X250
Fiat Scudo X270
Fiat Talento
Ford Transit Custom V362
MB Vito W639 & W447
Mitsubishi Express (AU+NZ)
Nissan NV300
Nissan Primastar
Opel Vivaro X83 & X82
Peugeot Boxer Y
Peugeot Expert X
Renault Traffic X83 & X82
Toyota Proace
VW T5 & T6

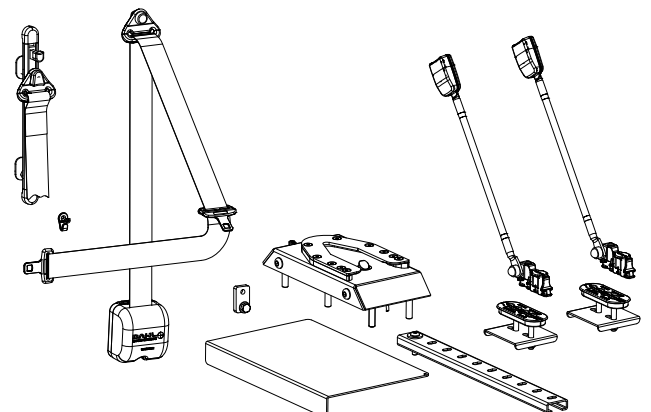
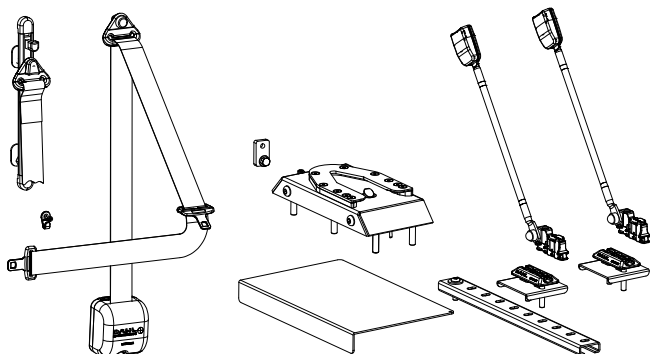

Dahl Docking Station MK II System - godkendte monteringsæt

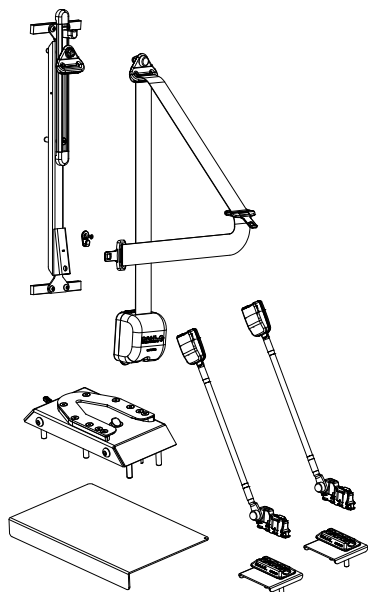

Art. nr. 502173
VW T5 & T6

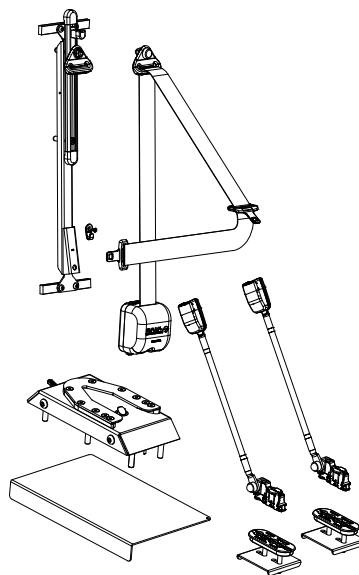
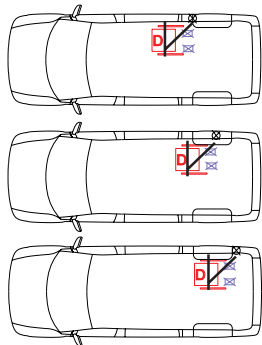

Art. nr. 502174
VW T5 & T6

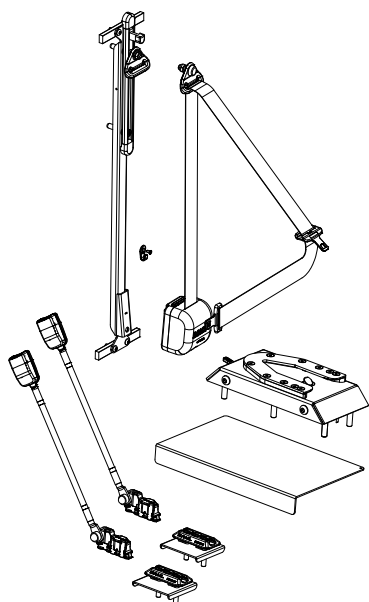
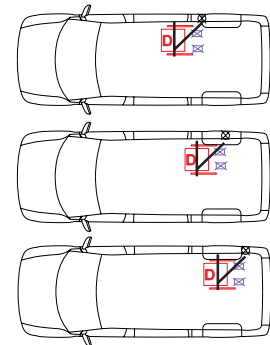

Art. nr. 502175
MB Sprinter
906 & 907 & 910
VW Crafter (2006-2016)

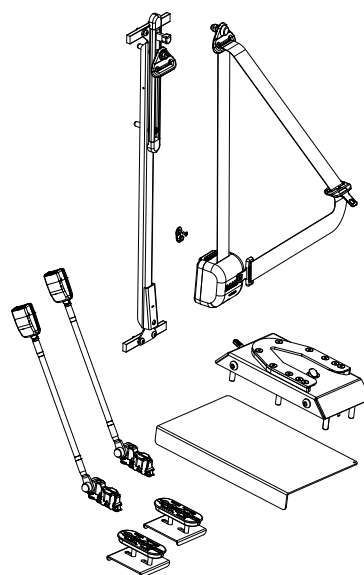
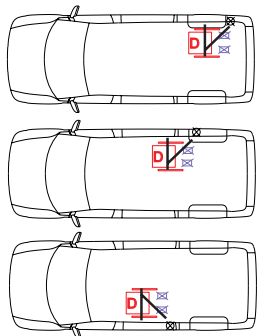

Art. nr. 502176
MB Sprinter
906 & 907 & 910
VW Crafter (2006-2016)

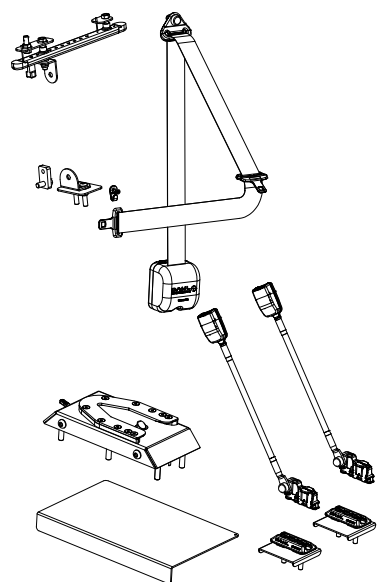
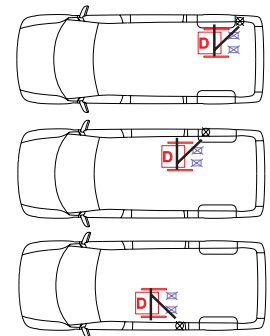

Art. nr. 502177
Citroën Jumpy X
Fiat Scudo X270
Ford Transit Custom V362
MB Vito & V-Class W447
Peugeot Expert X
Toyota ProAce
VW T5 & T6

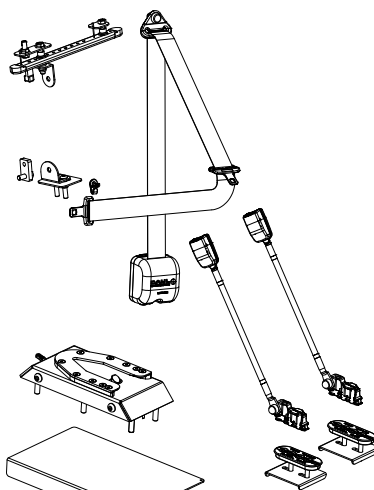
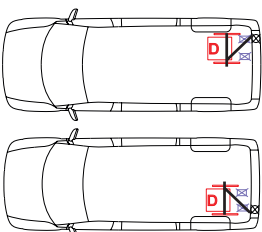

Art. nr. 502178
Citroën Jumpy X
Fiat Scudo X270
Ford Transit Custom V362
MB Vito & V-Class W447
Peugeot Expert X
Toyota ProAce
VW T5 & T6

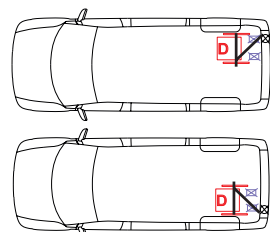

Dahl Docking Station MK II System - godkendte monteringsæt

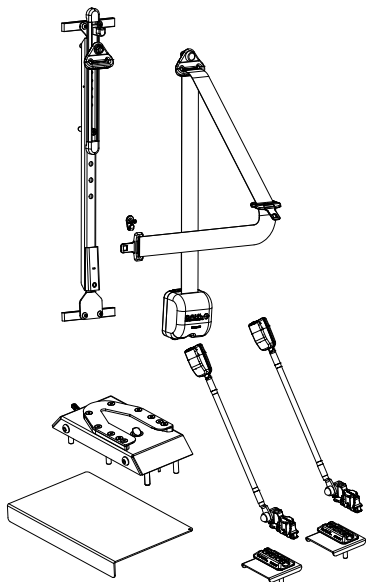

Art. nr. 502179
 Citroën Jumper Y
 Fiat Ducato X250
 Peugeot Boxer Y

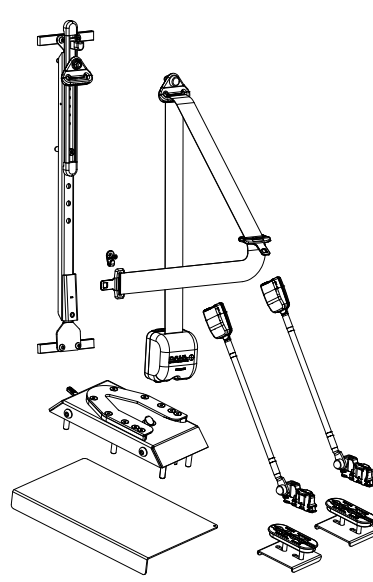
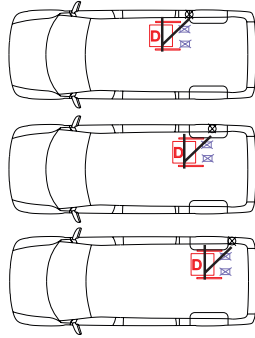

Art. nr. 502180
 Citroën Jumper Y
 Fiat Ducato X250
 Peugeot Boxer Y

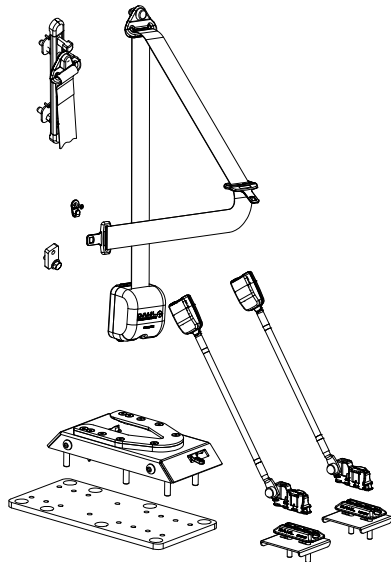
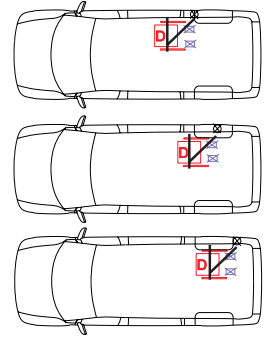

Art. nr. 502181
 Nissan NV 400
 Opel Movano X62
 Renault Master X62

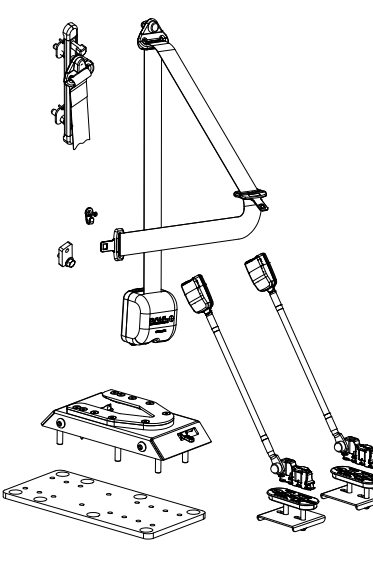
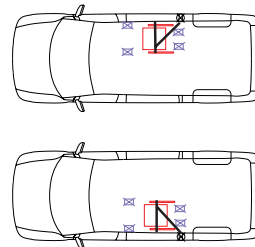

Art. nr. 502182
 Nissan NV 400
 Opel Movano X62
 Renault Master X62

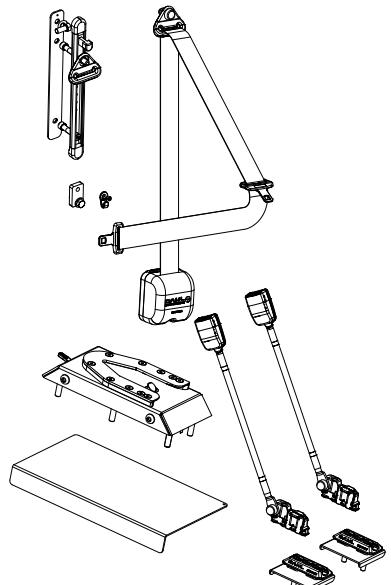
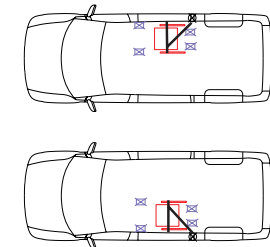

Art. nr. 502194
 Ford Transit V363

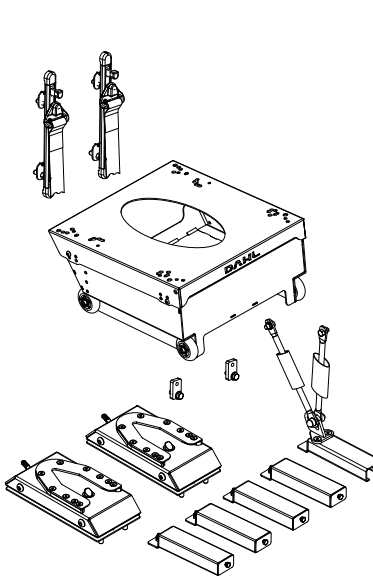
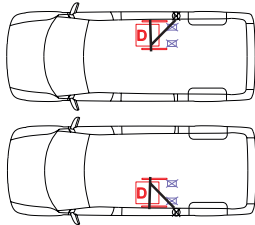

Art. nr. 502285
 GM Coachwork
 Drop floor conversion:
 VW Caravelle SE Colorado

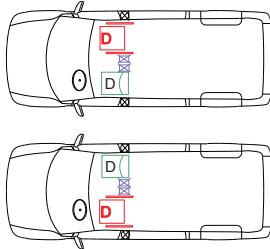

Dahl Docking Station MK II System - godkendte monteringsæt

Art. nr. 502286

GM Coachwork
Drop floor conversion:
VW Caravelle SE Colorado

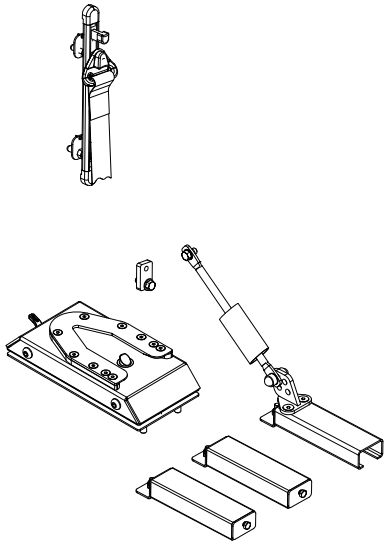

Art. nr. 502287

GM Coachwork
Drop floor conversion:
VW Caravelle SE Colorado

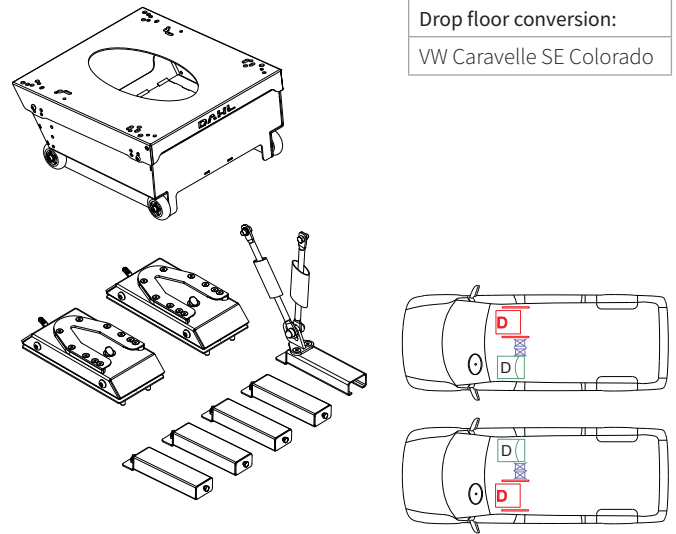

Art. nr. 502288

GM Coachwork
Drop floor conversion:
VW Caravelle SE Colorado

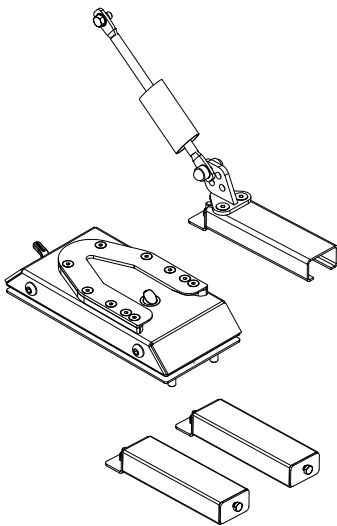

Art. nr. 502368

Zawatzky Drop Floor
Conversion:
VW Centervan T6

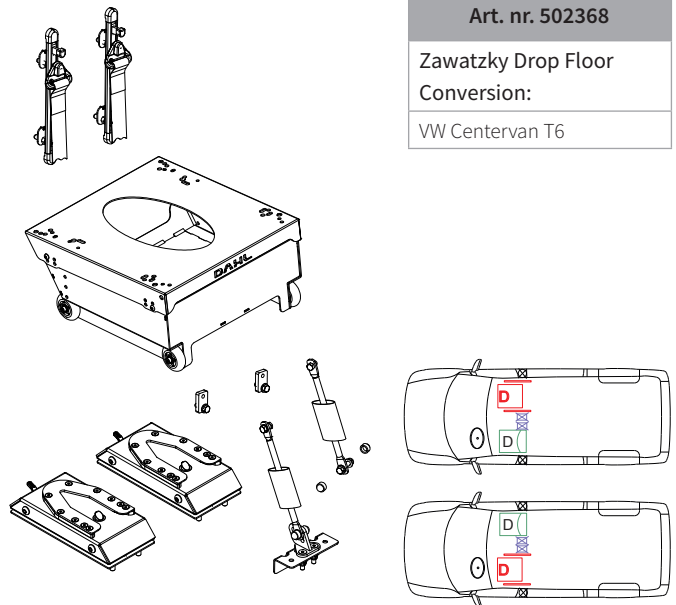

Art. nr. 502369

Zawatzky Drop Floor
Conversion:
VW Centervan T6

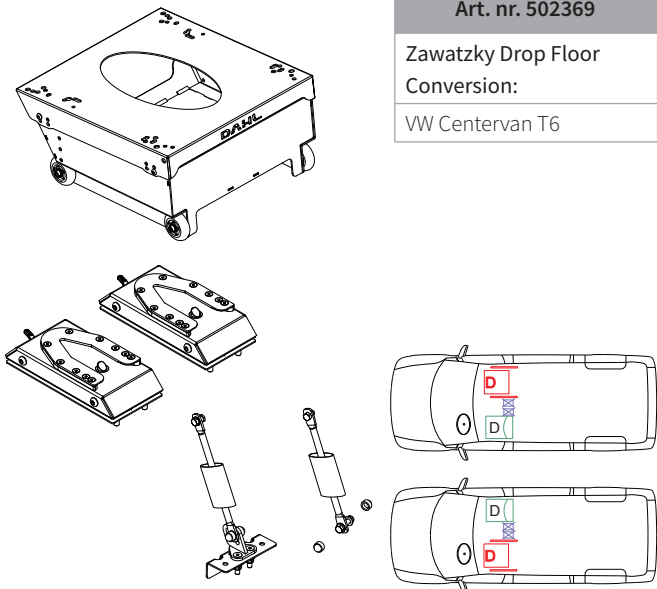

Art. nr. 503120

Fiat Doblo
High roof SWB & LWB
Opel Combo
High roof SWB & LWB

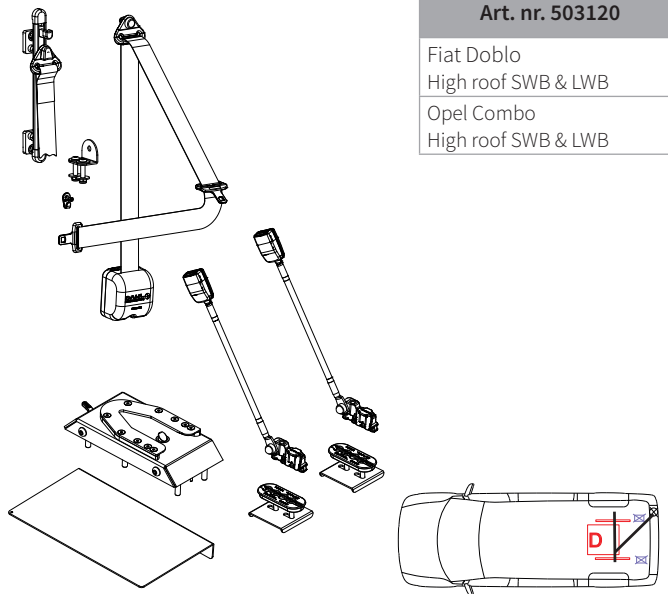

Dahl Docking Station MK II System - godkendte monteringsæt

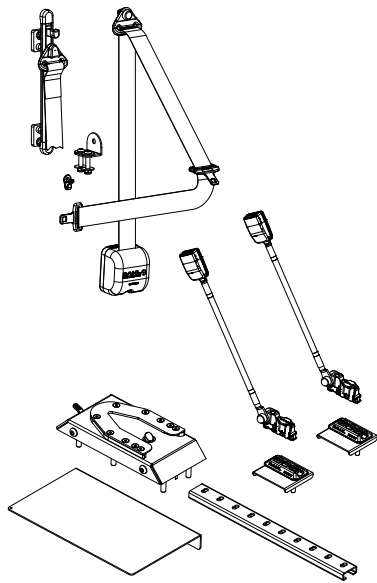

Art. nr. 503121
 Fiat Doblo
 High roof SWB & LWB
 Opel Combo
 High roof SWB & LWB

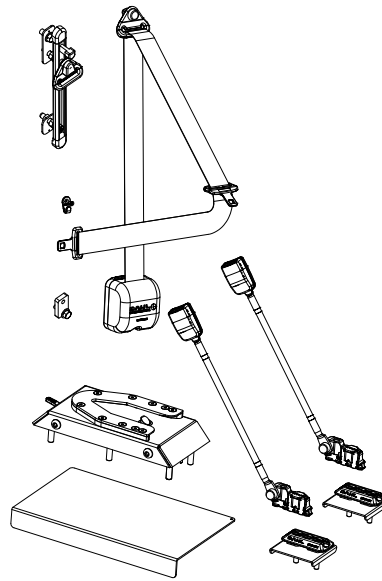
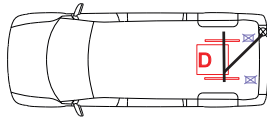

Art. nr. 503142
 VW Crafter 2017-
 MAN TGE 2017-

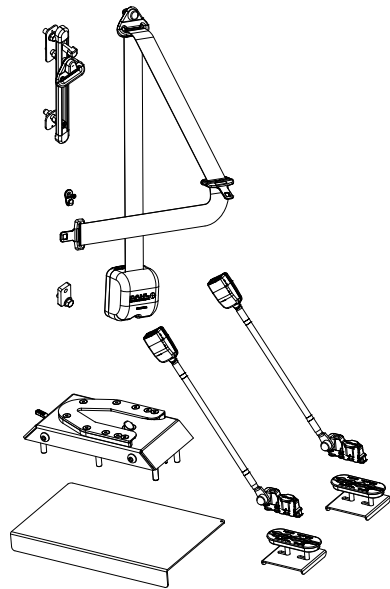
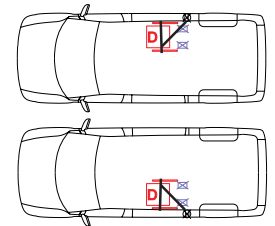

Art. nr. 503143
 VW Crafter 2017-
 MAN TGE 2017-

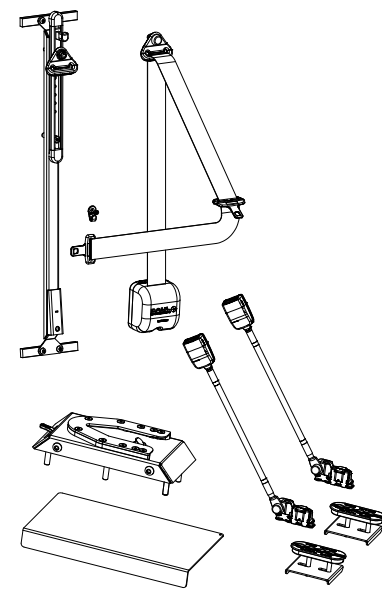
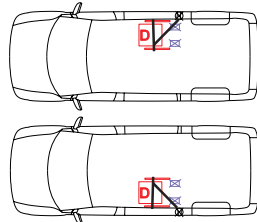

Art. nr. 503144
 VW Crafter 2017-
 MAN TGE 2017-

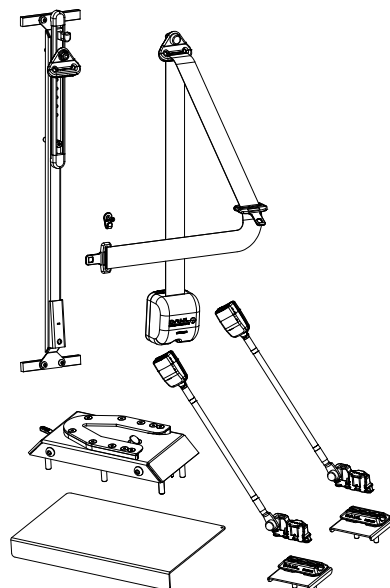
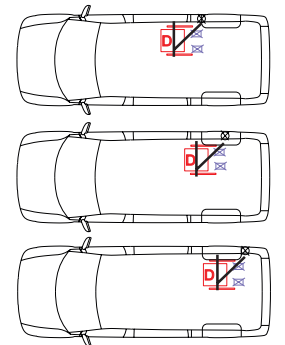

Art. nr. 503145
 VW Crafter 2017-
 MAN TGE 2017-

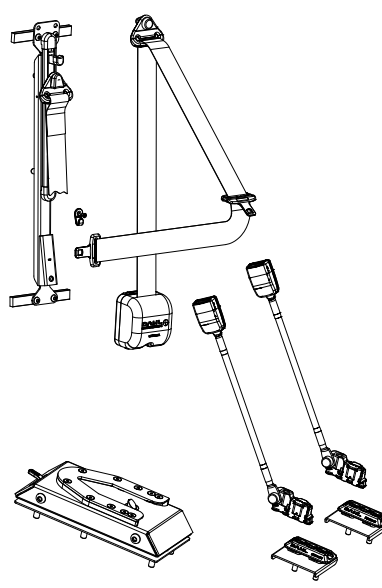
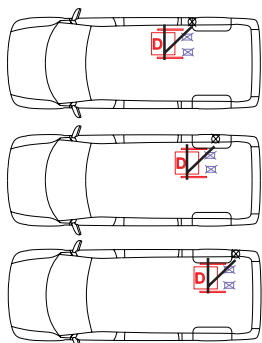

Art. nr. 503197
 Nissan NV 200

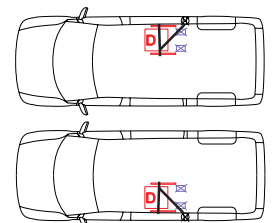

Dahl Docking Station MK II System - godkendte monteringsæt

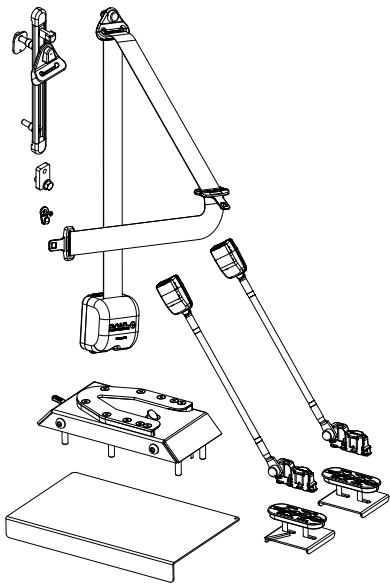

Art. nr. 503301

Citroën Jumpy & Spacetourer KO
Opel Zafira Life
Peugeot Expert & Traveller KO
Toyota Proace & Proace Verso 2016-

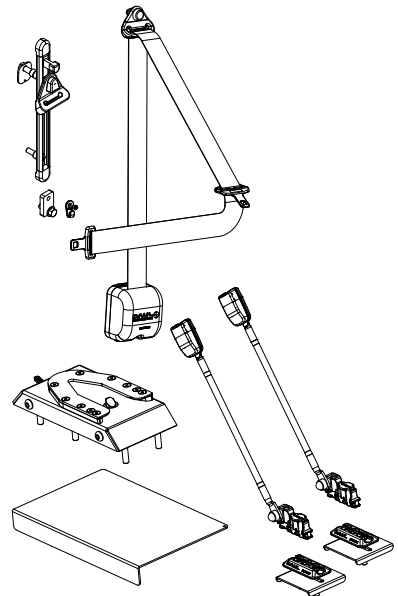
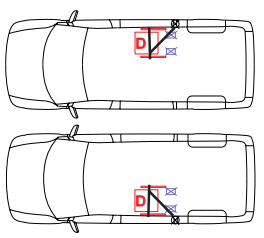

Art. nr. 503302

Citroën Jumpy & Spacetourer KO
Opel Zafira Life
Peugeot Expert & Traveller KO
Toyota Proace & Proace Verso 2016-

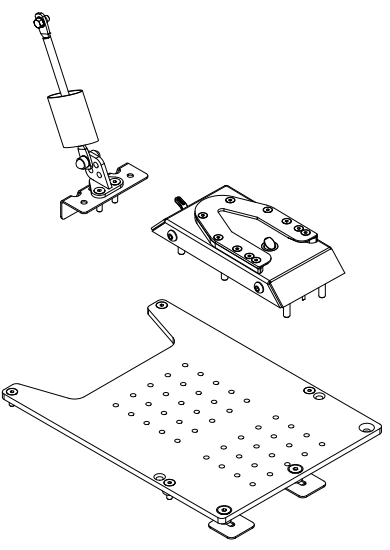
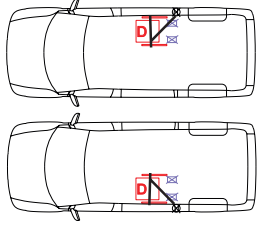

Art. nr. 503303

Citroën Jumpy & Spacetourer KO
Opel Zafira Life
Peugeot Expert & Traveller KO
Toyota Proace & Proace Verso 2016-

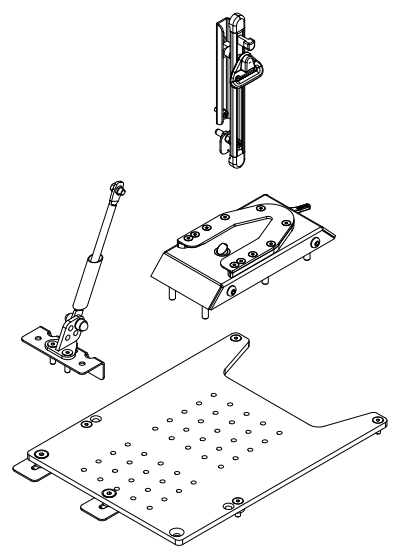
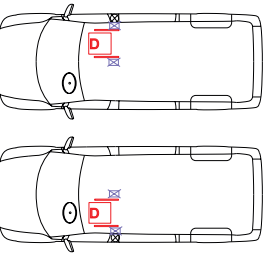

Art. nr. 503304

Citroën Jumpy & Spacetourer KO
Opel Zafira Life
Peugeot Expert & Traveller KO
Toyota Proace & Proace Verso 2016-

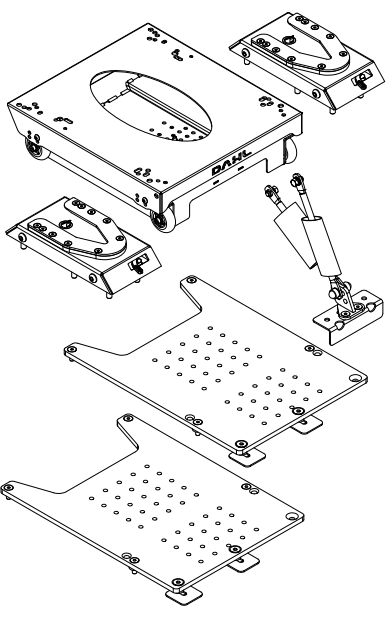
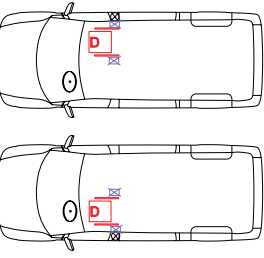

Art. nr. 503305

Citroën Jumpy & Spacetourer KO
Opel Zafira Life
Peugeot Expert & Traveller KO
Toyota Proace & Proace Verso 2016-

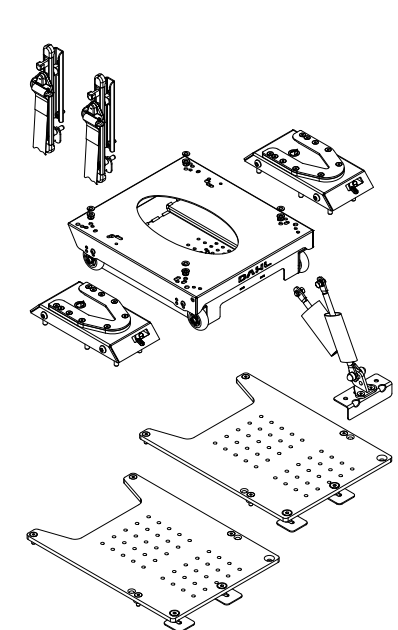
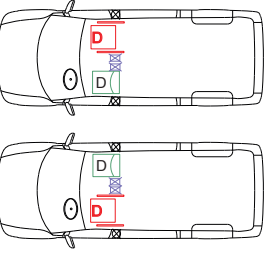

Art. nr. 503306

Citroën Jumpy & Spacetourer KO
Opel Zafira Life
Peugeot Expert & Traveller KO
Toyota Proace & Proace Verso 2016-

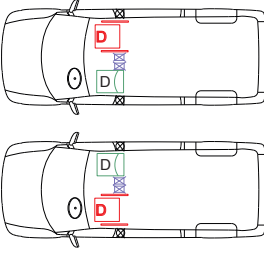

Dahl Docking Station MK II System - godkendte monteringsæt

Art. nr. 503255

ITEK Drop Floor
Conversion:

VW Caddy Active

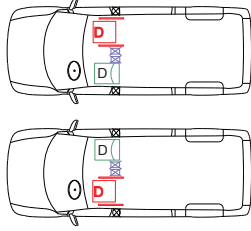
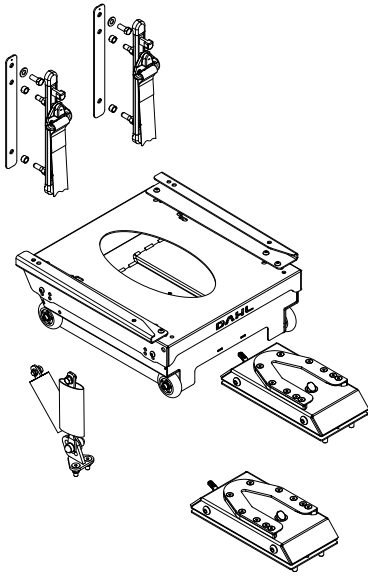

Art. nr. 503310

ITEK Drop Floor
Conversion:

VW Caddy Active

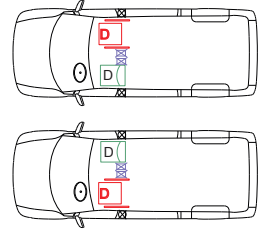
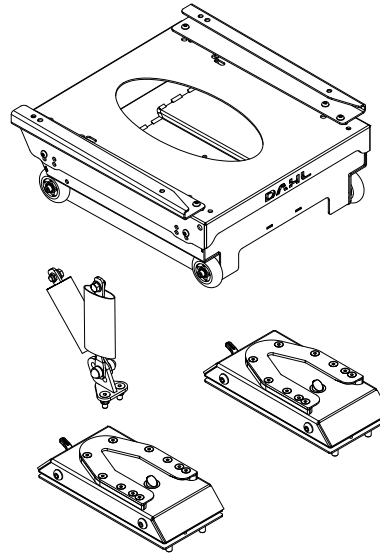

Art. nr. 503461

Tripod/Allied Drop Floor
Conversion:

Citroën Berlingo

Peugeot Partner

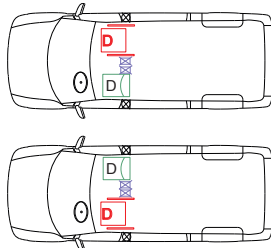
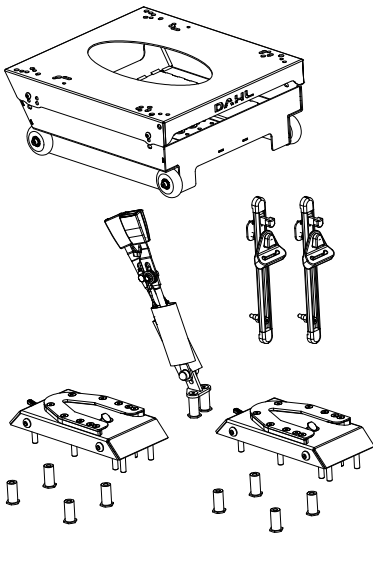

Art. nr. 503006

MB Vito

MB V-Class W447

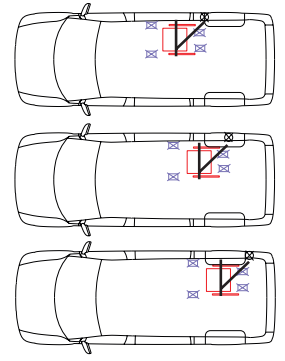
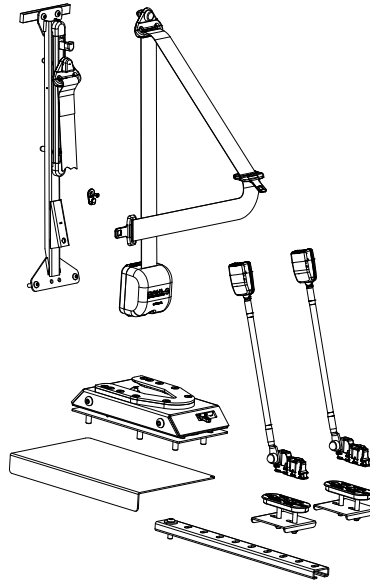

Art. nr. 503008

MB Vito

MB V-Class W447

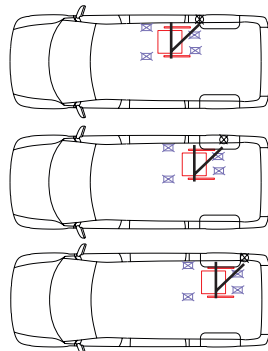
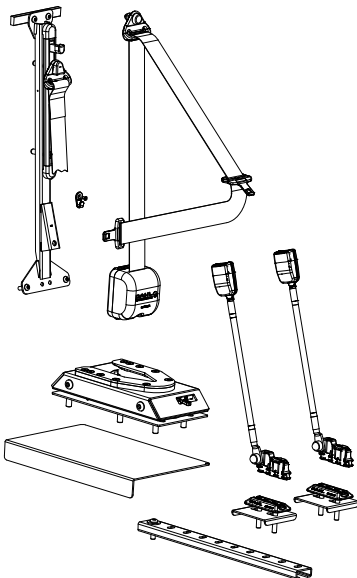

Dahl Docking Systemer



Værktøj til montering af seleforankringsæt

Når man skal indrette et ombygget køretøj med f.eks. et specialsæde, eller indrette det med en plads til en kørestolsbruger, kan det være svært at montere en sikkerhedssele, når man har fjernet det originale sæde. De originale sæder er ofte udstyret med integrerede sikkerhedssele, og når først sæderne tages ud, mistes også de godkendte forankringspunkter til sikkerhedsselelerne.

Derfor har vi udviklet og testet eftermonterbare seleforankringsæt med eksempelvis højdejusteringer til skulderselen, stålwirer, og forstærkningsbeslag til karosseriet. Disse sæt kan anvendes til bilens originale selelås, eller sammen med en komplet 3-punkt sele til en kørestolsbruger fra vores leveringsprogram.



Art. nr. 503510



Art. nr. 503511

Specialværktøj til montering, 7/16" UNF gevind

Specialværktøj til montering, M8 gevind

Eksempler af testede bilmodeller med vores Dahl Docking Systemer



Mercedes Sprinter, VW Crafter



Ford Transit Custom



Mercedes Vito/Viano



VW T5



Opel Vivaro / Renault Trafic



Ford Transit



Nissan NV400, Opel Movano, Renault Master



VW Caddy



Peugeot Partner / Citroën Berlingo



Fiat Ducato / Peugeot Boxer / Citroën Jumper



Citroën Jumpy / Peugeot Expert / Fiat Scudo

Bilsæder



Inden produktet når igennem det berømte nåleøje, har vi under udviklingsarbejdet udført mere end 130 tests i vores eget testlaboratorium i Thisted og i udlandet.

Sædet opfylder foruden ECE 44/04 kravene for barne-stole også ECE's skrappe M1 krav for personbiler og M2 for minibusser i henhold til ECE 14, 16 og 17.

Vores HYBRID og COMFORT Seats er testet i henhold til ECE 14 i følgende bilmodeller:

Citroën Jumpy Y	Mercedes Sprinter	Peugeot Boxer Y
Fiat Ducato X250	906,907&910	Renault Master X62
Ford Transit Custom V362	Mercedes Vito 447	VW Crafter 2006-2016
MAN TGE	Nissan NV400	VW Crafter 2017-
	Opel Movano X62	VW T5 & T6

Vi har også testet vores HYBRID og COMFORT Seats i henhold til FMVSS 207/210, og CMVSS 207/210 i Mercedes Sprinter 907 og 910.

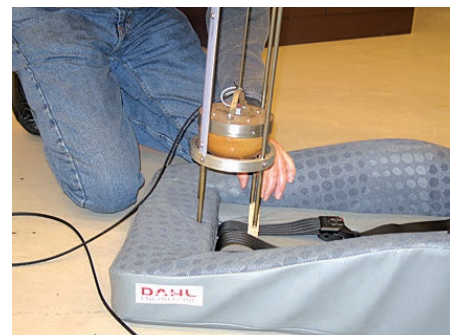

COMFORT SEAT™



COMFORT SEAT™ er, som det eneste sæde med indbygget 3-punkt sele på markedet for minibusser, formgivet med ekstra sidestøtte og polsterfjedre i såvel sædepude som i ryglæn.

Derfor tilbyder COMFORT SEAT™ den samme komfort som personbilsæder. Normalt er sæde og ryglæn i minibusser polstret på metal- eller krydsfinerplader.

COMFORT SEAT™ kan leveres med justerbare armlæn og glideskinner.

Dahl COMFORT Seats - godkendte monteringsæt

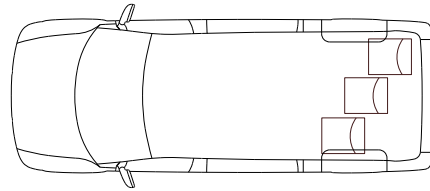
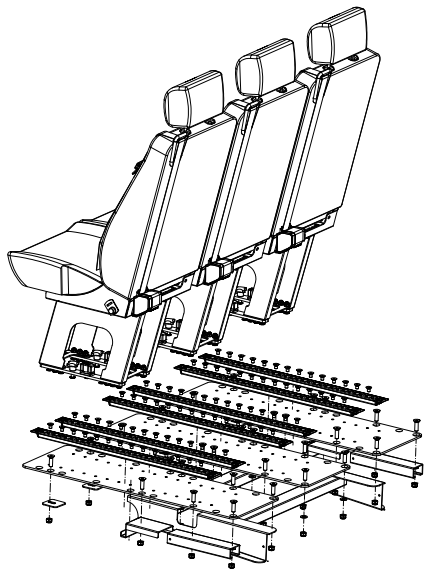

Art. nr. 503380

VW T5 & T6 original floor

GM Coachwork Colorado

VW T5 & T6 drop floor

conversion

Zawatzky centervan

VW T5 & T6 drop floor

conversion

DAHL COMFORT SEAT

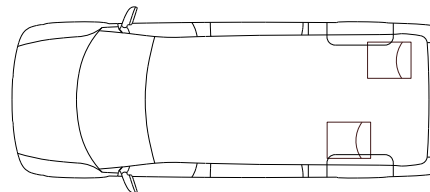
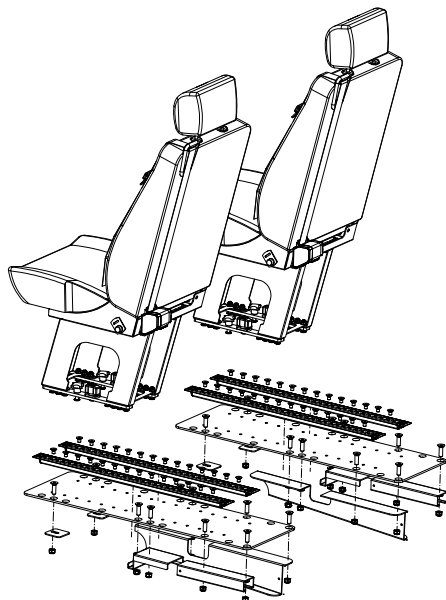

Art. nr. 503381

VW T5 & T6 original floor

GM Coachwork Colorado

VW T5 & T6 drop floor

conversion

Zawatzky centervan

VW T5 & T6 drop floor

conversion

DAHL COMFORT SEAT

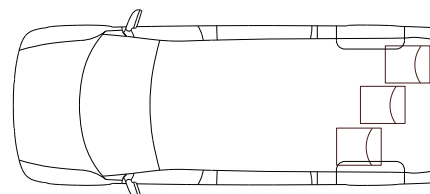
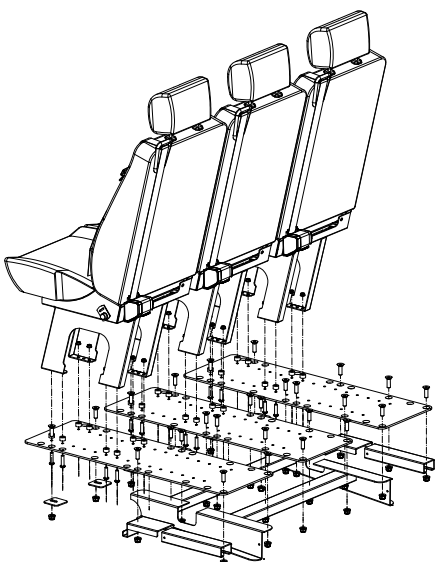

Art. nr. 503382

VW T5 & T6 original floor

GM Coachwork Colorado

VW T5 & T6 drop floor

conversion







Zawatzky centervan

VW T5 & T6 drop floor

conversion

DAHL COMFORT SEAT

Gulvskinner og forstærkninger

<p>Sædeforankringsplader</p>  <p>Art. nr. 500093 620 mm Art. nr. 500083 747 mm Art. nr. 500089 935 mm Art. nr. 500090 1497 mm Art. nr. 500110 1995 mm Art. nr. 500092 2495 mm Art. nr. 500109 2995 mm</p>	<p>Art. nr. 500911 Forstærkningstravers, 2495 mm</p> 	<p>Art. nr. 500777 Dahl HEAVY DUTY gulvskinne, 3230mm</p> 
	<p>Art. nr. 500780 Endebeslag til Dahl HEAVY DUTY gulvskinne art. nr. 500777</p> 	<p>Art. nr. 502138 Forstærkningsprofil 2487 mm</p> 
	<p>Art.nr. 502162 DAHL HEAVY DUTY Gulvskinne, undersænket montering, 3230mm</p> 	<p>Art. nr. 502228 Endebeslag til DAHL HEAVY DUTY gulvskinne (undersænket) art. nr. 502162.</p> 

DAHL HYBRID SEAT™



DAHL HYBRID SEAT™ med indbygget barnestol kan kendes på det diskrete broderi i ryglænet.



Med DAHL HYBRID SEAT™ monteret i en minibus kan vognmanden i løbet af dagen tilbyde sikker og fleksibel transport til skoler, børnehaver, plejehjem og institutioner med mere i vilkårlig rækkefølge. Chaufførerne slipper for at skulle bruge tid på at køre hjem for at hente og montere barnestole, og for at afmontere og aflevere igen efter brug. Det sparer tid og redder liv.

Den almindelige 3-punkt sele er ikke nok!

Crash-tests viser at et barn der spændes fast med en almindelig sikkerhedssele til en voksen, eller spændes fast i en barnestol der ikke passer til barnet størrelse risikerer:

- at blive slynget ud af selen og kastet voldsomt rundt i køretøjet, under en kollision eller,
- at glide under sikkerhedssele, hvorved den kommer til at presse voldsomt på barnets sårbare mave- og brystregion.

Ved begge scenarier kan barnet i værste fald pådrage sig invaliderende eller livstruende kvæstelser.

Skærpede krav til fastspænding af børn i biler

Derfor blev der i 2006 indført skærpede regler for fastspænding af børn i personbiler. Reglerne siger, at børn skal være spændt fast i ECE 44 godkendte barnestole, der passer til børnenes vægt og højde. Overtrædelse straffes med bøde og et klip i kørekortet.

For taxaer og busser til erhvervmæssig befordring, har det vist sig at være en større udfordring at transportere og håndtere de mange løse barnestole. Det har hidtil ikke været praktisk muligt at køre rundt med barnestole til for eksempel 15 børn.

Det er for tidskrævende at skulle flytte rundt, og montere barnestolene hver gang der er behov for det. Desuden giver det store pladsproblemer at opbevare barnestolene i køretøjet, når de ikke er i brug. Resultatet er, at børnene enten ikke spændes fast eller at de fastspændes med sikkerhedssele til voksne, som tests har vist ikke yder en effektiv beskyttelse under et uheld.

Men nu findes der en løsning.



Tests viser, at det kan medføre invaliderende eller livstruende kvæstelser, hvis et barn spændes fast med en almindelig 3-punkt sikkerhedssele til voksne. Barnet risikerer, som ved denne test – at glide under selen, hvorved den presser med flere hundrede kilo på mave og brystregion.

DAHL HYBRID SEAT™



Sædet løser på en gang tre praktiske problemer med hensyn til sikkerhed, plads og tidsforbrug. På 3 sekunder kan hybridsædet forvandles fra en barnestol til et sæde til en voksen passager, eller omvendt. Som de første og eneste på markedet, kan Dahl Engineering tilbyde ECE 44/04 godkendte sæder der er aftagelige og flytbare, og som har integrerede barnestole til alle siddepladser i en minibus.

Patenteret sæde med integreret barnestol løser problemet

I stedet for at bruge køretøjets sikkerhedsseler, som er beregnet til voksne eller køre rundt med løse barnestole har Dahl Engineering udviklet et hybridsæde - DAHL HYBRID SEAT™, som kan benyttes af alle børn fra ni måneder og af voksne.

Sædet er patenteret og bygger på en ultrakompakt konstruktion, som har gjort det muligt at indbygge en barnestol i et sæde konstrueret til en voksen. Hybridsædet kan gøre almindelige løse barnestole i minibusser o.l. overflødige og kan i løbet af 3 sekunder forvandles fra et normalt sæde til voksne til en ECE 44/04 godkendt barnestol til børn.

DAHL HYBRID SEAT™ sparer tid og redder liv

Med DAHL HYBRID SEAT™ monteret i eksempelvis en minibus, kan vognmanden i løbet af dagen tilbyde sikker og fleksibel transport til skoler, børnehaver, plejehjem og institutioner m.m. i vilkårlig rækkefølge, og uden at skulle bruge tid på at køre hjem for at hente og aflevere barnestole - for derefter igen at skulle montere og afmontere dem.

Det nye sæde passer til et nyudviklet, kraftigt skinnesystem, som kan monteres i minibussen, så sædet kan flyttes rundt i bilen eller tages helt ud, hvis der skal være plads til eksempelvis en kørestol.

Det nye sæde løser mindst tre praktiske problemer, når det gælder transport af børn i minibusser:

1. Det sikkerhedsmæssige aspekt forbundet med ukorrekt fastspænding af børn.
2. Hvor man skal gøre af barnestolene, når de ikke er i brug.
3. Det forholdsmæssigt store tidsforbrug, som er forbundet med at montere og afmontere en barnestol.

Multisæde - 4 i én

Hybridsædet opfylder sikkerhedskravene til sæder for voksne samt til børn i tre ECE 44/04 grupper

DAHL HYBRID SEAT™ opfylder EUs strengeste krav for sæder i personbiler (M1). Derudover lever sædet også op til ECE regulativ 44/04 for barnestole i gruppe 1, 2 og 3*.

Med andre ord kan man med Hybrid-sædet fastspænde børn fra en alder på ca. 9 måneder og op til en størrelse, hvor de ikke længere behøver at være spændt fast i en barnestol under kørsel.

DAHL HYBRID SEAT™ har indbygget en 3-punkt sele til voksne og de større børn, og en 5-punkt H-sele til de mindste.

*ECE 44/04 gruppeinddeling af børn:

Gruppe 1:	fra	9 - 18 kg
Gruppe 2:	fra	15 - 25 kg
Gruppe 3:	fra	22 - 36 kg

Med 5-punkt H-sele



Børn i gruppe 1 og 2 spændes fast med den indbyggede 5-punkt H-sele



Justerspændet sikrer, at H-selen enkelt og hurtigt kan indstilles optimalt efter barnets højde



Selelås til 5-punkt H-sele

Med 3-punkt sele

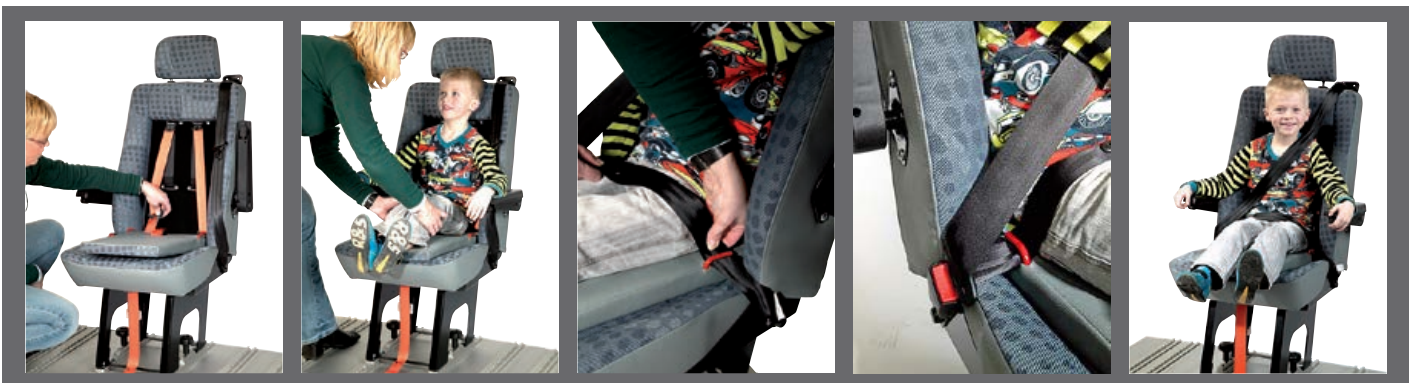

Børn i gruppe 3 spændes fast med den indbyggede 3-punkt sele. Selestroppen føres under de røde kroge på hver side af barnets hofte

Tilbehør til HYBRID SEAT og COMFORT SEAT

Ben til fastmontering af
Dahl Sæder

Art.nr.	Højde
501560	270 mm
501561	300 mm
501562	325 mm
501563	350 mm



Ben til skinnemontering
af Dahl Sæder

Art. nr.	Højde
501564	270 mm
501565	300 mm
501566	325 mm
501567	350 mm



OBS:
På grund af skinnemontering, bliver samlet højde 10mm højere.

Forespørg venligst, hvilken benhøjde er godkendt til den specifikke bilmodel.



Art. nr. 500602
Betræk til COMFORT Seat,
spørg efter tilgængelige modeller



Art.nr. 503545
Understel til forankring af Dahl COMFORT Seat med VarioDock™,
fra 2. sæderække og bagud



Art. nr. 500925
Glideskinner med
160 mm længdejustering



Art. nr. 501325
Dahl lockable skinnefitting til
Dahl Heavy Duty skinne

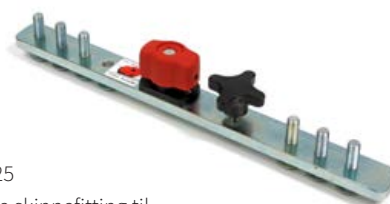

Art. nr. 500076
Justerbart armlæn – højre



Art. nr. 500077
Justerbart armlæn – venstre



Dahl Low floor System

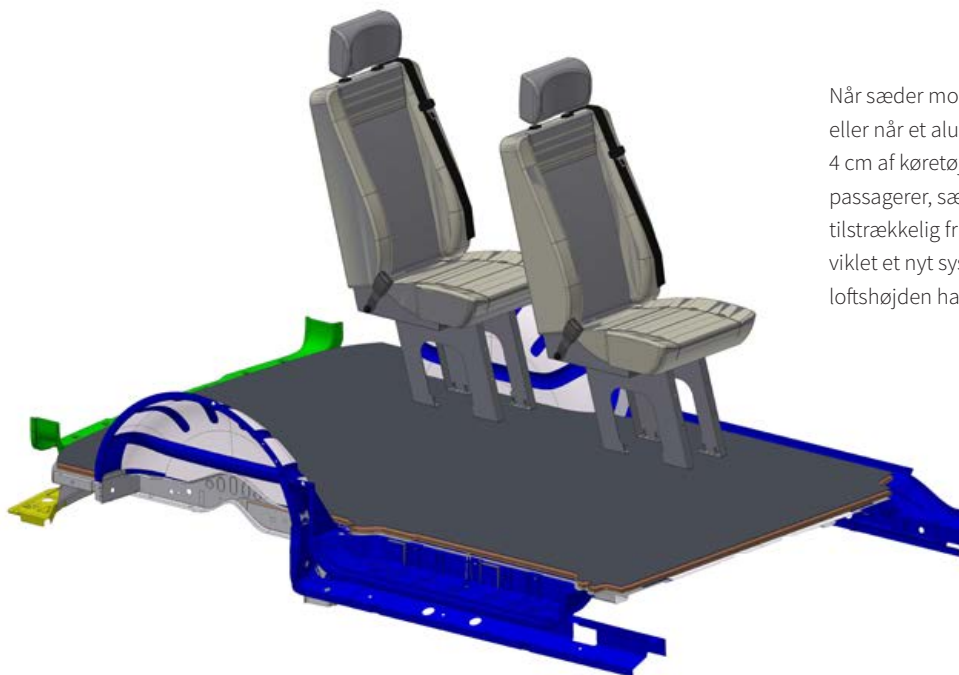

Når sæder monteres på traditionel vis med forstærkningsprofiler, eller når et alu-gulv placeres ovenpå selve vognbunden, går cirka 4 cm af køretøjets indvendige frihøjde til spilde. Det betyder at passagerer, særligt kørestolsbrugere, i nogle køretøjer ikke har tilstrækkelig frihøjde til hovedet. Dahl Engineering har derfor udviklet et nyt system til forankring af sæder i køretøjer, hvor især loftshøjden har betydning for køretøjets anvendelighed.

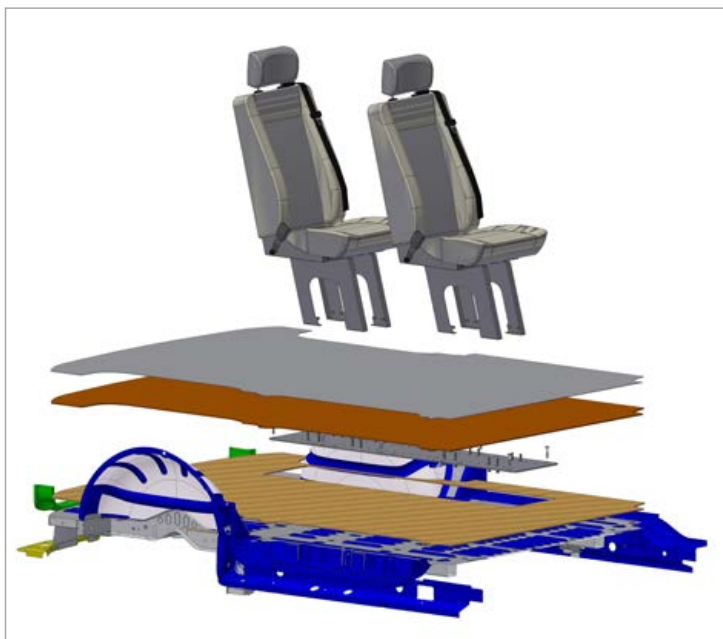

Low floor systemet er illustreret med en VW Transporter/Cara-velle T5 og T6 vognbund, men tilbydes også til Mercedes Vito/Viano 639, Citroën Jumper, Fiat Ducato, Peugeot Boxer og Ford Transit. Flere er pt. under udvikling.

Det meget enkle monteringsprincip virker ved at sæderne fastboltes til sædeforankringsplader i højstyrkestål, der herefter monteres fast til køretøjet ved hjælp af særligt tilpassede forstærkningsdele under vognbunden. Forankringspladerne undersænkes i en tynd krydsfinerplade i et på forhånd udskåret hul. Ovenpå placeres endnu en krydsfinerplade med gulvbelægning og præborede huller til boltene, hvor sæderne slutteligt boltes fast.

Fastgørelse af sæde på forankringsplade

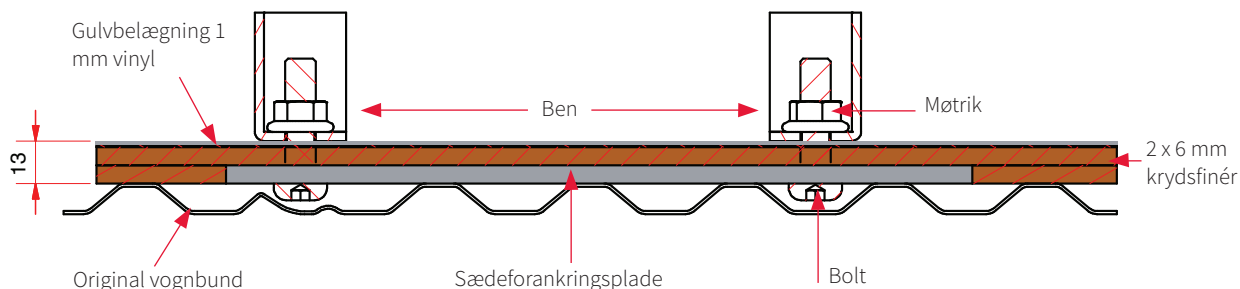

Dahl Low Floor System kan øge frihøjden med helt op til 25-30 mm i forhold til traditionelle forstærkningsprofiler og alu-gulve, der monteres ovenpå vognbunden.

Dahl Low floor System

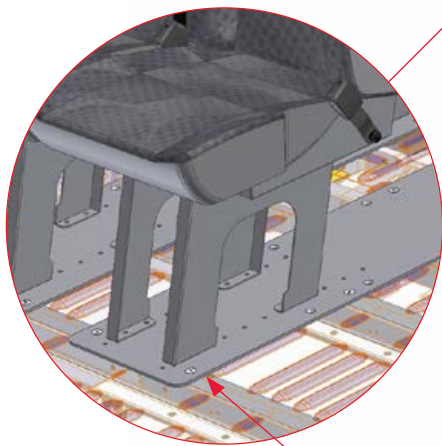

Monteringsprincippet er illustreret uden finerbunden monteret.

Forankringspladen fastgøres med bolte igennem vognbunden.

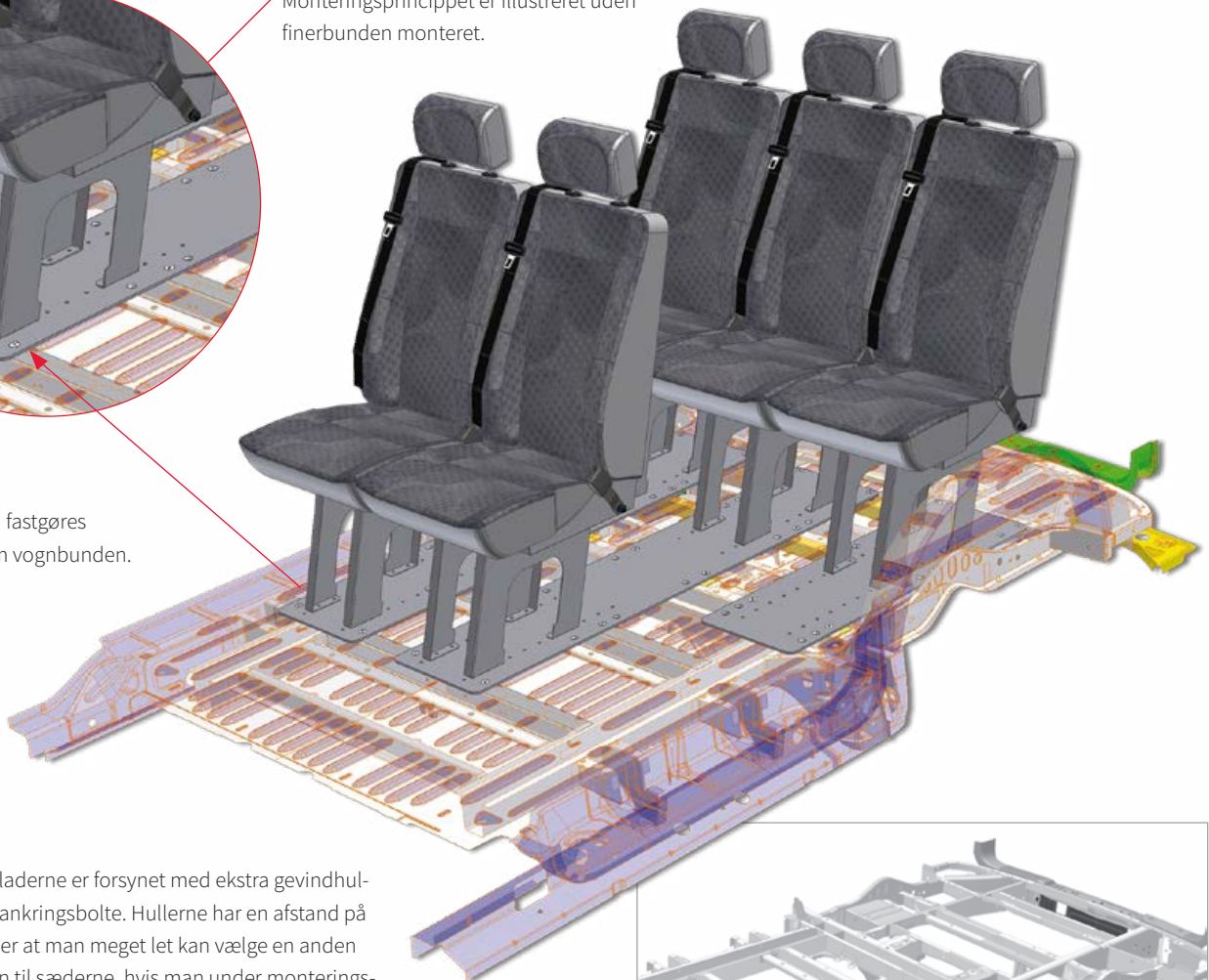

Selve forankringspladerne er forsynet med ekstra gevindhuller til sædernes forankringsbolte. Hullerne har en afstand på 5 cm, hvilket betyder at man meget let kan vælge en anden monteringsposition til sæderne, hvis man under monteringsarbejdet eksempelvis finder ud af, at et sæde skal monteres anderledes for at være placeret optimalt.

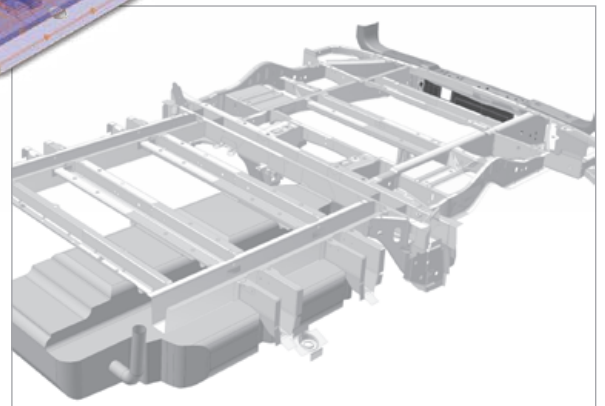

Forstærkningsdelene er tilpasset det enkelte monteringssted – også omkring brændstoftanken.

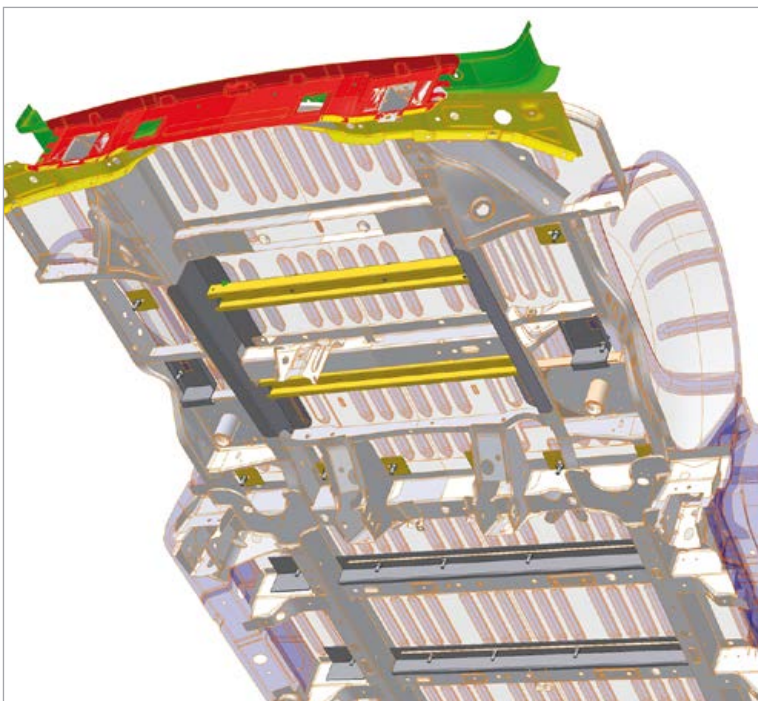

Ved montering af DAHL Low Floor forankringsplader, bliver det, modsat ved montering af traditionelle forstærkningsprofiler, muligt at arbejde med en boreskabelon med faste positioner til hullerne i vognbunden. Samtidigt kan man stadig vælge mellem forskellige positioner til sæderne, selvom hullerne på forhånd er boret i vognbunden. Monteringsarbejdet bliver herved meget mere enkelt, eftersom tidsforbrug og risiko for fejl reduceres væsentligt, eksempelvis i forbindelse med eftersvejsning af fejlborede huller.

Dahl Low floor System

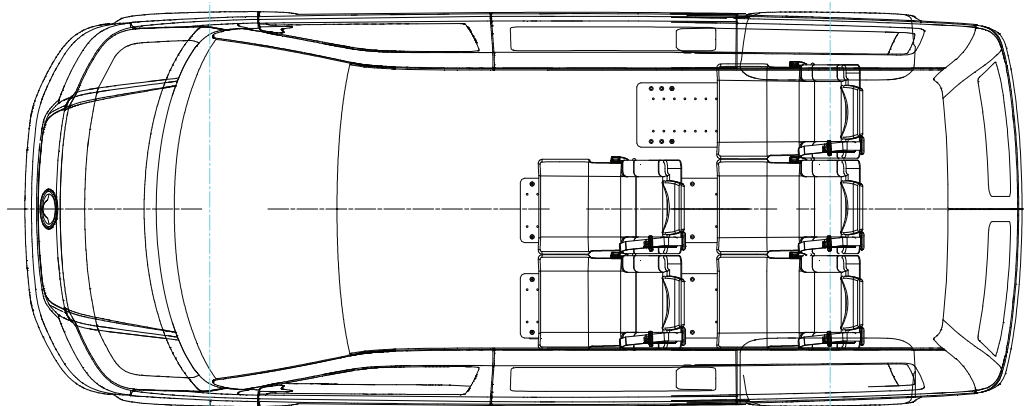

Bestolings eksempel i VW Transporter/Caravelle T5 og T6
– hjulafstand 3000 mm

Low floor med
skinnemontering

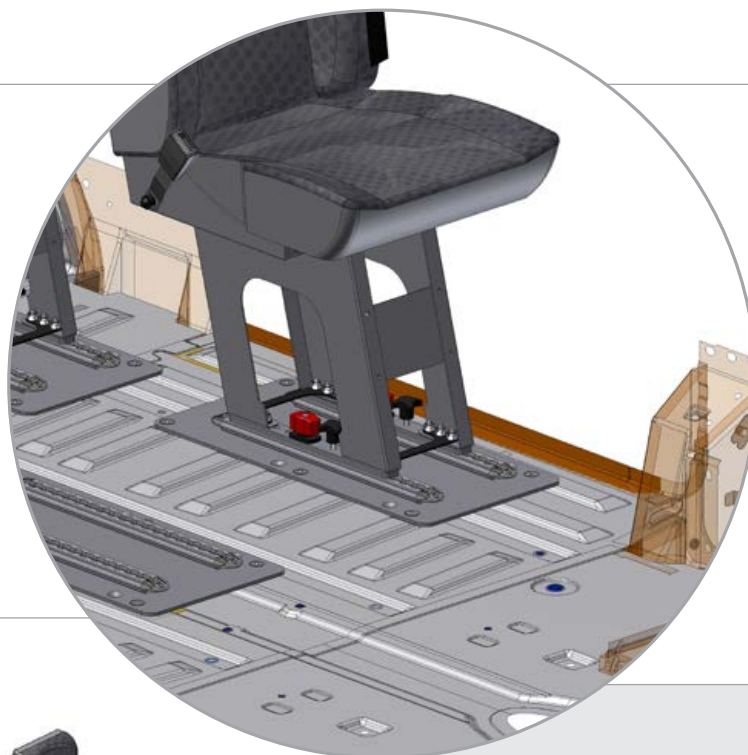

Low floor med
fastmonterede sæder

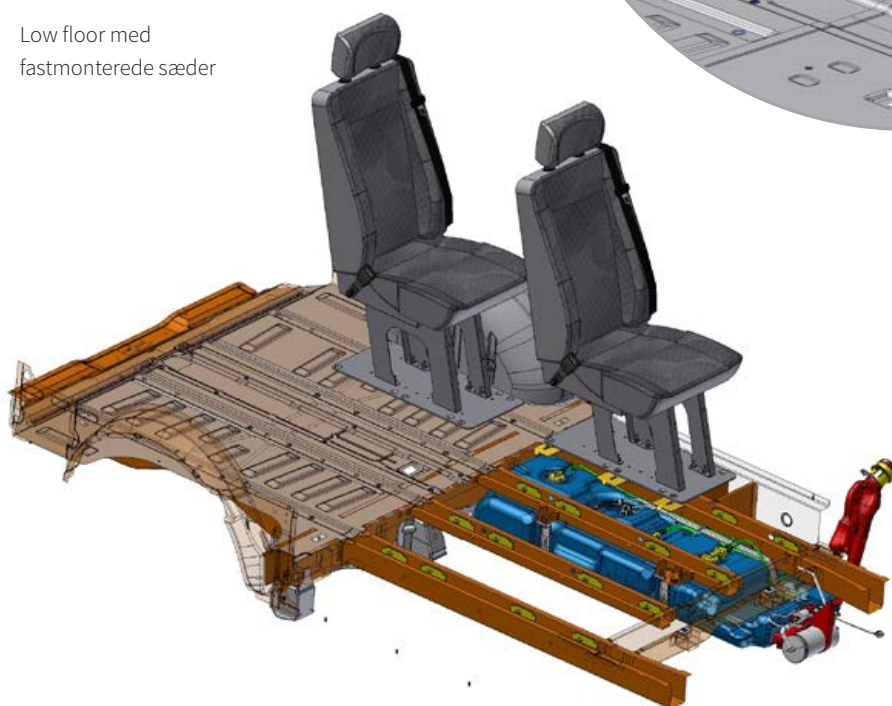

På nuværende tidspunkt foreligger TÜV-godkendelse til de følgende bilmodeller: Citroën Jumper Y, Fiat Ducato X250, Fiat TALENTO, Ford Transit Custom V362, Mercedes Sprinter 906/907/910, Nissan NV300, Nissan NV 400, Opel Movano X62, Opel Vivaro X83/X82, Peugeot Boxer Y, Renault Master X62, Renault Trafic X83/X82, Mercedes Vito W639 & W447, VW Crafter (2006-2016), VW Crafter 2017-VW T5 og T6

Flere testes løbende. Spørg os derfor venligst om det aktuelle leveringsprogram.

4-punkt kørestolsfastspændinger

4-punkt retraktorsystem med automatisk 3-punkt sele

Med vores 3-punktssikkerhedssele, er det meget hurtigere og mere enkelt at fastspænde kørestolsbrugeren end med traditionelle 3-punkt sikkerhedsseleer.

Med en 178 mm højdejustering til skulderselelen, kan selet indstilles for optimal komfort og sikkerhed for små og store passagerer.

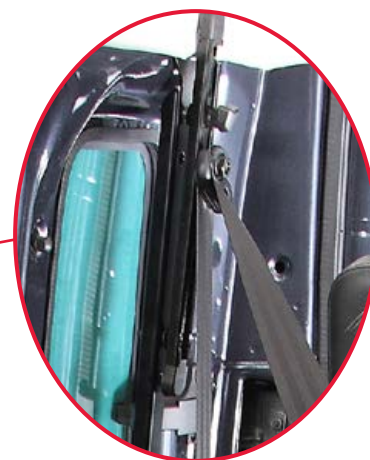

Sikkerhedsselelåsene er monteret på de bageste fastspændingsretraktorer, og den automatiske 3-punkt sikkerhedssele fastgøres hurtigt og let til selelåsene, som er ført op i en bekvem højde lige bag kørestolen.

4-punkt kørestolsfastspændinger

EVOLUTION Line - op til 85 kg

EVOLUTION Line er en videreudvikling med fokus på flot design, holdbarhed og lav vægt uden på nogen måde at gå på kompromis med kvalitet og robusthed. Ved anvendelse af nye og bedre materialer er det lykkedes at reducere vægten med 27 % i forhold til en tilsvarende CLASSIC Line retraktor, mens den matcher eller overgår CLASSIC Lines kvalitetsparametre, hvilket særligt værdsættes i køretøjer, hvor vægten er meget kritisk.

- Hus til retraktor er støbt i brudsikkert kunststof med flot mat finish
- Brudsikkerhed testet ved temperaturer ned til -21° C
- Robust håndhjul i metal på siden til opstramning af stroppen
- Lav vægt
- Trykknop til at løsne stroppen



CLASSIC Line - op til 85 kg

CLASSIC Line er vores første generation fastspændingsretraktor, som er kendetegnet ved et flot design og høj kvalitet.

- Hus til retraktor er støbt i metal
- Flot sølv metallic overfladebehandling
- Håndhjul i begge sider til opstramning af stroppen
- Trykknop til at løsne stroppen

4-punkt kørestolsfastspændinger

HEAVY DUTY Line

– til kørestole på op til 200 kg plus bruger

Da moderne el-kørestole oftest vejer langt mere end de 85 kg, som de nuværende regler for fastbindingsudstyr foreskriver, har Dahl Engineering som de første i verden udviklet TÜV godkendte Heavy Duty fastspændingssystemer med tilhørende køretøjsspecifikke monteringsæt, som lever op til og overgår EU forordning 2018/858. Disse patentanmeldte sæt kan anvendes til kørestole med en vægt på henholdsvis 170 kg og 200 kg plus bruger.

- Fastspændingssystem med køretøjsspecifikke monteringsæt
- Sæt testet til konkrete bilmodeller og montagepositioner
- Dynamisk crash-testet med 48 km/h som komplet sæt (retraktor, sele, gulvbeslag, højdejustering)
- Nyudviklet gulvbeslag
- TÜV Rapporter og dokumentation til alle køretøjsspecifikke monteringsæt tilgængelig
- Alle HEAVY DUTY-sæt er med EVOLUTION retraktorer
- Patentanmeldt



HEAVY DUTY System til kørestole op til 170 Kg + bruger



HEAVY DUTY System til kørestole op til 200 Kg + bruger

Vores fastspændingsretraktorer findes i forskellige varianter. Venligst se listen med testede køretøjer til vores 4-punkt WTORS sæt på de følgende sider.

Systemer som er i stand til at modstå kørestole med en vægt på mere end standardsæts (85 kg) er mærket med kørestolens max. vægt.

Ved hvert sæt oplyses om godkendte bilmodeller samt en skitse, som angiver godkendte monteringspositioner:

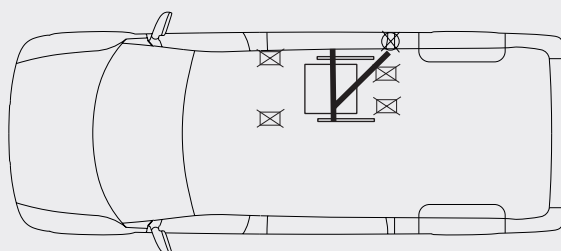

4-punkt kørestolsfastspændinger – godkendte monteringsæt

Bil-mærke	Bilmodel	Position af skuldersele-forankring	Gulvbeslag type	Op til 85kg - CLASSIC Line	Op til 85 kg - EVOLUTION Line	Op til 170kg - HEAVY DUTY Line	Op til 200kg - HEAVY DUTY Line
Citroën	Berlingo Tripod/Allied Floor Conversion	RD			503463	503462	503464
	Jumper Y	C	surface	502057	503170	503136	503135
		C	flush	502058	503171	503497	503488
		W	surface	501945	503483		
		W	flush	501944	502111		
	right side	RD	surface		503736	503623	503604
	right side	RD	flush		503738	503603	503624
	left side	RD	surface		503739	503602	503625
	left side	RD	flush		503737	503622	503605
	Jumpy X	C	surface	502057	503170		
		C	flush	502058	503171		
		W	surface	501949	501057		
		W	flush	501948	501055		
		RD	surface	501771	503293		
		RD	flush	501799	503294		
	Space Tourer/Jumpy KO 2017-	C	surface		503296	503473	503472
		C	flush		503295	503475	503474
		RD	surface	501771	503293	503297	503299
		RD	flush	501799	503294	503298	503300
	Space Tourer/Jumpy KO 2017- Freedom Drop Floor Conversion	C (roof)	surface			503664	
Fiat	Doblo High roof SWB&LWB	D	rail	502311	503312		
		D	rail	502317	501869		
		D	surface		502373	503480	503560
		D	flush		502372	503561	503562
	Ducato X250	C	surface	502057	503170	503136	503135
		C	flush	502058	503171	503497	503488
		W	surface	501945	503483		
		W	flush	501944	502111		
	right side	RD	surface		503736	503623	503604
	right side	RD	flush		503738	503603	503624
	left side	RD	surface		503739	503602	503625
	left side	RD	flush		503737	503622	503605
	Scudo X270	C	surface	502057	503170		
		C	flush	502058	503171		
		W	surface	501949	501057		
		W	flush	501948	501055		
		RD	surface	501771	503293		
		RD	flush	501799	503294		
	Talento	C	surface	502057	503170	503136	503135
		C	flush	502058	503171	503497	503488
	D	surface	502057	503170	503136	503135	
	D	flush	502058	503171	503497	503488	
Ford	Transit Custom V362	C	surface	502057	503170		
		C	flush	502058	503171		
		W	surface	501947	503486	503136	503135
		W	flush	501946	503487	503497	503488
		D	surface	502057	503170	503136	503135
		D	flush	502058	503171	503497	503488
		RD	surface	501771	503293		
		RD	flush	501799	503294		
	Transit V363	C	surface	502056	501054		
		C	flush	502055	501053		
		W	surface	502060	501051		
		W	flush	502059	501050		
		D	surface	502057	503170		
		D	flush	502058	503171		
MAN	TGE 2017-	C	surface	503162	503133	503490	503496
		C	flush	503163	503131	503489	503493
		W	surface	503164	503132	503491	503494
		W	flush	503163	503130	503492	503495
		D	surface	502057	503170	503136	503135
		D	flush	502058	503171	503497	503488
		RD	surface		500114	500116	500118
	RD	flush		500115	500117	500119	
Mercedes	Sprinter 906 & 907 & 910	C	surface	502057	503170	503136	503135
		C	flush	502058	503171	503497	503488
		W	surface	501679	503482		500826
		W	flush	501932	503484		500827
		D	surface	502057	503170	503136	503135
		D	flush	502058	503171	503497	503488
		RD	surface		500114	500116	500118
	RD	flush		500115	500117	500119	

SYMBOLER: C = C stolpe / D = D stolpe / W = vinduesramme / RD = bagdør / Gulvbeslag : surface = oven på gulv / flush = undersænkning / Rail = gulvskinne

4-punkt kørestolsfastspændinger – godkendte monteringsæt

Bil-mærke	Bilmodel	Position af skuldersele-forankring	Gulvbeslag type	Op til 85kg - CLASSIC Line	Op til 85 kg - EVOLUTION Line	Op til 170kg - HEAVY DUTY Line	Op til 200kg - HEAVY DUTY Line
Mercedes	Sprinter 906 & 907 High roof, wheel base 3250-3665-4325	W	surface	502063	500726		
		W	flush	502062	500729		
	Vito & V-Class W447	W	surface	502241	503485		
		W	flush	502239	503524		
		RD	surface	501771	503293		
		RD	flush	501799	503294		
	Vito 639 & V-Class W447	C	surface	502057	503170	503136	503135
		C	flush	502058	503171	503497	503488
		W	surface	501821	501789		
		RD	surface	501771	503293	503297	503299
Nissan		RD	flush	501799	503294	503298	503300
		RD	surface		503358		
		RD	flush		503357		
	Nissan NV 200	W	surface	501947	503486		
		W	flush	501946	503487		
		RD	surface		503187		
	Nissan NV 300	C	surface	502057	503170	503136	503135
		C	flush	502058	503171	503497	503488
		D	surface	502057	503170	503136	503135
		D	flush	502058	503171	503497	503488
	Nissan NV400	C	surface	502057	503170	503136	503135
		C	flush	502058	503171	503497	503488
		W	surface	501942	501885		
		W	flush	501943	501886		
	D	surface	502057	503170	503136	503135	
	D	flush	502058	503171	503497	503488	
Nissan Primastar	C	surface	502057	503170			
	C	flush	502058	503171			
	D	surface	502057	503170			
	D	flush	502058	503171			
Opel	Combo High roof SWB&LWB	D	surface		502373	503480	503560
		D	flush		502372	503561	503562
		D	rail	502311	503312		
		D	rail	502317	501869		
	Movano X62	W	surface	501942	501885		
		W	flush	501943	501886		
		C	surface	502057	503170	503136	503135
		C	flush	502058	503171	503497	503488
		D	surface	502057	503170	503136	503135
		D	flush	502058	503171	503497	503488
	Vivaro X82	C	surface	502057	503170	503136	503135
		C	flush	502058	503171	503497	503488
		D	surface	502057	503170	503136	503135
		D	flush	502058	503171	503497	503488
	Vivaro X83	C	surface	502057	503170	503136	503135
		C	flush	502058	503171	503497	503488
		D	surface	502057	503170	503136	503135
		D	flush	502058	503171	503497	503488
	Zafira Life	C	surface		503296	503473	503472
		C	flush		503295	503475	503474
	RD	surface	501771	503293	503297	503299	
	RD	flush	501799	503294	503298	503300	
Zafira Life - Freedom drop floor conversion	C (roof)	surface			503664		
Boxer Y	C	surface	502057	503170	503136	503135	
	C	flush	502058	503171	503497	503488	
	W	surface	501945	503483			
	W	flush	501944	502111			
right side	RD	surface		503736	503623	503604	
right side	RD	flush		503738	503603	503624	
left side	RD	surface		503739	503602	503625	
left side	RD	flush		503737	503622	503605	
Expert X	C	surface	502057	503170			
	C	flush	502058	503171			
	W	surface	501949	501057			
	W	flush	501948	501055			
	RD	surface	501771	503293			
	RD	flush	501799	503294			
Partner Tripod/Allied floor conversion	D	surface		503463	503462	503464	
Traveller/Expert KO 2017-	C	surface		503296	503473	503472	
	C	flush		503295	503475	503474	
	RD	surface	501771	503293	503297	503299	
	RD	flush	501799	503294	503298	503300	
Traveller/Expert KO 2017- Freedom Drop Floor Conversion	C (roof)	surface			503664		

4-punkt kørestolsfastspændinger – godkendte monteringsæt

Bil-mærke	Bilmodel	Position af skulderseleforankring	Gulvbeslag type	Op til 85kg - CLASSIC Line	Op til 85 kg - EVOLUTION Line	Op til 170kg - HEAVY DUTY Line	Op til 200kg - HEAVY DUTY Line	
Renault	Master X62	C	surface	502057	503170	503136	503135	
		C	flush	502058	503171	503497	503488	
		W	surface	501942	501885			
		W	flush	501943	501886			
		D	surface	502057	503170	503136	503135	
		D	flush	502058	503171	503497	503488	
	Trafic X82	C	surface	502057	503170	503136	503135	
		C	flush	502058	503171	503497	503488	
		D	surface	502057	503170	503136	503135	
		D	flush	502058	503171	503497	503488	
	Trafic X83	C	surface	502057	503170	503136	503135	
		C	flush	502058	503171	503497	503488	
D		surface	502057	503170	503136	503135		
D		flush	502058	503171	503497	503488		
Toyota	Proace	C	surface	502057	503170			
		C	flush	502058	503171			
		W	surface	501949	501057			
		W	flush	501948	501055			
	ProAce/Verso 2017-	RD	surface	501771	503293			
		RD	flush	501799	503294			
		C	surface		503296	503473	503472	
		C	flush		503295	503475	503474	
	ProAce/Verso 2017- Freedom Drop Floor Conversion	RD	surface	501771	503293	503297	503299	
		RD	flush	501799	503294	503298	503300	
		C (roof)	surface			503664		
VW	Caddy, ITEK drop floor conversion	RD	surface		503239			
		W	surface	501679	503482		500826	
	Crafter (2006-2016)	W	flush	501932	500814		500827	
		D	surface	502057	503170			
		D	flush	502058	503171			
		RD	surface		500114	500116	500118	
		RD	flush		500115	500117	500119	
	Crafter (2006-2016) High Roof, Wheel base 3250-3665-4325	W	surface	502063	500726			
		W	flush	502062	500729			
	Crafter 2017-	C	surface	503162	503133	503490	503496	
		C	flush	503163	503131	503489	503493	
		W	surface	503164	503132	503491	503494	
		W	flush	503165	503130	503492	503495	
		D	surface	502057	503170	503136	503135	
		D	flush	502058	503171	503497	503488	
		RD	surface		500114	500116	500118	
		RD	flush		500115	500117	500119	
		T5 & T6	C	surface	502057	503170	503136	503135
			C	flush	502058	503171	503497	503488
W	surface		501774	501772				
W	flush		501786	501773				
	D	surface		503170	503136	503135		
	D	flush		503171	503497	503488		
	RD	surface	501771	503293	503297	503299		
	RD	flush	501799	503294	503298	503300		
	RD	surface		503352				
	RD	flush		503353				
T5 & T6 Multivan, original floor rails	RD	surface		503122	503499	503498		
T5 & T6 Colorado, GM Coachwork drop floor conversion	C	surface	502289	503476	503478	503479		
	C	flush	502290	503477				

SYMBOLFORKLARING TIL SÆT MED 4 PUNKT WTORS

Gulvbeslag til montering oven på vognbunden

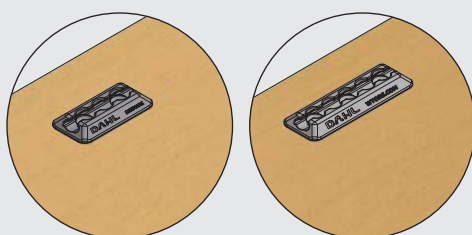

Gulvbeslag til montering nedfældet i vognbunden

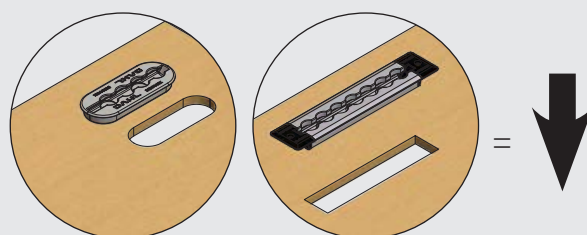

Sæt med 4 punkt WTORS - CLASSIC Line 85 kg

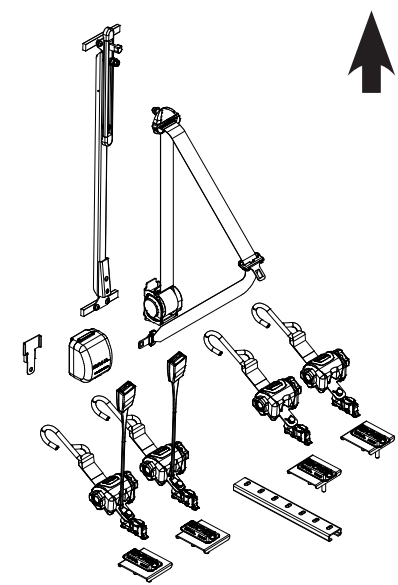

Art. nr. 501679
 MB Sprinter
 906 & 907 & 910
 VW Crafter (2006-2016)

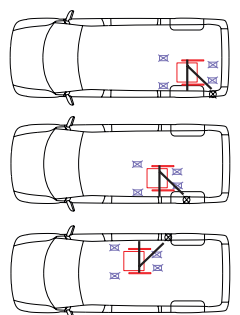
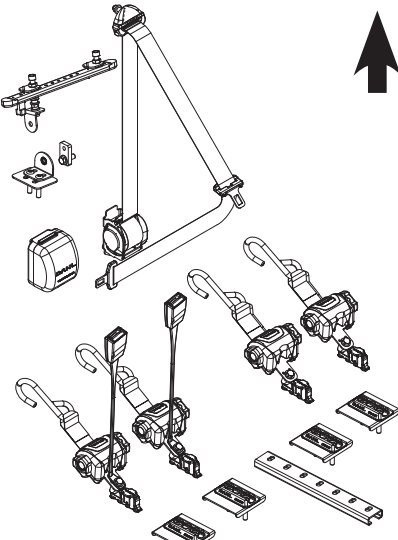
Art. nr. 501771
 Citroën Jumpy X
 Citroën Space Tourer /
 Jumpy KO 2016-
 Fiat Scudo X270
 Ford Transit Custom V362
 MB Vito 639 & V-Class W447
 Opel Zafira Life
 Peugeot Expert X
 Peugeot Traveller /
 Expert KO 2016-
 Toyota Proace / Verso 2016-
 VW T5 & T6

Art. nr. 501774
 VW T5 & T6

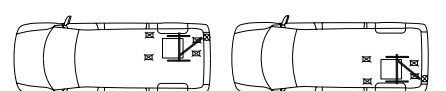
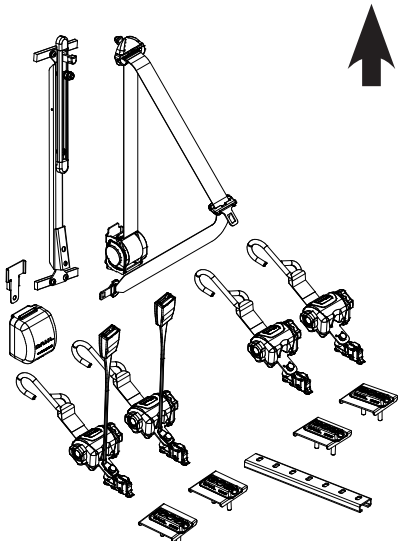
Art. nr. 501786
 VW T5 & T6

Art. nr. 501799
 Citroën Jumpy X
 Citroën Space Tourer /
 Jumpy KO 2016-
 Fiat Scudo X270
 Ford Transit Custom V362
 MB Vito 639 & V-Class W447
 Opel Zafira Life
 Peugeot Expert X
 Peugeot Traveller /
 Expert KO 2016-
 Toyota Proace / Verso 2016-
 VW T5 & T6

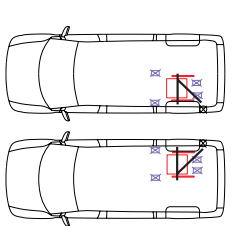
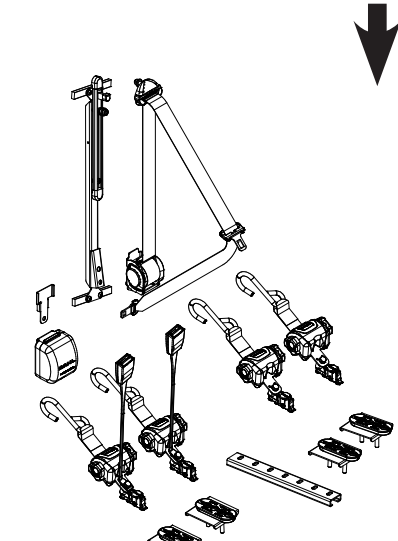
Art. nr. 501821
 MB Vito 639 & V-Class W447

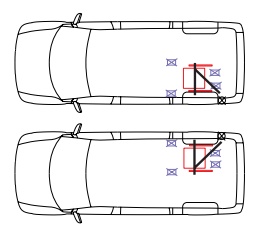
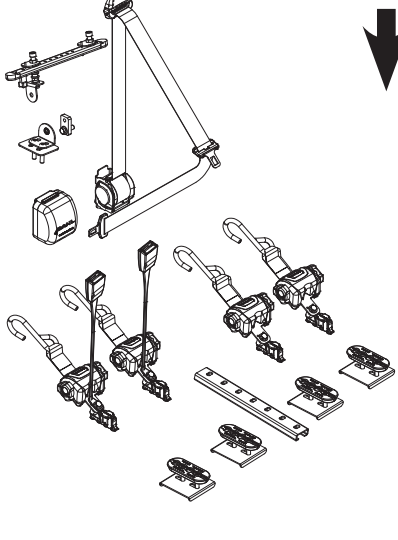

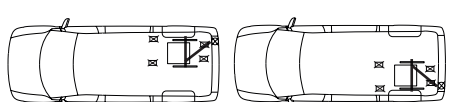
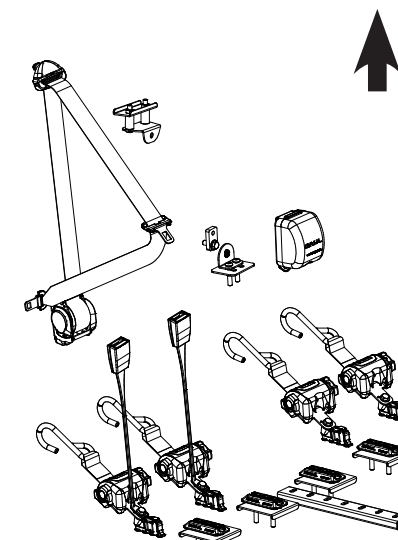
Sæt med 4 punkt WTORS - CLASSIC Line 85 kg

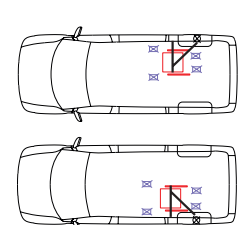
↓

Art. nr. 501932
MB Sprinter 906 & 907 & 910
VW Crafter (2006-2016)

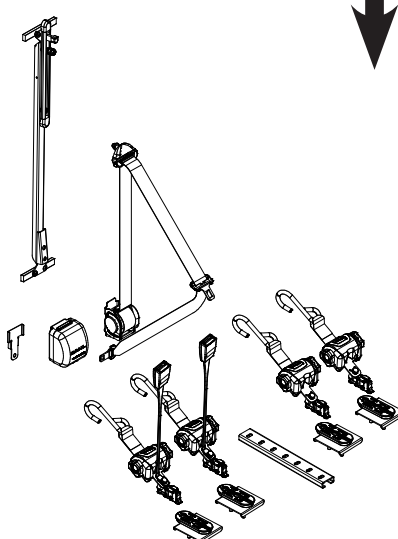
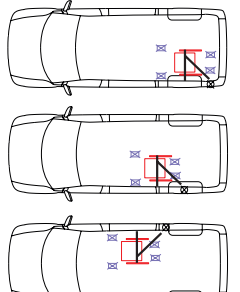
↑

Art. nr. 501942
Opel Movano X62 L1, L2, L3, L4
Renault Master X62 L1, L2, L3, L4
Nissan NV400 L1, L2, L3, L4

↓

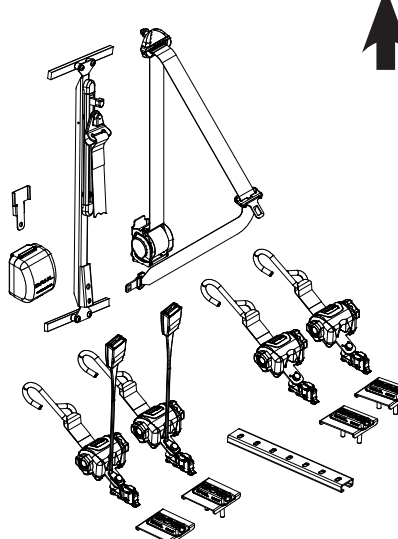
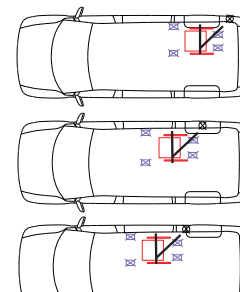
Art. nr. 501943
Opel Movano X62 L1, L2, L3, L4
Renault Master X62 L1, L2, L3, L4
Nissan NV400 L1, L2, L3, L4

↓

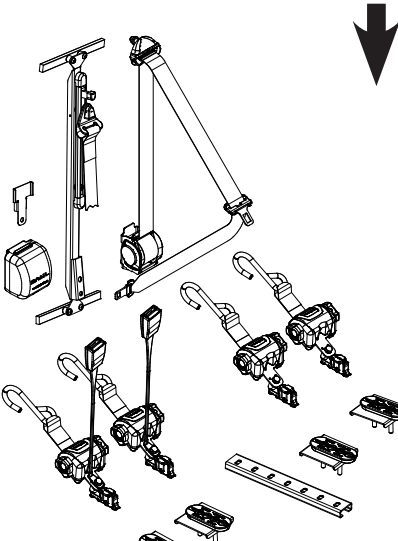
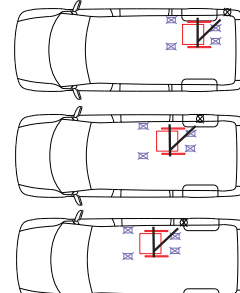
Art. nr. 501944
Fiat Ducato X250
Peugeot Boxer Y
Citroën Jumper Y

↑

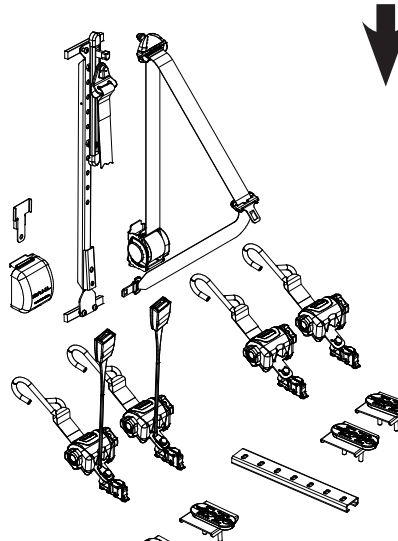
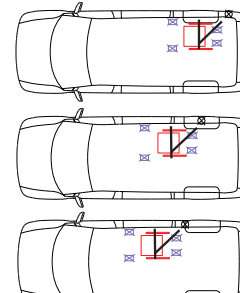
Art. nr. 501945
Fiat Ducato X250
Peugeot Boxer Y
Citroën Jumper Y



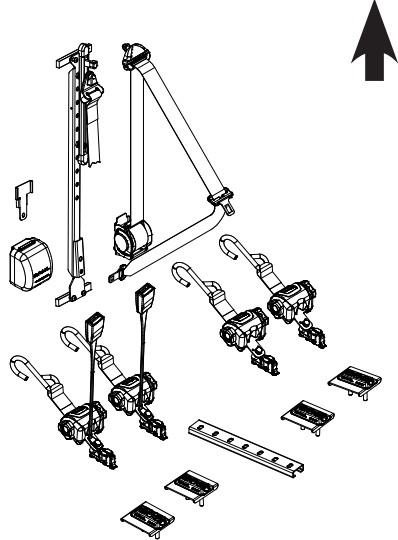
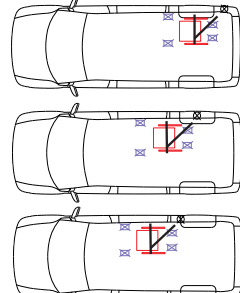

↓

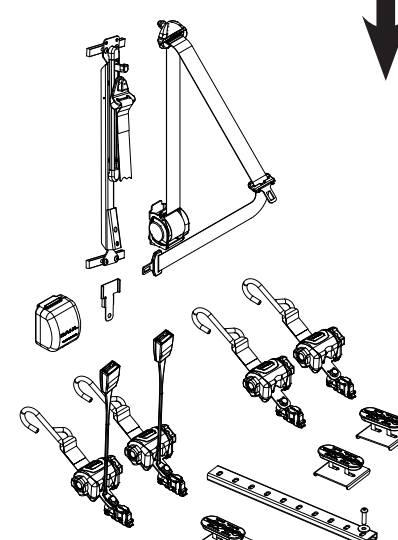
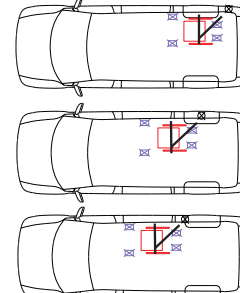
Art. nr. 501946
Ford Transit Custom V362
Nissan NV 200

Sæt med 4 punkt WTORS - CLASSIC Line 85 kg

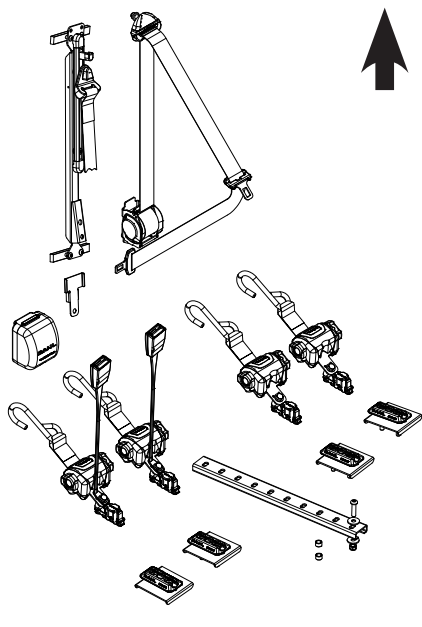

Art. nr. 501947
 Ford Transit Custom V362
 Nissan NV 200

Art. nr. 501948
 Citroën Jumpy X
 Fiat Scudo X270
 Peugeot Expert X
 Toyota Proace

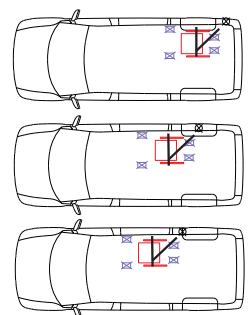
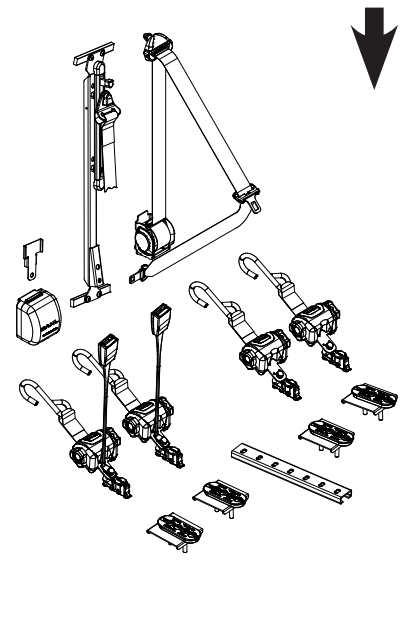
Art. nr. 501949
 Citroën Jumpy X
 Fiat Scudo X270
 Peugeot Expert X
 Toyota Proace

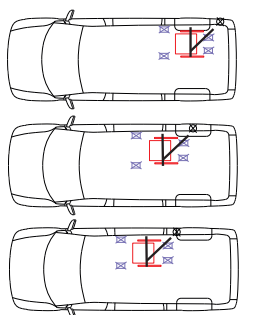
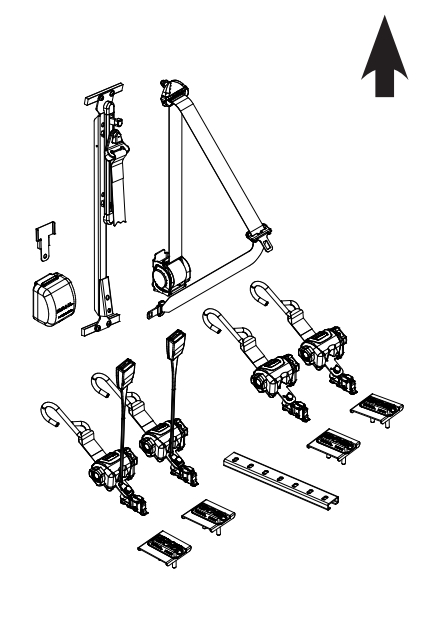
Art. nr. 502055
 Ford Transit V363

Art. nr. 502056
 Ford Transit V363

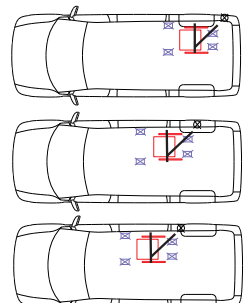
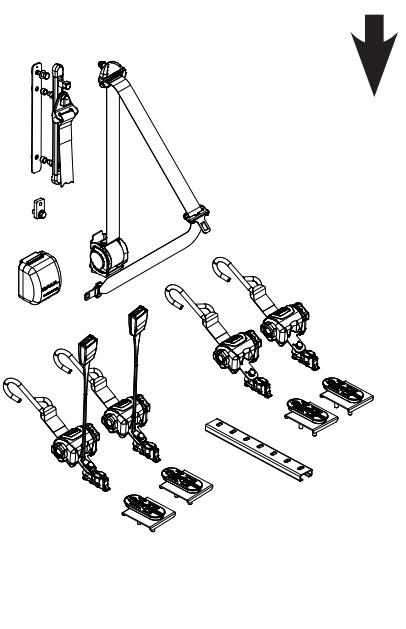

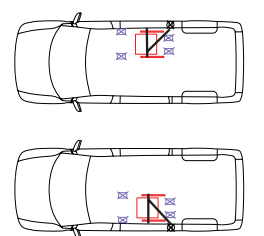
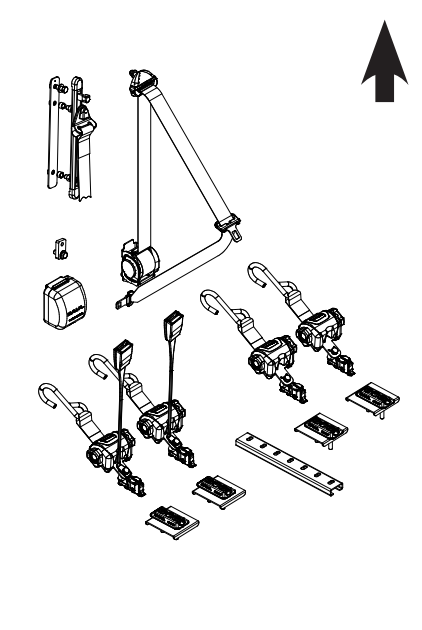

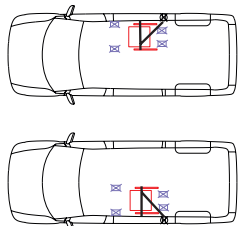
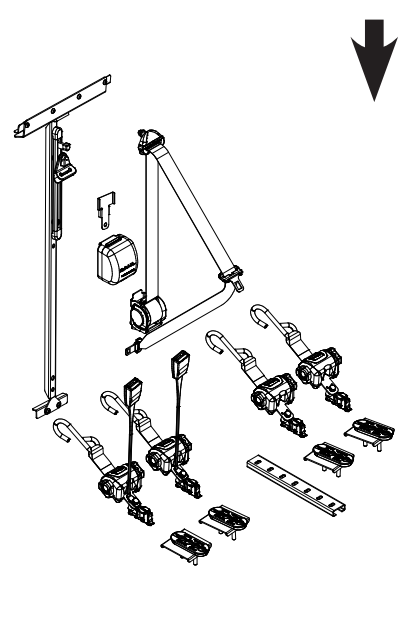
Art. nr. 502059
 Ford Transit V363

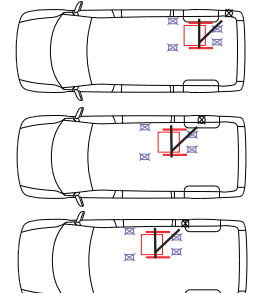

Sæt med 4 punkt WTORS - CLASSIC Line 85 kg

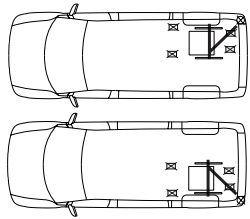
Art. nr. 502057
Fiat Talento
Ford Transit V363
Ford Transit Custom V362
MAN TGE 2017-
MB Sprinter 906 & 907 & 910
Nissan Primastar
Nissan NV300
Nissan NV400
Opel Vivaro X82 & X83
Opel Movano X62
Renault Master X62
Renault Trafic X82 & X83
VW Crafter (2006-2016)
VW Crafter 2017-



Art. nr. 502057
Citroën Jumper Y
Citroën Jumpy X
Fiat Ducato X250
Fiat Scudo X270
Fiat Talento
Ford Transit Custom V362
MB Sprinter 906 & 907 & 910
MB Vito 639 & W447
Nissan NV300
Nissan NV400 L1, L2, L3, L4
Nissan Primastar
Opel Movano X62 L1, L2, L3, L4
Opel Vivaro X82 & X83
Peugeot Boxer Y
Peugeot Expert X
Renault Master X62 L1, L2, L3, L4
Renault Trafic X82 & X83
Toyota Proace
VW T5 & T6

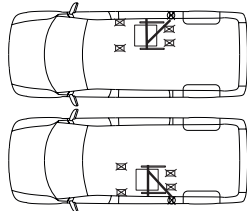

Art. nr. 502058
Fiat Talento
Ford Transit V363
Ford Transit Custom V362
MAN TGE 2017-
MB Sprinter 906 & 907 & 910
Nissan Primastar
Nissan NV300
Nissan NV400
Opel Vivaro X82 & X83
Opel Movano X62
Renault Master X62
Renault Trafic X82 & X83
VW Crafter (2006-2016)
VW Crafter 2017-

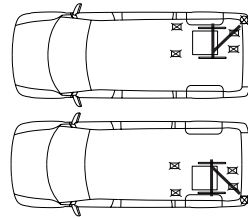

Art. nr. 502058
Citroën Jumper Y
Citroën Jumpy X
Fiat Ducato X250
Fiat Scudo X270
Fiat Talento
Ford Transit Custom V362
MB Sprinter 906 & 907 & 910
MB Vito 639 & W447
Nissan NV400 L1, L2, L3, L4
Nissan NV300
Nissan Primastar
Opel Movano X62 L1, L2, L3, L4
Opel Vivaro X82 & X83
Peugeot Boxer Y
Peugeot Expert X
Renault Master X62 L1, L2, L3, L4
Renault Trafic X82 & X83
Toyota Proace
VW T5 & T6

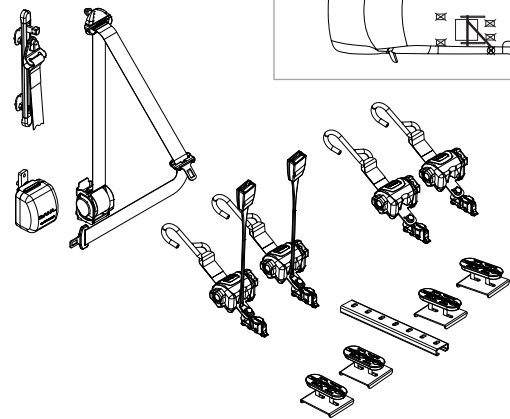
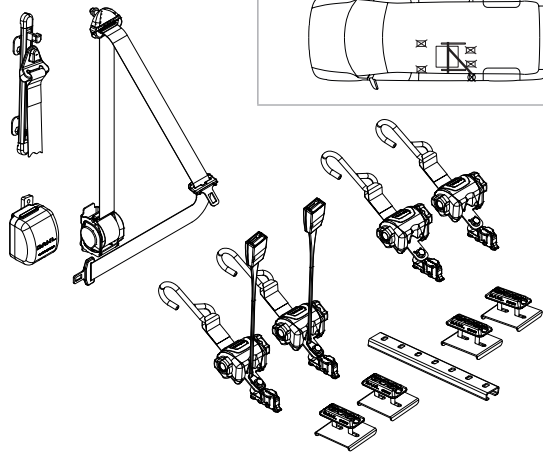
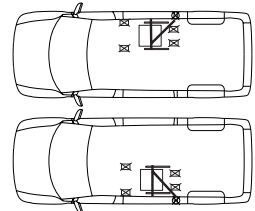

Art. nr. 502060

Ford Transit V363

Art. nr. 502062

MB Sprinter 906, 907, 910

VW Crafter 2006-2016

HIGH ROOF ONLY

Wheel bases:
3250 - 3665 - 4325

Sæt med 4 punkt WTORS - CLASSIC Line 85 kg

↑

Art. nr. 502063
MB Sprinter 906, 907, 910
VW Crafter 2006-2016
High roof only:
Wheel bases: 3250 - 3665 - 4325

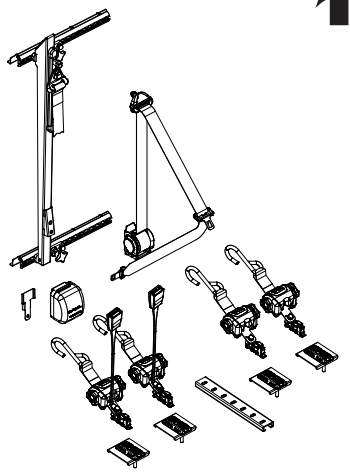
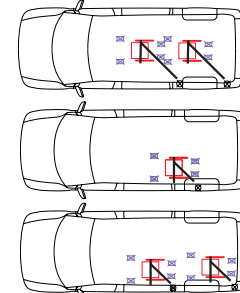
↓

Art. nr. 502239
MB Vito & V-Class W447

↑

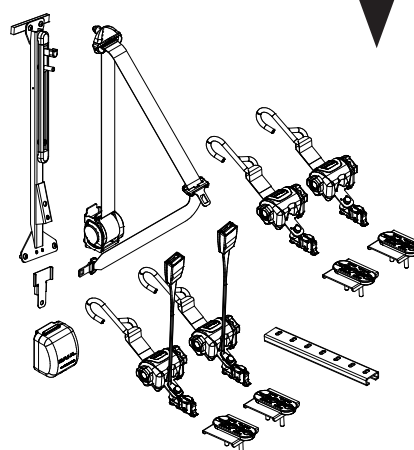
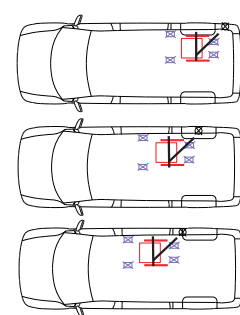
Art. nr. 502241
MB Vito & V-Class W447

↑

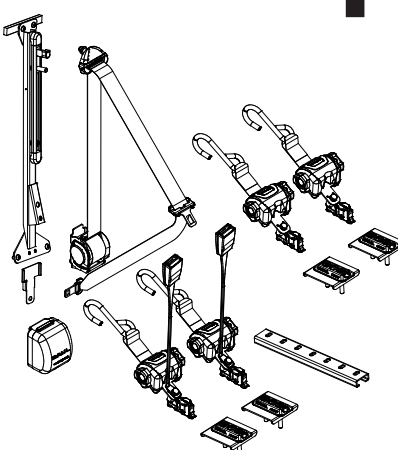
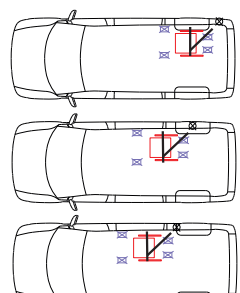
Art. nr. 502289
GM Coachwork Drop Floor Conversion:
VW Caravelle SE Colorado

↓

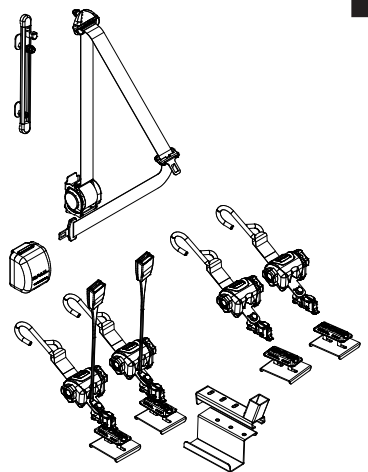
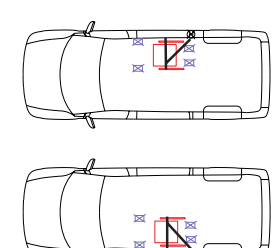
Art. nr. 502290
GM Coachwork Drop Floor Conversion:
VW Caravelle SE Colorado



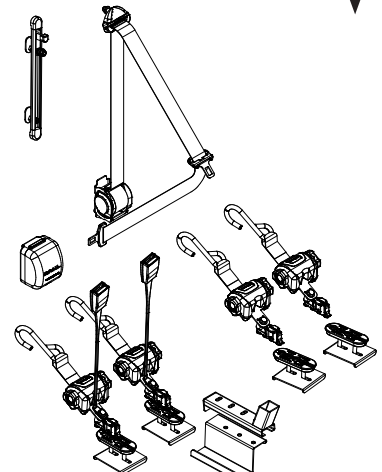
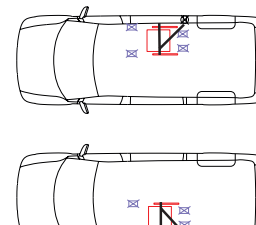

↓

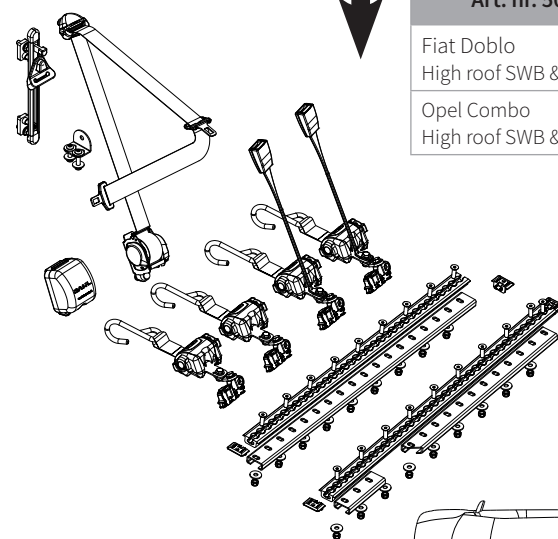
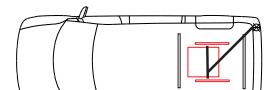
Art. nr. 502311
Fiat Doblo
High roof SWB & LWB
Opel Combo
High roof SWB & LWB

Sæt med 4 punkt WTORS - CLASSIC Line 85 kg

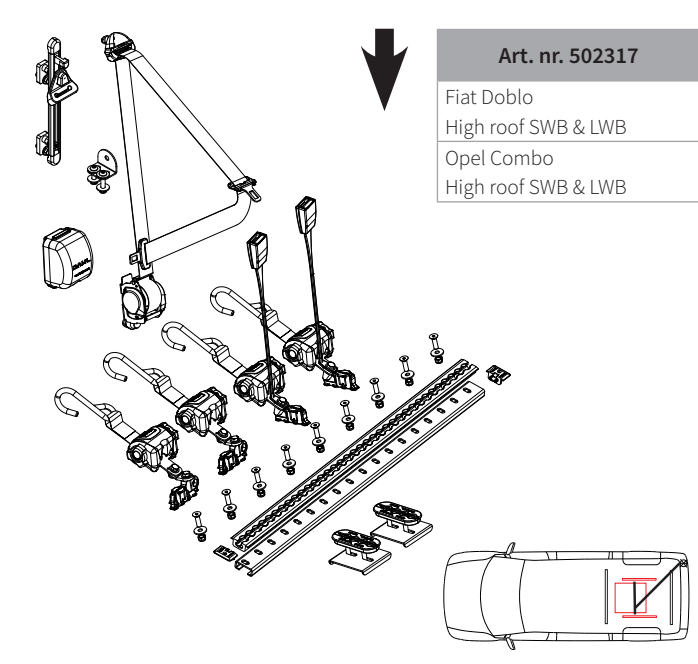

Art. nr. 502317
 Fiat Doblo
 High roof SWB & LWB
 Opel Combo
 High roof SWB & LWB

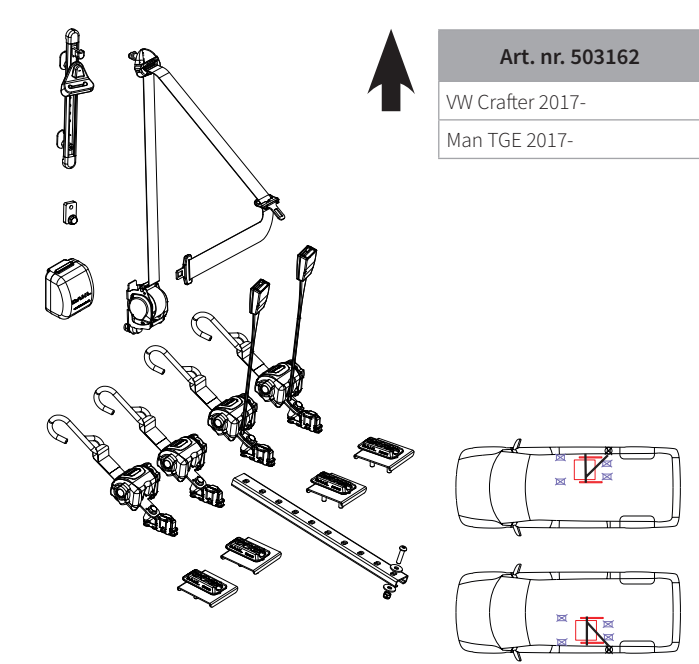

Art. nr. 503162
 VW Crafter 2017-
 Man TGE 2017-

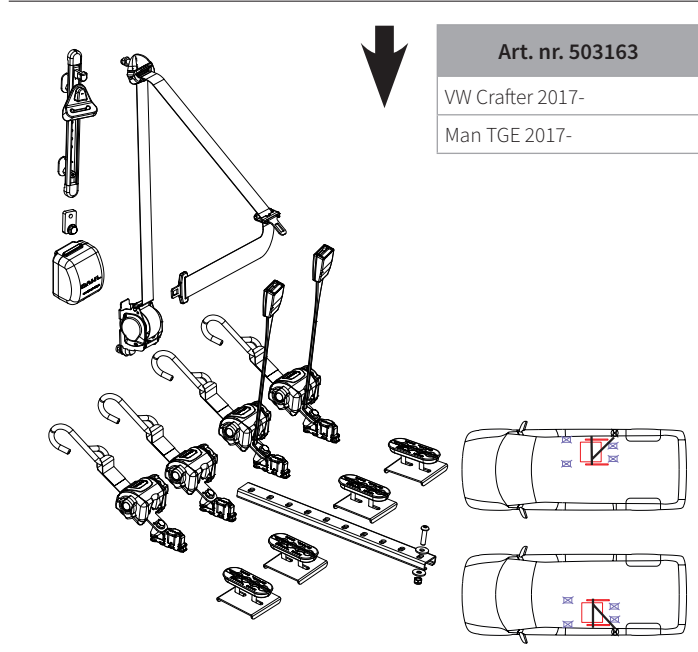

Art. nr. 503163
 VW Crafter 2017-
 Man TGE 2017-

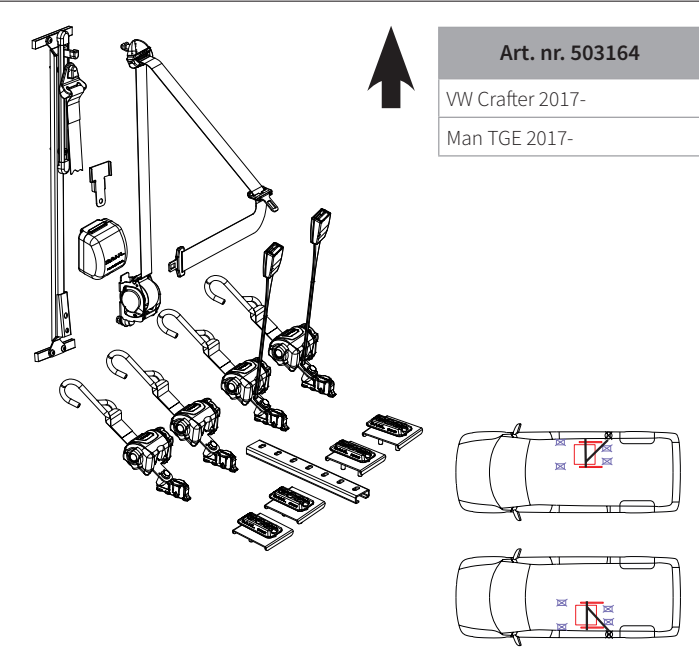

Art. nr. 503164
 VW Crafter 2017-
 Man TGE 2017-

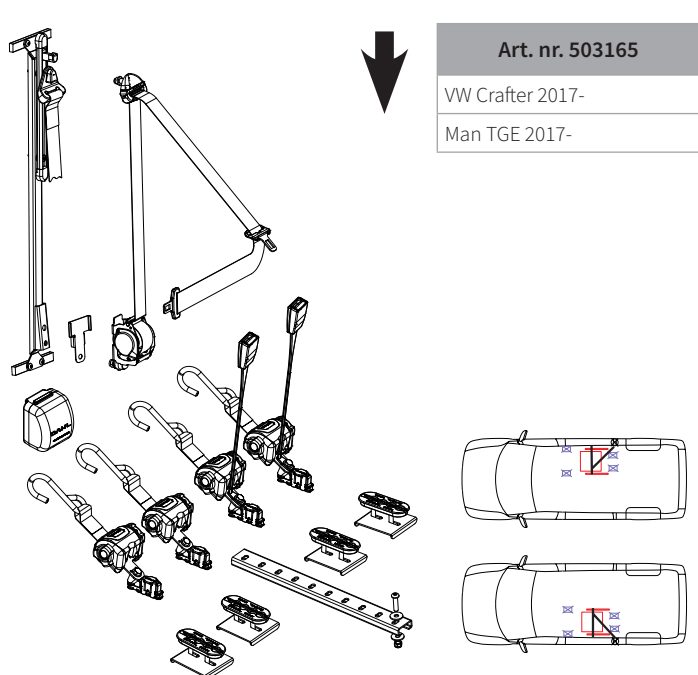

Art. nr. 503165
 VW Crafter 2017-
 Man TGE 2017-

Opgradering af 4-punkt EVOLUTION sæt fra 85 til 200 kg kørestolsklassificering, som pt bruger 4x 501906

På grund af stigende krav i udbud af offentlig transport og andre, der foreskriver, at 4-punkts fastspændingssystemer (WTORS) skal vurderes til den faktiske vægt af de transporterede kørestole, har vi besluttet at opgradere alle vores 85 kg EVOLUTION 4-punkt sæt med gulvbeslag som er monteret oven på gulv, undtagen monteringskinner på tværs. På denne måde er disse 85 kg WTORS-sæt compatible med vores HEAVY DUTY WTORS vurderet til 170 og 200 kg + bruger.

Derfor skal kunder, som har en af disse 85kg WTORS-sæt installeret i køretøjet og ønsker at opgradere dem med vores HEAVY DUTY WTORS, som er normeret til en kørestolsvægt på henholdsvis 170 eller 200 kg plus bruger, ikke gå tilbage til værkstedet for at have de stærkere 6-punkt HEAVY DUTY gulvbeslag monteret bagpå, hvilket sparer tid og ekstra arbejde. Det nye gulvbeslag sæt (2 x art.nr. 503251) til de bagerste fastspændingsstroppe eller retraktorer, som erstatter 2 x art.nr. 501906, kan ses her:

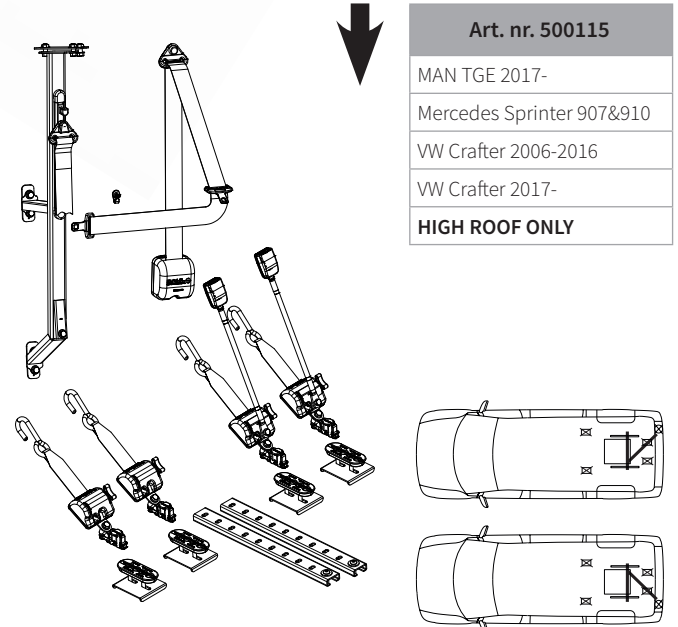
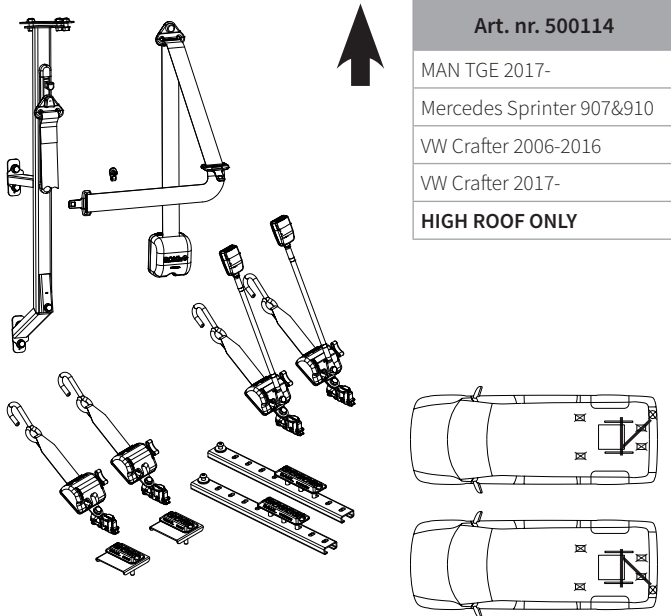

Sæt med 4 punkt WTORS - EVOLUTION Line 85 kg

Art. nr. 502372

Fiat Doblo
High roof SWB & LWB

Opel Combo
High roof SWB & LWB

Art. nr. 502373

Fiat Doblo
High roof SWB & LWB

Opel Combo
High roof SWB & LWB

Art. nr. 503122

VW T6 Multivan
standard roof height
original floor rails

Art. nr. 503130

MAN TGE 2017-
VW Crafter 2017-

Art. nr. 503131

MAN TGE 2017-
VW Crafter 2017-

Art. nr. 503132

MAN TGE 2017-
VW Crafter 2017-

Sæt med 4 punkt WTORS - EVOLUTION Line 85 kg

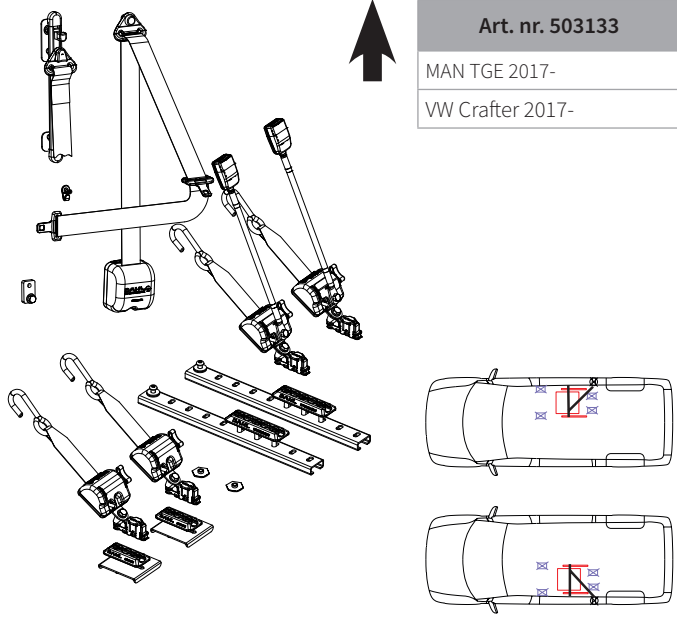

Art. nr. 503133
MAN TGE 2017-
VW Crafter 2017-

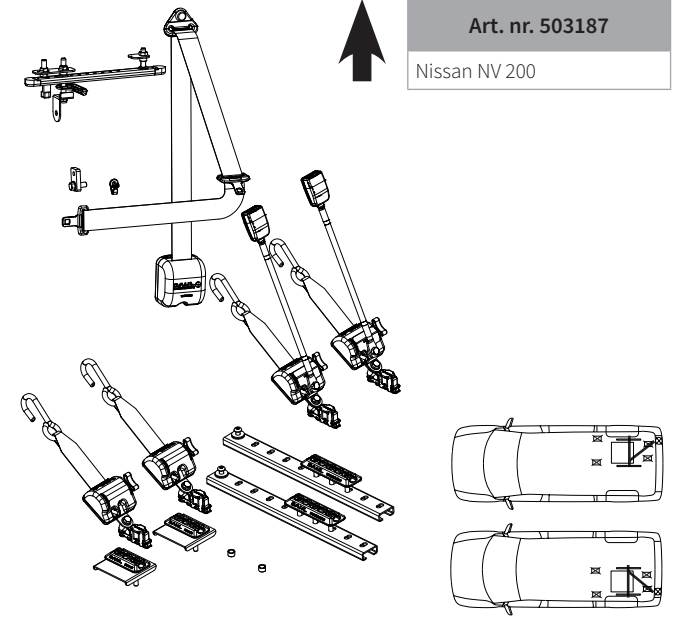

Art. nr. 503187
Nissan NV 200

Art. nr. 503170
Fiat Talento
Ford Transit V363
Ford Transit Custom V362
Man TGE 2017-
MB Sprinter 906 & 907 & 910
Nissan Primastar
Nissan NV300
Nissan NV400
Opel Vivaro X82 & X83
Opel Movano X62
Renault Master X62
Renault Trafic X82 & X83
VW Crafter 2006-2016
VW Crafter 2017-
VW T5 & T6

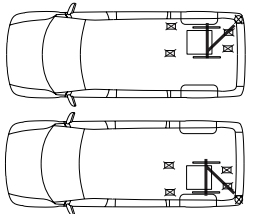

Art. nr. 503170
Citroën Jumper Y
Citroën Jumpy X
Fiat Ducato X250
Fiat Scudo X270
Fiat Talento
Ford Transit Custom V362
MB Sprinter 906 & 907 & 910
MB Vito V-Class W639 & W447
Nissan NV300
Nissan NV400
Nissan Primastar
Opel Movano X62
Opel Vivaro X82 & X83
Peugeot Boxer Y
Peugeot Expert X
Renault Master X62
Renault Trafic X82 & X83
Toyota Proace
VW T5 & T6

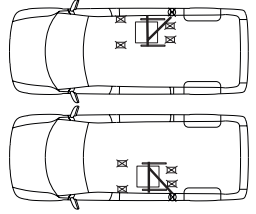

Art. nr. 503171
Fiat Talento
Ford Transit V363
Ford Transit Custom V362
Man TGE 2017-
MB Sprinter 906 & 907 & 910
Nissan Primastar
Nissan NV300
Nissan NV400
Opel Vivaro X82 & X83
Opel Movano X62
Renault Master X62
Renault Trafic X82 & X83
VW Crafter 2006-2016
VW Crafter 2017-
VW T5 & T6

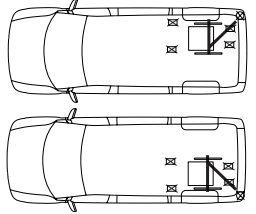

Art. nr. 503171
Citroën Jumper Y
Citroën Jumpy X
Fiat Ducato X250
Fiat Scudo X270
Fiat Talento
Ford Transit Custom V362
MB Sprinter 906 & 907 & 910
MB Vito V-Class W639 & W447
Nissan NV300
Nissan NV400
Nissan Primastar
Opel Movano X62
Opel Vivaro X82 & X83
Peugeot Boxer Y
Peugeot Expert X
Renault Master X62
Renault Trafic X82 & X83
Toyota Proace
VW T5 & T6

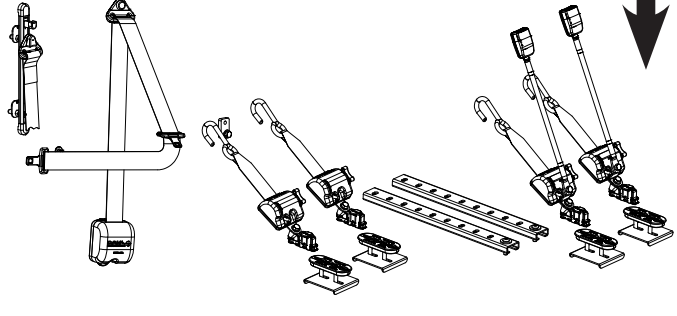
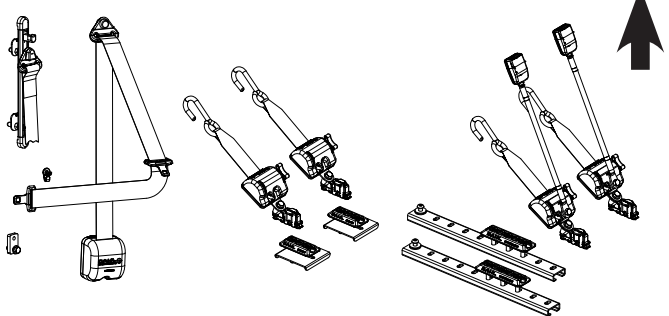
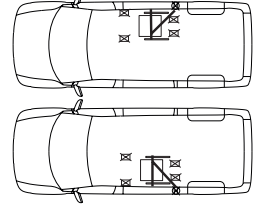

Sæt med 4 punkt WTORS - EVOLUTION Line 85 kg

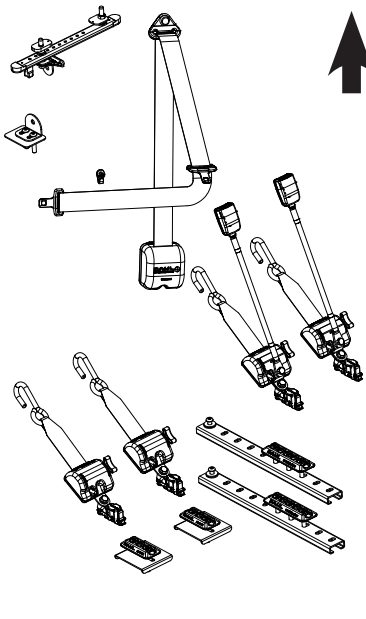

Art. nr. 503239
 ITEK Drop Floor
 Conversion:
 VW Caddy Active

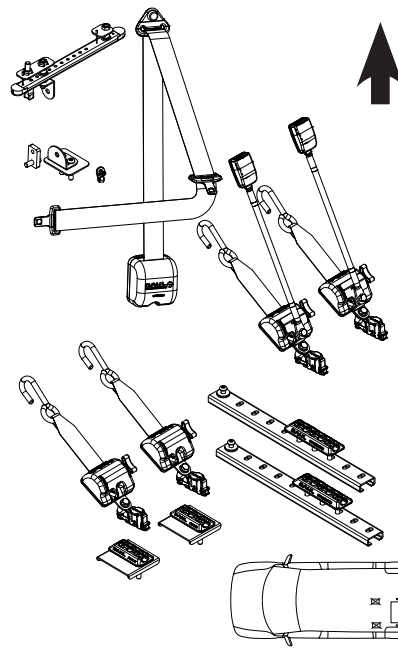
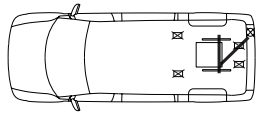

Art. nr. 503293
 Citroën Jumpy X
 Citroën Space Tourer /
 Jumpy KO 2016-
 Fiat Scudo X270
 Ford Transit Custom V362
 MB Vito V-Class W639& 447
 Opel Zafira Life
 Peugeot Expert X
 Peugeot Traveller /
 Expert KO 2016-
 Toyota Proace
 Toyota Proace / Verso 2016-
 VW T5 + T6

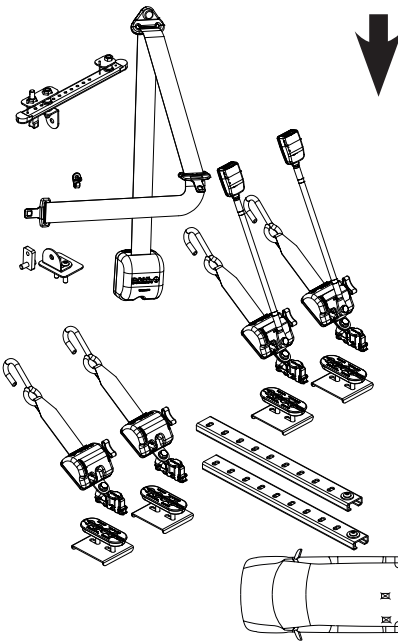
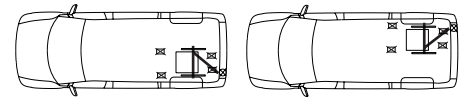

Art. nr. 503294
 Citroën Jumpy X
 Citroën Space Tourer /
 Jumpy KO 2016-
 Fiat Scudo X270
 Ford Transit Custom V362
 MB Vito V-Class W639& 447
 Opel Zafira Life
 Peugeot Expert X
 Peugeot Traveller /
 Expert KO 2016-
 Toyota Proace
 Toyota Proace / Verso 2016-
 VW T5 + T6

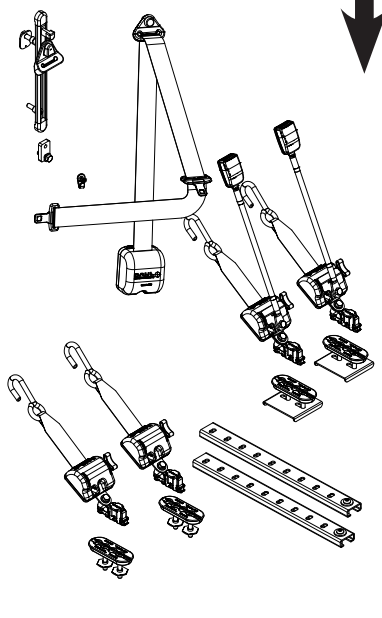
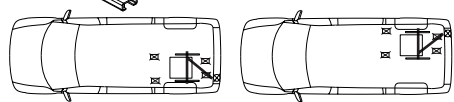

Art. nr. 503295
 Citroën Space Tourer /
 Jumpy KO
 Opel Zafira Life
 Peugeot Traveller /
 Expert KO
 Toyota Proace / Verso 2016-

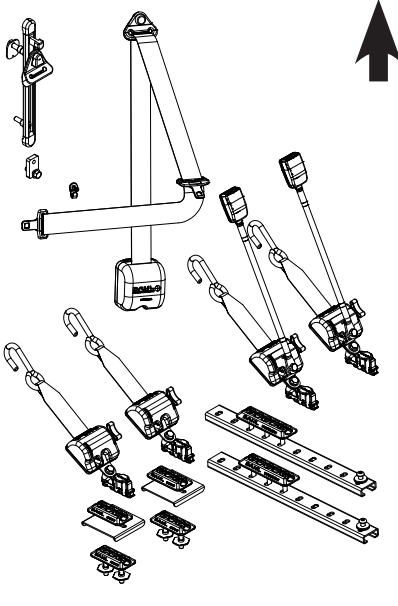
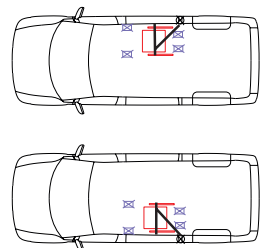

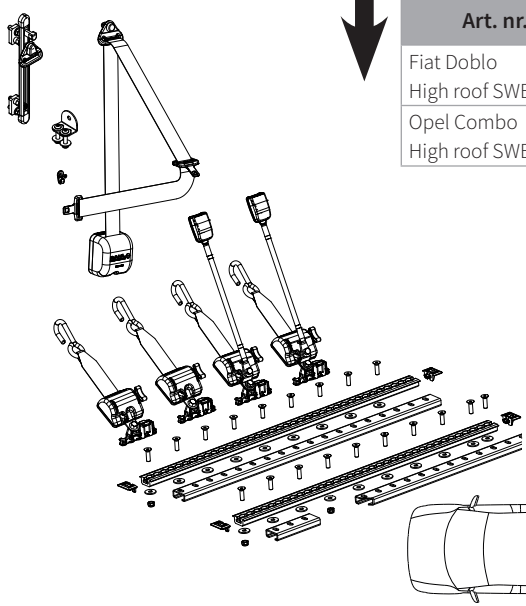
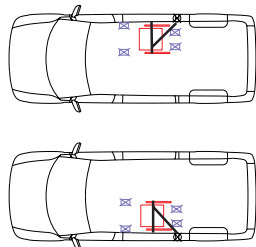

Art. nr. 503296
 Citroën Space Tourer /
 Jumpy KO
 Opel Zafira Life
 Peugeot Traveller /
 Expert KO
 Toyota Proace / Verso 2016-

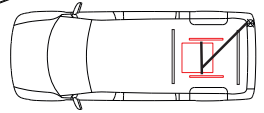

Art. nr. 503312
 Fiat Doblo
 High roof SWB & LWB
 Opel Combo
 High roof SWB & LWB

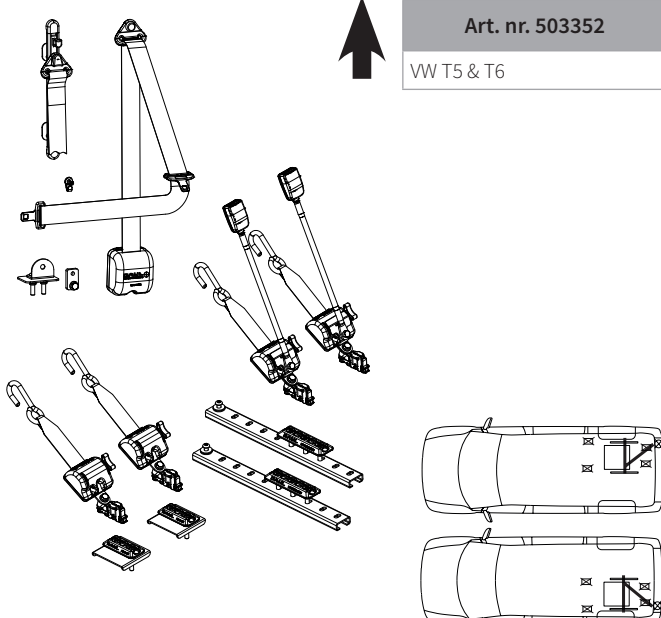
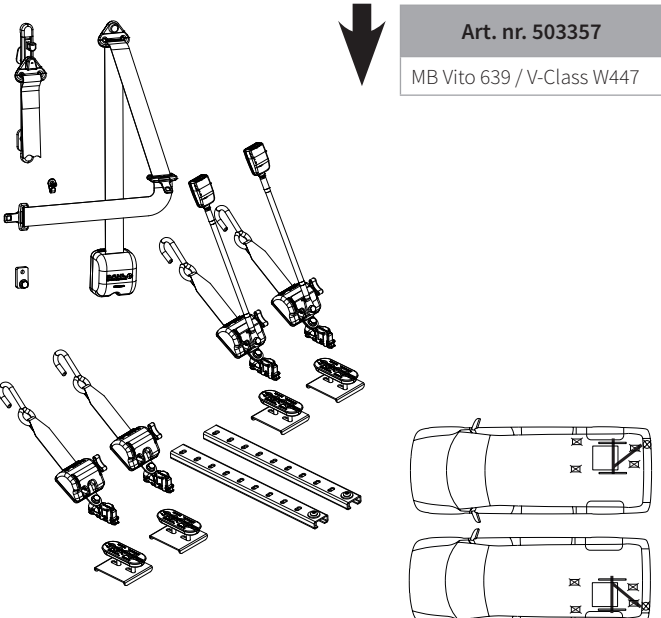
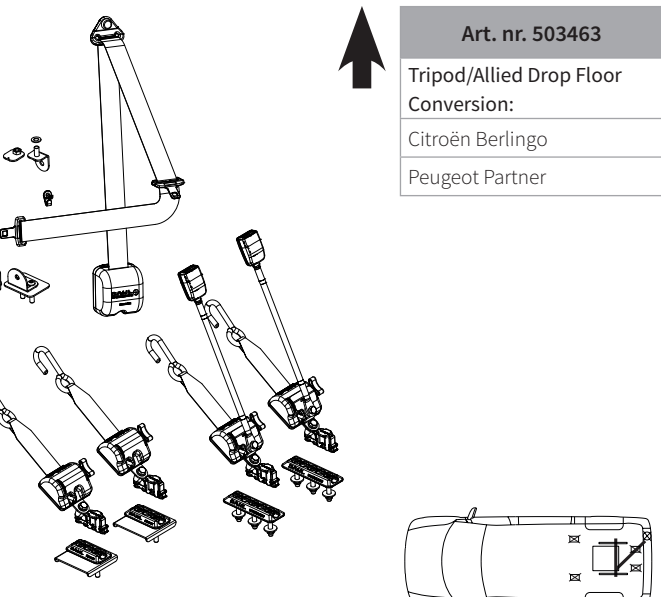
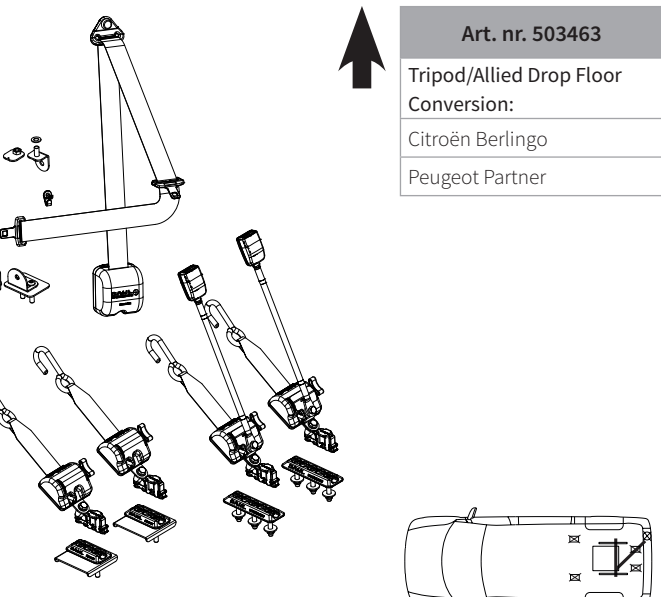

Sæt med 4 punkt WTORS - EVOLUTION Line 85 kg

	<p style="text-align: center;">Art. nr. 503352</p> <p style="text-align: center;">VW T5 & T6</p>		<p style="text-align: center;">Art. nr. 503353</p> <p style="text-align: center;">VW T5 & T6</p>
	<p style="text-align: center;">Art. nr. 503357</p> <p style="text-align: center;">MB Vito 639 / V-Class W447</p>		<p style="text-align: center;">Art. nr. 503358</p> <p style="text-align: center;">MB Vito 639 / V-Class W447</p>
	<p style="text-align: center;">Art. nr. 503463</p> <p style="text-align: center;">Tripod/Allied Drop Floor Conversion: Citroën Berlingo Peugeot Partner</p>		<p style="text-align: center;">Art. nr. 503476</p> <p style="text-align: center;">GM Coachwork drop floor conversion: VW Caravelle SE Colorado</p>

Sæt med 4 punkt WTORS - EVOLUTION Line 85 kg

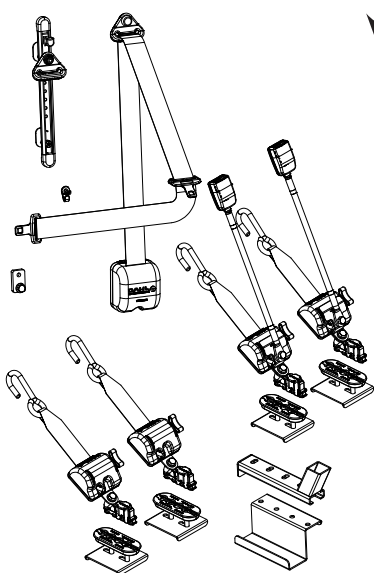

Art. nr. 503477
 GM Coachwork drop floor conversion:
 VW Caravelle SE Colorado

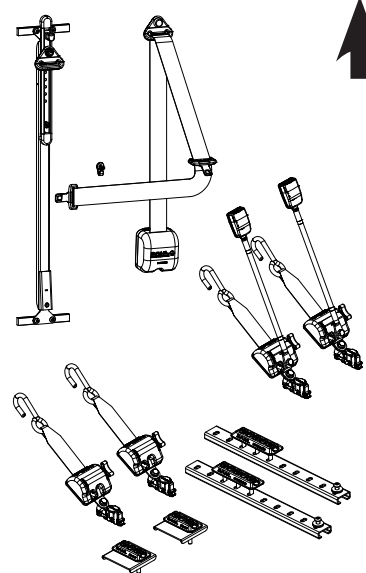
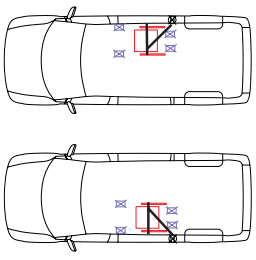

Art. nr. 503482
 MB Sprinter 906 & 907 & 910
 VW Crafter (2006-2016)

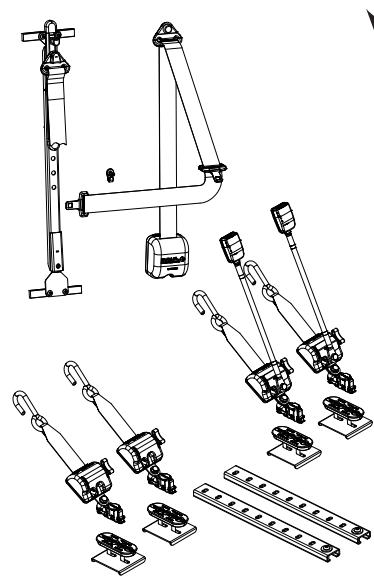
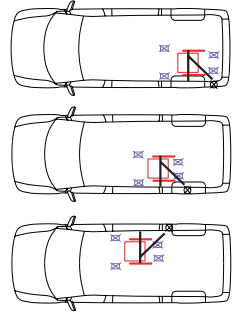

Art. nr. 503483
 Fiat Ducato X250
 Peugeot Boxer Y
 Citroën Jumper Y

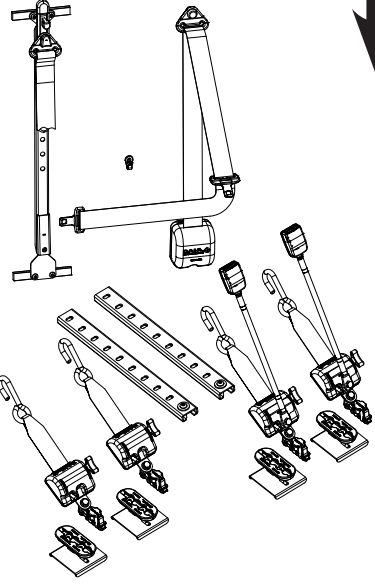
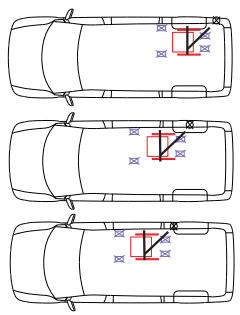

Art. nr. 502111
 Fiat Ducato X250
 Peugeot Boxer Y
 Citroën Jumper Y

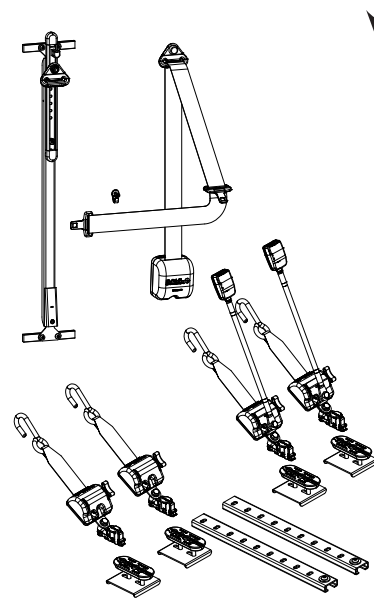
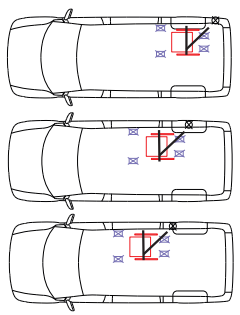

Art. nr. 503484
 MB Sprinter 906, 907 & 910
 VW Crafter 2006-2016

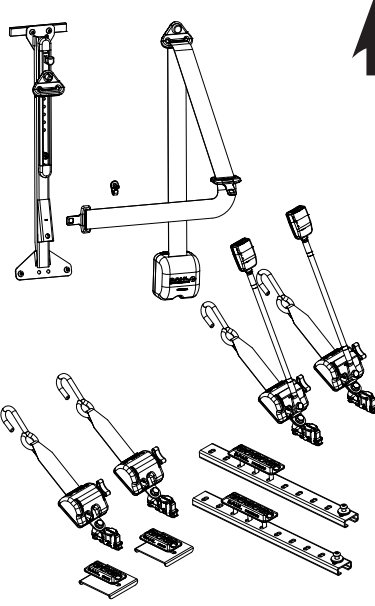
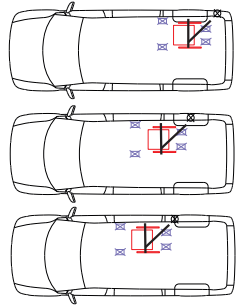

Art. nr. 503485
 MB Vito / V-Class W447

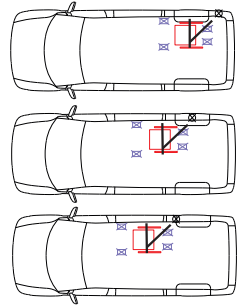

Sæt med 4 punkt WTORS - EVOLUTION Line 85 kg

Art. nr. 503486

Nissan NV200
Ford Transit Custom V362

Art. nr. 503487

Nissan NV200
Ford Transit Custom V362

Art. nr. 503736

Citroën Jumper Y
Fiat Ducato X250
Peugeot Boxer Y

Art. nr. 503737

Citroën Jumper Y
Fiat Ducato X250
Peugeot Boxer Y

Art. nr. 503738

Citroën Jumper Y
Fiat Ducato X250
Peugeot Boxer Y

Art. nr. 503739

Citroën Jumper Y
Fiat Ducato X250
Peugeot Boxer Y

Sæt med 4 punkt WTORS - EVOLUTION Line 85 kg

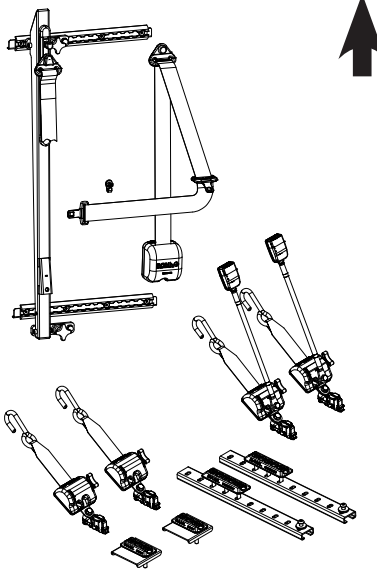

Art. nr. 500726
 MB Sprinter 906, 907 & 910
 VW Crafter 2006-2016
 Wheel Bases:
 3250, 3665, 4322
HIGH ROOF ONLY

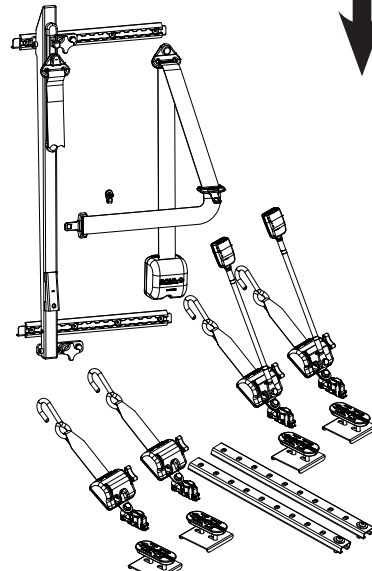
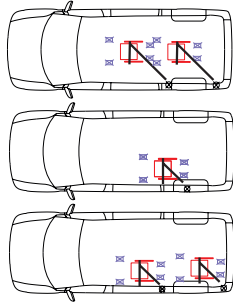

Art. nr. 500729
 MB Sprinter 906, 907 & 910
 VW Crafter 2006-2016
 Wheel Bases:
 3250, 3665, 4322
HIGH ROOF ONLY

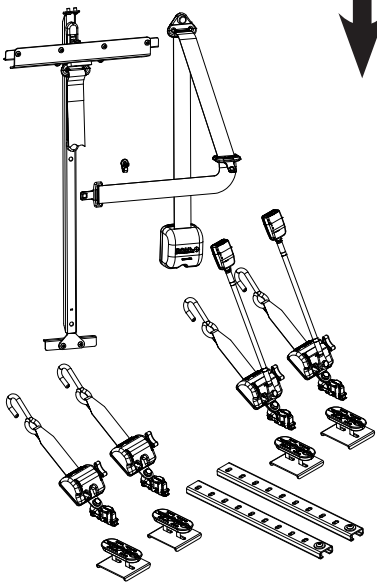
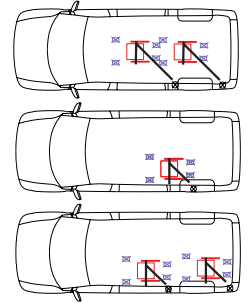

Art. nr. 501050
 Ford Transit V363

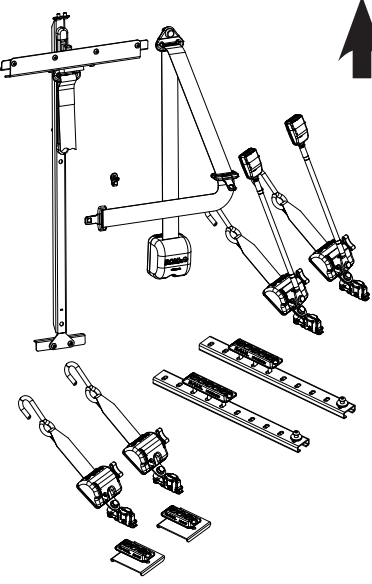
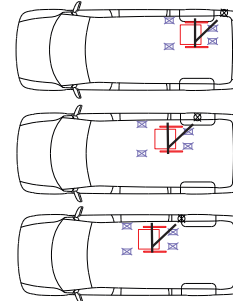

Art. nr. 501051
 Ford Transit V363

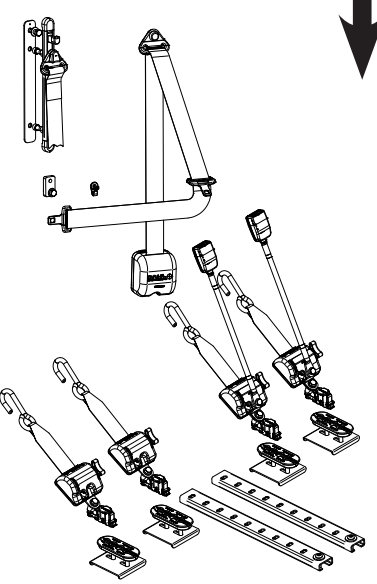
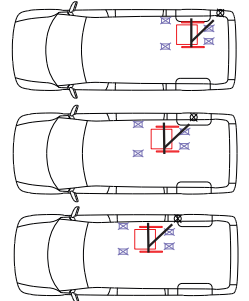

Art. nr. 501053
 Ford Transit V363

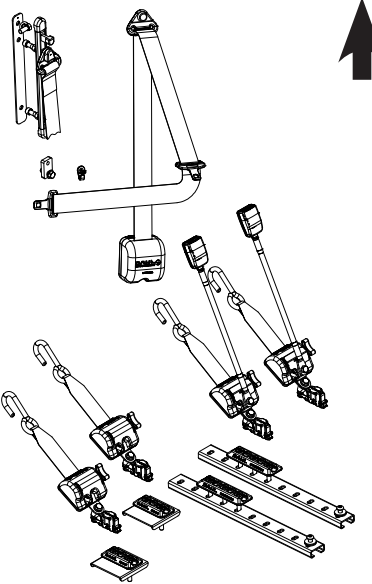
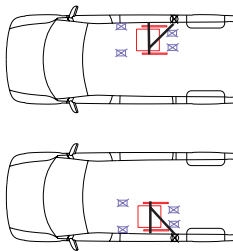

Art. nr. 501054
 Ford Transit V363

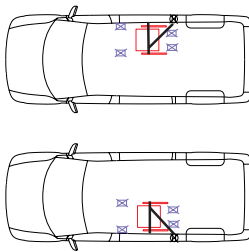

Sæt med 4 punkt WTORS - EVOLUTION Line 85 kg

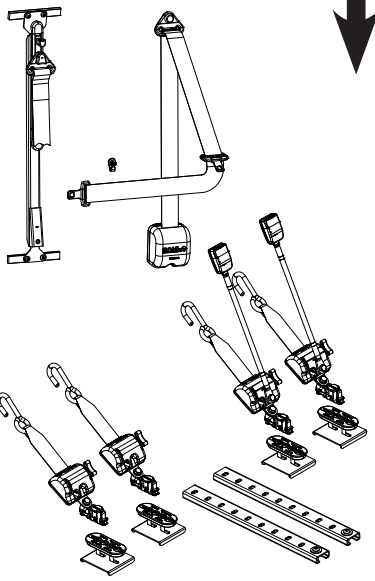

Art. nr. 501055	
Citroën Jumpy X	
Fiat Scudo X270	
Peugeot Expert X	
Toyota ProAce	

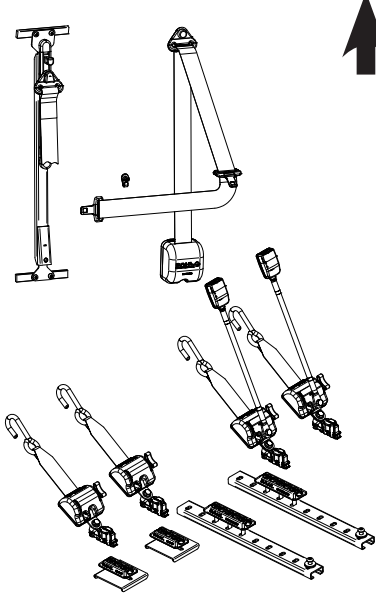
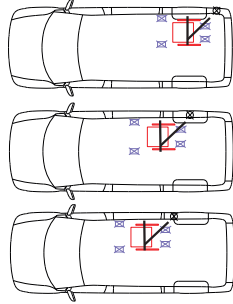

Art. nr. 501057	
Citroën Jumpy X	
Fiat Scudo X270	
Peugeot Expert X	
Toyota ProAce	

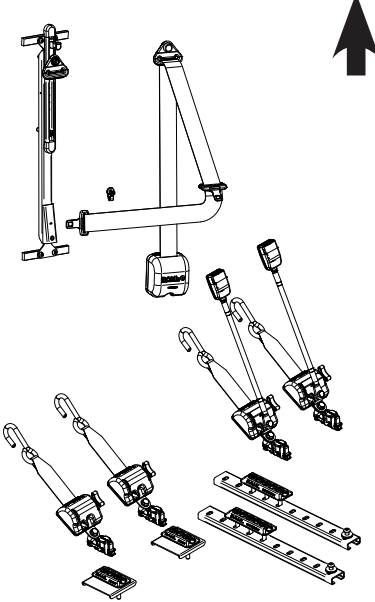
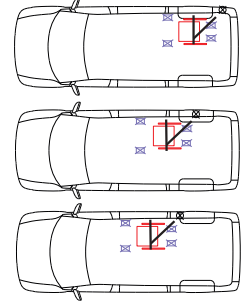

Art. nr. 501772	
VW Caravelle	
VW Transporter T5 & T6	

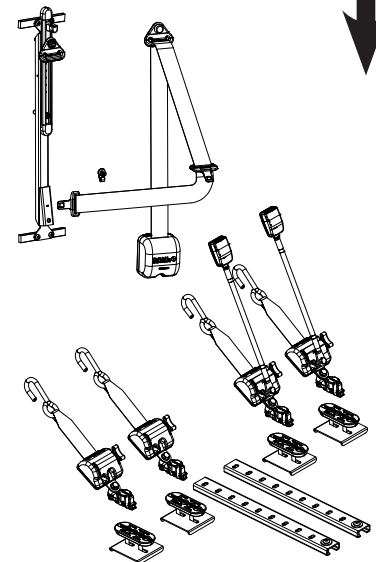
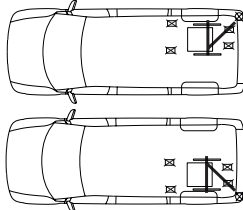

Art. nr. 501773	
VW Caravelle	
VW Transporter T5 & T6	

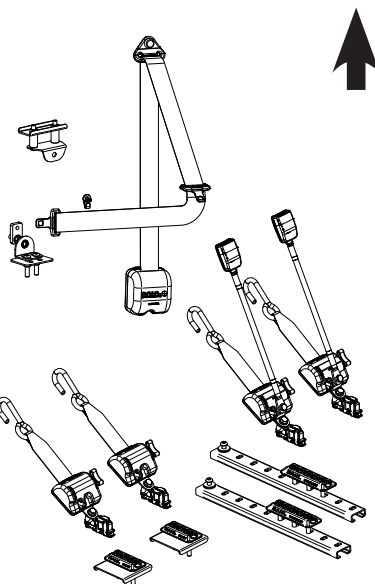
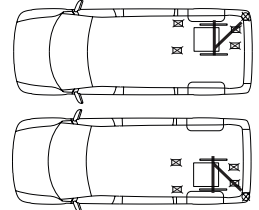

Art. nr. 501789	
MB Vito 639	
V-Class W447	

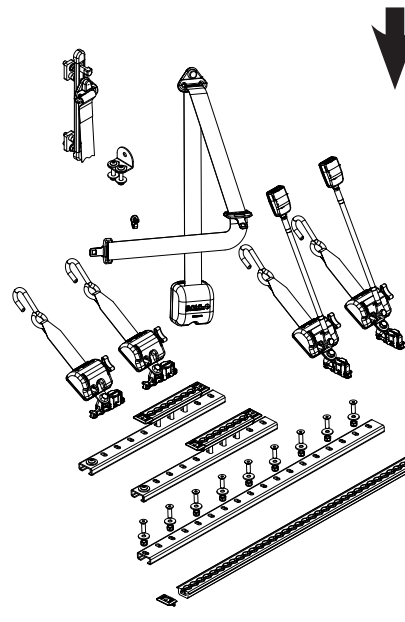
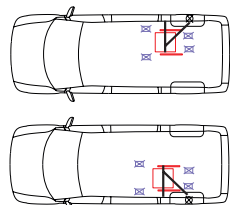

Art. nr. 501869	
High Roof SWB & LWB:	
Fiat Dublo	
Opel Combo	

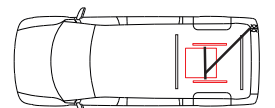

Sæt med 4 punkt WTORS - EVOLUTION Line 85 kg

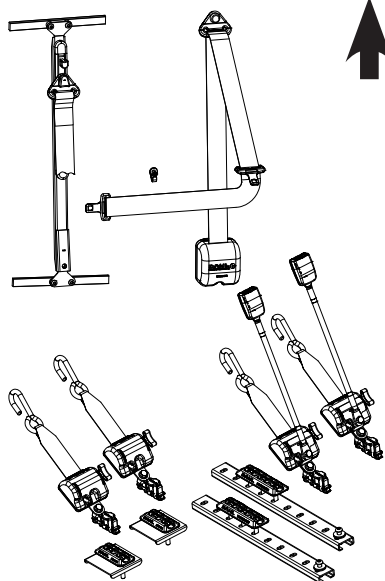

Art. nr. 501885
Opel Movano X62
Renault Master X62
Nissan NV400

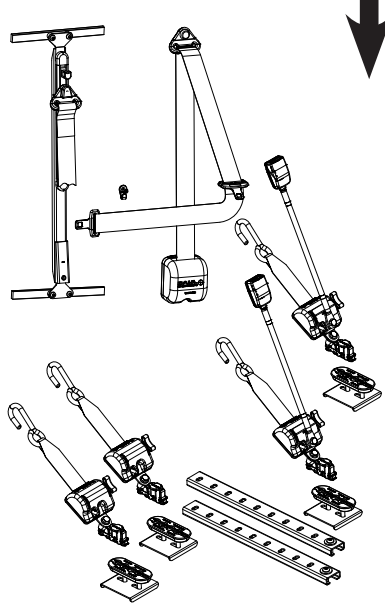
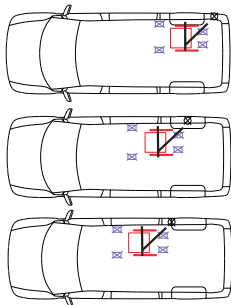

Art. nr. 501886
Opel Movano X62
Renault Master X62
Nissan NV400

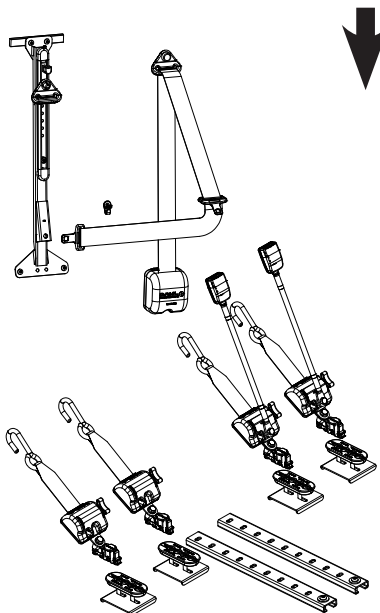
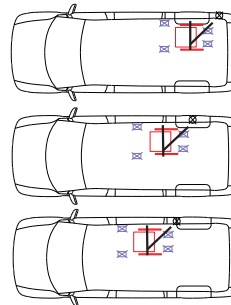

Art. nr. 503524
MB Vito & V-Class W447

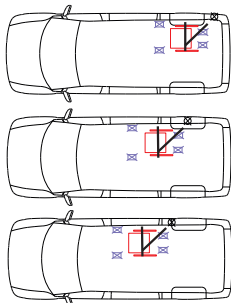

Sæt med 4 punkt WTORS - HEAVY DUTY Line 170 kg

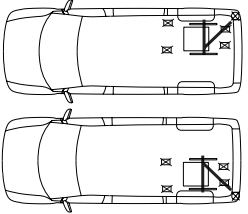

Art. nr. 503136
Fiat Talento X82
Ford Transit Custom V362
Man TGE 2017 - -
MB Sprinter 906, 907 & 910
Nissan NV300 & NV400
Opel Movano X62
Opel Vivaro X82 & X83
Renault Master X62
Renault Traffic X82 & X83
VW Crafter 2017-
VW T5 & T6



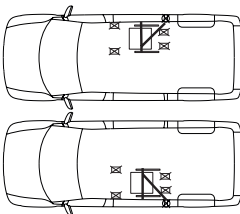
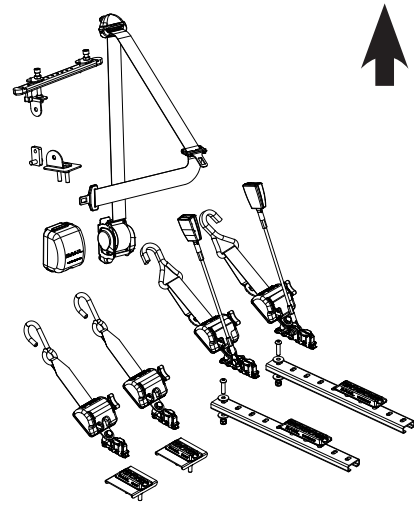

Art. nr. 503136
Citroën Jumper Y
Fiat Ducato X250
Fiat Talento X82
Ford Transit Custom V362
MB Vito V-Class W639 & W447
Nissan NV300 & NV400
Opel Movano X62
Opel Vivaro X82 & X83
Peugeot Boxer Y
Renault Master X62
Renault Traffic X82 & X83
VW T5 & T6

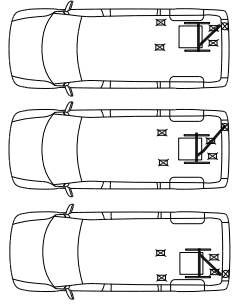

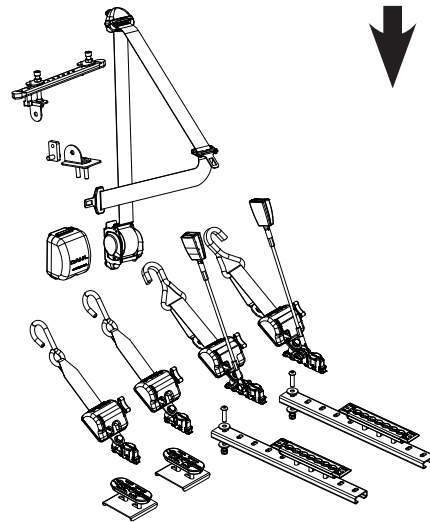
Art. nr. 503297
Citroën Jumpy / Space Tourer K0
Opel Zafira Life
Peugeot Expert / Traveller K0
Toyota Proace / Verso 2016-
MB Vito V-Class W639 & W447
VW T5 & T6

Art. nr. 503298
Citroën Jumpy / Space Tourer K0
MB Vito V-Class W639 & W447
Opel Zafira Life
Peugeot Expert / Traveller K0
Toyota Proace / Verso 2016-
VW T5 & T6

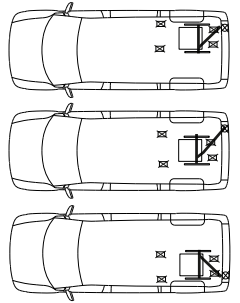
Art. nr. 503462
Tripod/Allied Drop Floor Conversion:
Citroën Berlingo
Peugeot Partner

Art. nr. 503473
Citroën Jumpy / Space Tourer K0
Opel Zafira Life
Peugeot Expert / Traveller K0
Toyota Proace / Verso 2016-

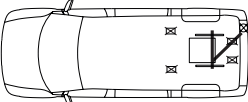

Sæt med 4 punkt WTORS - HEAVY DUTY Line 170 kg

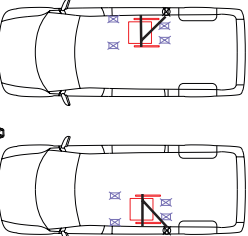
↓

Art. nr. 503475
Citroën Jumpy / Space Tourer K0
Opel Zafira Life
Peugeot Expert / Traveller K0
Toyota Proace / Verso 2016-

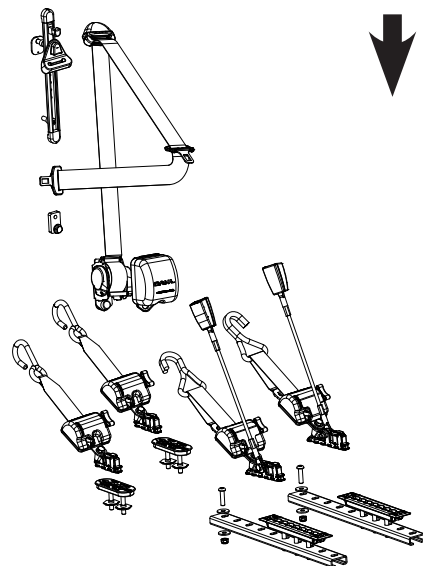
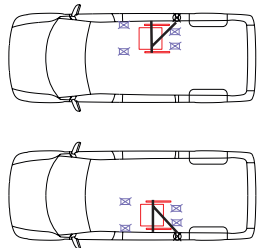
↑

Art. nr. 503478
GM Coachwork drop floor conversion:
VW Caravelle SE Colorado

↑

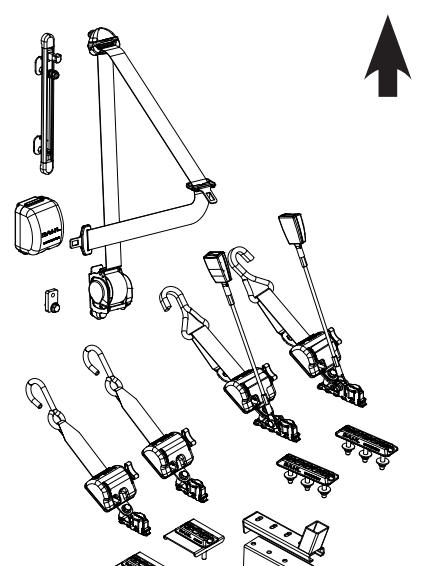
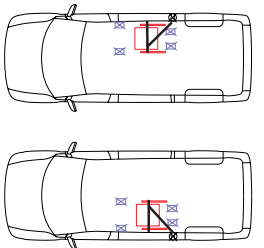
Art. nr. 503480
Fiat Doblo High roof SWB & LWB
Opel Combo High roof SWB & LWB

↓

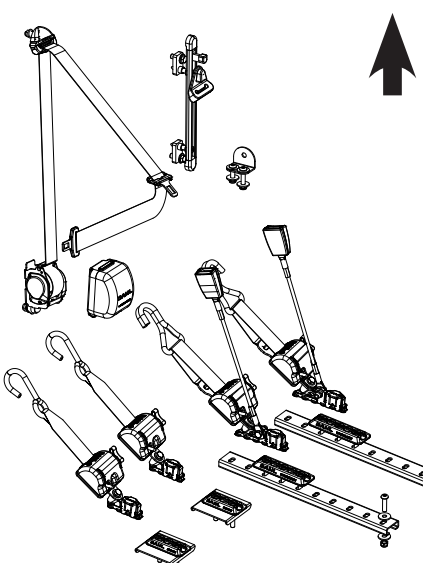
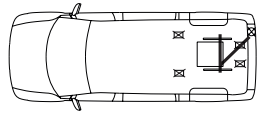
Art. nr. 503561
Fiat Doblo High roof SWB & LWB
Opel Combo High roof SWB & LWB

↓

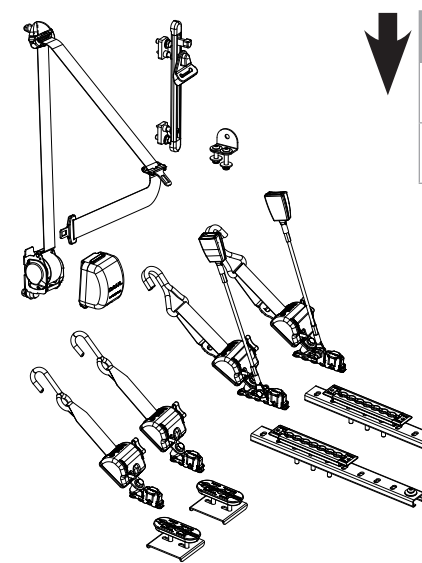
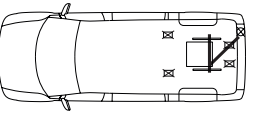
Art. nr. 503489
Man TGE 2017 -
VW Crafter 2017-



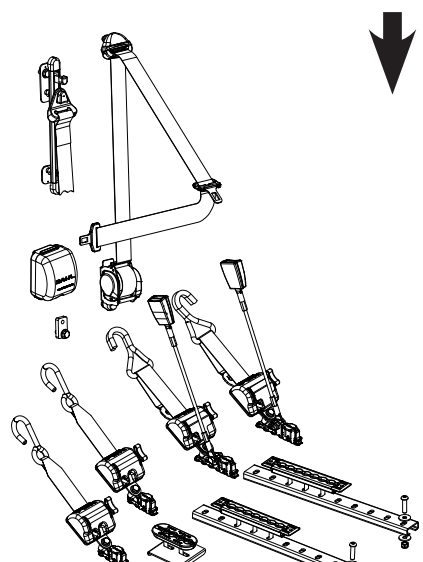
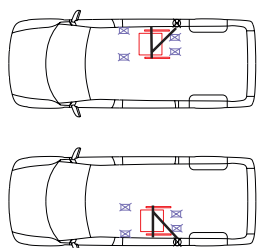

↑

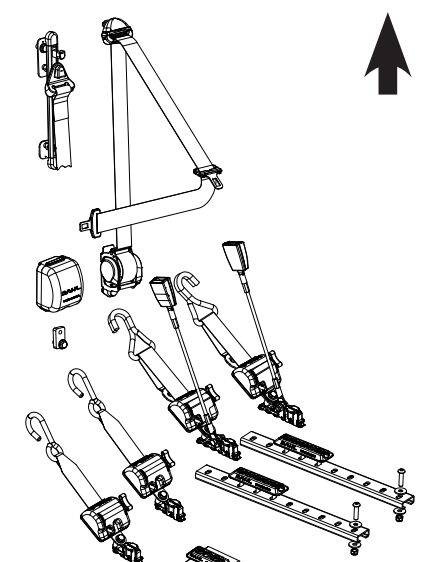
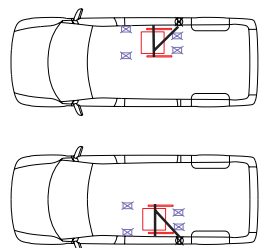
Art. nr. 503490
Man TGE 2017 -
VW Crafter 2017-



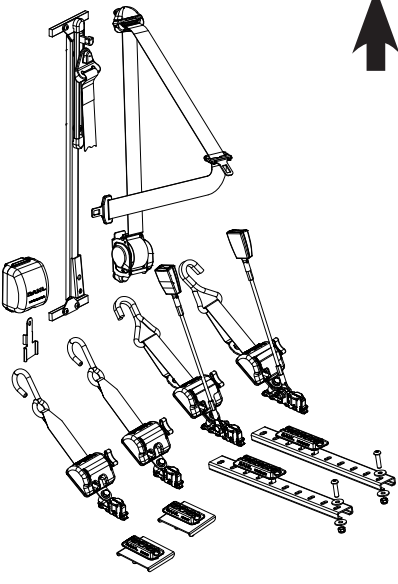

Sæt med 4 punkt WTORS - HEAVY DUTY Line 170 kg

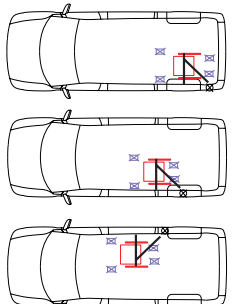
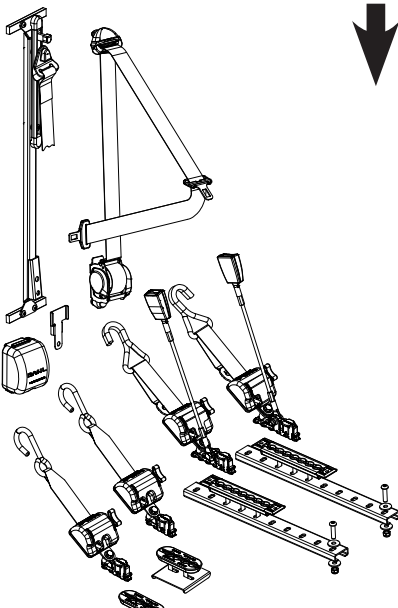

Art. nr. 503491

Man TGE 2017 -
VW Crafter 2017-

Art. nr. 503492

Man TGE 2017 -
VW Crafter 2017-

Art. nr. 503499

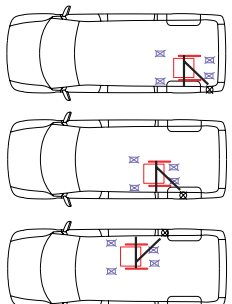
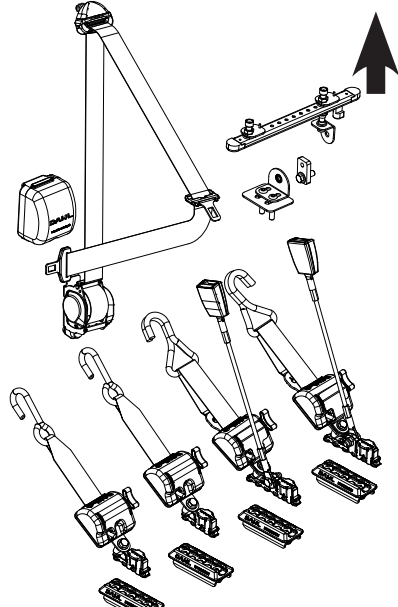
VW T5/T6
Multi Van & California
Standard roof height with
original VW floor rails



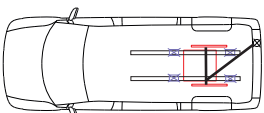

Art. nr. 503497

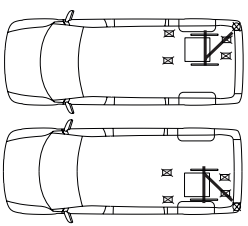
Fiat Talento X82
Ford Transit Custom V362
Man TGE 2017 - -
MB Sprinter 906 & 907 & 910
Nissan NV300 & NV400
Opel Movano X62
Opel Vivaro X82 & X83
Renault Master X62
Renault Traffic X82 & X83
VW Crafter 2017-
VW T5 & T6

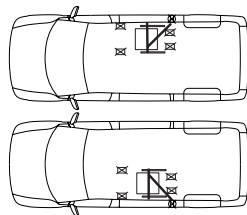
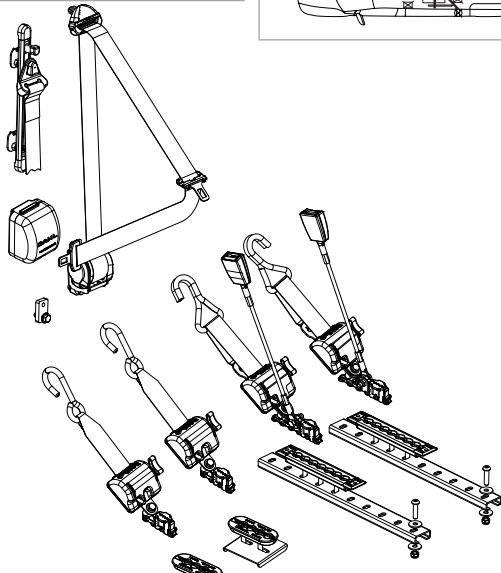

Art. nr. 503497

Citroën Jumper Y
Fiat Ducato X250
Fiat Talento X82
Ford Transit Custom V362
MB Vito V-Class W639 & W447
Nissan NV300 & NV400
Opel Movano X62
Opel Vivaro X82 & X83
Peugeot Boxer Y
Renault Master X62
Renault Traffic X82 & X83
VW T5 & T6

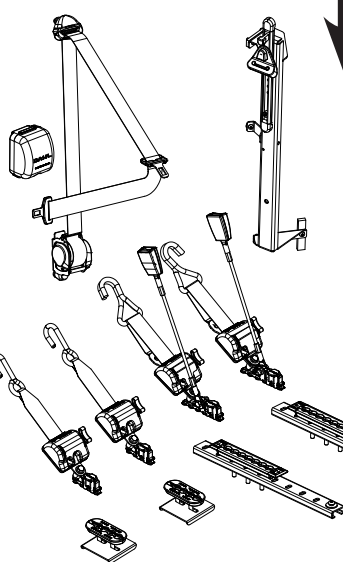
Art. nr. 503622

Citroën Jumper Y
Fiat Ducato X250
Peugeot Boxer Y

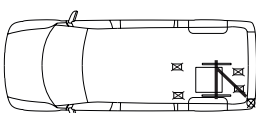

Sæt med 4 punkt WTORS - HEAVY DUTY Line 170 kg

Art. nr. 503602

Citroën Jumper Y
Fiat Ducato X250
Peugeot Boxer Y

Art. nr. 503603

Citroën Jumper Y
Fiat Ducato X250
Peugeot Boxer Y

Art. nr. 503623

Citroën Jumper Y
Fiat Ducato X250
Peugeot Boxer Y

Art. nr. 503664

Freedom Drop Floor Conversion:

Citroën Jumpy & Spacetourer KO
Opel Zafira Life
Peugeot Expert & Traveller KO
Toyota Proace & Proace Verso 2016-

Art. nr. 500116

MAN TGE 2017-
Mercedes Sprinter 907&910
VW Crafter 2006-2016
VW Crafter 2017-
HIGH ROOF ONLY

Art. nr. 500117

MAN TGE 2017-
Mercedes Sprinter 907&910
VW Crafter 2006-2016
VW Crafter 2017-
HIGH ROOF ONLY

Sæt med 4 punkt WTORS - HEAVY DUTY Line 200 kg

Art. nr. 503135
Fiat Talento X82
Ford Transit Custom V362
Man TGE 2017 - -
MB Sprinter 906, 907 & 910
Nissan NV300 & NV400
Opel Movano X62
Opel Vivaro X82 & X83
Renault Master X62
Renault Traffic X82 & X83
VW Crafter 2017-
VW T5 & T6

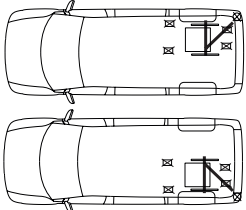

Art. nr. 503135
Citroën Jumper Y
Fiat Ducato X250
Fiat Talento X82
Ford Transit Custom V362
MB Sprinter 906, 907, 910
MB Vito V-Class W639 & W447
Nissan NV300 & NV400
Opel Movano X62
Opel Vivaro X82 & X83
Peugeot Boxer Y
Renault Master X62
Renault Traffic X82 & X83
VW T5 & T6

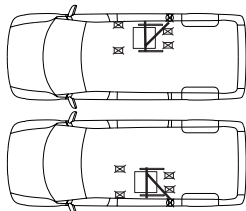
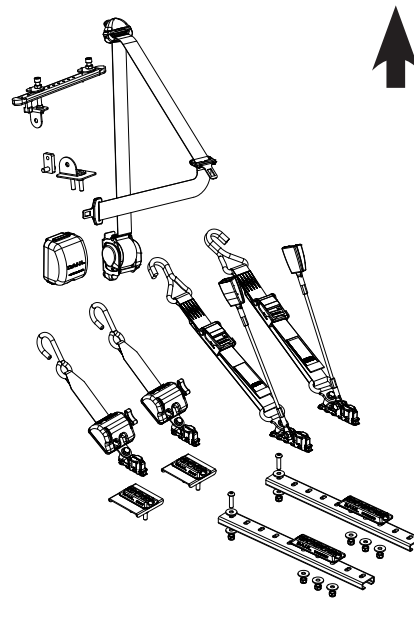
Art. nr. 503299
Citroën Jumpy / Space Tourer K0
MB Vito/V-Class W639 & 447
Opel Zafira Life
Peugeot Expert / Traveller K0
Toyota Proace / Verso 2016-
VW T5& T6

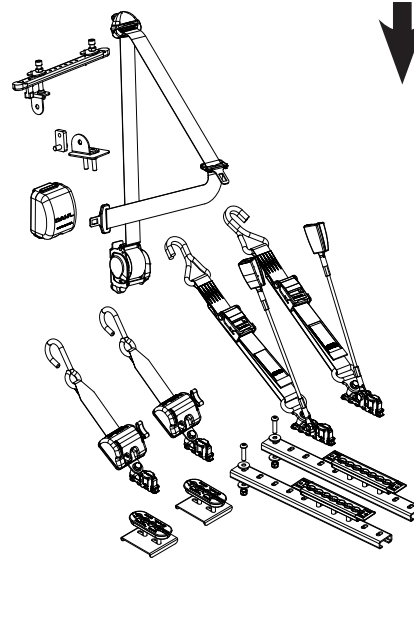
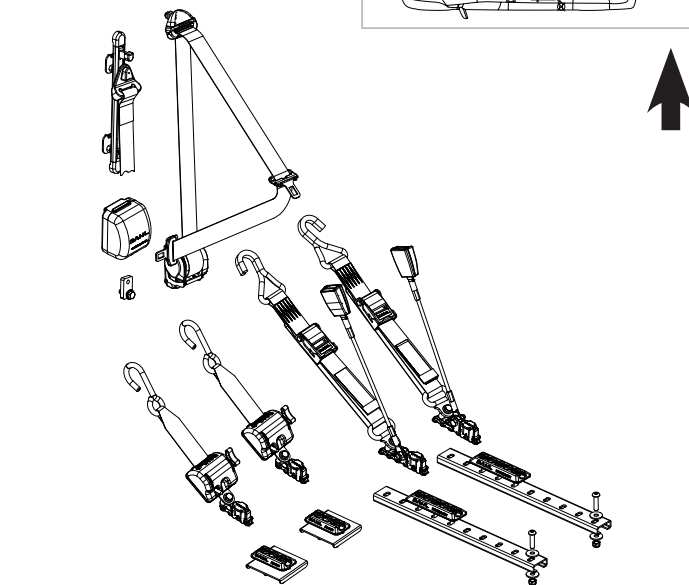
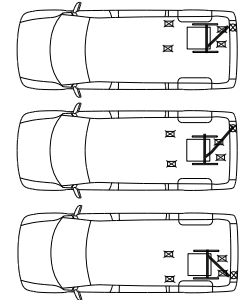

Art. nr. 503300
Citroën Jumpy / Space Tourer K0
MB Vito/V-Class W639 & 447
Opel Zafira Life
Peugeot Expert / Traveller K0
Toyota Proace / Verso 2016-
VW T5& T6

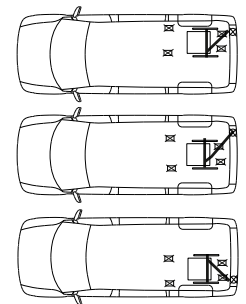

Art. nr. 503464
Tripod/Allied Drop Floor Conversion:
Citroën Berlingo
Peugeot Partner

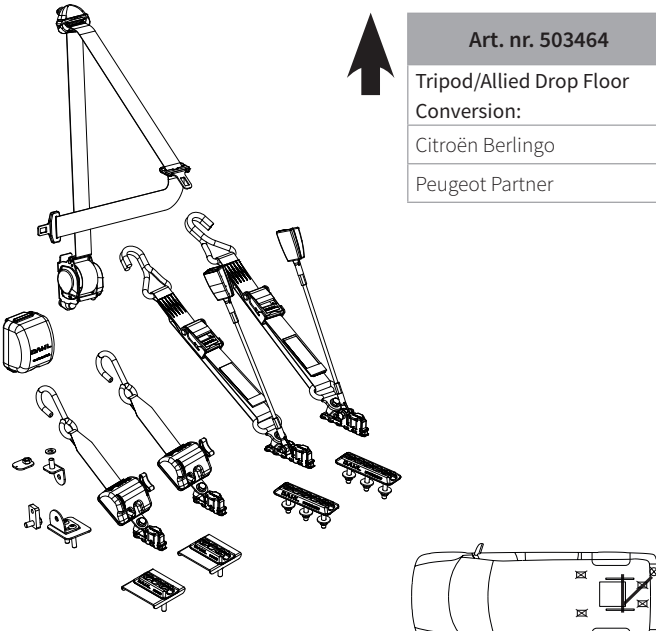

Art. nr. 503472
Citroën Jumpy / Space Tourer K0
Opel Zafira Life
Peugeot Expert / Traveller K0
Toyota Proace / Verso 2016-

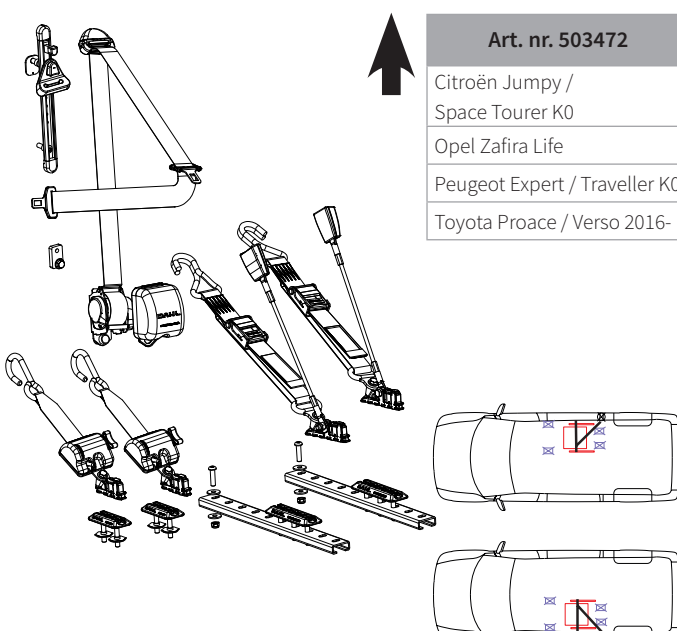

Sæt med 4 punkt WTORS - HEAVY DUTY Line 200 kg

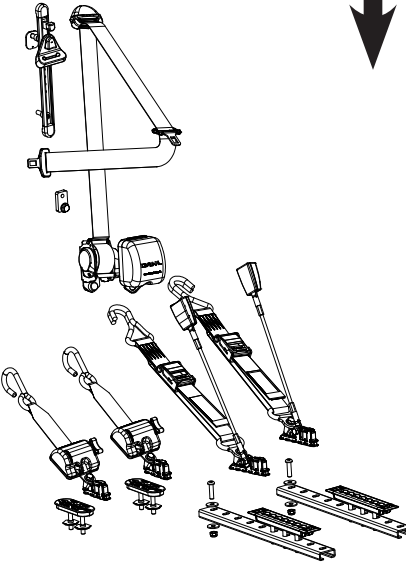

↓

Art. nr. 503474
Citroën Jumpy / Space Tourer K0
Opel Zafira Life
Peugeot Expert / Traveller K0
Toyota Proace / Verso 2016-

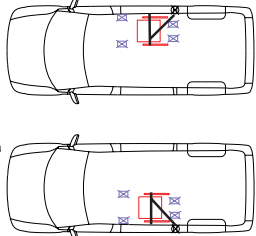

Art. nr. 503488
Fiat Talento X82
Ford Transit Custom V362
Man TGE 2017 - -
MB Sprinter 906, 907 & 910
Nissan NV300 & NV400
Opel Movano X62
Opel Vivaro X82 & X83
Renault Master X62
Renault Traffic X82 & X83
VW Crafter 2017-
VW T5 & T6

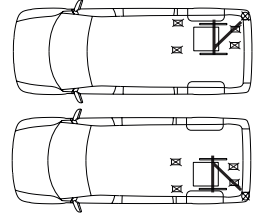

Art. nr. 503488
Citroën Jumper Y
Fiat Ducato X250
Fiat Talento X82
Ford Transit Custom V362
MB Sprinter 906, 907, 910
MB Vito V-Class W639 & W447
Nissan NV300 & NV400
Opel Movano X62
Opel Vivaro X82 & X83
Peugeot Boxer Y
Renault Master X62
Renault Traffic X82 & X83
VW T5 & T6

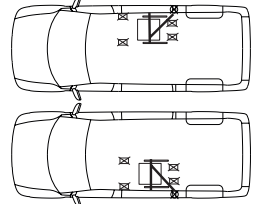

↓

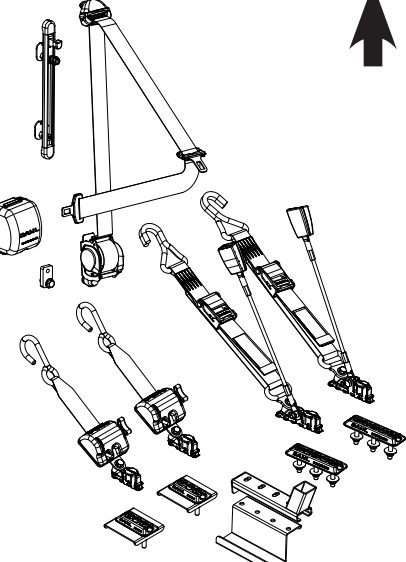

↑

Art. nr. 503479
GM Coachwork drop floor conversion:
VW Caravelle SE Colorado

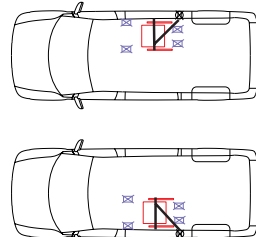
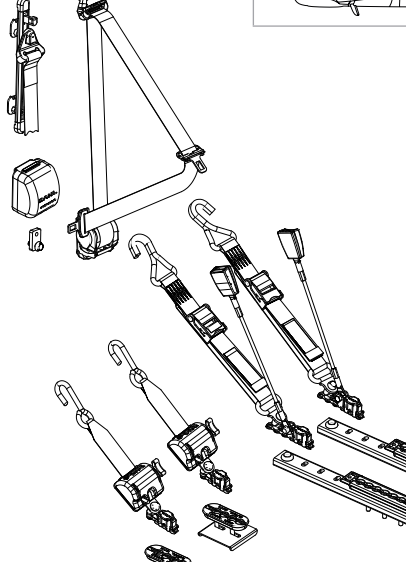
↓

Art. nr. 503494
Man TGE 2017 -
VW Crafter 2017-

↓

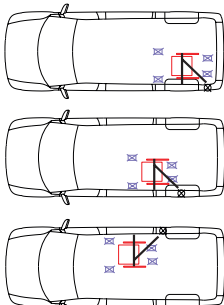
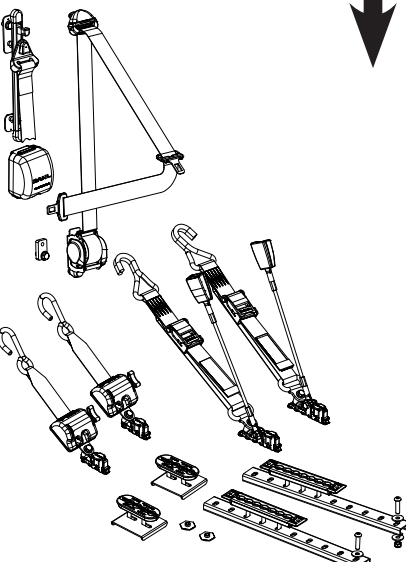
Art. nr. 503493
Man TGE 2017 -
VW Crafter 2017-



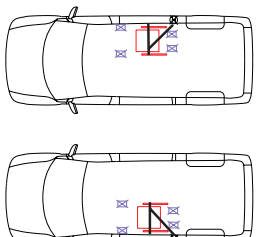
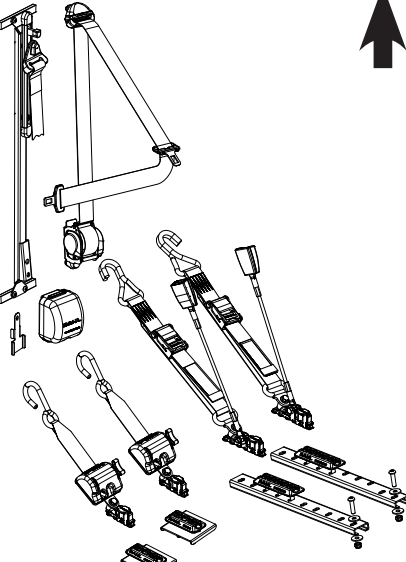

↑

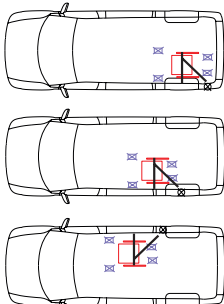
Art. nr. 503494
Man TGE 2017 -
VW Crafter 2017-

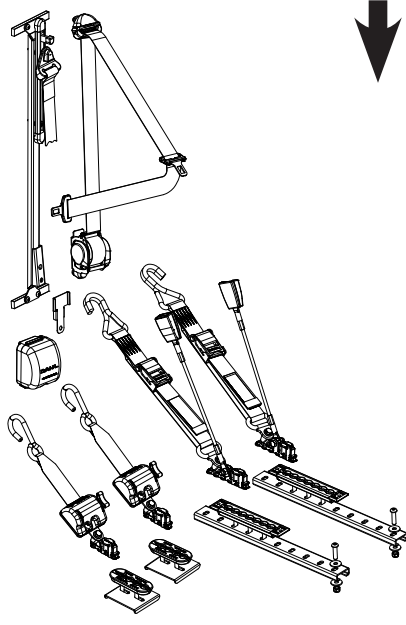

Sæt med 4 punkt WTORS - HEAVY DUTY Line 200 kg



Art. nr. 503495
 Man TGE 2017 -
 VW Crafter 2017-

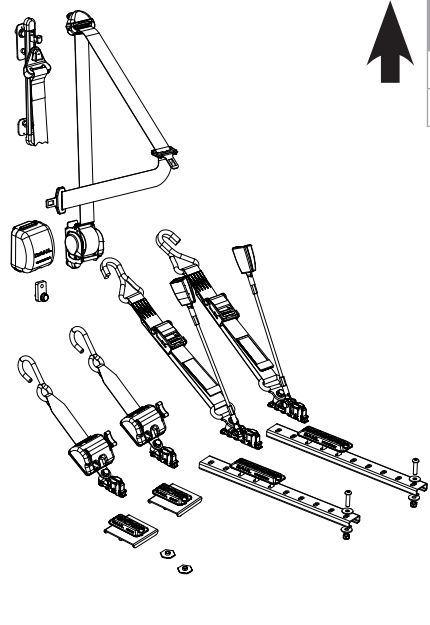
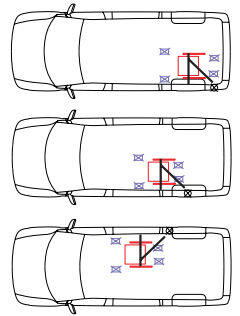

Art. nr. 503496
 Man TGE 2017 -
 VW Crafter 2017-

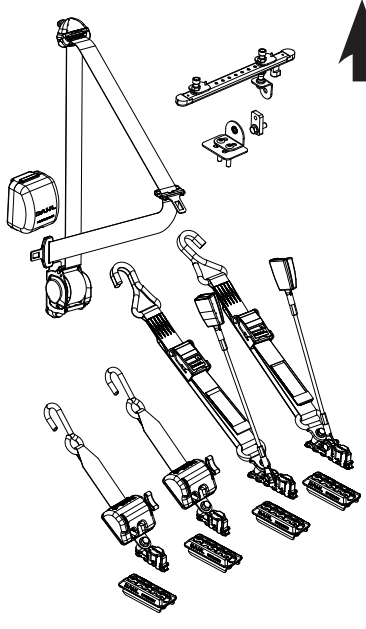
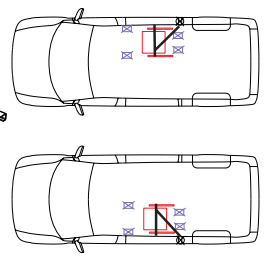

Art. nr. 503498
 VW T5/T6
 Multi Van & California
 Standard roof height with
 original VW floor rails

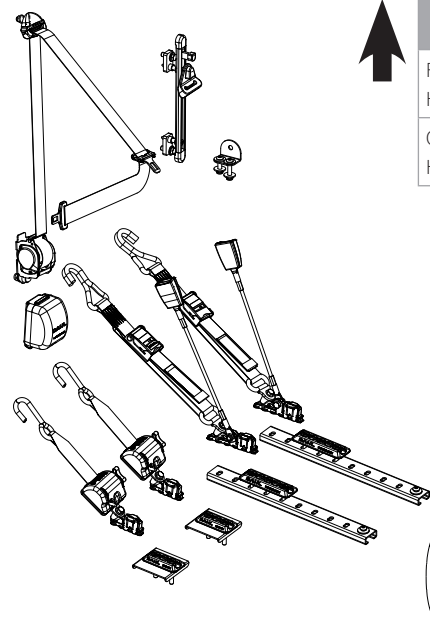
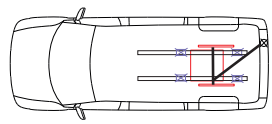

Art. nr. 503560
 Fiat Doblo
 High roof SWB & LWB
 Opel Combo
 High roof SWB & LWB

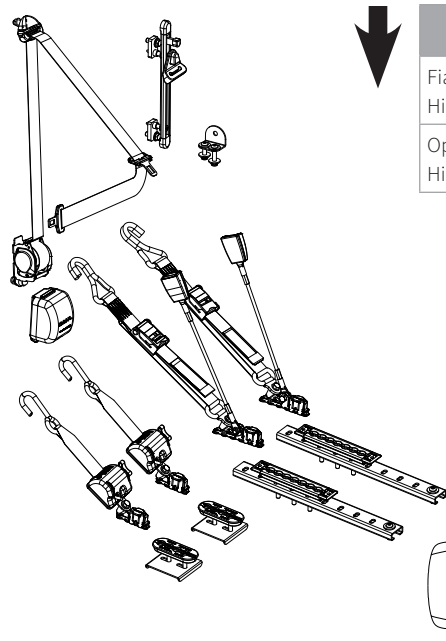
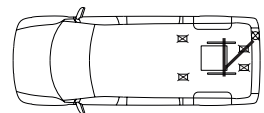

Art. nr. 503562
 Fiat Doblo
 High roof SWB & LWB
 Opel Combo
 High roof SWB & LWB

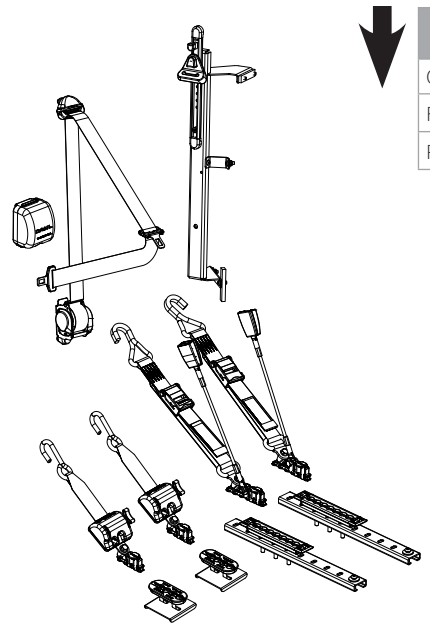
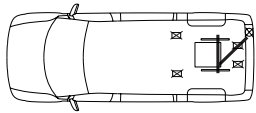

Art. nr. 503624
 Citroën Jumper Y
 Fiat Ducato X250
 Peugeot Boxer Y

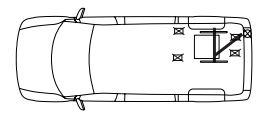

Sæt med 4 punkt WTORS - HEAVY DUTY Line 200 kg

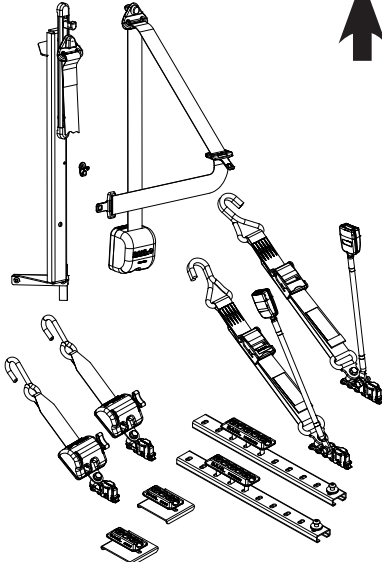

↑

Art. nr. 503604
Citroën Jumper Y
Fiat Ducato X250
Peugeot Boxer Y

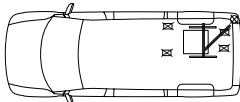
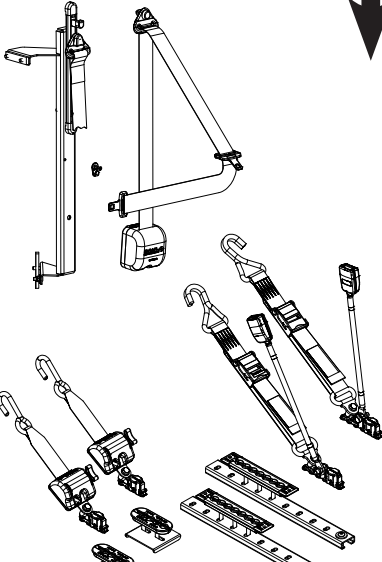
↓

Art. nr. 503605
Citroën Jumper Y
Fiat Ducato X250
Peugeot Boxer Y

↑

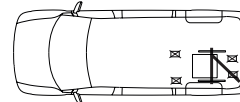
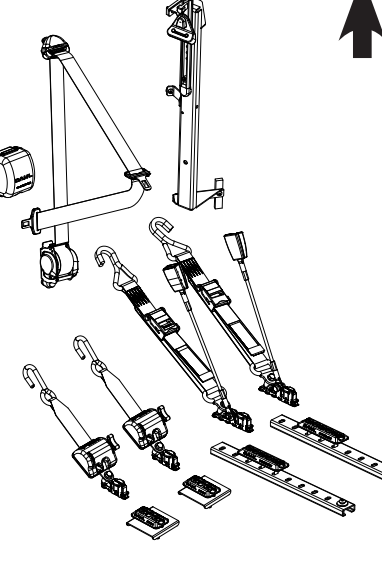
Art. nr. 503625
Citroën Jumper Y
Fiat Ducato X250
Peugeot Boxer Y

↑

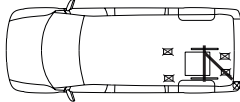
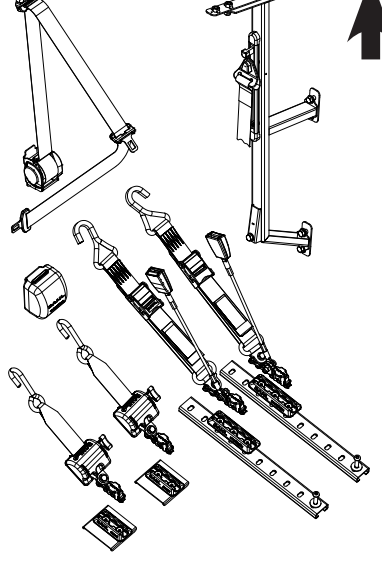
Art. nr. 500118
MAN TGE 2017-
Mercedes Sprinter 907&910
VW Crafter 2006-2016
VW Crafter 2017-
HIGH ROOF ONLY

↓

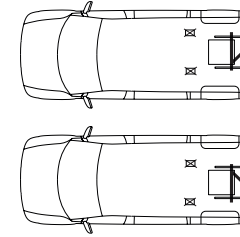
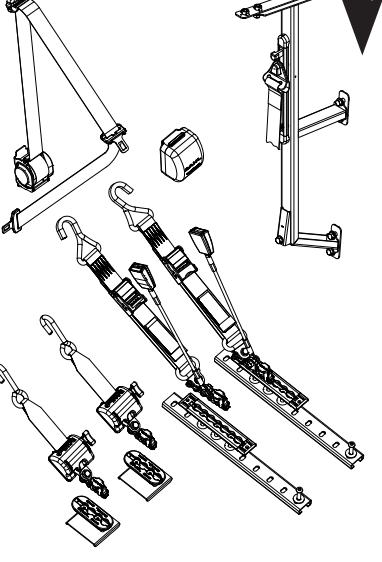
Art. nr. 500119
MAN TGE 2017-
Mercedes Sprinter 907&910
VW Crafter 2006-2016
VW Crafter 2017-
HIGH ROOF ONLY

↑

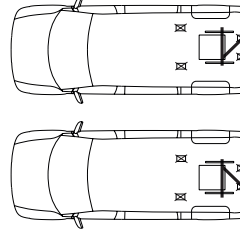
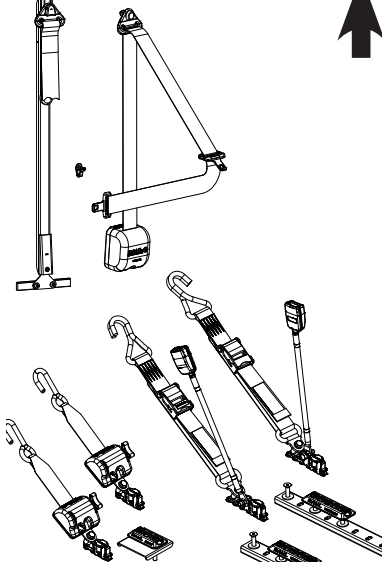
Art. nr. 500826
MB Sprinter 906, 907 & 910
VW Crafter 2006-2016

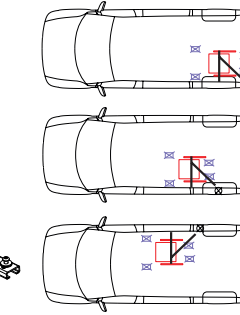

Reservedele: Sikkerhedsudstyr til kørestolsbrugere



Art. nr. 502379

EVOLUTION Line: 2 x #503158, 2 x #503157, 1 x #PN500984



Art. nr. 503311

EVOLUTION Line: 2 x #503411, 2 x #503412, 1 x #PN500984



Art. nr. 501533

CLASSIC Line: 2 x #501536, 2 x #501534, 1 x #PN500984

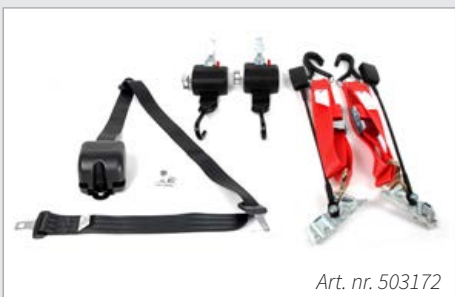

Art. nr. 503172

HEAVY DUTY Line 200kg. 2x #503157, 1x #502360, 1x #502361, 1x #PN500984



Art. nr. 503157

EVOLUTION Line: Fastspændingsretraktor - for.



Art. nr. 503158

EVOLUTION Line: Retraktor - bag.



Art. nr. 503412

EVOLUTION Line: Retraktor - for, til HEAVY DUTY skinne monteret på tværs



Art. nr. 503411

EVOLUTION Line: Retraktor, bag, til HEAVY DUTY skinne monteret på tværs



Art. nr. 503410

EVOLUTION Line: Retraktor-bag, med beslag til hofesele med karabinhage



Art. nr. 501536

CLASSIC Line: Retraktor - for



Art. nr. 501534

CLASSIC Line: Retraktor - bag



Art. nr. 502005

CLASSIC Line: Retraktor - for, til HEAVY DUTY skinne monteret på tværs



Art. nr. 502004

CLASSIC Line: Retraktor - bag, til HEAVY DUTY skinne monteret på tværs



Art. nr. 502384

HEAVY DUTY Line: Fastspændingsretraktor til 170 kg - venstre for



Art. nr. 502385

HEAVY DUTY Line: Fastspændingsretraktor til 170 kg - højre for

Reserve dele: Sikkerhedsudstyr til kørestolsbrugere



Art. nr. 503202

HEAVY DUTY Line: Fastspændingsretractor til 170 kg - venstre bag



Art. nr. 503201

HEAVY DUTY Line: Fastspændingsretractor til 170 kg - højre bag



Art. nr. 502360

HEAVY DUTY Line: Fastspændingsstrop til 200 kg - venstre bag



Art. nr. 502361

HEAVY DUTY Line: Fastspændingsstrop til 200 kg - højre bag



Art. nr. 501780

HEAVY DUTY Line: Fastspændingsstrop til 200 kg - venstre bag, uden selelås



Art. nr. 501781

HEAVY DUTY Line: Fastspændingsstrop til 200 kg - højre bag, uden selelås



Art. nr. PN500984

3-punkt sikkerhedssele



Art. nr. 500958

Statisk hoftesele



Art. nr. PN501761

90 mm ^[1]



Art. nr. PN501793

193 mm ^[1]



Art. nr. PN501794

300 mm ^[1]



Art. nr. PN501762

450 mm ^[1]



Art. nr. 501768

450 mm ^[1]



Art. nr. 502222

6-punkt skinnefitting, Heavy Duty

Reservedele: Sikkerhedsudstyr til kørestolsbrugere

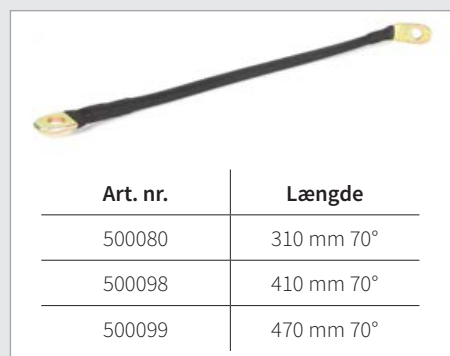

Fleksibel wire

Wire



Skinnefitting med gevind til 7/16" UNF bolt



Skinnefitting med 7/16" UNF gevind



Gulvbeslag i rustfri stål med Air Line hulmønster. Til montering ovenpå standard vognbund

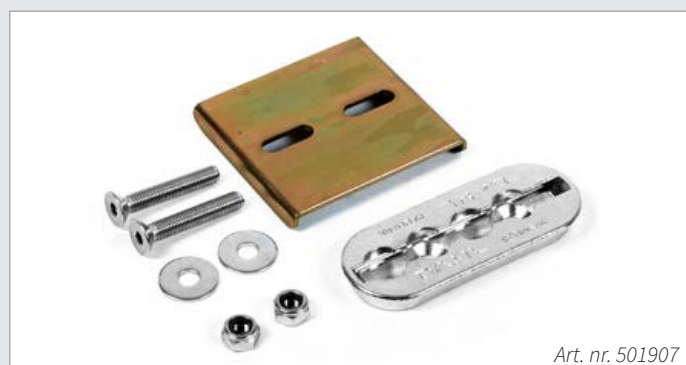

Gulvbeslag i rustfri stål med air-line hulmønster. Til undersænkning i vognbund



Heavy Duty gulvbeslag med montagekit



Heavy Duty gulvskinne til undersænkning med montagekit

Afdækning til seleslås



Art.nr. PN500095



Kender du problemet, at handicappede mennesker med særlige kognitive behov vil trykke på udløserknappen til sikkerhedssele lige så rask som man kan spænde den, når de skal spændes fast i bilen eller bussen?

Denne afdækning til seleslås sikrer, at brugeren forbliver sikkert fastspændt under hele køreturen.

Anordningen forhindrer at en person kan udløse selet, med mindre man anvender f.eks. en lille dorn, en nøgle eller en kuglepen, til at trykke på knappen gennem det lille hul i toppen.

Afdækningen kan anvendes sammen med de fleste bilers originale og godkendte sikkerhedssele, uden at det ville have indflydelse på selens virkning under en kollision.



ADVARSEL!

Dette produkt må udelukkende anvendes til en person med særligt behov og må kun finde sted efter særskilt ansøgning om tilladelse til brug hos Trafikstyrelsen.

Der følger en ansøgningsblanket med produktet.



Nyhed: Seleskærer til nødsituation er nu inkluderet.

Specialunderstel til originale passagersæder



Understel til originalt passagersæde, der giver ca. 10 cm mere plads til fødderne, når man skal dreje væk fra førerpladsen med en drejekonsol monteret.



Inde i understellet er der plads til det originale batteri eller andre elektriske komponenter.

Spørg venligst om det aktuelle leveringsprogram.



Art. nr. 500990
Understel til VW Transporter/ Caravelle T5 / T6



- Den originale passagerstol med glideskinner passer direkte i hullerne på understellet.
- Understellet er godkendt med seletåsen monteret på den originale passagerstol.
- Vi leverer en boltefærdig løsning, som gør, at man ikke behøver at skære, svejse eller bore i vognbunden for at kunne montere den.



Art. no. 502110
Understel til Mercedes Vito/V-Class W447

Fastspændingsudstyr til godssikring

Selvopstrammende
fastspændingsstrop



Verdens mest bekvemme
fastspændingsstrop

- Kan monteres permanent på køretøjet med en simpel enbolts montering eller anvendes mere fleksibelt med et skinne- eller beslag-system.
- Let enhåndsbetjening med indbygget skralde til låsning/opstramning.
- Selebånd kan trækkes 180 cm ud og ruller automatisk tilbage på rollen.
- 1550 kg brudlast
- Med rustfri stålfjeder og overfladebehandlet stål til at modstå korrosion.

Art. nr.: 500950 – CargoBuckle



Adaptore og tilbehør til godssikring

Adaptore giver større fleksibilitet og mobilitet for CargoBuckle, hvor permanent montering ikke ønskes



Vinkelbeslag

Kan monteres permanent i eksempelvis vognbunden eller siden af en trailer. 30° vinkelbeslag imødekommer langt de fleste monteringsituationer.

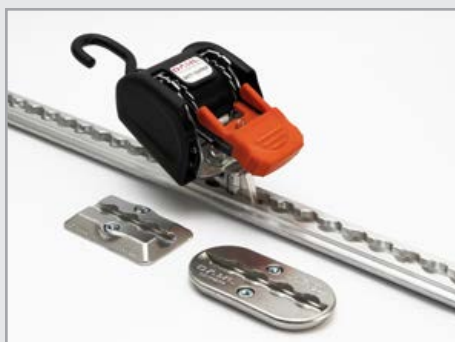

S-krog adapter

Vinyløverttrukket S-krog med sikringsbøjle giver CargoBuckle et sikkert forankringspunkt i eksempelvis en trailer eller last- og varebiler m.m.

Skinnefitting

Med skinnefitting kan CargoBuckle flyttes til en anden position eller helt fjernes. Skinnefittingen passer til gulvskinner med air-line hulmønster og Dahl's gulvbeslag. CargoBuckle monteret med skinnefitting er konstrueret, så den kan rotere til højre og venstre og derved drejes i retning af krogens monteringspunkt.

A



B



C



	Art. nr.	Beskrivelse
A	500957	S-krog adapter
B	501980	Vinkelbeslag - 30°
C	501845	Skinnefitting



Gulvbeslag i rustfri stål med Air Line hulmønster. Til montering ovenpå standard vognbund

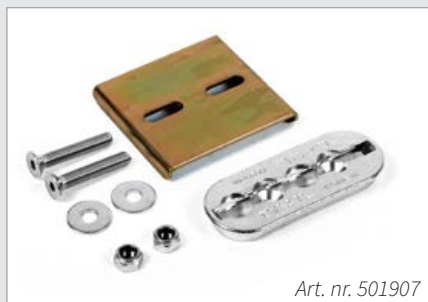

Gulvbeslag i rustfri stål med air-line hulmønster. Til undersænkning i vognbund



Dahl Heavy Duty gulvskinne

Salgs- og leveringsbetingelser

SALGS- OG LEVERINGSBETINGELSER for Dahl Engineering ApS & Maskinfabrik Dahl Engineering v/Claus Dahl Pedersen

01.01.2022

1.0 Aftalegrundlag

1.1 Enhver aftale og leverance sker i henhold til nærværende Almindelige Salgs- og Leveringsbetingelser.

2.0 Tilbud og Aftaleindgåelse

2.1 Acceptfrist for et af Dahl afgivet tilbud er 15 kalenderdage.

2.2 Endelig aftale om salg eller anden ydelse er først indgået ved Dahls afgivelse af skriftlig ordrebekræftelse.

2.3 Aftale anses for indgået på de i ordrebekræftelsen angivne betingelser såfremt køber ikke skriftligt har reklameret deroverfor senest 5 dage regnet fra modtagelsen.

2.4 Salgsmateriale, beskrivelser, vejledninger, prislister m.m. er alene af vejledende og uforbindende karakter.

3.0 Priser

3.1 Såfremt afgivne priser er baseret på udenlandsk valuta, reguleres prisen med (i) valutakursændringer, (ii) prisforhøjelser fra leverandører og (iii) ændringer i fragtrater, alt i perioden mellem afgivelse af tilbud og fremsendelse af faktura.

3.2 Ordre under DKK 800,- varekøb vil blive pålagt et ekspeditionsgebyr på DKK 125,-.

4.0 Levering og forsinkelse

4.1 Levering sker Ex Works Dahl i Thisted og forsendelse sker for købers regning og risiko.

4.2 Leveringstidspunkt fastsættes i Dahl's ordrebekræftelse.

4.3 Ved forsinkelse er Dahl's erstatningsansvar begrænset til købers dokumenterede direkte tab, og således eksklusiv mistet avance og andre indirekte tab og herudover maksimeret til 25% af købesummen for den forsinkede leverance.

5.0 Betaling

5.1 Første betaling fra nye købere skal ske forud. I det omfang køber kan kreditforsikres på normale vilkår er seneste rettidige betaling herefter 20 dage fra fakturadato. Ved betaling efter forfaldstidspunkt tilskrives rente 1,5% pr. påbegyndt måned.

5.2 Fakturaer, kontoudtog etc. fremsendes udelukkende i digital PDF-format til, den af køber oplyste e-mailadresse på Dahl Engineering's – Registreringsformular for nye kunder.

6.0 Ejendomsforbehold

6.1 Dahl bevarer ejendomsretten til det solgte, indtil den fulde købesum er erlagt.

7.0 Reklamation og mangler

7.1 Køber skal straks efter fremkomst af varen til købers plads foretage fornødne undersøgelser af denne.

7.2 Såfremt køber vil påberåbe sig mangler ved leverancen, skal køber straks manglen er eller burde være opdaget give Dahl skriftlig underretning herom, idet underretningen skal indeholde en specificeret angivelse af, hvori de pågældende mangler består. Undlader køber reklamation som anført, kan køber ikke senere gøre manglerne gældende.

7.3 Under alle omstændigheder skal reklamation fremsættes skriftligt overfor Dahl senest 6 måneder efter varens levering, og køber kan således ikke gøre mangler gældende i tilfælde af senere reklamation.

8.0 Ansvarsbegrænsning

8.1 I tilfælde af, at der måtte foreligge ansvarspådragende fejl eller mangler ved de af Dahl leverede produkter, er Dahl's ansvar begrænset til afhjælpning, såfremt manglerne kan afhjælpes herved og/eller omlevering eller betaling af erstatning maksimeret til fakturabeløbet, efter Dahl's valg.

8.2 Dahl er således ikke, i videre omfang end ovenfor anført, pligtig at erstatte nogen form for yderligere direkte eller indirekte tab, herunder driftstab og mistet avance.

8.3 Dahl ifalder i intet tilfælde ansvar, såfremt monteringsvejledninger og øvrige vejledninger og instruktioner ikke er overholdt, eller hvis produkterne er monteret i køretøjer, der ikke på monteringsstidspunktet af Dahl er godkendt hertil.

9.0 Produktansvar

9.1 Dahl's erstatningsansvar for personskade kan aldrig overstige det til enhver tid i henhold til dansk ret gældende erstatningsniveau.

9.2 Dahl's produktansvar ved tingsskade er beløbsmæssigt maksimeret til kr. 1.000.000,- pr. skadestilfælde. Et skadestilfælde defineres som alle beskadigelser, der er forårsaget af samme fejl eller forsømmelse. Den beløbsmæssige maksimering finder dog ikke anvendelse i tilfælde af grov uagtsomhed udvist af Dahl.

9.3 Dahl er ikke ansvarlig for drifts- og avancetab eller for andre indirekte tab.

9.4 Dahl ifalder i intet tilfælde et produktansvar, såfremt monteringsvejledninger og øvrige vejledninger og instruktioner ikke er overholdt, eller hvis produkterne er monteret i køretøjer, der ikke på monteringsstidspunktet af Dahl er godkendt hertil.

9.5 I den udstrækning Dahl måtte blive pålagt produktansvar overfor tredjemand er køber forpligtet til at holde Dahl skadesløs i samme omfang, som Dahl's ansvar er begrænset efter nærværende salgs- og leveringsbetingelser.

9.6 Såfremt tredjemand rejser sag vedrørende produktansvar mod enten Dahl eller køber er parterne gensidigt forpligtede til at underrette hinanden herom, ligesom parterne er gensidigt forpligtede til at lade sig sagsøge ved den domstol, hvor der er rejst sag mod en af parterne involverende påstået produktansvar vedr. de af Dahl solgte produkter, ligesom tilsvarende parternes indbyrdes forhold kan afgøres ved nævnte domstol.

10.0 Intellektuelle rettigheder

10.1 Dahl kan ikke overfor køber ifalde ansvar for krænkelse af tredjemands rettigheder. I tilfælde af krænkelse er Dahl berettiget til (i) ændring, omlevering uden forringelse af vares formål og ydeevne, (ii) tilbagekøb af varerne til faktura-pris, med fradrag for forringelse, eller (iii) udvirke ret for køber til fortsat anvendelse. Køber skal underrette Dahl om alle sådanne krav, og i det omfang kravet har konsekvenser for Dahl, er Dahl berettiget til at føre sagen på egne og købers vegne.

11.0 Returvarer

11.1 Leverancer vil kun rent undtagelsesvist og kun efter aftale kunne returneres. Varer der måtte være specielt produceret til eller hjemtaget til køber kan i intet tilfælde returneres.

11.2 Godkendte returvarer vil blive krediteret med fradrag af 20% af salgspris ekskl. moms ved franko levering, i uskadt stand, til Dahls lager eller anden af Dahl anvist plads.

12.0 Force majeure

12.1 Dahl er ansvarsfri for en ellers ansvarspådragende manglende kontraktmæssig opfyldelse af aftalen, såfremt dette er begrundet i arbejdskonflikt, brand, krig, militærindkaldelser, beslaglæggelse, valutarestriktioner, mangel på transportmidler eller andre lignende omstændigheder, som Dahl ikke med rimelighed kunne forudse på tidspunktet for aftalens indgåelse, herunder at nævnte eller lignende forhold rammer de af Dahl anvendte underleverandører.

13.0 Lovvalg og værneting

13.1 Alle tvister mellem Dahl og køber skal afgøres ved retten i Holstebro, henholdsvis Vestre Landsret, og under anvendelse af dansk ret.

13.2 Dog er Dahl berettiget til at vælge, at tvister i stedet skal afgøres ved voldgift ved Voldgiftsinstituttet efter de regler, der er gældende ved voldgiftssagens indledning.

WHERE SAFETY STARTS

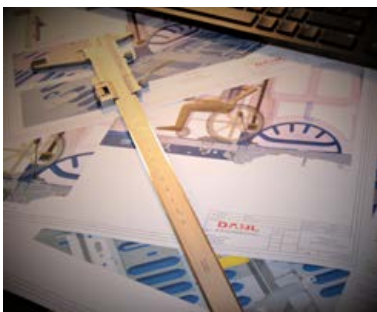
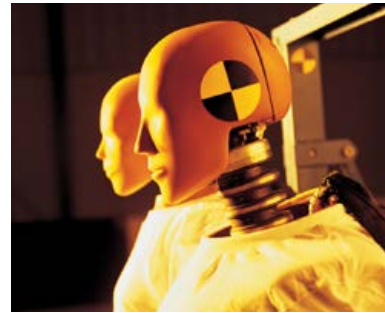

Foto*: Side, 1+30 - ACA France

Tilde Grafisk



Development and crash-test centre
Where safety starts

Dahl Engineering ApS | Løvevej 3 | DK-7700 Thisted | Danmark | Telefon: +45 9618 0077
e: sales@dahlengineering.dk | w: wtors.com