

# Karma

*User manual*

## *Morgan M (MGNM)*

- Sling Seat (SLN)
- Versus Seat (VRS)



A Better Wheelchair, A Better Fit

## 1. Index

1. Index	2
2. How to contact Karma	7
3. Declaration of conformity	8
4. Introduction	10
4.1 Chassis number	10
5. Used symbols for warning, caution and note	12
6. Warranty	13
7. Intended use / intended user	14
8. Intended environment	14
9. Tire pressure	15
10. The wheelchair	15
10.1. Chassis	15
10.1.1 Chassis suspension	15
10.1.2 Lights and reflectors (Optional)	16
10.1.3 Transport fixation loops	17
10.1.4 Battery compartments	17
10.1.5 Main fuse	19
10.2 Seat	20
10.2.1 Upholstered seat cushion	20
10.2.2 Seat tilt (Optional)	20
10.2.3 Upholstered backrest	21
10.2.4 Backrest	21
10.2.5 Armrest	23
10.2.6 Footrest	23
10.2.7 Contoured headrest (Optional)	24
10.2.8 Positioning belt	24
10.3 The controls	25

10.3.1 Side control _____	25
10.4 Other optional accessories _____	26
11. First setup _____	27
11.1 Chassis suspension _____	27
11.1.1 Spring setting _____	27
11.2 Seat adjustments _____	29
11.2.1 Seat depth _____	29
11.2.2 Backrest (seat-to-back) angle _____	31
11.2.3 Armrest width: _____	31
11.2.4 Armrest height _____	32
11.2.5 Armrest depth _____	33
11.2.6 Footrest longitudinal position _____	34
11.2.7 Footrest length _____	35
11.2.8 Headrest setting _____	36
11.3 Positioning belt _____	37
11.4 Control settings _____	38
11.4.1 Depth adjustment side control _____	38
11.4.2 Height adjustment side control _____	38
12 Joystick _____	39
12.1 Charging socket _____	39
12.2 Joystick _____	39
12.3 Control panel _____	40
12.3.1 Battery indicator _____	41
12.3.2 On/Off button _____	41
12.3.3 Horn button _____	42
12.3.4 Speed Indicator _____	42
12.3.5 Speed decrease/ increase button _____	42
12.3.6 Seat position indicator _____	42
12.3.7 Seat position button _____	42

12.3.8 Hazard warning button _____	42
12.3.9 Lights button _____	43
12.3.10 Left/ Right Indicator button _____	43
12.3.11 Wheelchair lock _____	43
12.3.12 Joystick deflected error _____	44
13 Electric system _____	45
13.1 Batteries _____	45
13.2 Main Fuse _____	46
14 Using the wheelchair _____	47
14.1 General warnings and advices _____	47
14.2 Use in combination with other products _____	48
14.3 Hot and cold surfaces _____	48
14.4 Danger of pinching _____	49
14.5 Surroundings _____	50
14.6 Precautions to prevent dangerous situations _____	50
14.7 Use on slopes: driving on downhill slopes _____	51
14.8 Use on slopes: driving on uphill slopes _____	52
14.9 Driving on sideways slopes _____	54
14.10 Obstacle climbing _____	55
14.11 Use in presence of electromagnetic fields, e.g. from cell phones. _____	56
15 Driving the wheelchair _____	57
15.1 Driving in general _____	57
15.2 Driving technique _____	58
15.3 Stopping the wheelchair _____	59
16 Using the powered seat functions _____	59
16.1 Seat tilt/ Backrest recline _____	59
17 Handling the mechanical brakes _____	60
17.1 Release the mechanical brakes _____	60
18 Charging the maintenance free batteries _____	62

18.1 Battery level _____	62
18.2 Charging socket _____	63
18.3 Disposal of broken or worn out batteries _____	65
19 Transport of the wheelchair _____	66
19.1 4-point Tie-down belts _____	66
19.1.1 Safety belt: _____	68
19.1.2 Backrest, legrest and headrest settings during transportation _____	72
19.2 Transportation on an airplane _____	72
19.2.1. Batteries _____	73
19.2.2. The wheelchair's dimensions and weight _____	73
19.3 Transportation using Dahl Docking station _____	74
19.3.1 Mounting of the Dahl locking adapter on the wheelchair _____	75
19.3.2 Locking procedure _____	80
19.3.3 Unlocking procedure _____	81
19.3.4 Manually unlocking in case of electric failure or accident _____	82
19.3.5 Safety belt _____	83
19.3.6 Positioning the occupant restraint when using it with the Dahl Docking systems only _____	86
20. Maintenance and repairs _____	86
20.1 Battery charging _____	87
20.2 Short term storage _____	87
20.3 Long term storage _____	87
20.4 Tools _____	89
20.5 Wheels and tires _____	90
20.5.1 Puncture repair _____	90
20.6 Cleaning _____	91
20.6.1 Upholstery, cloth / air mesh _____	91
20.6.2 Metal surfaces _____	92
20.6.3 Plastic covers _____	92

20.7 Brake release, freewheel mode _____	92
20.8 Battery replacement _____	93
20.8.1. Replacing the batteries (Front side) _____	94
20.8.2 Replacing the batteries (Rear side) _____	96
20.8.3 Disposal of the batteries _____	98
21 Refurbishment and re-use of the product. _____	99
22 Disposal of the product _____	99
23 Trouble shooting _____	100
23.1 Diagnostics VR2 _____	101
24 Technical specifications _____	103
25 Accessories _____	105

## 2. How to contact Karma

### Head office Karma

# Karma

Karma Medical  
NO.2363, Sec. 2  
University Road  
Min-Hsiung Shiang  
Chia-Yi 621  
Taiwan  
[www.karmamedical.com](http://www.karmamedical.com)

### European representative:

# Karma

Karma Mobility S.L.  
C/ Periodista Francisco Carantoña Dubert,  
23 Bajo 33209 Gijón - Asturias (Spain)  
phone: +34 984 390 907  
[karma@karmamobility.es](mailto:karma@karmamobility.es)

EC REP

**Karma Medical European representative:**

KARMA MOBILITY, S.L.

C/ PERIODISTA FRANCISCO CARANTOÑA DUBERT, 23 Bajo 33209 GIJÓN - ASTURIAS(SPAIN)

Tel: (+34) 984 390 907 E-mail : [karma@karmamobility.es](mailto:karma@karmamobility.es)

Produced and published by Karma Medical, Taiwan  
Technical changes and print errors prohibited.

### 3. Declaration of conformity



Document No.: DOC-MorganM-00

#### EU Declaration of Conformity

We, with the information specified in the below,

**Our information as the manufacturer:**

Manufacturer's Name:	KARMA MEDICAL PRODUCTS CO., LTD
Manufacturer's Address:	NO. 2363, Sec. 2, University Rd., Min-Hsiung Shiang, Chia-Yí County, 62144, Taiwan
SRN (Single Registration Number):	TW-MF-000013206

**Our authorized representative:**

Name:	KARMA MOBILITY, S.L.
SRN (Single Registration Number):	ES-AR-000004852
Address:	C/ PERIODISTA FRANCISCO CARANTOÑA DUBERT, 23 Bajo 33209 GIJÓN – ASTURIAS, SPAIN
Contact Person:	Raquel Yuste
Contact Information:	(+34) 984 390 907

in accordance with

**Regulation (EU) 2017/745 of the European Parliament and of the council Annex I, II, III, IV and IX**

hereby declare that the medical device specified below:

<b>Basic UDI-DI of Annex VI:</b>	471987385MorganM9Z
<b>Device:</b>	Electrically powered wheelchair
<b>Trade Name or Mark:</b>	Morgan M (MGNM)
<b>Model Number:</b>	MGNM-SLN MGNM-VRS
<b>Product Code according to EMDN:</b>	Y122127
<b>Product Code according to GMDN:</b>	41877
<b>Classification:</b>	Rule 1 of Class I
<b>UDI-DI:</b>	04719873856800 04719873856817



is in conformity with the applicable requirements of the following documents:

Ref. No.	Title	Edition date
ISO 13485	Medical devices - Quality management systems - Requirements for regulatory purposes	2016
ISO 14971	Medical devices - Application of risk management to medical devices	2019
EN 12182	Assistive products for persons with disability - General requirements and test methods	2012
EN 12184	Electrically powered wheelchairs, scooters and their chargers - Requirements and test methods	2014
EN 62366	Medical devices - Application of usability engineering to medical devices	2015
EN 60601-1	Medical electrical equipment - Part 1: General requirements for basic safety and essential performance	2006
EN ISO 10993-1	Biological evaluation of medical devices - Part 1: Evaluation and testing within a risk management process	2009
EN ISO 10993-5	Biological evaluation of medical devices — Part 5: Tests for in vitro cytotoxicity	2009
EN ISO 15223-1	Medical devices - Symbols to be used with medical device labels, labelling and information to be supplied - Part 1: General requirements	2016
MEDDEV. 2.7/1 Rev. 4	CLINICAL EVALUATION: A GUIDE FOR MANUFACTURERS	2016
MEDDEV 2.12/1 Rev. 8	GUIDELINES ON A MEDICAL DEVICES VIGILANCE SYSTEM	2013

The information on this declaration has been stated on the sole responsibility of KARMA MEDICAL PRODUCTS CO., LTD.

We hereby declare that the device named above has been designed to comply with the relevant sections of the above referenced specifications. The device complies with all General Safety and Performance Requirements.

Date of issue: 11<sup>th</sup> April 2022

Place of issue: NO. 2363, Sec. 2, University Rd., Min-Hsiung Shiang, Chia-Yi County, 62144, Taiwan



Richard Chang, CEO

## 4. Introduction

Congratulation with your new Karma product! This product has been made with great care and dedication. The Karma product will increase your freedom of mobility and independence. Karma and it resellers all over the world are there to support in any way. So if you have questions or suggestions about our products, do not hesitate to get in contact with us at [globalsales@karma.com.tw](mailto:globalsales@karma.com.tw).

Before you use the Karma product, we strongly recommend you read this manual carefully and always keep it with your product. This way you are always able to find additional information when needed.

Karma runs the policy of continuously product improvement. Therefore, pictures of products or options as shown in this manual might be different from what you see in the product. Karma reserves the right to make changes to the product without prior notice.

### 4.1 Chassis number

The chassis number is a very important. Your wheelchair will be stored in our data system under this main number. You can find the number on the right front of the chassis.

	<b>Karma Medical Products Co., Ltd.</b> 2363, Sec. 2 University Rd., Min-Hsiung, Chia-Yi 621, Taiwan	
TYPE	<input type="checkbox"/> Morgan M Sling (MGNM-SLN) <input type="checkbox"/> Morgan M Versus (MGNM-VRS)	
V <sup>max.</sup>	<input type="checkbox"/> 6 km/h <input type="checkbox"/> 10 km/h <input type="checkbox"/> 12 km/h	
 136 kg	<input type="checkbox"/> 6° <input type="checkbox"/> 8°	<input type="text" value="SN"/>
		<input type="text" value="MD"/>

Chassis serial plate



The used symbols on the chassis plate are explained below:



describes the model and type of the product.



stands for indoor- and outdoor use (Class B).

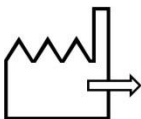

stands for the date of production.



this icon stands for the maximum driving speed.



this icon stands for the maximum slope to drive on.



this icon stands for the maximum user weight.

**SN:**

stands for the chassis serial number.

## 5. Used symbols for warning, caution and note

General warnings are indicated by a symbol. There are three levels of warnings:

### 1. Warning



If you see this sign, please use extreme caution where this symbol appears. Neglecting these warnings can lead to personal or material damage.

### 2. Caution



If you see this symbol, use caution to prevent dangerous situations.

### 3. Note



If you see this symbol we provide additional information which might be good to know. Please take notice if this information.



- Before using the wheelchair, you should read this manual to get familiar with this product.
- Make sure the local reseller has set up the product in a proper way to exactly fit your needs and requirements.
- Always be accompanied by an attendant person when you drive the wheelchair for the first time.
- The first drive should take place in a safe and wide area so you can get acquainted to your wheelchair without any danger.
- Always start to drive the wheelchair in the lowest possible driving speed first.

## 6. Warranty

Karma Medical supplies a warranty of frame for a period of 5 years and electrical system (controller, motor, charger, actuator and PCB) for a period of 1 year after delivery to the customer. Your local supplier will carry out this warranty. For battery warranty, it is subject to the periods set by the manufacturers. Please contact your local supplier in detail.

For a warranty claim you get in contact with our local authorized Karma reseller or directly with Karma Mobility S.L. Make sure you also provide the chassis serial number of your product.

The warranty does not apply to damage or faults of the product caused by wrong or improper use, or neglected maintenance. The evaluation of it is the privilege of Karma Medical or a representative to be appointed by Karma Medical.

This guarantee does not apply to components susceptible to wear such as bearings, cables, carbon brushes, circuit breakers, covers, footplates, light bulbs, pads, side guards, upholsteries, wheels and similar parts.

Karma Medical reserves the right to alter the specifications at any time. No responsibility can be accepted for any changes in the specifications. Change of specification can be caused by e.g. availability of parts, product improvement based on market experience, changed legislations etc.

Besides, Karma Medical is not responsible for the transportation costs for repair and replacement.



### WARNING

The use of non-original parts on this product can lead to personal or material damage. Karma Medical cannot be held responsible for these results.

Repairs executed by unauthorized persons can lead to personal or material damage. Karma Medical cannot be held responsible for these results.

If you have any doubt about the service provided to your wheelchair, please contact Karma Medical Taiwan for information.

## 7. Intended use / intended user

The Morgan M Sling (MGNM-SLN) powered wheelchair is meant to provide mobility to persons who are not able to walk, stand or use a manual wheelchair, but who are very well able to control and use the interface of a powered wheelchair. The wheelchair is designed for a maximum user weight of 136 kg.

It is strongly suggested to have the use of the wheelchair evaluated by a trained doctor, therapist or other qualified and trained staff.

This wheelchair is not suitable for persons who do not have the cognitive skills to drive a powered wheelchair by themselves. Also, it is not suitable for visually impaired persons.

The expected service life of the product is **five years**, presuming that the product is used daily in accordance with the safety operation instructions, inspection and maintenance instructions, and intended use, which described in this manual.

## 8. Intended environment

The Morgan M Sling (MGNM-SLN) powered wheelchair is not restricted to only indoor or only outdoor use. Because the driving wheels are placed in the middle, the wheelchair is extremely maneuverable and is able to cope with many terrain differences. This, combined with the compact size of the product and the excellent speed range and battery capacity, making the wheelchair suitable for both indoor and outdoor use.

It is allowed to use the wheelchair in different weather conditions. It can be used at temperatures of -25 degrees up to maximum 55 degrees Celsius and the charger operate temperatures is 0 up to 40 degrees Celsius. However, it must be noticed that metal or plastic surfaces of the wheelchair can become very hot when exposed to direct sun for longer time.

Because of the harmful combination of saltwater and sand, it is advised not to use the wheelchair on beaches. We advise to clean the wheelchair after having been in contact with sand and/or saltwater as described in the paragraph "cleaning".

## 9. Tire pressure

The Morgan M Sling (MGNM-SLN) uses solid or air-filled tires in the front and middle and solid tires in the rear. The choice of having solid or air-filled tires is made by the user during the ordering of the wheelchair. In order to prevent tire damage and to preserve the performance of the wheelchair, the tire pressure must be checked at least on a monthly basis. The tire pressure should be:

**Front air-filled tires (small): max. 275 Kpa / 40 PSI / 2.8 bar**

**Middle air-filled tires (large): max. 240 Kpa / 35 PSI / 2.4 bar**

## 10. The wheelchair

### 10.1. Chassis

The chassis is the base of the wheelchair. It contains wheels, drive motors, batteries and electronics. The steel parts of the chassis are electrolytic anodized and powder coated to ensure a long life without corrosion.



Each of the middle wheels is propelled by a powerful drive motor. These motors also take care for the steering of the wheelchair. With this system it is possible to turn on the spot. This makes the wheelchair optimal for indoor use.

#### 10.1.1 Chassis suspension

The chassis has independent suspension on each of the six wheels. The stiffness can be adjusted to your personal requirements.



*Front suspension*

*Rear suspension*

### 10.1.2 Lights and reflectors (Optional)



The chassis has very strong and bright LED lights to make sure you can have a safe drive in the dark. The red reflectors in the rear also make you visible for other people as well. The lights fulfill the European requirements. The additional LED indicators give our environment clear information in which direction you want to go.



### 10.1.3 Transport fixation loops

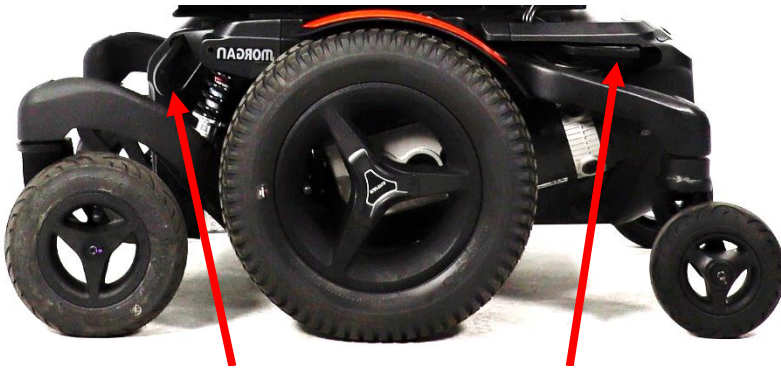

*Fixation loops in the front      Fixation loops in the rear*

The fixation loops are marked with this sign:

Further information about transportation of the wheelchair will find in chapter "transportation".



### 10.1.4 Battery compartments

The batteries are mounted as low as possible in the center into the chassis, to provide an optimal center point of gravity. This results in a maximum stability of the wheelchair. The compartment can hold maintenance-free batteries up to 80Ah. For the specification of the batteries see the chapter technical specifications.

The maintenance-free batteries can be reached from the front and rear sides. They can be replaced whilst the user is still in the wheelchair.

For more details of changing the batteries, please check the paragraph "battery replacement".



*Front battery box*

**⚠ CAUTION**

When pulling the battery out of the box, do mind to not overstretch the cables. This might lead to technical failure.

**⚠ CAUTION**

Before reconnecting the battery, read the wiring instructions on the inside of the battery cover.

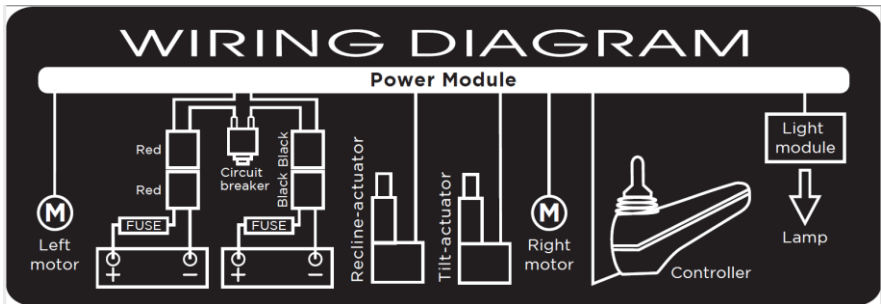

### 10.1.5 Main fuse

The chassis contains a circuit breaker which is located at the front of the chassis. The circuit breaker protects the whole electrical system of the wheelchair. This circuit breaker will only blow if there is a serious problem on the wheelchair.



*Position of circuit breaker*

This situation happens typically when the wheelchair is climbing up a hill that is steeper than what is restricted. Should the circuit breaker pop-up, you need to eliminate the cause first. And then, press down the circuit breaker. You will be able to drive again.

 **CAUTION**

If the circuit breaker has blown, do not replace it immediately. First contact your local supplier to have the wheelchair checked.

 **CAUTION**

Only use original circuit breaker as replacement. Using other circuit breaker might lead to material damage to the wheelchair.

## 10.2 Seat

The Sling Seat can be adjusted in seat depth, seat-to-back angle, footrest length and hanger position, and armrest height. It can be up-graded into manual recline, power recline or power tilt. The seat pan is flat so other seating cushion can be fitted on to the seat as well.



### 10.2.1 Upholstered seat cushion

The Sling Seat upholstered seat cushion is available in different sizes to provide optimal seating comfort and support to the user. The cloth is air mesh. The seat cushion is well fixed with Velcro on to the seat pan to prevent it from sliding.

### 10.2.2 Seat tilt (Optional)

The seat tilt can be used to release pressure. The tilting angle is from 0 to 21°. The tilting function can also be used when driving down a slope for compensating the negative seat angle. This provides a more stable seat position and safe driving.



If the tilt is activated over a certain angle, the driving speed will be reduced. This is to reduce the risk of danger whilst driving at high speed.

 **CAUTION**

Always drive carefully on slopes. The angle of the slope has great influence on the total stability of the wheelchair.

 **CAUTION**

When tilting, always check if there are no obstructions close to the wheelchair. Especially in the front or rear of the wheelchair.

 **CAUTION**

When tilting, the wheelchair will get longer. This has influence on the driving characteristics of the wheelchair. Make sure there is enough space to drive.

### **10.2.3 Upholstered backrest**

The Sling Seat upholstered backrest is available in different sizes to provide optimal seating comfort and support to the user. The cloth is breathable fabric. The upholstered backrest is well fixed with Velcro on to the bottom backrest upholstery to prevent it from sliding.

### **10.2.4 Backrest**

#### **Angle adjustable backrest**

The Sling Seat backrest angle can be set from 91° / 94° / 97°/ 100°/ 103°/ 106°. By adjusting the position of knobs and nuts, you can set the backrest to the desired angle.

## Manual stepless recline backrest (Optional)



The mechanical adjustable recline backrest uses a stepless telescopic tube with quick release and lock lever action. The mechanical recline setting has the same dynamic angle setting as the power recline system.

## Power recline backrest (Optional)

The power recline backrest can be set from 90° to 122°. It gives the user the possibility to move into a laying position or a very active sitting position.



If the reclined backrest position is activated over a certain angle, the driving speed will be reduced. This is to reduce the risk of danger whilst driving at high speed.

### CAUTION

When reclining, always check if there are no obstructions close to the wheelchair. Especially in the rear of the wheelchair.

**CAUTION**

When reclining, the wheelchair will get longer. This has influence on the driving characteristics of the wheelchair. Make sure there is enough space to drive.

### 10.2.5 Armrest

The armrest pads are adjustable in height and depth. For transferring in and out of the chair, the armrests can be flipped up. Simply pull the flip-back lever, the armrest can be flipped backwards.



### 10.2.6 Footrest

The footrest can be swung away and detached for transportation or storage. The footrest can be adjusted in length and in depth.

To swing away and detach the footrests, pull the swing-away lever, then you can swing away and/or detach the footrests. It makes transferring in and out of the chair easier.



### 10.2.7 Contoured headrest (Optional)

The upholstered headrest is adjustable in height, depth and angle to the requirements of the user.



#### **i** NOTE

If the wheelchair user is transported in a taxi or public transportation, we strongly advise to use the headrest. This to provide you optimal stability whilst driving in the public transportation.

### 10.2.8 Positioning belt

The positioning belt provides sitting safety and positioning for users.



#### **i** NOTE

The positioning belt shall not be used as a car safety belt. If transported in a car, the user needs to wear an additional car safety belt.



## 10.3 The controls

### 10.3.1 Side control







*Side control*



*Side control, swing-away*

This wheelchair has a side control unit, which is either mounted on the left or right armrest. The joystick module can be mounted on a fixed bracket or an (optional) swing-away mechanism. This system enables you to sit close to access a table.

## 10.4 Other optional accessories

Item	Figure	Introduction
Handlebar		<p>The handlebar is to help user to stabilize upper body. It can be adapted after-sales.</p>
Elevating Legrest		<p>For those who need to elevate their legs or keep their legs at a certain angle. It can be adapted after-sales.</p>
Center-mounted Footrest		<p>The center-mounted footrest can create shorter total length of the chair and smaller turning radius. It can be adapted after-sales.</p>
Tray Table		<p>The tray table provides a platform for the user. It can be adapted after- sales.</p>

### CAUTION

The arrangement of the options / accessories should take the motion of wheel and cables into consideration, it is suggested to set up those options / accessories by an authorized Karma supplier.

## 11. First setup

Before using, the wheelchair needs to be adjusted and set up for the user. In this chapter we will explain all the setup which needs to be done before the first drive.

### CAUTION

Before using the wheelchair, it is vital to make the right setup for the user. A non-proper setup of the wheelchair might lead to uncontrolled driving which can result in personal or material damage.

### 11.1 Chassis suspension

The suspension of a chassis has been designed to increase the comfort whilst driving. Also climbing steps will be easier having suspension on the chassis. But suspension can also be a disadvantage. A suspension which is set to soft has a negative influence on the control of the wheelchair. So, it is very important to have a good mix.

#### 11.1.1 Spring setting

Each Morgan M Sling (MGNM-SLN) wheelchair chassis has two spring units in the front, middle and rear. The tension of the spring will be set by rotating the threaded ring which is compressing. By rotating the ring, you can either increase the tension (load), or reduce the tension of the spring. Increasing the tension on the spring, the wheelchair suspension becomes stiffer. This increases the mechanical traction and improves control.

The stiffness of the suspension can also depend on the user's weight. The settings need to be done by setting and testing. We advise you to start with a stiffer setting, since this results in the better control. If the suspension is too hard, you can set it softer by turning the ring more counterclockwise.

To make sure the balance of the left and right spring is the same, we need to measure the setting. The best way is to measure the distance between both rings where the spring is clamped in mm. Make sure that the spring settings between left and right are identical.

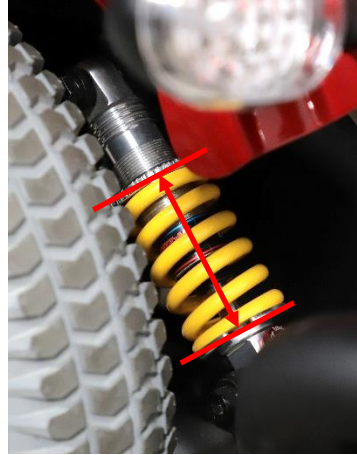

*Measure spring setting between left and right sides*

**⚠ CAUTION**

To soft settings of the spring will result in a very spongy behavior of the chassis. The control of the wheelchair will be bad. Avoid soft settings.

**⚠ CAUTION**

If the springs are uneven set, it might lead to strange driving behavior of the wheelchair. This might result in personal or material damage.

**i NOTE**

After setting the suspension, always drive first slowly and in an open space to test the result of the setting.

## 11.2 Seat adjustments

Before using the wheelchair, the seat must be set to the right size for the user. Most of the time this will be done by your local supplier, together with your therapist. A well-adjusted seat will give you optimum support and comfort.

### 11.2.1 Seat depth

To adjust the seat depth, we move the backrest frame forward or backward. Please take the following steps:

Step 1: First, take off the seat cushion. Use 4mm Allen key to unscrew the bolts connecting the seat plate. Then take off the seat plate.



Step 2: Use two #13 Open Wrench to remove these 4 bolts and nuts connecting the frame. There are holes for incremental adjustments which is in increments of 25.4 mm (1").



Step 3: Lift the seat and move it forward or backward to the desired position.



Step 4: Mount the bolts and nuts connecting the frame and tighten them up.



Step 5: Secure back the seat plate and put back the seat cushion.

**i NOTE**

The setting of the seat depth requires some expertise. Therefore we strongly advise you to have it done by your local authorized Karma dealer.

### 11.2.2 Backrest (seat-to-back) angle

To change the backrest angle, we have to change the position of knobs and nuts connecting the backrest brackets. Please take the following steps:

Step 1: First, use the #13 Open Wrench to remove the nut and knobs on each side of the backrest.



Step 2: Hold the backrest and move it forward or backward to the desired position.



Step 3: Mount the knobs and nuts connecting the backrest brackets and tighten them up.

### 11.2.3 Armrest width:

For Sling Seat, the distance between both armrests can be changed stepless. To change the distance, please take the following steps:

Step 1: Use 5mm Allen key to unscrew the screws securing the armrests.

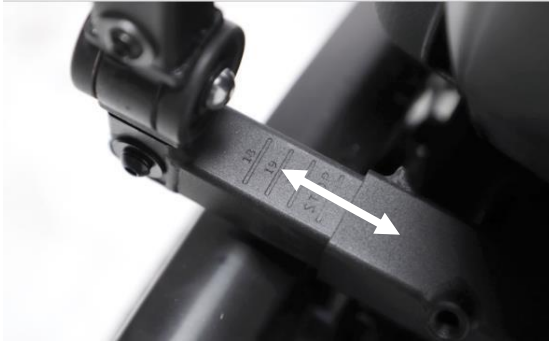

Step 2: Pull the armrest tube out. You will see the scale and a stop indicator. Do not pull the armrest beyond the stop point.

Step 3: Move it to the desired position then tighten the screws.

#### 11.2.4 Armrest height

The armrest height can be adjusted up and down independently. To set the right armrest height, please take the following steps:

Step 1: Use 5mm Allen Key to loosen the height adjustment bolts under the armrest pad.

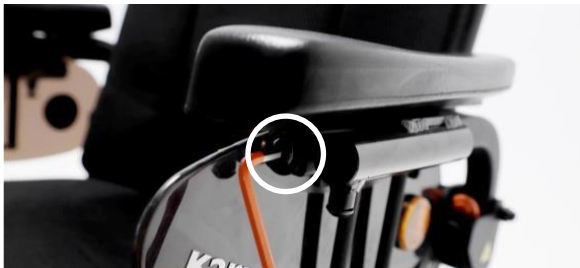

Step 2: Adjust the armrest to the proper height and re-tighten the bolts. Now the armrests are set in to a different height position.





### 11.2.5 Armrest depth

The armrest can be adjusted in depth. To set the right armrest depth, please take the following steps:

Step 1: Use 3mm Allen key to remove two screws shown below.

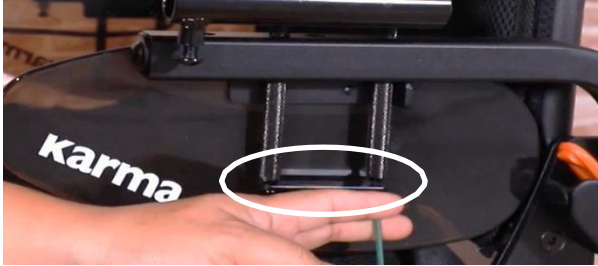

Step 2: Use 5mm Allen key to loosen the height adjustment bolt shown above.



Step 3: Take off the armrest assembly and move it one step forward or backward.



Step 4: Re-tighten the bolts and screws. Now the armrests are set in to a different depth position.

**⚠ CAUTION**

After adjusting the armrest, make sure that user can still access to the joystick. If the user need more adjustment regarding the relative position of the hand and joystick, please refer to the control setting chapter.

### 11.2.6 Footrest longitudinal position

The footrest longitudinal position is adjustable. Both left and right position is separately adjustable. To set the right position, please take the following steps:

Step 1: Use 5mm Allen Key to remove the screws under the seat.



Step 2: Pull out or push in the footrest hanger and find the mounting hole that best fits the user.



Step 3: Re-tighten the screws. Now the footrests are set in to a different position.

**⚠ CAUTION**

When adjusting the footrest longitudinal position, be careful if the footplate interferes with the front caster.

### 11.2.7 Footrest length

The footrest length is adjustable. Both left and right length is separately adjustable. The footrest length should be adjusted according to the user's calf length:

Step 1: Use 10mm Open Wrench and 5mm Allen Key to loosen the bolt and nut at the side of the footplate.



Step 2: Adjust the footplate height and re-tighten the bolt and nut. Now the footplates are set in to a different position.

#### CAUTION

By loosening the bolt on the footplate, the footplate might suddenly start to slide down. If the user has his or her foot on the footplate, this sudden movement might cause a shock reaction.

It is best to hold the footplate with one hand and loosen the bolt with the other hand.

#### NOTE

Make sure the footrest is in the right position. The surface pressure on the upper leg should be equally divided over the total length. Improper length adjustment might lead to pressure points on the upper legs.

#### CAUTION

When adjusting the footrest length, the distance between the footplates to the floor must be at least 50 mm.

### 11.2.8 Headrest setting

The headrest is adjustable in height, depth and angle to the requirements of the user. Please take the following steps:

Step 1: Use 3mm Allen key to adjust the horizontal position from the bracket connecting the headrest to the frame.



Step 2: Use 4mm Allen key to adjust the height from the headrest frame.



Step 3: Use 5mm Allen key to adjust the angle of the headrest.



### 11.3 Positioning belt

The optionally positioning belt can be adjusted in length. To change the setting simply operate from the tri-slide rim.

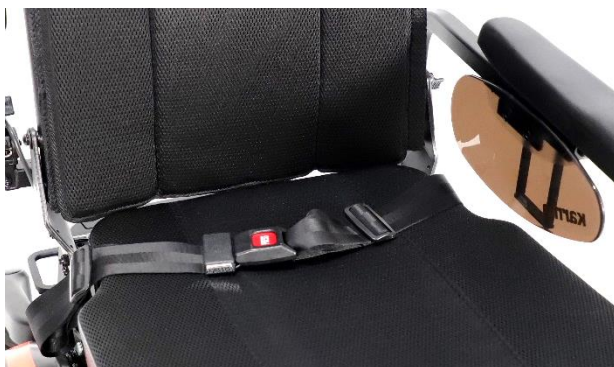

#### **i** NOTE

The positioning belt is not to be used as a safety belt. If the wheelchair is transported in an occupied position, the user needs to wear a safety belt which is mounted in the vehicle he or she is transported in.

## 11.4 Control settings

The side swing-away control joystick module is adjustable in depth and height. To adjust the swing-away part, please take the following steps:

### 11.4.1 Depth adjustment side control

To set the depth adjustment of the side control, follow the next steps:



Step 1: Use 5mm Allen key to loosen up this bolt.

Step 2: Move the bracket into the required depth position.

Step 3: After confirming the position, re-tighten the bolt again.

### 11.4.2 Height adjustment side control

To set the height adjustment of the side control, follow the next steps:



Step 1: Use 3mm Allen key and 8mm Open Wrench to loosen up this bolts and nuts.

Step 2: Move the control into the required height position.

Step 3: After confirming the position, re-tighten the bolts and nuts again.

## 12 Joystick

All functions of the wheelchair can be controlled with this joystick module. This joystick module can be mounted on the left or right armrest. Joystick module contains a few major components which will be explained separately.



### VR2 USER CONTROLS

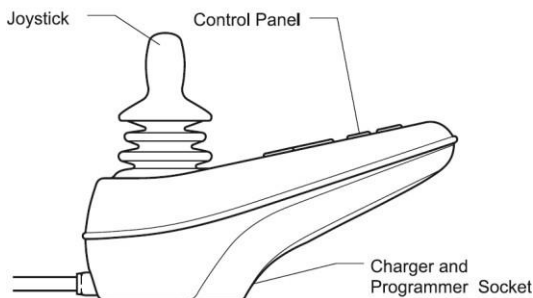

### 12.1 Charging socket

The charging socket is used to charge the batteries. Whilst charging the batteries, the driving of the wheelchair is automatically blocked.

### 12.2 Joystick

The primary function of the joystick is to control the speed and direction of the wheelchair. The further you push the joystick from the center position the faster the wheelchair will move. When you release the joystick the brakes are automatically applied. If the wheelchair is fitted with powered seat functions, the joystick can also be used to move the specific powered seat function.

The joystick is used to drive the wheelchair. Just push the joystick into the direction you want to drive, and the wheelchair will start to move in that direction. (Also refer to the driving technique chapter)

#### CAUTION

We strongly recommend practicing the function of the joystick before starting to drive with the wheelchair.

Several different shapes of joystick knobs are available as options to optimize the control of the joystick.

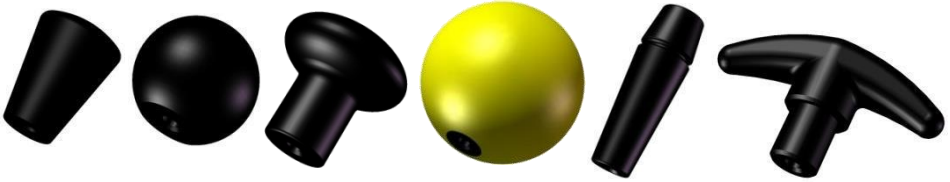

### 12.3 Control panel

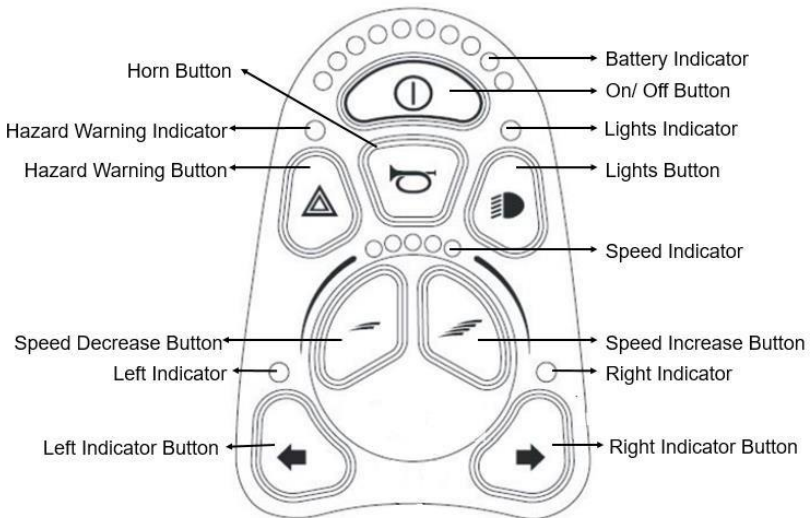

*Control Panel without Power Seat Function*



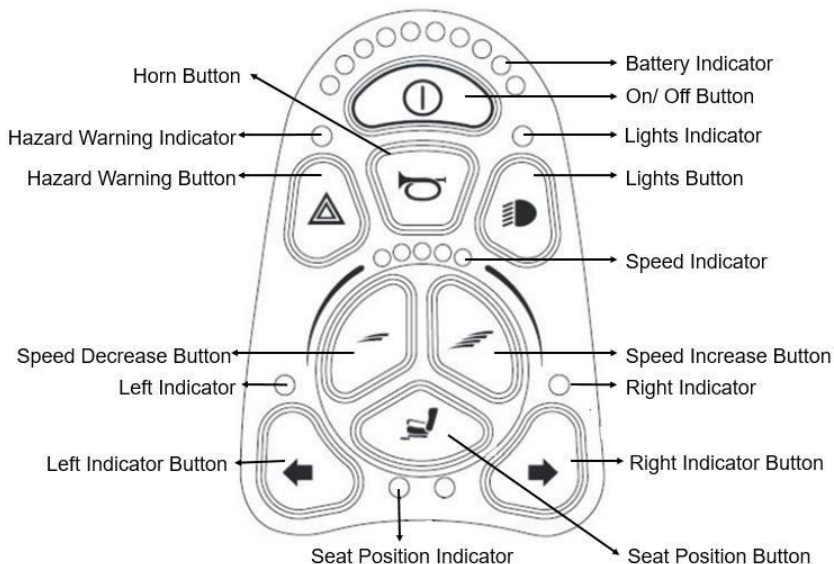

*Control Panel with Tilt*

### 12.3.1 Battery indicator

Battery indicator displays the charge available in the battery and can be used to alert the user to the status of the battery. If all lights are on, the batteries are fully charged. If the capacity is lowered one by one, a light will erase. The bar is divided into three color zones: Green, orange and red. If only the red is left, it means the batteries will be almost empty and need to be charged.

### 12.3.2 On/Off button

The On/Off button applies power to the control system electronics, which in turn supply power to the wheelchair's motors. Do not use the On/Off button to stop the wheelchair unless there is an emergency. (If you do, you may shorten the life of the wheelchair drive components). When turning on, be sure not to touch the joystick. Your battery & diagnostics indicator should light up.

#### CAUTION

Always make sure the wheelchair is switched off before entering or leaving the wheelchair. If the wheelchair is switched on during transferring, there is a danger that the joystick will be touched and the wheelchair will move.

### **12.3.3 Horn button**

The horn will sound while this button is pressed.

### **12.3.4 Speed Indicator**

The speed indicator suggests how fast your wheelchair will be going when you move the joystick. The maximum speed is divided into 5 increment. The more lights that are on indicates the faster that you are driving.

### **12.3.5 Speed decrease/ increase button**

The speed increase button increases the speed setting. (it does not increase the maximum speed!). The speed decrease button decreases the speed setting. The user can adjust the wheelchair's top speed to suit their preferences and environment.

### **12.3.6 Seat position indicator**

This indicator will be lit-on once the Seat Position button is pressed. When the indicator LED is on, it means the control unit is in the Position Mode, as oppose to Drive Mode. Which means, when you push or pull your joystick now, the control unit will activate the tilting function of your wheelchair.

### **12.3.7 Seat position button**

This button shifts your joystick function from Drive Mode to Position Mode (tilting the seat up and back).

To tilt the wheelchair, press this button and pull the joystick towards the user until your preferred position. The maximum tilting angle is 25°. Moving the joystick away from the user will tilt the seat towards the upright position.

### **12.3.8 Hazard warning button**

This button activates and de-activates the wheelchair's hazard lights. Press the button to turn the hazards on and press the button again to turn them off. When activated the hazard LED and the indicator LEDs will flash in sync with the wheelchair's indicators.

### 12.3.9 Lights button

This button activates and de-activates the wheelchair's lights. Press the button to turn the lights on and press the button again to turn them off. When activated the lights, LED will illuminate.

### 12.3.10 Left/ Right Indicator button

This button activates and de-activates the wheelchair's left/ right indicator. Press the button to turn the indicator on and Press the button again to turn it off. When activated the left indicator LED will flash in sync with the wheelchair's indicator(s).

### 12.3.11 Wheelchair lock

The VR2 control system can be locked to prevent unauthorized use. The locking method is via a sequence of key presses and joystick movements, as detailed below.

**To lock** the wheelchair:

Step1. While the control system is switched on, press and hold the on/off button for more than 3 seconds. After one second the control system will beep. Release the on/off button.



Step2. Push the joystick forwards until the control system beeps.

Step3. Pull the joystick in reverse until the control system beeps.

Step4. Release the joystick, there will be a long beep. The wheelchair is now locked.

Use the on/off button to switch the control system on. The maximum speed / profile indicator will be rippling up and down.

**To unlock** the wheelchair:

Step1. Push the joystick forwards until the control system beeps.

Step2. Pull the joystick in reverse until the control system beeps.

Step3. Release the joystick, there will be a long beep.

Step4. The wheelchair is now unlocked.

### **12.3.12 Joystick deflected error**

If the wheelchair is started up and the joystick is not in its zero position, you will see 7 lights twinkling on the battery indicator session. Keep the joystick at its neutral (central) position and restart the on/off button. The system will start up normally and the error disappears.



## 13 Electric system

### 13.1 Batteries

The wheelchair has two serial-connected 12-volt maintenance free batteries for the power supply. The capacity of the batteries is 50Ah. The compartment can hold maintenance free batteries up to 80Ah.

The batteries are fitted in the front and rear of the chassis to arrange a low center point of gravity. Both batteries are easily accessible for maintenance or replacement.

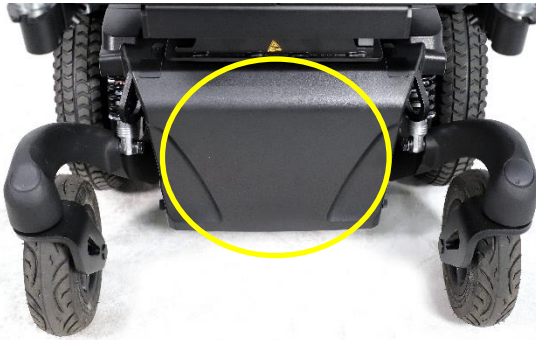

*Position of the front battery box*



*Position of the rear battery box*

#### CAUTION

Be careful when using metal objects close to the batteries. A short circuit might easily create strong sparks and can cause a fire. Should you need to work on the batteries, use isolated tools and wear protective gear on hands and eyes.

**⚠ CAUTION**

Batteries are chemical components and shall be treated as such. In case of removal, one shall treat the batteries as chemical waste. The batteries need to be disposed according to the local regulations for chemical waste.

### 13.2 Main Fuse

The wheelchair has one circuit breaker to protect the batteries against overload and short circuit. This circuit breaker is easy to reach and placed on the right front cover of the wheelchair. The electronics itself is completely protected against short circuit and overload.



*Position of the circuit breaker*

**⚠ CAUTION**

If the circuit breaker is blown, please contact your local authorized supplier. He should check the wheelchair first before replacing the circuit breaker. The circuit breaker only blows if a serious problem occurs.

**⚠ CAUTION**

Only use original circuit breaker as replacement. Using other circuit breaker might damage the electronic system or even cause fire.

## 14 Using the wheelchair

### 14.1 General warnings and advices

Please read this section of the manual very carefully as it contains issues related to safety and possible hazards.

#### WARNING

- When the user is driving the wheelchair for the first time, the supplier has to make sure that the maximum driving speed and curving speed are set in a slow mode. After learning to drive the wheelchair safely, the set speeds can be increased.
- Special care should be taken in driving on unequal surfaces such as slopes, unequal pavements and during descending from footpaths.
- It is not allowed to carry passengers other than the user on the wheelchair.
- On slippery surfaces, like ice and snow, the driving speed must be reduced accordingly.
- Do not drive through water puddles, you cannot see how deep they are. This might lead to dangerous situations. Water can damage the wheelchair.
- Only charge the wheelchair in well ventilated areas.
- Note that no other persons or animals are in the direct contact zone of the wheelchair when using it. This is for both driving and using the high low. Because the wheelchair is a very powerful machine with a relative high weight this might lead to severe injuries.
- When driving the wheelchair in the dark, be sure that you have the lights switched on.
- Always drive slowly in the near surrounding of other people or animals.
- Although the wheelchair is intensively tested, it cannot be excluded completely that the wheelchair influences the performance of electromagnetic fields (e.g. Alarm systems of shops, automatic doors etc.).
- The driving characteristics of the wheelchair can be influenced by strong electromagnetic fields (e.g. Those emitted by portable telephones, electricity generators or high-power sources. Try to avoid the near presence of any radiation source such as radios, cell phones etc. If your wheelchair reacts to a source of radiation with unexpected behavior, try to drive slowly to a safe place, turn off your wheelchair and try to extinguish the radiation source.

## 14.2 Use in combination with other products

Different- or customized seat:

### WARNING

- The combination of seat and user does not exceed the maximum allowed weight on the wheelchair carrier and tilt mechanism.
- The seat is fixed properly to the seat post.
- The center of gravity of the combination of user and seat is on the same spot as when the standard seat would be used.
- The position of the tray table and/or the control unit is comfortable and easy to use for the user.
- The used materials are in compliance with the accepted standards mentioned in EN 12184 regarding flame resistance and biocompatibility.
- The seat or any other mounted parts do not touch the wheelchair carrier when using the high low function. Because the dimensions will vary from the standard seat. This has to be checked by watching these parts when activating the high low.
- The seat or any other mounted parts do not touch the wheelchair carrier when using the tilt function. Because the dimensions will vary from the standard seat. This has to be checked by watching these parts when tilting the chair.

### WARNING

Changes which are made by third parties are not covered by the warranty and responsibility of Karma Medical.

## 14.3 Hot and cold surfaces

### WARNING

Some parts of the wheelchair can reach high temperatures when exposed to direct sun. Please be careful with touching especially the plastic parts under these circumstances in order to prevent skin burning.

### WARNING

The wheelchair can reach low temperatures when exposed to cold weather (below zero degrees Celsius). Please take caution in touching especially the metal parts with wet body parts under these circumstances as they easily can freeze and get stuck to these surfaces.



## 14.4 Danger of pinching

### User

Special care has been taken to make sure that the chance that the user pinches him or herself while seated in the wheelchair is minimal. However, there are few situations that might lead to injury. Special caution has to be taken under the following circumstances;

- When the tray table is closed, pinching of fingers or other body parts is possible between the locking parts.
- When the revolving control unit is used in the tray table, pinching of fingers or other body parts is possible when the control unit is being turned upside down.
- When adjusting the seat while the user is sitting in the chair, please note that no body parts are in the direct zone of the moving parts.

### WARNING

When moving the seat down, the tilt frame comes very close to the top chassis cover. This creates a pinching danger, when at this time, hands are on the top cover at the rear end of the chassis. For this reason a warning decal is placed on the top cover on the rear of the chassis. We advise you to always keep your hands or the hands from other persons away from the rear end of the top chassis cover.

### WARNING

All areas where there might be a risk of pinching are indicated by these warning decal:



## 14.5 Surroundings

Special care has been taken to make sure that the change that the surroundings pinches him or herself is minimal. However, there are few situations that might lead to injury. Special caution has to be taken under the following circumstances;

- When driving the wheelchair, make sure that no persons or animals are in the near surrounding, because running over e.g. feet will lead to serious injury as a result of the high weight of the electrical wheelchair.
- When using the seat lift and/or the electrical tilt adjustment, make sure that no persons or animals are in the near surrounding, because it is possible to get pinched by the moving mechanism, although the moving parts are designed to be as safe as possible.

## 14.6 Precautions to prevent dangerous situations

In order to prevent dangerous situations please take note of the following precautions:

- Only charge the battery in well ventilated areas.
- Only drive at slow speed in the direct surrounding of other people or animals.
- Always turn on the head and rear lights when using the chair under circumstances with limited sight like darkness or fog.
- Please do not allow any persons to stand or sit on the wheelchair except for the user.
- Make sure that the remaining battery power is sufficient for the distance that is to be bridged.
- Do not replace a damaged fuse before it is known why the fuse is blown and the cause is taken away.
- Have the wheelchair checked by your supplier after any collision or when the wheelchair is otherwise (visual) damaged.
- Check the tire pressure and refill the tires, if necessary, every four weeks. Check the tires at the same time for wear and damage. Replace if necessary.

- In order to ensure that your wheelchair is in good condition, please contact Karma authorized dealers regularly and make further wheelchair inspection and maintenance records. We recommend that you inspect and maintain your wheelchair **every six months**.
- Do not change the programmed driving characteristics of your control unit, as it is specific for the situation of the user. If any adjustment is required because of a change of circumstances, please contact your supplier.

**⚠ WARNING**

Always make sure that, when positioned on slopes, the brakes are attached (no Freewheel). If the wheelchair is in freewheel mode, there is a risk that the wheelchair might start to move in an uncontrolled way. This might lead to personal or material damage.

### **14.7 Use on slopes: driving on downhill slopes**

Driving on downhill slopes must always be done at a low speed and with great care. Avoid sudden braking, abrupt avoidance maneuvers and never maintain a speed higher than that at which you can maneuver the wheelchair in a safe and secure manner. Always be aware of the fact that the control of the wheelchair driving downhill is different than on level surfaces.



*Max. acceptable downhill slope*

 **NOTE**

When driving on downhill slopes with an uneven or slippery surface (for example grass, gravel, sand, ice or snow) you should drive with extra care and attention.

 **NOTE**

When driving on downhill you can use the tilt (if build in) to create a more stable seating position for yourself.

 **WARNING**

Never drive downhill on slopes bigger than 6°. This might result into uncontrollable behavior of the wheelchair. This can lead to material or personal damage. (Dynamic stability according to ISO 7176-2= 6°).

 **WARNING**

The position of the seat in height and angle or the position of the backrest has great influence on the stability of the wheelchair if driving on slopes. Make sure the seat is in the optimal driving position to avoid tipping over.

## 14.8 Use on slopes: driving on uphill slopes

Driving on uphill slopes must always be performed with great care and attention. Avoid sudden avoidance maneuvers and never drive at a speed higher than needed to maneuver the wheelchair in a safe and secure way. Avoid holes and bumps as much as possible. Drive slowly and controlled.



*Max. acceptable uphill slope*

**i NOTE**

When driving on uphill slopes with an uneven or slippery surface (for example grass, gravel, sand, ice or snow) you should drive with extra care and attention.

**⚠ WARNING**

Never drive uphill on slopes bigger than 6°. This might result into uncontrollable behavior of the wheelchair. This can lead to material or personal damage. (Dynamic stability according to ISO 7176-2= 6°)

**⚠ WARNING**

The position of the seat in height and angle or the position of the backrest has great influence on the stability of the wheelchair if driving on slopes. Make sure the seat is in the optimal driving position to avoid tipping over.

## 14.9 Driving on sideways slopes

Driving on a sideways slope must always be performed with great care. Avoid sudden avoidance maneuvers and never drive at a speed higher than needed to maneuver the wheelchair in a safe and secure way. Avoid holes and bumps as much as possible. Drive slowly and controlled.



*Driving on sideways slopes*

### NOTE

When driving on sideways slopes with an uneven or slippery surface (for example grass, gravel, sand, ice or snow) you should drive with extra care and attention.

### WARNING

Never drive sideways slopes bigger than 6°. This might result into uncontrollable behavior of the wheelchair. This can lead to material or personal damage. (Dynamic stability according to ISO 7176-2= 6°)

### WARNING

The position of the seat in height or the position of the backrest has great influence on the stability of the wheelchair if driving on slopes. Make sure the seat is in the optimal driving position to avoid tipping over.

## 14.10 Obstacle climbing

Do not drive the wheelchair over obstacles of a height bigger than 75mm. Driving over tall edges increases the risk of tipping over as well as the risk of damage to the wheelchair. Always be aware when climbing obstacles of the stability of your wheelchair.



Driving down of a higher surface (like pavement), always be aware of the sudden forward movement of your wheelchair when driving down of it. If your wheelchair has powered seat tilt, you can use the seat tilt for more stability whilst driving of the pavement.

### NOTE

When driving over obstacles with uneven or slippery surface (for example grass, gravel, sand, ice or snow) you should drive with extra care and attention.

### WARNING

Never drive on obstacles higher than 75mm. Always drive with maximum attention and great care.

### 14.11 Use in presence of electromagnetic fields, e.g. from cell phones.

Use your cell phone only when the wheelchair is switched off. Although the wheelchair is tested and approved for electromagnetic interference, there is a very small change that strong electromagnetic fields from cell phones or some other electrical products lead to unexpected and unpredictable electrical reactions from the wheelchair.

Try to avoid the near presence of any radiation source such as radios, cell phones etc. If your wheelchair reacts to a source of radiation with unexpected behavior, try to drive slowly to a safe place, turn off your wheelchair and try to extinguish the radiation source.

When it is unavoidable to use the wheelchair under these circumstances, be prepared for any unexpected and unpredictable electrical reactions from the wheelchair.

 **WARNING**

If you enter an area where there might a risk of strong electromagnetic interference, always reduce your driving speed and drive carefully.

 **WARNING**

Avoid area's where strong military transmitters are used. They might interfere with your wheelchairs electronics.

 **WARNING**

Avoid areas close to high voltage power lines. They might interfere with your wheelchairs electronics.

 **WARNING**

Avoid areas close to high frequency energy equipment, like high frequency welding machines. They might interfere with your wheelchairs electronics.



## 15 Driving the wheelchair

The wheelchair is designed for indoor and outdoor use. When driving indoors, you must be careful when driving in, for example, narrow passageways, when passing through doors and entryways as well as when using elevators, ramps, etc. Also be aware of the risk of things getting caught in the machinery when you use the electrical seat lift and seat tilt, in particular when the wheelchair has been run in under a table, workbench or something like that.

### WARNING

Always make sure the wheelchair is switched off before entering or leaving the wheelchair. If the wheelchair is switched on during transferring, there is a danger the joystick will be touched and the wheelchair will move.

Outdoors, you must remember to drive very slowly on steep downhill slopes and to be very careful when driving on uneven surfaces, on uphill slopes, with sideways slopes and when negotiating obstacles. Always maintain a safe distance from the edge when driving close to drop-offs and pavements.

### NOTE

We recommend that you should make repeated test drives in areas in which you know you feel secure so that you are quite familiar with how the wheelchair and its accessories behave in different situations before you begin using the wheelchair on normal roads and other public areas.

### 15.1 Driving in general

Make sure that the control system is mounted right, and that the joystick position is correct. The hand or limb you use to operate the joystick should be supported, for example by the wheelchair armrest. Do not use the joystick as the sole support for your hand or limb, the wheelchair movements and bumps could upset your control, which might result in uncontrolled driving.

1. Switch on the power by pressing the on/off button on the control panel.
2. Select the right profile (start with the indoor profile) Preferable to begin with a low driving speed.

**WARNING**

Always make sure the wheelchair is switched off before entering or leaving the wheelchair. If the wheelchair is switched on during transferring, there is a danger the joystick will be touched, and the wheelchair will move.

3. Set an appropriate maximum speed by pressing the decrease or increase button until the desired indicator lamp lights up for your type of driving. It is
4. Carefully move the joystick forward to drive forward, and backward to drive backward.
5. The speed of the wheelchair is adjusted continuously by the joystick being moved different distances forward and backward respectively. The wheelchair's electronics make creep driving possible over edges (max. 50mm.). You can drive up to the edge, and then carefully drive over it.

**WARNING**

Do not perform the first test drive on your own. The test drive is of course just a check of how you and the wheelchair function together, and you may need some assistance. Before driving, check that the wheel freewheel is set in the drive position.

### 15.2 Driving technique

The electronic control system of the wheelchair “reads” your joystick movements and transforms these “commands” into movements of the wheelchair. You will need very little concentration to control the wheelchair, which is especially useful if you are inexperienced. One popular technique is to simply point the joystick in the direction you want to go. The wheelchair will move in the direction you push the joystick.

Always think about driving as flexibly and fluently as possible and avoid heavy braking and avoidance maneuvers. The smoother you move the joystick, the smoother the wheelchair will drive.

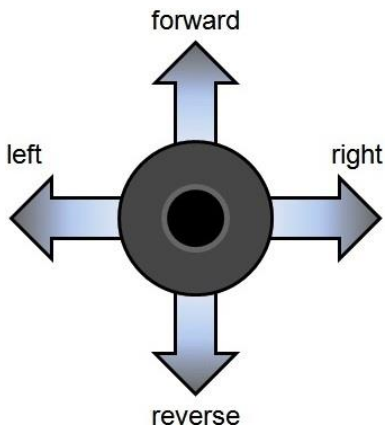

## 15.3 Stopping the wheelchair

If you would like to stop simply move the joystick slowly towards the center and release the joystick. The wheelchair will come to a gentle stop. If you want to stop more quickly, simply let go of the joystick. It will put itself back into neutral position, which makes the wheelchair stop. Is there an emergency situation and you need to make an emergency stop, pull the joystick backwards. This will slow down and stop the wheelchair very fast.

### WARNING

Be careful driving backwards. You cannot really oversee where you are driving. It is better, when the space is available, to turn around and drive forward. By driving backwards not seeing where you are heading you might bump into something or someone. This can lead to personal or material damage.

### WARNING

Be careful using the emergency brake. Especially when driving on slopes. Extreme braking might create the risk of tipping over when you are on a slope. Also, be aware that during braking you tend to lose balance yourself. If not strapped into a seat belt you might run the risk of falling out of your wheelchair whilst braking very hard.

## 16 Using the powered seat functions

### 16.1 Seat tilt/ Backrest recline

To tilt the chair or recline the backrest, first turn on controller from On/Off button. Then, press the Seat Position button on your control panel. You will see the Seat Position indicator light up.



*Pull the joystick towards the user*

For seat tilt, now pull the joystick towards the user and the seat tilt will start to tilt backwards. As long as you pull the joystick backwards, the seat tilt will tilt backwards. Release the joystick and the seat tilt movement will stop. Push the joystick forward and the seat will tilt into forward position.

For backrest recline, now pull the joystick towards the user and the backrest recline will start to recline backwards. As long as you pull the joystick backwards, the backrest recline will recline backwards. Release the joystick and the backrest recline movement will stop. Push the joystick forward and the backrest will recline into forward position.



#### **NOTE**

The acceleration and speed of each seat function can be programmed by your local authorized supplier. Should you request a different setting, please contact your local authorized supplier.

## **17 Handling the mechanical brakes**

The drive motors of the wheelchair have electromechanical brakes. The brake can be released to set the wheelchair into freewheel mode. In freewheel mode the wheelchair can be pushed. This might be necessary to move the wheelchair in certain cases.

### **17.1 Release the mechanical brakes**

To release the mechanical brakes, take the following steps:

Look for the red lever on each side of the driving motor.

Around the lever is an instruction sticker which shows the direction to open or lock the mechanical brake. Move the lever into the "open" position on each motor. Now the wheelchair is in freewheel mode and can be pushed.

To lock the brakes, move the lever into the "lock" position on both motors.



**i NOTE**

If you want to put the wheelchair into freewheel mode, be sure to switch the electronics first. Leaving the electronics switched on will result a large resistance whilst pushing in freewheel mode.

**⚠ WARNING**

If the parking brake is released (free-wheel mode), the wheelchair cannot be driven by the electronics. Therefore, the release of the brakes should only be done in emergency cases and or for servicing. If the user is on board, the parking brakes should always be attached.

**⚠ WARNING**

Always make sure that, when positioned on slopes, the brakes are attached (no Freewheel). If the wheelchair is in freewheel mode, there is a risk that the wheelchair might start to move in an uncontrolled way. This might lead to personal or material damage.

## 18 Charging the maintenance free batteries

The amount of charge in your maintenance free batteries is depending on a number of factors, including the way you use your wheelchair, the temperature of the maintenance free batteries, their age and the type of maintenance free batteries used. These factors will affect the distance you can travel in your wheelchair. All wheelchair maintenance free batteries will gradually lose their capacity when they get older.

The most important factor that is reducing the life span of your batteries is the amount of charge you take from the batteries before you recharge them. The maintenance free battery life is also reduced by the number of times you charge and discharge the batteries. Normally the amount of cycles is between 300 and 700 times. To make your maintenance free batteries last longer, do not allow them to become completely discharged.

Always recharge your maintenance free batteries promptly after they are discharged. If your battery gauge reading seems to fall more quickly than usual, your batteries may be worn out. If your wheelchair shows these indications, please contact your local authorized supplier to have the maintenance free batteries checked.

### 18.1 Battery level

The power level of the batteries is displayed on the LCD screen of the joystick module.

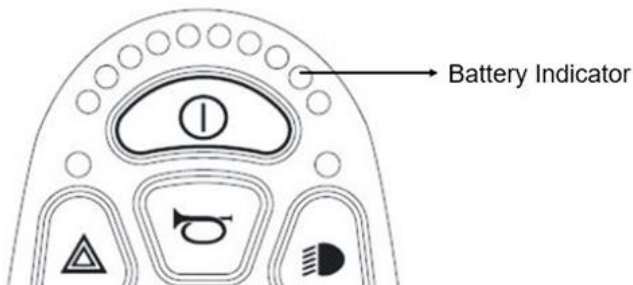

If the maintenance free batteries are fully charged, all ten LED's on the top bar light up. The more energy is used the more LED extinguish, starting on the right side.

If only the red LED are still on, it indicates that recharging of the maintenance free batteries is required.

If only two red LED's are flashing, it indicates that the maintenance free batteries are empty and should be charged immediately.

**i NOTE**

If the battery indicator shows only two segments in flashing, you should charge the batteries as soon as possible. This flashing is a warning signal. You are still able to drive the wheelchair but only for a short distance. If the batteries reach a level where they cannot supply enough energy to control the wheelchair in a safe way. The wheelchair will stop and give an error warning saying "low battery voltage"

**i NOTE**

If the batteries are drained completely, it is important that you charge them up again as soon as possible since a complete loss of charge reduces the lifespan of the batteries.

**i NOTE**

Information about the charger which is supplied with the wheelchair can be found in the user manual of the charger itself. You can find the charger user manual in the tool bag which comes with the wheelchair.

**i NOTE**

Some local dealers supply the wheelchair with their own brand of batteries and battery charger. For information about these batteries and charger, you should ask your local authorized supplier.

## 18.2 Charging socket

The charger socket can be found on the front side of the joystick module. If the wheelchair has an integrated desktop control, the charger socket will be on the side of the joystick module.



*Charger socket position*

The wheelchair can be delivered with a battery charger. The charger has a capacity to charge up to 5 amperes. This charger will fully charge the batteries within 10 hours.

**i NOTE**

For more detailed information about the charger and its functions, we refer to the manual which comes with the charger. Charger can be supplied by your local dealer.

**i NOTE**

In some occasions putting in the charger socket yourself can be very difficult. Optionally, the wheelchair can be supplied with charger socket which can be placed on the spot you can reach yourself. For more information, please contact your local authorized supplier.

**⚠ WARNING**

Be sure that the charger plug is pushed fully in position. You will not be able to drive the wheelchair when the charger is connected. If the wheelchair does drive with the charger plugged in, contact your local authorized supplier.

**i NOTE**

In some occasions it might be the case that your local supplier will deliver the wheelchair with a different brand charger. In that case your local supplier will inform you about the functionality of that charger and will also make sure the charger comes with a user manual.



### 18.3 Disposal of broken or worn out batteries

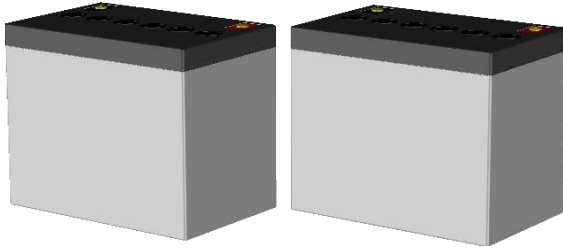

Batteries don't last forever. Therefore, batteries need to be changed after a certain period. The safest way is to have this done by authorized personnel of your local supplier. Batteries are chemical waste and need to be treated as such, using protective clothing, gloves and glasses.

 **WARNING**

Replacing damaged or old batteries needs to be done by authorized personnel wearing protective clothing, gloves and safety glasses.

 **WARNING**

Old or damaged batteries are classified as chemical waste and need to be disposed according to the local regulations for chemical waste. Please contact your local supplier for further details.

## 19 Transport of the wheelchair

### 19.1 4-point Tie-down belts

The Morgan M Sling (MGNM-SLN) complies with the requirements specified in ISO 7176-19:2022. It has been designed and tested according to the ISO 7176-19:2022, for transportation in an occupied position, forward facing in a vehicle.



The wheelchair is designed to use a 4-point heavy duty webbing restraint. For this matter the wheelchair has two brackets on the front end and two brackets on each rear side of the chassis. The brackets are indicated with a sticker. These anchoring point shall be used to connect the tie-down belt to.

For the tie down belt we advise to use a Dahl heavy duty tie-down belt, model 501780 or 501781. The angle of the straps should be around 45° to the horizontal plane. This is in order to have maximum effect in vertical and horizontal direction.



The straps have to be connected to the vehicle at suitable anchor points. Make sure that the tire pressure is at the recommended level so the straps can have maximum effect. Make sure the straps are tightened to maintain optimal security.

 **WARNING**

Standard ISO 10542-1 approved 4 point WTORS (wheelchair Tie down and Occupant Restraint Systems), are only tested to 85kg. For wheelchairs heavier than 85kg it is recommended to use an ISO 10542-1 WTORS (heavy duty system), which is rated for the total weight of the wheelchair including any options. If using a HeavyDuty System, use 4 straps to secure the wheelchair, 2 straps at the front and 2 straps at the rear. Never use equipment not labelled with ISO 10542.

 **WARNING**

Poor fixations of the wheelchair in a vehicle might cause damage to the vehicle itself, the wheelchair or the passengers inside the vehicle while driving. Not using a car safety belt while sitting in a wheelchair might lead to serious injuries in case of an accident.

 **NOTE**

The access to, and maneuverability in, motor vehicles can be significantly affected by wheelchair size and turning radius. Smaller wheelchairs and/or wheelchairs with a shorter turning radius will generally provide greater ease of vehicle access and maneuverability to a forward-facing position in the vehicle. Also, the internal size of the vehicle will have a great influence of the maneuverability into and out of the vehicle. Make sure there are loose object inside the vehicle which might make entering en positioning inside the vehicle more complicated.

 **NOTE**

Although the wheelchair is designed and tested according to the ISO 7176-19:2022 requirements, we also advice: wheelchair users should transfer to the vehicle seat and use the vehicle-manufacturer-installed restraint systems whenever it is feasible, and the unoccupied wheelchair should be stored in a cargo area or secured in the vehicle during travel.

**i NOTE**

For more information, tie down kits for vehicles and or further information about tie-down belt and occupant 3-point safety belt, please visit the website of Dahl engineering at [www.dahlengineering.dk](http://www.dahlengineering.dk)

**19.1.1 Safety belt:**

If the user is transported in his wheelchair, it is necessary to use a car safety belt to secure the wheelchair user.

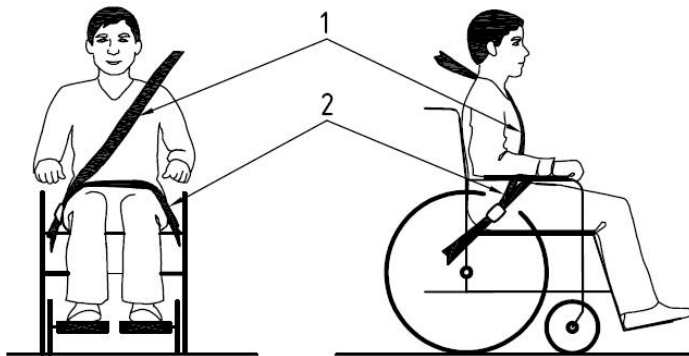

*Positioning of the car safety belts for wheelchair users.*

The wheelchair has been crash tested using tie down belts, and a 3-point occupant safety belt. We advise you to use a Dahl 3-point occupant safety belt model 500984 system or a system that is equally specified. It is very important to use the safety belt in the right angles according to the wheelchair user. The angle for the pelvis part (2) of the safety belt must be in angle of 30- 75 ° with the horizontal plane. (See picture below). Also, the side angle should stay

between the vertical planes to maximum of 15° angle with the vertical plane.  
(See picture below).

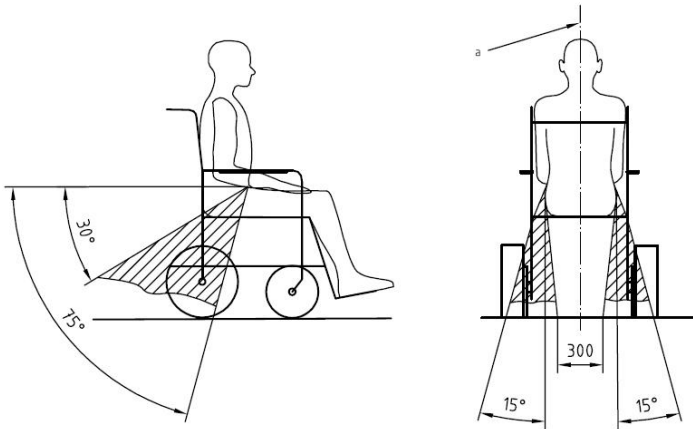

*Optimal angles for a safety belt used by the wheelchair user*

The shoulder part (1) of the safety belt should be positioned according to the figure below.

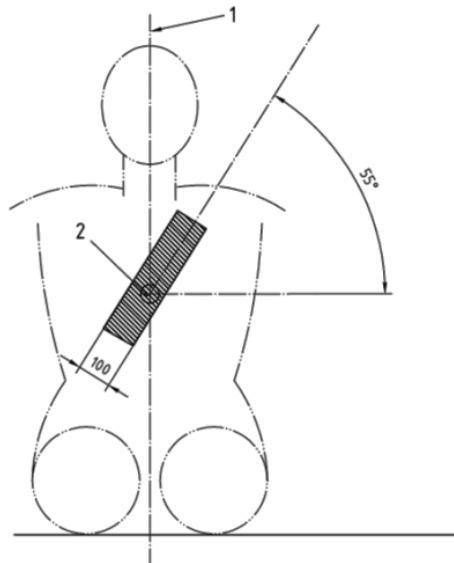

*Shoulder safety belt positioning*



## NOTE

Please obtain the following points for an optimal personal safety of the wheelchair user:

- the pelvic belt should be worn low across the front of the pelvis, so that the angle of the pelvic belt is within the preferred zone of 30° to 75° to the horizontal, as shown in figure above.
- a steeper (greater) angle within the preferred zone is desirable.
- belt restraints should not be held away from the body by wheelchair components or parts, such as the wheelchair armrests or wheels, along with an illustration similar to that of the figure shown above.
- upper torso belts should fit over the shoulder and across the chest, as illustrated in figure of the shoulder safety belt positioning.
- belt restraints should be adjusted as tightly as possible, consistent with user comfort.
- belt webbing should not be twisted when in use.

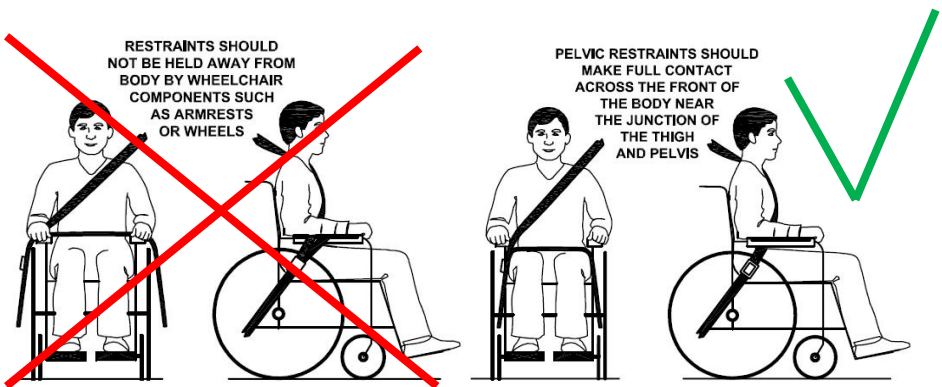

**NOTE**

**Please, make sure the following conditions are fulfilled to obtain a safe transportation:**

- DANGER! Any wheelchair anchored occupant restraint i.e. 3-point belt, harness or postural supports (lap straps, lap belts) should not be used or relied on for occupant restraint in a moving vehicle, regardless if labeled ISO 7176-19, ISO 10542-1, SAE J2249 or any other. Use a vehicle anchored and certified occupant restraint system instead.**
- Whenever possible the occupied wheelchair shall be located in a forward-facing configuration and secured by the tie downs in accordance with the WTORS (wheelchair tie down and occupant-restraint system) manufacturer's instructions.**
- This wheelchair is suitable for use in vehicles and has met the performance requirements for travelling forwards-facing in frontal impact conditions. Its use in other configurations within a vehicle has not been tested.**
- The wheelchair has been dynamically tested in a forward-facing orientation with the ATD (anthropomorphic test device) restrained by both pelvic and upper torso belts.**
- Both pelvic and upper torso belts should be used to reduce the possibility of head and chest impacts with vehicle components.**
- When possible, other auxiliary wheelchair equipment should be either secured to the wheelchair or removed from the wheelchair and secured in the vehicle during transit, so that it does not break free and cause injury to vehicle occupants in the event of a collision.**
- The wheelchair should be inspected by a manufacturer's representative before reuse following involvement in any type of vehicle impact.**

**NOTE**

- Alterations or substitutions should not be made to the wheelchair securement points or to structural and frame parts or components without consulting the manufacturer.**
- Only use "gelled electrolyte" batteries on powered wheelchairs when used in a car.**

**WARNING**

Special care should be taken when applying the occupant restraint to position the seatbelt buckle so that the release button will not be contacted by wheelchair components during a crash.

### 19.1.2 Backrest, legrest and headrest settings during transportation

During transportation in an occupied position, the backrest of the wheelchair needs to be set into an upright position. The legrest should be in a knee angle close to 90 degrees. The headrest needs to be adjusted well so it will catch the head of the wheelchair user during the rebound of an impact, this to reduce the risk of a whiplash.



*Recommended position of the backrest, legrest and headrest*

### 19.2 Transportation on an airplane

When transporting your wheelchair by air, you should primarily pay attention to the following in below:



### 19.2.1. Batteries

*Gel batteries:* In most cases, they do not need to be removed from the wheelchair. The batteries only need to be disconnected from the wheelchair. To do this simply disconnect one of the battery pole connectors.



*Position of the battery pole (behind the black cover)*

*Acid batteries:* Most airlines require that batteries be removed from the wheelchair and transported in special boxes that the airline may provide.

When transported by air, the wheelchair will be put with other goods in a confined space. Therefore, it is important to take preventive action to minimize transport damage to the wheelchair. Cover the control panel with soft, shock-absorbing material (foam plastic or similar) and fold it in towards the back rest. Protect other protruding objects in a similar manner. Tape any loose cables to the seat or covers.

### 19.2.2. The wheelchair's dimensions and weight

How much the wheelchair weighs and how large it is are important, depending on the type of airplane in which the wheelchair is to be transported. The smaller the airplane is, the smaller the wheelchair may be/weigh and vice versa. Always check with the airline what rules apply.

### 19.3 Transportation using Dahl Docking station

Morgan M Sling (MGNM-SLN) has been crash tested using a Dahl docking station tie down system according to 7176-19:2008 and 10542-1:2012 SWM, where the wheelchair is facing forward in driving direction (driving direction like the driver seat).



*Morgan M Sling (MGNM-SLN) crash test using Dahl docking station*

The locking of the wheelchair into the Dahl Docking station makes it much easier to lock down the wheelchair for occupied transportation. It can be used also for wheelchair users who want to drive the car by themselves. The system is self-locking and can be release by pushing a button. The locking device will open up for a certain time to make the un-docking possible.

#### **WARNING**

The Dahl Docking station is only allowed to build in to a vehicle by trained and authorized staff of a registered car adaptation company. For ordering the Dahl Docking and its accessories, please contact Dahl Engineering in Denmark for further details. You can find Dahl at [www.dahlengineering.dk](http://www.dahlengineering.dk)

### 19.3.1 Mounting of the Dahl locking adapter on the wheelchair

The Morgan M Sling (MGNM-SLN) chassis can be equipped with a Dahl lock plate underneath the battery box frame of the chassis.



*Morgan M Sling (MGNM-SLN) chassis with Dahl lock plate mounted.*

For detailed information about the Dahl Docking system, please visit the homepage: [www.dahlengineering.dk](http://www.dahlengineering.dk)

To fit the Dahl lock plate, Dahl has created a special kit for Morgan M Sling (MGNM-SLN) chassis which included the special Dahl nut plates and the spacers for the battery box of Morgan M Sling (MGNM-SLN) to level the battery. This kit is available under Dahl part no: 503339.

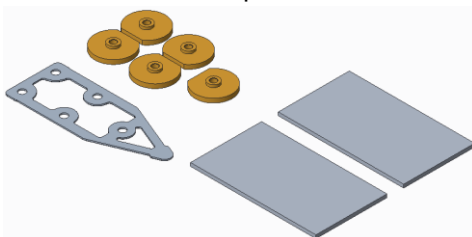

*Morgan M Sling (MGNM-SLN)/Dahl mounting kit nut and spacers*

#### **WARNING**

The Dahl Docking station is only allowed to build in to a vehicle by trained and authorized staff of a registered car adaptation company. For ordering the Dahl Docking System and its accessories, please contact Dahl Engineering in Denmark for further details. You can find Dahl at [www.dahlengineering.dk](http://www.dahlengineering.dk)

The Morgan M Sling (MGNM-SLN) chassis has dedicated holes in the chassis where the Dahl lock plate can be mounted on.



*Dedicated holes for mounting Dahl lock plate*

1. Remove the rear battery from the Morgan M Sling (MGNM-SLN) Chassis and put the special Dahl nut plates in to the dedicated mounting holes from the inside of the battery box.

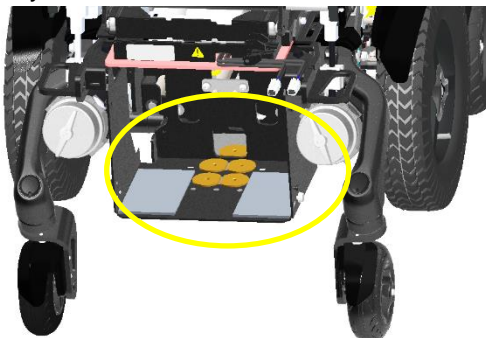

2. Place two plastic spacers (Dahl part no. 501910) in the battery box just like the drawing in the above. The best is to fix them with some double sided tape.

3. Take the 2 mm spacer (Dahl part no. 500671), and install it under the battery box to make it level on the underside of the battery box.

4. Then add the 8 mm spacer (Dahl part no. 500673) under the 2 mm spacer (Dahl part no. 500671). Then there are 10 mm spacers in total. Next, mount the lock plate (Dahl part no. 500561) under the spacers.

5. Note that the following parts are the standard parts that come with the complete docking station: 8 mm spacer (Dahl part no. 500673), the lock plate (Dahl part no. 500561) and the 5 pieces of Dahl high grade steel (14.9) Torx bolts (Dahl part no: 502800)

**i NOTE**

The special Dahl high grade Torx bolts (Dahl part no: 502800) only come in one length which often is too long. They need to be cut into the right length by the authorized engineer to fit the lock plate properly without damaging the batteries.

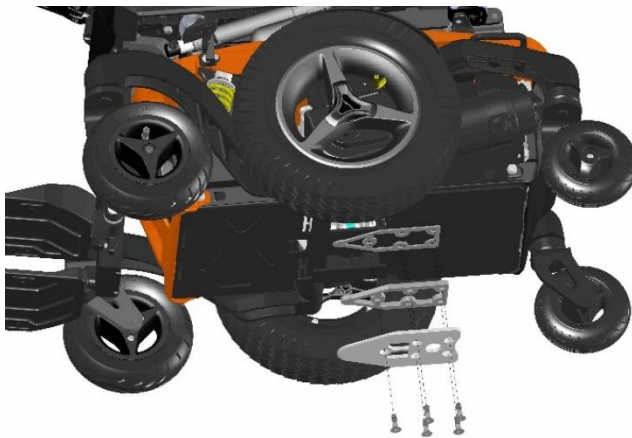

*Mounting the Dahl lock plate on to the Morgan M Sling (MGNM-SLN) chassis*

6. After cutting the bolts to the right length, Loctite 222 needs to be added on to the thread to secure the bolts.
7. The five Torx bolts shall be tightened with a torque wrench to the preset torque of 16-18 Nm.
8. Place the batteries back into the chassis and connect them to the electronics.

Now the Morgan M Sling (MGNM-SLN) chassis is ready to be docked into the Dahl Docking Station. For the Dahl Docking Station, both Dahl Docking Station MK II and DAHL VarioDock™ are compatible with the Morgan M Sling (MGNM-SLN) chassis. If you want to have more flexibility in height adjustment

for securing wheelchairs with different ground clearances, you could choose the latter.

The mounting of the Dahl docking station into your vehicle shall only be executed by an authorized car adaptation company. They will get the right support and information from Dahl Engineering how to mount the docking station in to the designated vehicle.

 **WARNING**

The Dahl Docking Station is only allowed to build in to a vehicle by trained and authorized staff of a registered car adaptation company. For ordering the Dahl Docking System and its accessories, please contact Dahl Engineering in Denmark for further details. You can find Dahl at [www.dahlengineering.dk](http://www.dahlengineering.dk)



Content of **DAHL DOCKING STATION MK II** Art.no. 501750.



Content of DAHL VARIODOCK™ Art. no. 503600.

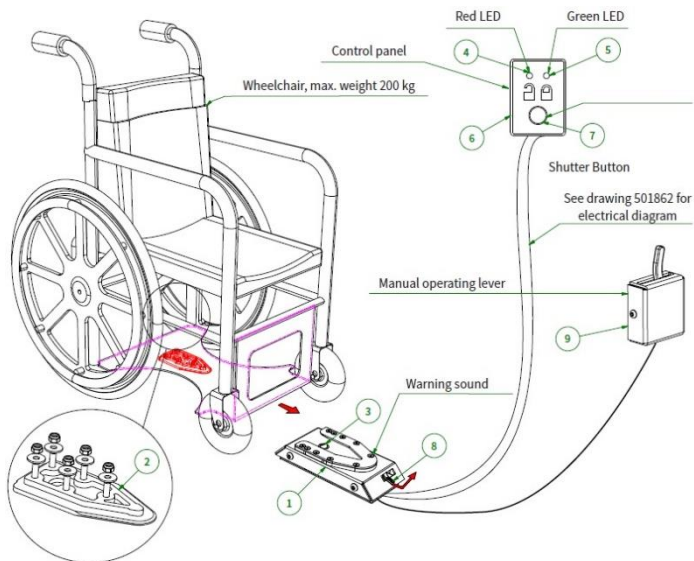

DAHL DOCKING STATION MK II function description

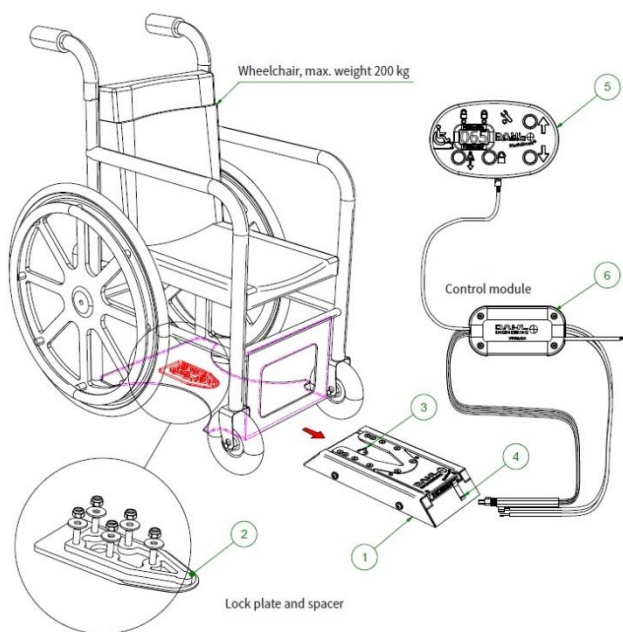

### *DAHL VARIODOCK™ function description*



*Dahl docking station mounted on the floor*

### **19.3.2 Locking procedure**

Drive the wheelchair slowly into the vehicle and make sure you centre your wheelchair in the middle of the docking module. If well positioned, the locking system will also guide the wheelchair into the docking station. Keep in slowly



driving until you feel the wheelchair is hitting the end position in the docking station. At the same time you will hear a clicking sound. The wheelchair is now locked in to the docking station. The light on the control panel will light up de LED showing the wheelchair is locked in correctly. Now switch the wheelchair off.

 **WARNING**

If the wheelchair is not centered correctly, it might not be possible to lock in top the docking station. In that case, retry by driving a bit backwards and re-center the wheelchair. Try once more until you hear the clicking sound and you see the locked sign LED on.

After the wheelchair is locked in, put the car safety belt on according to the instruction in chapter 19.3.5.

 **WARNING**

Do not forget to put the car safety belts on before driving in the vehicle. This is in order to avoid dangerous situations and personal- or wheelchair damage.

### 19.3.3 Unlocking procedure

To unlock the wheelchair, first open up the car safety belt. Then switch on the wheelchair and switch to drive mode. Now push the release button of the Dahl Docking station. You will hear a firm click. The locking bolt is now retracted and the wheelchair can drive in reverse direction out of the Docking station.

 **NOTE**

After pushing the release button of the Dahl Docking station, the locking bolt is retracted for a certain period of time. After that time, the bolt will lift up again and lock the Docking station. Make sure you drive your wheelchair out of the Docking station in this time window of the unlocked position. If not, you have to push the release button one more time.

### 19.3.4 Manually unlocking in case of electric failure or accident

Dahl Engineering offers two docking stations, the Mk II, and a new power height adjustable called Dahl VarioDock. Please also refer to Dahl Engineering instructions for installation, use and maintenance for the station used.

The Dahl Docking station can be unlocked manually in case of an emergency or if the electric unlocking is failing.



*The release lever on the DAHL DOCKING STATION MK II (Left) and DAHL VARIODOCK™ (Right)*

To unlock the docking station manually, the red lever needs to be pulled to the other side as shown by the arrow in the photo above. This retracts the locking bolt manually so the wheelchair can be released out of the docking station.

#### **WARNING**

In case of a failure of the docking station, contact your local car adaptation company who has built in the device into your vehicle. Only authorized and trained staff is allowed to work on the docking device.

### 19.3.5 Safety belt

If the user is transported in his wheelchair, it is necessary to use a car safety belt to secure the wheelchair user.

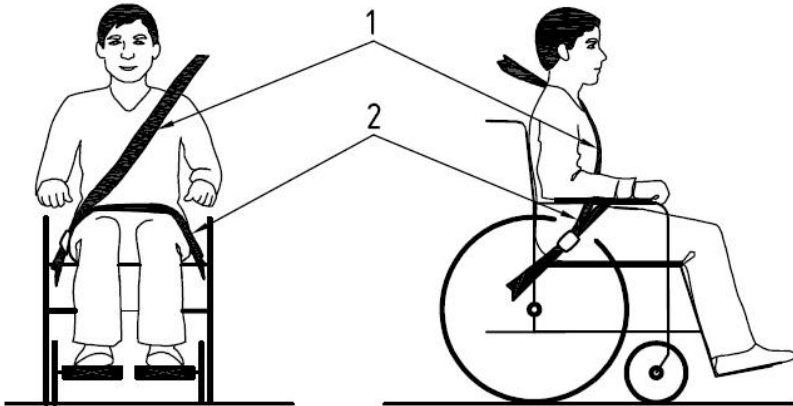

*Positioning of the car safety belts for wheelchair users.*

The wheelchair has been crash tested using a Dahl 3-point occupant safety belt, model 500984. We advise you to use a similar system or a system that is equally specified. It is very important to use the safety belt in the right angles according to the wheelchair user. The angle for the pelvis part (2) of the safety belt must be in angle of 30- 75 ° with the horizontal plane. (See picture below). Also, the side angle should stay between the vertical plane to maximum of 15° angle with the vertical plane. (see picture below).

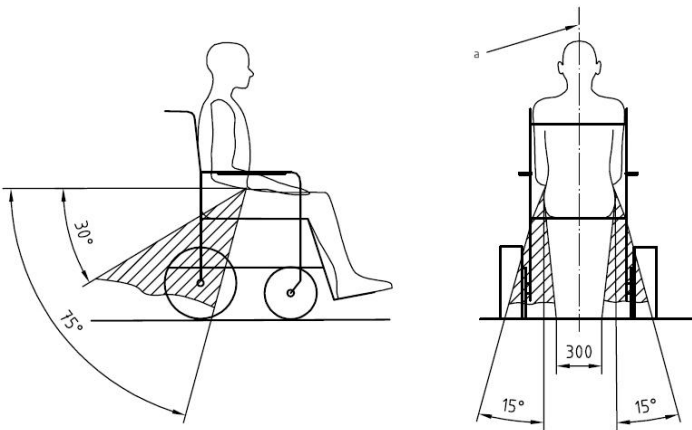

*Optimal angles for a safety belt used by the wheelchair user*

The shoulder part (1) of the safety belt should be positioned according to the figure below.

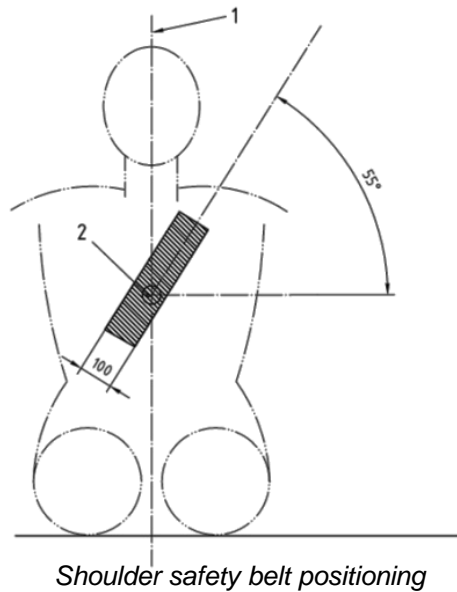

**i** NOTE

Please obtain the following points for an optimal personal safety of the wheelchair user:

- the pelvic belt should be worn low across the front of the pelvis, so that the angle of the pelvic belt is within the preferred zone of  $30^{\circ}$  to  $75^{\circ}$  to the horizontal, as shown in figure above.
- a steeper (greater) angle within the preferred zone is desirable.
- belt restraints should not be held away from the body by wheelchair components or parts, such as the wheelchair armrests or wheels, along with an illustration similar to that of the figure shown above.
- upper torso belts should fit over the shoulder and across the chest, as illustrated in figure of the shoulder safety belt positioning.
- belt restraints should be adjusted as tightly as possible, consistent with user comfort.
- belt webbing should not be twisted when in use.

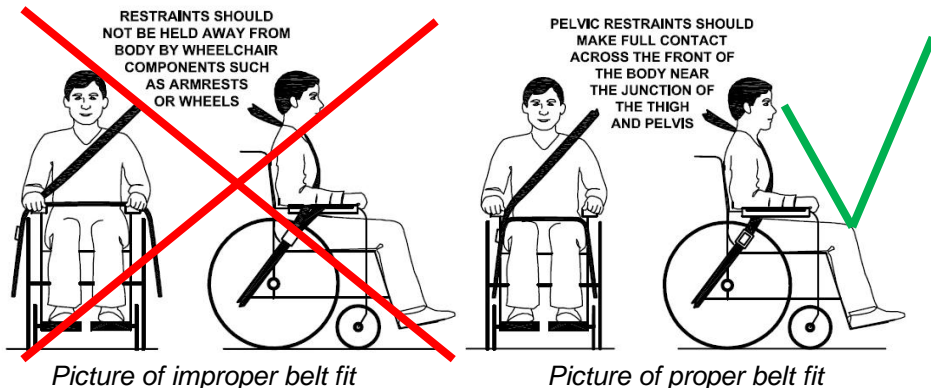

**i NOTE**

Please, make sure the following conditions are fulfilled to obtain a safe transportation:

- **DANGER!** Any wheelchair anchored occupant restraint i.e. 3-point belt, harness or postural supports (lap straps, lap belts) should not be used or relied on for occupant restraint in a moving vehicle, regardless if labeled ISO 7176-19, ISO 10542-1, SAE J2249 or any other. Use a vehicle anchored and certified occupant restraint system instead.
- Whenever possible the occupied wheelchair shall be located in a forward-facing configuration and secured by the tie downs in accordance with the WTORS (wheelchair tie down and occupant-restraint system) manufacturer's instructions.
- This wheelchair is suitable for use in vehicles and has met the performance requirements for travelling forwards-facing in frontal impact conditions. Its use in other configurations within a vehicle has not been tested.
- The wheelchair has been dynamically tested in a forward-facing orientation with the ATD (anthropomorphic test device) restrained by both pelvic and upper torso belts.
- Both pelvic and upper torso belts should be used to reduce the possibility of head and chest impacts with vehicle components.
- When possible, other auxiliary wheelchair equipment should be either secured to the wheelchair or removed from the wheelchair and secured in the vehicle during transit, so that it does not break free and cause injury to vehicle occupants in the event of a collision.

**i NOTE**

- The wheelchair should be inspected by a manufacturer's representative before reuse following involvement in any type of vehicle impact.

### 19.3.6 Positioning the occupant restraint when using it with the Dahl Docking systems only

**! WARNING**

Danger!

When using wheelchair with Dahl Docking systems, the floor anchorage points for the occupant restraint system shall be located 10-60 mm outside wheels, on each side. The pelvic belt must be worn low across the front of the pelvis so that the angle of the pelvic belt is within the optional or preferred zone of 30° to 75° as shown. A steeper (greater) angle within the preferred zone, 45° to 75° is desirable i.e. closer to, but never exceeding 75°.

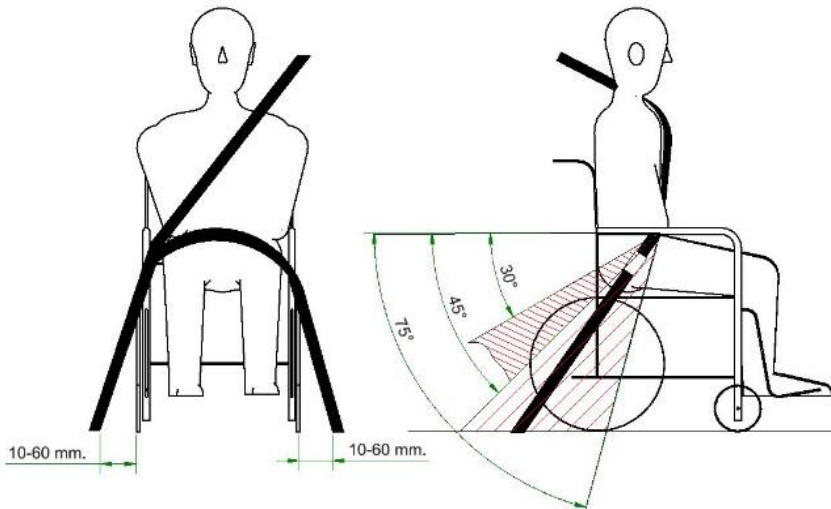

## 20. Maintenance and repairs

The user and attendant have to take care of some maintenance, service and occasionally fault-finding activities. Other activities as described in this paragraph should be carried out under supervision of your authorized dealer.

## 20.1 Battery charging

This wheelchair is provided with two maintenance free batteries. During normal use, the batteries must be charged every day. It is most convenient to make it a daily practice to charge the wheelchair during the night.



### NOTE

- Only charge in a well-ventilated room with no sources of open fire.
- Turn of the control unit before charging
- Make sure the charging cable is not causing crashes of people
- When the charger is disconnected from the wheelchair, also disconnect the charger from the mains.
- Place the charger in a place where it can radiate its heat freely during charging

After having taken care of these precautions, charge the batteries by plugging in the charger in the rear of the control unit first. Plug in the charger in the mains secondly. Read the manual of your charger carefully for any other precautions and user prescriptions. When the wheelchair is not used over a longer period, recharge the batteries every four weeks to keep the batteries in good condition. If the batteries are not charged regularly, the remaining capacity will quickly drop.

## 20.2 Short term storage

For the charging process to produce a battery with good capacity, the temperature in the storage room should not be lower than +5 degrees. If it is stored at a temperature below +5 degrees, there is a higher risk that the battery has not been fully charged when it comes to be used and also a higher risk of corrosion.

## 20.3 Long term storage

The battery may be stored in an unheated room, but it should be charged at least once a month for maintenance purposes.

 **NOTE**

When the wheelchair is stored for a long term, we advise you to disconnect the batteries from the wheelchair. This way the batteries will hold their energy for a longer period.

When re-using the wheelchair, the batteries will be installed and fully charged.

Ask your local authorized supplier to store and maintain the batteries if they are not used for a long period (more than two months.)

 **NOTE**

- Please note that a battery discharges itself and that a discharged battery can burst when it is cold. If the wheelchair is to be stored unused for an extended period of time, the batteries must always be charged once a month to avoid them being damaged.
- The wheelchair must not be stored in areas subject to condensation (steam or moisture on surfaces), for example utility rooms or similar.
- The wheelchair may be stored in an unheated room. From the point of view of corrosion, it is best for the room to be a few degrees warmer than the surroundings as this keeps the room drier.
- If the wheelchair is fitted with acid batteries, the acid level should be checked regularly. If the wheelchair is fitted with gel batteries, the liquid level does not need to be checked.
- The life of the batteries depends entirely on regular charging.

 **WARNING**

Be careful when using metal objects close to the batteries. A short circuit might easily create strong sparks and can cause a fire. Should you need to work on the batteries, use isolated tools and wear protective gear on hands and eyes.



## 20.4 Tools

The wheelchair comes with a tool kit to be able to adjust most settings.

### NOTE

Some repairs may require tools other than those supplied with the wheelchair.

### WARNING

The main fuse must always be removed when batteries are replaced. Always switch off the power supply to the control panel before interrupting the power with the main fuse.

### NOTE

Any unauthorized alterations to the wheelchair and its systems may lead to an increased risk of accident. All alterations to and interventions in the wheelchair's vital systems must be performed by an authorized service engineer. In case of doubt, always contact an authorized service engineer.

### WARNING

Damage caused by self servicing or servicing by unauthorized personnel cannot be claimed under warranty!

If you have any doubt in the capability of yourself or the service engineer, please contact your local authorized supplier to help you.

## 20.5 Wheels and tires

Check at regular intervals that the wheelchair's tires have the correct tire pressure. Check regularly that the tire pressure is okay. We suggest checking the tire pressure at least every 4 weeks.

Type of tire	Tire size	Recommended. pressure
Front tire	2.50/2.00-4	40 PSI, 2.8 Bar, 275 Kpa
Middle tire	3.00-8	35 PSI, 2.4 Bar, 240 Kpa

### WARNING

An incorrect tire pressure may result in lower stability and maneuverability. Too low tire pressure also results in abnormal wear and shorter driving range.

### 20.5.1 Puncture repair

Since the wheelchair is rather heavy, it is recommended to let your authorized supplier repair eventual tire punctures. First lift the wheelchair so that the punctured tire is free from the ground. The middle wheel tires can be taken off by loosening the 3 bolts (B) which hold the wheels on to the wheelchair. **DO NOT LOOSEN THE CENTER BOLT (C).**

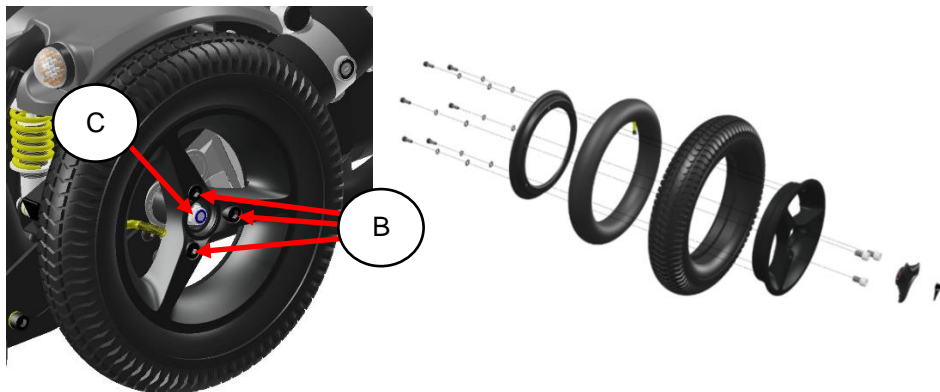

*Exploded view of middle (driving) wheel*

The front wheel tires can be taken off by loosening the center bolt (D) which hold the wheels on to the wheelchair.

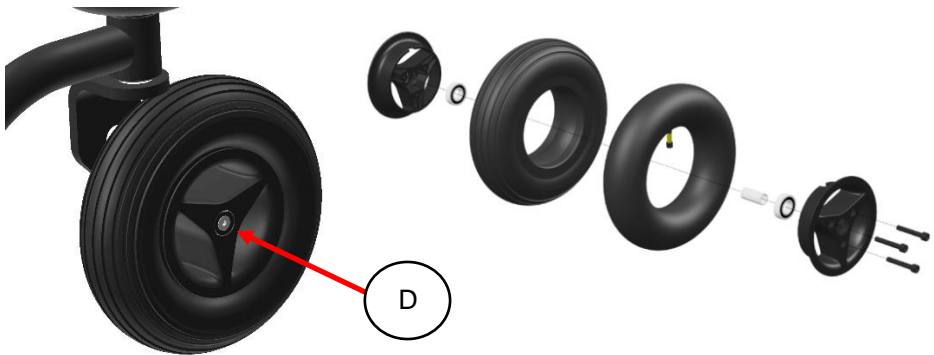

*Exploded view of front wheel*

After taking the wheels of the wheelchair the rim can be split. The tire is then available for repair. The inner tubes of the tires can be repaired according to the description on the tire puncture repair kit that you use. It is however recommended to renew the inner tube at all time when the tube has a puncture.

**i NOTE**

After re-assembling the wheel, you should mount the wheel onto the motor or rear fork and secure the bolts with blue Loctite.

## **20.6 Cleaning**

Regular care and maintenance will prevent unnecessary wear and damage to your wheelchair. The following is general advice recommended by Karma. For severe soiling of the upholstery or damage to the surface finish, contact Karma or your local authorized supplier for information.

### **20.6.1 Upholstery, cloth / air mesh**

For normal cleaning, wash the upholstery with hand warm water and a mild nonabrasive soap. Use a soft cloth or brush. Before the surface dries, wipe off any water/soap residues with a clean, dry cloth. This procedure may be repeated to remove stubborn dirt or stains.

If necessary, the cover may be removed before cleaning. See also the washing instructions on the label of the upholstery materials.

## 20.6.2 Metal surfaces

For normal cleaning it is best to use a soft cloth/sponge, hand warm water and a mild detergent. Wipe down carefully with a cloth and water and dry off. Remove scuff marks from semi-matt surfaces with soft wax (follow manufacturer's instructions).

Remove scuff marks and scratches from shiny surfaces using car polish, either liquid or paste. After polishing, apply soft car wax to restore the original surface gloss.

## 20.6.3 Plastic covers

For normal cleaning, wash plastic surfaces with a soft cloth, mild detergent and hand warm water. Rinse thoroughly and dry with a soft cloth. Do not use solvents or abrasive kitchen cleaners.

### WARNING

Never use aggressive chemical cleaner or cleaning fluids. These will damage the surface and structure of the material.

### WARNING

Never use a high pressure water hose or steam cleaner. This will damage the surface and structure of the material and could cause electronic failure.

### WARNING

Never use a sponge with a hard surface. This will damage the surface and structure of the material.

## 20.7 Brake release, freewheel mode

Check regularly, approximately once a month, that the brake release and the brake release lever is working properly.

When the brakes are released, it should not be possible to drive the wheelchair.



## 20.8 Battery replacement

Karma strongly recommends that battery replacement and installation always be done by a qualified technician. To replace the batteries, please refer to the photos below of the batteries equipped on the Morgan M series, and follow the below instructions to remove and load the batteries. The weight of one battery could be more than 10 kg. Please handle it with care.

### WARNING

- Do not turn off the power of the wheelchair before replacing or loading the batteries.
- Do NOT allow conductive material such as a wrench to contact BOTH battery terminals at the same time. This will result in a short that can cause burns to you and damage the battery.
- Most batteries are not sold with instructions. However, warnings are frequently noted on top of the batteries. Read them carefully.
- Do NOT allow the liquid in the battery to come in contact with skin, clothes or other items. It is a form of acid and may cause harmful or damaging burns. Should the liquid come into contact with skin, rinse the area immediately and thoroughly with cool water. If liquid comes into contact with eyes, flush eyes immediately and seek medical attention as soon as possible.
- The use of rubber gloves and chemical goggles are recommended when working with batteries.
- NEVER smoke or strike a match near the batteries.
- Replace the batteries IMMEDIATELY if there are any cracks or leaks.

### 20.8.1. Replacing the batteries (Front side)

Step1: use the flip-up mechanism to tilt the chair back first.



Step 2: remove the bolts (A) of the front cover in the front of the wheelchair. Detach the front cover and lift it off.

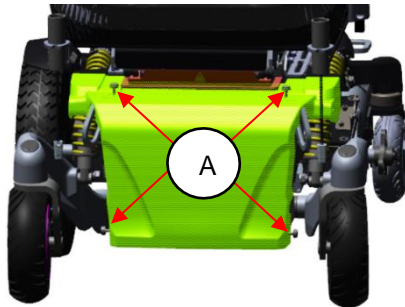

Step 3: remove the screws (B) of the front battery plate and then detach it.

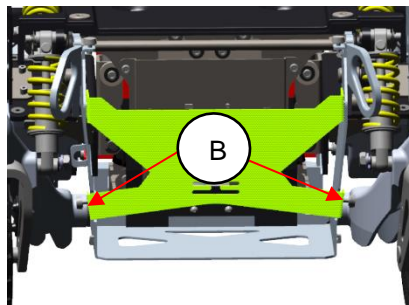

Step 4: unfasten the fixing straps (C) of the battery box. Then hold the battery and slightly pull it out. Unplug the connector (D) of the main power cable. Disconnect the cables (E) from the positive and negative poles.

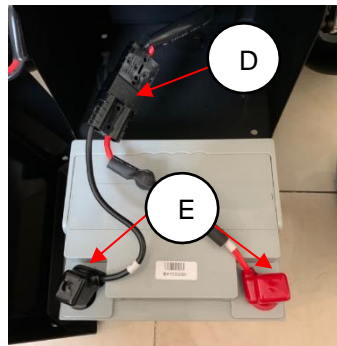
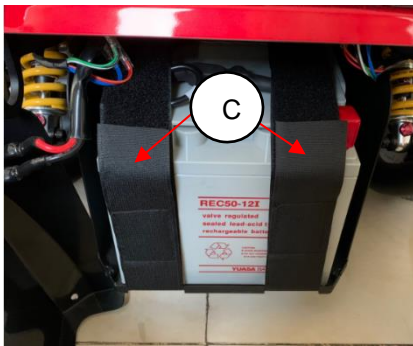

**WARNING**

Although the batteries maybe broken, still be very careful when touching the battery connection poles. Avoid any risk of short circuit between both poles.

Step 5: take the new battery and then connect the cables on to the positive and negative poles.

Step 6: connect the cables to the main power cable and then place the battery into the front of the battery box.

Step 7: fasten the fixing straps and then mount back the front battery plate.

Step 8: place the front cover back and secure it with the bolts.

## 20.8.2 Replacing the batteries (Rear side)

Step 1: remove the bolts (F) of the rear cover in the rear of the wheelchair. Detach the rear cover and lift it off.

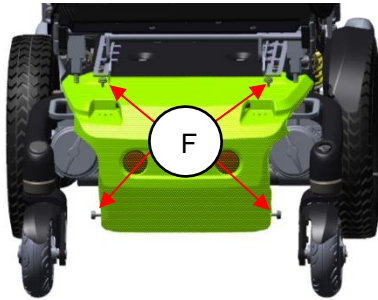

Step 2: disconnect the connectors (G) of the rear light / direction light assembly.

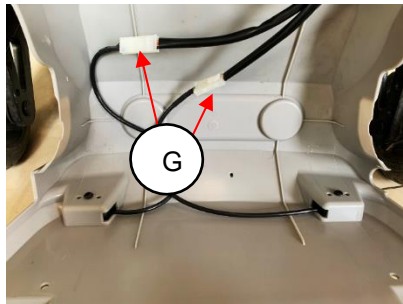

Step 3: remove the screws (H) of the rear battery plate and then detach it.

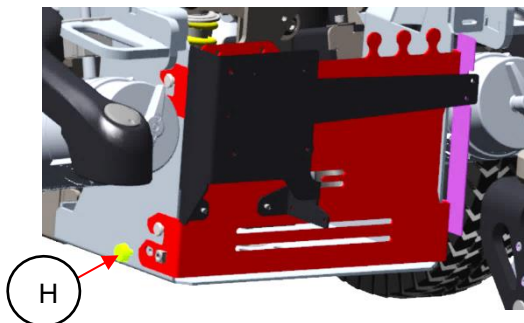



Step 4: unfasten the fixing straps (I) of the battery box. Then hold the battery and slightly pull it out. Unplug the connector (J) of the main power cable. Disconnect the cables (K) from the positive and negative poles.



Step 5: take the new battery and then connect the cables on to the positive and negative poles.

Step 6: connect the cables to the main power cable and then place the battery into the rear of the battery box.

Step 7: fasten the fixing straps and then mount back the rear battery plate.

Step 8: place the rear cover back and secure it with the bolts.

### 20.8.3 Disposal of the batteries

 **WARNING**

There are many risks involved with improper disposal of batteries, whether damaged or not. Batteries may contain heavy metals and be considered hazardous waste.

Many regions around the world now strictly enforce laws to help protect our environment. By not disposing of batteries properly, you may be liable for fines from your local through national government.

By not recycling batteries, they end up in landfills where lead and other chemicals may leach into streams and rivers destroying ecosystems and poisoning local water resources.

Improper disposal of batteries may also cause injury to unsuspecting others that come in contact with them. If you come in contact with fluids or corroded powder from a battery, rinse with water and contact a physician if necessary. If contact with eyes occurs, rinse for 15 minutes and then visit a physician.

**DO NOT** incinerate or burn the battery. It will cause it to explode!

Please see the chapter of: Disposal of the product

 **WARNING**

If you are not capable of replacing the batteries by yourself or you don't feel comfortable doing it, please contact your local authorized supplier for help.

 **WARNING**

Damage on the wheelchair as a result of a not proper repair or replacement is not covered by our product warranty.

 **WARNING**

Batteries are classified as chemical waste and need to be disposed according to the local regulations for chemical waste.

## 21 Refurbishment and re-use of the product.

This wheelchair is suitable for refurbishment and re-use. This means that, if the wheelchair is not used anymore by the first user, it can be refurbished to fit another user. Should you not be able to use the wheelchair any longer, we strongly recommend you contact your local authorized supplier to have it picked up for refurbishment and re-use.

### **WARNING**

The refurbishment of the wheelchair is only allowed to be executed by an authorized supplier.

### **WARNING**

If the wheelchair is refurbished by a non-authorized supplier or institute, Karma Medical cannot be held responsible for this product, and all warranty claims will be voided.

### **NOTE**

The wheelchair will be refurbished according to a refurbishment guideline of Karma. This includes the replacement of all upholstery parts, a total disinfection of the product and a complete technical check of the wheelchair and its accessories.

## 22 Disposal of the product

In the case of disposal of the used wheelchair you need to follow the local legal regulations for disposals.

We strongly recommend you contact your local authorized supplier to take care of the disposal of your wheelchair.

### **WARNING**

Batteries are classified as chemical waste and need to be disposed according to the local regulations for chemical waste.

## 23 Trouble shooting

The following troubleshooting guide describes a number of faults and events which may occur when you use your wheelchair, together with suggested remedies. Note that this guide cannot describe all the problems and events which may occur, and you should always contact your local authorized supplier or Karma in case of doubt.

Event	Possible Cause	Remedy
The wheelchair does not start up	Batteries discharged.	Charge the batteries
	The cable connection of the control panel has come loose	Reconnect the cable
	Main fuse is defect	Replace main fuse Check first!!!
Wheelchair doesn't drive	Charge still connected	Disconnect charger
	Brake release activated	De-activate brake release
	Wheelchair locked	Unlock the wheelchair
The wheelchair switches itself on after a certain while	The energy saving mode has been activated	Restart wheelchair using the on/off button
The wheelchair stops whist being driven	A cable connection of the R-net system has come loose	Check all R-net connections and restart
	Main fuse has triggered	Replace main fuse Check first!!!
The wheelchair only drives at reduced speed	A speed reducing inhibit is activated	Move the seat into a position where max. Speed is allowed.
	Gyro has been disconnected	Re-connect gyro Need service!!
Certain powered seat function is not displayed in menu	Cable connection of seat function in disconnected	Call for service
	Seat function motor defect	Call for service
Wheelchair cannot be charged	Main fuse disconnected	Re-install main fuse
	Main fuse has triggered	Replace main fuse Check first!!!
	Connection between charger and joystick module not good	Check connection  Call for service

Note that this guide cannot describe all the problems and events which may occur and you should always contact your local authorized supplier or Karma in case of doubt.

## 23.1 Diagnostics VR2













When an error or a fault occurs in the wheelchair's electronics, information on it is displayed in the control panel's display. This information can then be used to diagnose where the error/fault occurred and its cause.

Troubleshooting and repairs must always be performed by authorized personnel with good knowledge of the wheelchair's electronics.



### WARNING

Incorrect or poorly performed repair works may make it dangerous to use the wheelchair. Karma accepts no liability for any personal injury or damage to the wheelchair and its surroundings that occurs because incorrect or poorly performed repair work.

Indication	Status	Meaning	What to Do
	1 signal	The battery needs charging or there is a bad connection to the battery.	Check the connections to the battery. If the connections are good, try charging the battery.
	2 signals	The left hand motor has a bad connection.	Check the connections to the left hand motor.
	3 signals	The left hand motor has a short circuit to a battery connection.	Connect your service agent.
	4 signals	The right hand motor has a bad connection.	Check the connections to the left hand motor.
	5 signals	The left hand motor has a short circuit to a battery connection.	Connect your service agent.
	6 signals	The wheelchair is being prevented from driving by an external signal.	Please remove the charger.
	7 signals	A joystick fault is indicated.	Make sure that the joystick is in the center position.
	8 signals	A joystick fault is indicated.	Make sure that all connections are secure.
	9 signals	The parking brakes have a bad connection.	Check the parking brake and motor connections and make sure all connections are secure.
	10 signals	An excessive voltage has been applied to the control system.	Check the battery connections.
	7 signals + S	A communication fault is indicated.	Make sure that joystick cable is securely connected and not damaged
	8 signals + A	An actuator trip is indicated.	If more than one actuator is fitted check which actuator is not working correctly. Check the actuator wiring.

## 24 Technical specifications



**DATA**

**General**

product name Morgan M Sling (MGNM-SLN)  
 wheelchair class Class B (indoor/outdoor use)  
 expected service life > 5 years

**Sizes**

	min.	max.
length, mm	1090	1120
width, mm	630	690
height, mm	960	
weight, kg	128.5 (50Ah)	151 (80Ah)
horizontal location of axle, mm	(-85)	(-35)

**Smallest size for transportation**

length, mm	800
width, mm	630
height, mm	920
mass of the heaviest part, kg	94.5

**Wheels**

size front	2.50/2.00 -4 (8")
size middle	3.00 -8 (14")
size rear	2.00/1.00 -4 (6")
tire pressure	40 PSI, 2.8 Bar, 275 Kpa
front	35 PSI, 2.4 Bar, 240 Kpa
middle	

**Performance**

	min.	max.
speed, km/h	6	12
drive range, km (depending on size of batteries)	27 (50Ah)	49 (80Ah)
minimum turning area, mm	1260	
minimum turning radius, mm	700	
obstacle climb, mm		75
static stability	downhill 17°	
	uphill 12°	
	sideways 20°	
dynamic stability	uphill 6°	
	downhill 6°	
	sideways 6°	
breaking distance from max. speed, mm	1900	

**Seat**

effective seat depth, mm	390	515
effective seat width, mm	415	465
seat angle, in degrees	0	20
seat surface height (seat pan to ground)	420	
maximum user weight, kg		136
backrest angle, in degrees	90	120
backrest height, mm	465	515
footrest to seat distance, mm	380	485
legrest to seat angle, in degrees	105	
armrest height, mm	190	290
front location of armrest structure	190	520

**Electronics**

voltage	PG drives Technology
power	24 volts
joystick module	PM90
	VR2

**Batteries**

type	rechargeable, maintenance free	YUASA, 50Ah
	rechargeable, maintenance free	YUASA, 80Ah
charging time (depending on size of batteries)		8-10 hours

**Fuse**

main fuse	80A
-----------	-----



The wheelchair conforms to the following standards:

- a) Requirements and test methods for static, impact and fatigue strengths (ISO 7176-8)
- b) Power and control systems for electric wheelchairs – requirements / test methods (ISO 7176-14)
- c) Climatic test accordance with ISO 7176-9
- d) Requirements for resistance to ignition in accordance with ISO 7176-16
- e) crash test with 4 point-tie-down according to ISO 7176-19:2022
- f) crash test with Dahl docking system according to ISO 7176-19:2008

## **25 Accessories**

Accessories for Karma power wheelchairs are subject to continuous development. Every day we design new accessories to improve the flexibility of our products.

Contact your local authorized Karma supplier for more information on the accessories which are available for your wheelchair.

Should you have a good suggestion for a new accessory, do not hesitate to contact us. Your idea might be the next new accessory!

### **Worldwide:**

Karma Medical  
NO.2363, Sec. 2  
University Road  
Min-Hsiung Shiang  
Chia-Yi 621, Taiwan  
[www.karmamedical.com](http://www.karmamedical.com)  
[globalsales@karma.com.tw](mailto:globalsales@karma.com.tw)

### **European representative :**

Karma Mobility Spain S.L.  
C/ Periodista Francisco Carantoña Dubert,  
23 Bajo 33209 Gijón - Asturias (Spain)

phone: +35 984 39 09 07  
mail: [karma@karmamobility.es](mailto:karma@karmamobility.es)  
web: [www.karmamobility.es](http://www.karmamobility.es)

NOTES:

## **We have a big dream**

Whether it's a customized wheelchair, standing chair, general purpose chair, or another mobility aid device, each of our products is carefully designed with our customers' voices, needs, and desires in mind.

When it comes to user experiences, we strive to be more "caring," "empathetic," and "approachable."

Through our dedication and our mindfulness, we look forward to bringing more confidence, joy, and love for life to those with physical disabilities around the world.

*we look forward to bringing more confidence, joy, and love for life to those with physical disabilities around the world.*

Karma Medical is continuously improving their products and accessories. Changes might take place without further notice.

# karma

A Better Wheelchair, A Better Fit



KARMA MOBILITY S.L European Support Center.  
[www.karmamobility.es](http://www.karmamobility.es)  
+34 984 390 907  
[karma@karmamobility.es](mailto:karma@karmamobility.es)

KARMA MEDICAL PRODUCTS CO., LTD.  
[www.KarmaMedical.com](http://www.KarmaMedical.com)  
+886 5 206 6688  
[globalsales@karma.com.tw](mailto:globalsales@karma.com.tw)

110400001193 Release Date: Jan. 2023 V.03