



USER'S MANUAL

LS

MULTIFUNCTIONAL ELECTRIC WHEELCHAIR

Revision Sheet

| Revision No. | Date | Revision Description |
|--------------|------------|--|
| Rev. 1 | 11.08.2020 | Modification of the chapter 4. |
| Rev. 2 | 02.12.2020 | Addition to chapter 4 - Adjustment armrests. |
| Rev. 3 | 22.10.2021 | Adjustments to the User's Manual. |
| Rev. 4 | 27.06.2022 | Adjustments to chapter 3, 9 and 13. |

Serial number label for this LS

CONTENTS

| | |
|---|-----------|
| 1. PRELIMINARY NOTE | 7 |
| <hr/> | |
| 2. IMPORTANT SAFETY INSTRUCTIONS | 8 |
| <hr/> | |
| General safety instructions | 8 |
| Notes on EMC interference | 8 |
| Brakes | 8 |
| Intended Use | 8 |
| Indications | 8 |
| Contraindications | 8 |
| Declaration of Conformity | 8 |
| 3. PRODUCT OVERVIEW | 9 |
| <hr/> | |
| Delivery | 9 |
| Check the delivery | 9 |
| Identification label | 9 |
| Overview LS | 9 |
| Symbol explanation | 9 |
| 4. USE OF THE WHEELCHAIR | 10 |
| <hr/> | |
| Basic settings | 10 |
| Control | 10 |
| Adjustments and equipment | 12 |
| Getting in and out | 16 |
| 5. TECHNICAL SPECIFICATIONS | 17 |
| <hr/> | |
| Batteries | 19 |
| Charging | 19 |
| Care and maintenance | 20 |
| Service information | 20 |
| 6. EXAMINATION OF THE WHEELCHAIR | 21 |
| <hr/> | |
| Checking the brakes | 21 |
| Checking the tires | 21 |

| | |
|---|-----------|
| 7. CLEANING AND DISINFECTING | 22 |
| Cleaning | .22 |
| Disinfection | .22 |
| Re-use of the wheelchair | .22 |
| 8. MAINTENANCE | 23 |
| Replacing the batteries | .23 |
| The power supply of the wheelchair | .23 |
| Repair/maintenance plan | .23 |
| 9. TRANSPORT | 24 |
| Guideline for transportation in a vehicle | .24 |
| Transportation using Dahl Docking station | .27 |
| Brackets for attaching the wheelchair | .28 |
| 10. STORAGE | 29 |
| 11. DISPOSAL | 29 |
| 12. WARRANTY | 30 |
| 13. PRE-SALE INFORMATION | 31 |
| 14. MANUFACURER | 34 |

1. Preliminary note

Thank you for purchasing a LS multifunction electric wheelchair. The LS can be optimally adapted to your physical needs. All settings can be adjusted electronically, steplessly via the joystick. You can adjust seat height, seat angle, backrest angle, knee angle, armrest position, footplate position and leg length. Its size combined with its high functionality makes it ideal for indoor and outdoor use.

Please charge the battery completely before first use, see Chapter "Charging". To get the most out of all the benefits of this wheelchair, read the instructions carefully, do not throw it away, but keep it handy. Maintenance work or technical repairs may only be carried out by authorized specialist dealers.

LS is a Class B electric wheelchair designed for use in- and outdoors.



LS

2. Important safety instructions

General safety instructions

- To avoid falls and accidents, it is important to familiarize yourself with your new wheelchair in a safe environment, on a level surface. We recommend that you bring a companion in the beginning.
- When adjusting the wheelchair there is a risk of entrapment for the user as well as for third persons who are in the immediate vicinity of the wheelchair.
- Avoid driving against steps or curbs.
- When transporting the wheelchair, it must be secured against rolling away. Use the fastening devices.
- In the event of prolonged exposure to the sun, parts of the wheelchair may heat up, there is a risk of burns.
- Weight transfer due to body movement or load may increase the risk of tipping.
- Please do not hang objects such as carrying bags, backpacks etc. on the wheelchair, this is not intended. Attached loads, change the statics and can lead to falls and modified braking behavior.
- When driving on uphill or downhill gradients, make sure that the seat surface is not raised as this will limit the stability and can cause the wheelchair to fall over.
- Note that the braking distance is longer on inclines than on level ground.
- When overcoming slight obstacles or height differences, you should raise the seat slightly, if at all, and leave the backrest as steep as possible to prevent the wheelchair from tipping over.
- Do not bring damaged batteries into contact with skin, as the contents of the battery are harmful to health and can be corrosive.
- Only charge the battery in ventilated areas.



Be sure to keep your arms and hands on the armrest during electrical adjustment of the wheelchair. Third parties should not touch the marked areas with their hands or fingers.

 **ENTRAPMENT!**

Notes on EMC interference

While all EMC directives have been met, the electric wheelchair may be affected by other electrical systems or interfere with these, such as electric motors, electric doors, alarm systems, mobile phones, and other electrical systems that emit EMC noise. It may also be so that the wheelchair can disturb other electrical systems.

Brakes

The wheelchair brakes to a halt when the joystick is released. The functionality should be checked before each use.

Attention: *On gradients, the braking distance is extended.*

Intended Use

The wheelchair is exclusively for the transport of disabled persons.

Indications

Inability to walk or severe disability caused by:

- paralysis.
- joint contractures, joint damage - not on both arms.
- loss of limbs.
- limb injury.

The use of an electric wheelchair is intended for persons who, due to the disability, are unable to operate hand-driven wheelchairs, but have the ability to properly operate the electric wheelchairs.

Contraindications

Electric wheelchairs are unsuitable for people:

- with reduced eyesight.
- with severe balance disorders.
- with severe limitations of cognitive abilities.
- with inability to sit.

Declaration of Conformity

NHD, as the manufacturer, declares on its sole responsibility that the LS electric wheelchair complies with the requirements of EU MDR Regulation 2017/745.

3. Product Overview

Delivery

After receiving your goods, please check the contents for completeness:

- Packaging.
- Electric wheelchair.
- Control device.
- Charger.

Check the delivery

Your LS wheelchair is delivered ready for use, no further assembly is necessary.

Please check if all listed elements are present.



Identification label

The identification label is located behind the right drive wheel.



NHD AS 2021-01-01
 Gigstads vei 22, 3511 Hønefoss, Norway
 GTIN: 7090053360001
 Type: LS
 Modell: LS
 SN: 210101-xxxxxx



  **MAX 136 Kg**  **max. 6°**

 See user manual or www.nhd.as



- Manufacturer.
- Model.
- Serial number.
- Max. user weight.
- Max. safe gradient.
- CE mark.
- Production date.
- QR code.

Overview LS



| | |
|---|--|
| A | Headrest |
| B | Backrest |
| C | Armrest |
| D | Electrical control with connection for the charging unit |
| E | Seat cushion |
| F | Footrest |
| G | Rear Wheel |
| H | Front Wheel |
| I | Footrest Plate |
| J | Battery Unit |
| K | Identification lable |

Upon request, your wheelchair will be delivered with a lap belt, which is attached to the side of the seat plate. This belt does not serve as a safety belt during car rides. To close, push the two belt parts into each other until they click into place. Open the clasp by pressing on "Press". For optional parts contact our authorized dealers.

Symbol explanation



UNLOCK / LOCK



Indicates freewheel function



Approved label



Securement point



Main fuse



DO NOT LEAVE THE CHAIR UNLOCKED
Danger symbol



Danger of entrapment



Electricity



Indicates not for recycling

4. Use of the wheelchair

Basic settings

The individual mechanical adjustments before the first use of your electric wheelchair, must be made by the authorized dealer. Such settings may affect the stability of the chair.

The LS has as a standard control systems/joystick module CJSM-L-SW.

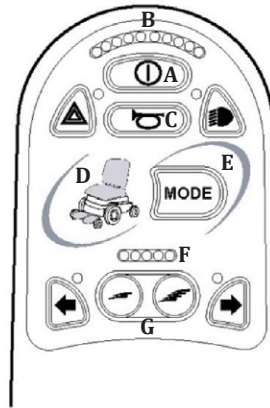
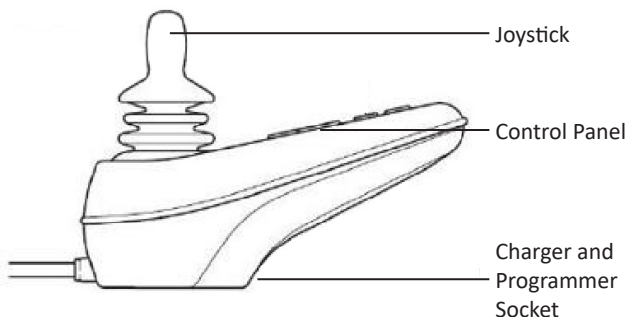

- A. On/Off switch.
- B. Charge level.
- C. Signal horn.
- D. Display of the areas to be set.
- E. Mode key to change the areas to be set.
- F. Display of the max. speed.
- G. Option key for determining the speed in the driving profiles.

Control

With the control you control the settings of your wheelchair, as well as the driving characteristics.

The control offers the possibility to electronically adjust the seat adjustment, it is located on the right armrest and can be operated with little force.

⚠ PLEASE READ CAREFULLY THE SAFETY INSTRUCTIONS BEFORE FIRST USE.

Press the upper button to turn on the controller.

The "Mode" button takes you to the two main menus, setting mode or driving mode.

Attention: LS has an alternative control systems/joystick modules.

The LS can be supplied with the Joystick Modules CJSM2

- Large, high-resolution 3.5" VGA color display.
- Infra-Red (IR) Control as standard.
- Integrated Bluetooth control as an option.
- Stylish and ergonomic design.
- Built-in light sensor to automatically adjust screen brightness.
- Paddle switches for easy access to user controls.
- Enhanced programming and customization options.
- Speaker for enhanced horn volume.
- Metal case for improved robustness.
- Connect-and-Go.

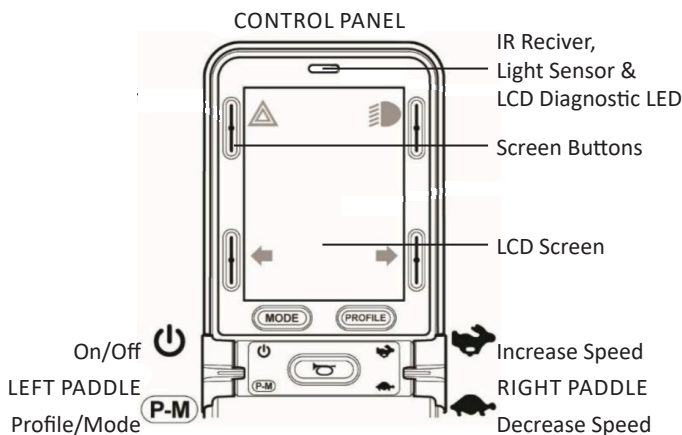
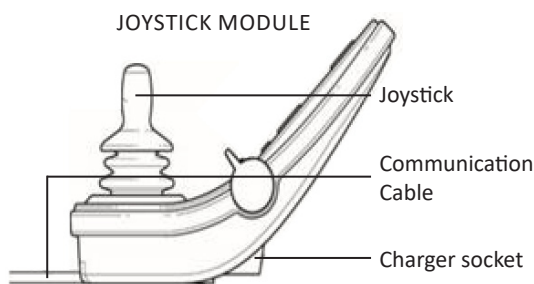

EXTERNAL JACK SOCKETS

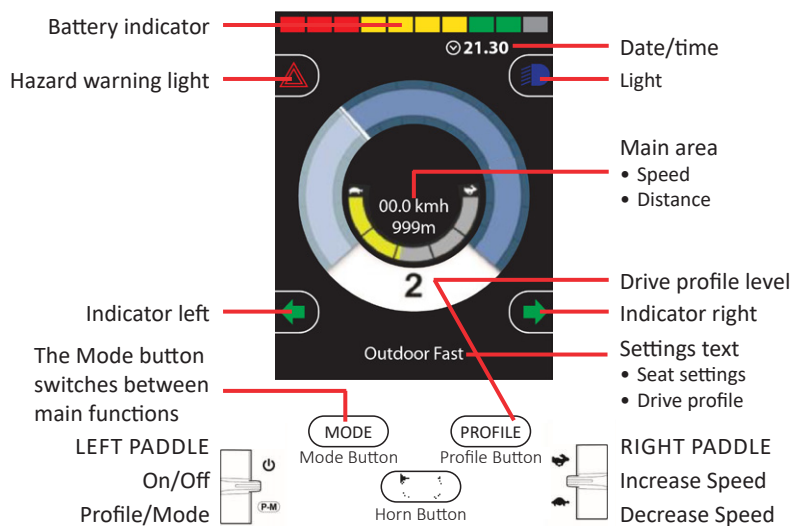
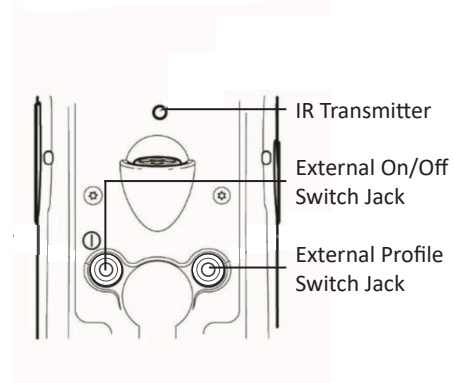

Adjustments and equipment

Setting

Attention: Please note that major changes, such as extreme positioning of the backrest or leg rest and/or high height adjustment, can negatively affect the stability. Also, the braking distances can be extended. If you have any questions, please consult your dealer.

If one or more areas of the wheelchair lights up in the display next to the Mode button, you are in setting mode. With a right or left movement of the joystick you can switch between the areas to be set. If you move the joystick forwards or backwards in this mode, you change the position of the illuminated areas. Total range of motion for seat functions depend on seat unit chosen.

The following ranges can be infinitely adjusted via the control:

- Backrest at an angle.
- Seat angle.
- Length of legrests.
- Angle of legrests.
- Seat height.

Seat angle / tilt adjustment

When seat height is from 340 mm (lowest) to approx. 450 mm max. seat tilt is from 0° to approx. 15°. At seat height from 450 mm to 600 mm, the seat can be tilted 0° to 45°. To ensure good stability, there is no wheel drive when the chair is tilted more than 15°.



Backrest.



Seat angle.



Length of legrest.



Angle of legrest.



Seat height.

Driving mode

If you press the on/off switch, if no areas in the display next to the mode button light up, you are in driving mode.

When you move the joystick forward, the wheelchair moves forward. By releasing the joystick the wheelchair comes to a standstill.

To change from the setting to the driving mode, proceed as follows:

- Press the “Mode” button, move the joystick to the right (or left) until no areas in the display next to the “Mode” button light up.

Speed

The speed is controlled while driving with the joystick, if you move the joystick only slightly, the ride is slower. Push the joystick to the stop to drive at maximum speed. The maximum speed can be set in advance in three different driving profiles (see section driving profiles).

Set driving profiles

Driving profiles are adapted for different driving conditions. There are 4 drive profiles:

1. Indoor no Gyro
2. Indoor
3. Slope driving
4. Flat fast driving

- Profile 1 is suitable when driving on moving surfaces such as inside a ship.
- Profile 3 is recommended for driving on slopes.
- Profile 4 is also best fitted when climbing obstacles.

Change of direction

If you move the joystick to a side position while driving, the wheelchair follows and moves in that direction.

For reversing, move the joystick towards you.

Attention: The wheelchair has a low turning radius, make sure that no people or objects are too tight and that you or others are not injured.

Attention: Please make sure that there are no persons or obstacles behind you.

Overcoming obstacles

To climb up kerbs, steps or other use ramps or lowered areas. If not possible, drive slowly and head-on towards the obstacle to be overcome, staying about 50 cm in front of it. Make sure the wheels are perpendicular to the obstacle. Now drive at a steady, sufficient speed over it.

Attention: Do not try to drive over obstacles higher than 50 mm. Do not drive over the obstacle at an oblique angle, there is a risk of tipping.

Steep terrain

Note that the maximum slope you can drive it 6°. If you drive forward tilt the seat backwards and be sure that you're leaning backwards as far as possible. Select a Mode with reduced speed and brake softly.

Freewheel function

The power wheelchair can be set in a manual sliding mode. This function may only be set by a companion. The following step is necessary for this:

- Loosen the center handles on the brake release handles (“Unlock” and “Lock”).



Freewheel function.

Attention: The wheelchair has no braking function in sliding mode.

The controller is automatically switched off in this mode.

After the shift, switch the system back to normal operation. If the controller is not yet active, switch it off and on again, now your electric wheelchair is again driveable.

Lock with the help of the controller

To secure the control, please proceed as follows:

- Press the ON button until a beep sounds. Release the button and slide the joystick forwards until you hear another beep. Release the joystick. Then move the joystick backwards until you hear another beep, release the joystick and a long beep sounds. The electric wheelchair is now locked against driving away.
- To unlock the wheelchair, follow the same procedure.

⚠ WARNING:

Contact suitable service personnel if you need adjustment of the chair's technical settings and for programming/adjustment to the software. Danger of user and mechanical failure!

Adjustment seat and backrest

The wheelchair seat are designed to optimize the seating comfort of the user. It can be adjusted in seat depth and seat width. The seat depth is adjusted with screws (A) on the underside of the tilting frame. The chair can be configured so that the seat depth is from 380 mm to 580 mm at 25 mm intervals. At seat depths of 380 mm to 430 mm, brackets for back mounting must be replaced (see drawing and table to the right).

A rail on each side provides mounting points for accessories such as hip supports or seat belts. The seat base is flat, so that the seat cushion itself can be mounted on the seat unit.

The backrest is available in different lengths and widths to give the user maximum support and comfort.

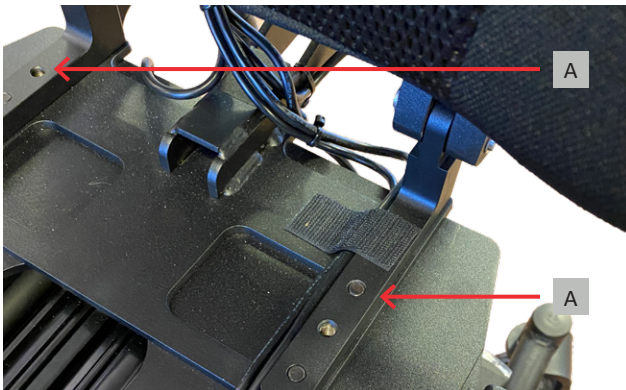

Screws for adjusting the seat depth seen from the top of the tilt frame.



Screws for adjusting the seat depth on the underside of the tilt frame.

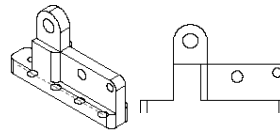

Rygg brakett LS
Back bracket LS



| Pos. | Art. | Ant./ No. | Beskrivelse | Description |
|------|--------|-----------|---|---|
| 1 | 102695 | 2 | Rygg brakett, kort setedybde 380 - 430 mm | Back bracket, short seat depth 380 - 430 mm |

Armrests

The armrests can be folded up completely to make getting in easier.



Height adjustment armrest

Height adjustment is made by shortening the Adjustment Sleeve (A) (raising the armrest) or extending (lowering the armrest) using the inner threaded rods in it. Unscrew the lower attachment (B) and loosen the lock nut (C). Then rotate the adjusting sleeve and the inner threaded rods to such a length that the desired height of the armrest is achieved. Mount in reverse order.

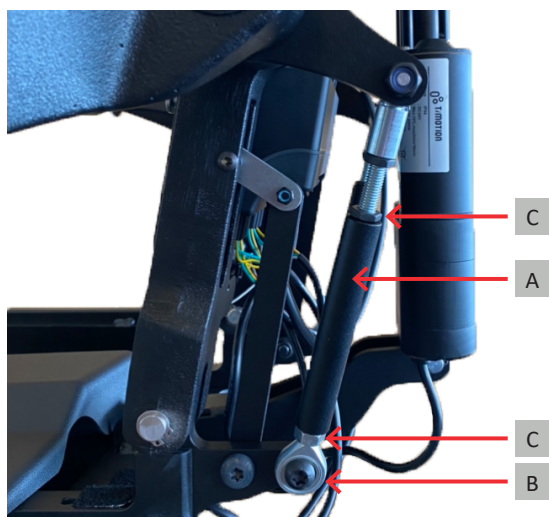

Height adjustment armrest.

Adjust the angle of the armrest cushion

To adjust the angle of the armrest cushion, loosen the screw (A), then loosen the screw (B) and the angle can be adjusted. Tighten screw (B) and then screw (A) again.

Always perform a load test to check that the armrest is properly attached.

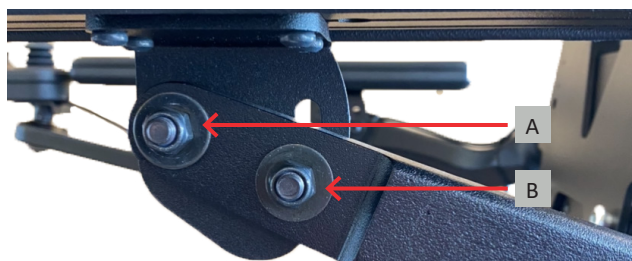

Exterior (locknut).

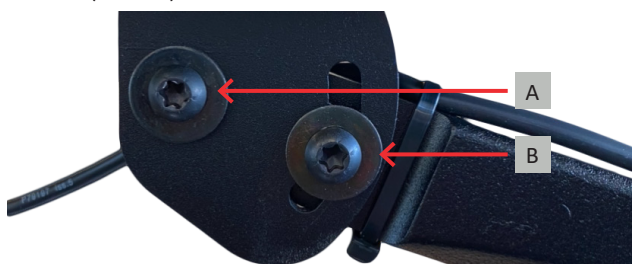

Inside (5 mm Allen key).

Upholstered lateral support (optional)

The optional upholstered lateral support offer support on the upper body. The supports are adjustable in height, width, depth and angle. The supports can also be flipped sideways for transfer into or out of the wheelchair. During this sideways flipping the adjustments stay intact. The soft rounded pads ensure optimal support and great comfort.

Our accessories for the LS chair are constantly under development.



Upholstered lateral supports.

Lateral support settings

The optional lateral support can be adjusted step less in height, depth, width and angle.

Set the height of the lateral support.

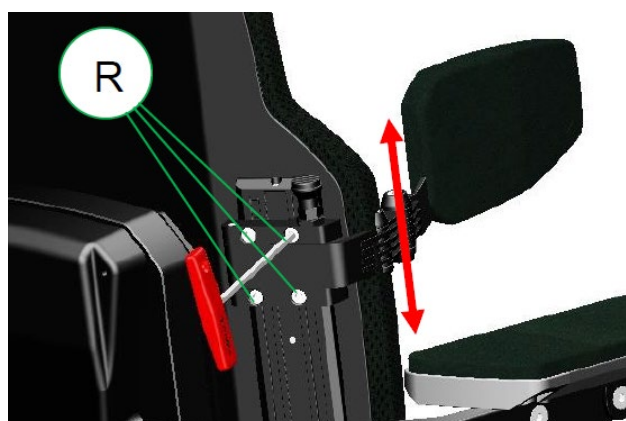

Step 1: Loosen up the bolts (R) using a 5mm Hex key.

Step 2: Move the lateral support in to the required height.

Step 3: Tighten the bolts.

Adjust the depth width and angle of the lateral support.

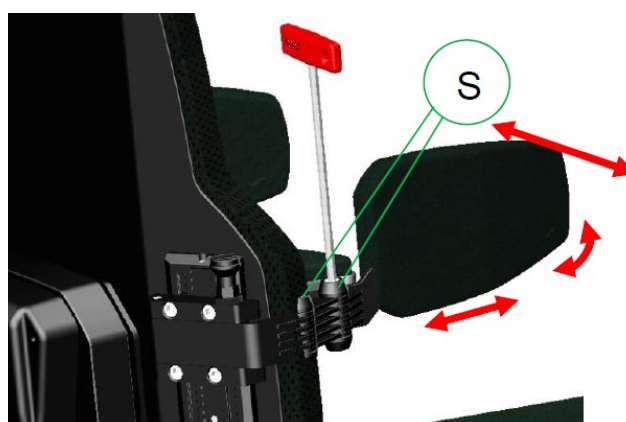

Step 1: Loosen the bolts (S) of the friction joints.

Step 2: Move the pad into the required angle, depth and width.

Step 3: Tighten the bolts to fixate the setting.

Seat belt (optional)

For positioning, several types of belts are available.



Seat belt (installation)

The optionally positioning belt can be adjusted in length and anchoring point. To change the setting simply follow the next steps:

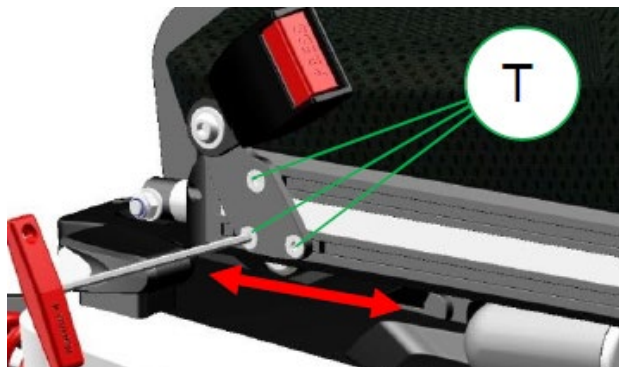

Step 1: Loosen the bolts (T) using a 4mm Hex Key.

Step 2: Move the bracket in the required position.

Step 3: Tighten the bolts.

Caution: Make sure the brackets are tighten properly to avoid sliding of the seat belt along the seat rail. A sliding seat belt might result in poor seating position of the user.

WARNING:

Positioning belt shall not be used as a safety belt in a moving vehicle.

Getting in and out

Bring your current seat as close as possible to the side of the LS. Make sure that the controller is turned off to prevent uncontrolled rolling. Fold up the armrest and footplate. Now slip sideways onto the seat of the LS, making sure that you are as far back as possible in the seat. Now fold down the footrest and the armrest again.



5. Technical specifications

Specification according to ISO 7176-15:1996

Maximum occupant mass: 136 kg

Mass of the test dummy according to ISO 7176-11:2012: 136 kg

| | | |
|---|-------------|--------------|
| Overall length (with legrest) | min. 970 mm | max. 1495 mm |
| Overall width | min. 630 mm | max. 734 mm |
| Folded length | 970 mm | |
| Folded width | min. 630 mm | max. 734 mm |
| Folded height | 855 mm | |
| Total mass | 174 kg | |
| Mass of the heaviest part (battery) | 21 kg | |
| Static stability downhill | 9° | |
| Static stability uphill | 9° | |
| Static stability sideways | 9° | |
| Teoretical distance range ¹ | 32 km | |
| Dynamic stability uphill | 6° | |
| Obstacle climbing | 50 mm | |
| Maximum speed forward | 9.9 km/h | |
| Minimum braking distance from maximum speed | 1950 mm | |
| Seat plane angle ³ | min. 0° | max. 45° |
| Effective seat depth ² | min. 380 mm | max. 580 mm |
| Effective seat width | min. 340 mm | max. 535 mm |
| Seat surface height at front edge | min. 340 mm | max. 600 mm |
| Backrest angle ³ | min. 90° | max. 140° |
| Backrest height | min. 500 mm | max. 680 mm |
| Footrest to seat distance | min. 370 mm | max. 680 mm |
| Leg to seat surface angle ³ | min. 99° | max. 174° |
| Armrest to seat distance | min. 275 mm | max. 415 mm |
| Front location of armrest structure | | |
| Horizontal location of axle | | |
| Minimum turning radius | 770 mm | |

¹ Use in steep conditions or rough ground etc. will have negativ impactk on the distance.

² At seat depth 380 mm to 430 mm, brackets for back mounting must be replaced.

³ Total range of motion for seat functions depend on seat unit chosen.

The wheelchair conforms to the following standards:

- requirements and test methods for static, impact and fatigue strengths (ISO 7176-8).
- power and control systems for electric wheelchairs requirements and test methods (ISO 7176-14).
- climatic test in accordance with ISO 7176-9.

Further Specifications

| | | |
|------------------------|------------------------------------|-------------|
| Headrest: | 0.8 kg | |
| Uneven ground: | 30 mm | |
| Ground clearance: | 70 mm (60 mm with clamp down unit) | |
| Steering range: | 1250 mm | |
| Turning area: | 1150 mm | |
| Overall height: | 1145 mm | |
| Seat width: | min. 340 mm | max. 535 mm |
| Length of the armrest: | min. 320 mm | max. 445 mm |

Operating forces

| | | |
|--|---------|--|
| Joystick: | ca. 1 N | |
| Button | ca. 1 N | |
| Coupling and decoupling of the drives: | 60 N | |

Tires

| | | |
|-----------------|----------|--|
| Tire pressure: | 345 kPa | |
| Rear tires: | 195 Ø mm | |
| Tires in front: | 350 Ø mm | |

Electrical

| | | |
|------------|-------------------------------------|--|
| Control: | PG dt R-net | |
| Batteries: | HZY-EV 12-60, 12V 60Ah | |
| Charger: | EC Buddy 10A XLR, type no: ECB-1001 | |

Environmental conditions

| | | |
|--------------|---|--|
| Temperature: | Avoid strong cold, heavy rain, and heavy snow | |
| Humidity: | 60% ± 20 % | |

Storage conditions

| | | |
|--------------|---|--|
| Temperature: | -25°C to 70°C | |
| Humidity: | 60% ± 20 % | |
| Batteries: | Should not be stored at temperatures below +5°C to maintain optimal durability and capacity | |

Materials

| | | |
|-------------------|--|--|
| Frame: | Steel powder-coated, corrosion-protected | |
| Attachment parts: | Steel / aluminum powder-coated anodised | |
| Seat cushion: | Flame retardant according to EN 1021-1 / 2 | |
| Back cushion: | Flame retardant according to EN 1021-1 / 2 | |
| Armrest cushion: | Flame retardant according to EN 1021-1 / 2 | |
| Headrest | Flame retardant according to EN 1021-1 / 2 | |

Batteries

The wheelchair is equipped with maintenance-free gel batteries.

If the wheelchair is not used for a long time, the charger should be connected every 6-8 weeks.

A complete discharge of the batteries should be avoided. Charging should be done in a ventilated room, Avoid open fire while charging. During the charging process, the wheelchair can not be used.

Attention: The replacement is only carried out by authorized professionals. The battery is located under the seat. The seat must be raised until it stops by itself.

Attention: Be aware that leaks or defective batteries are harmful to your health.



Type: HZY-EV 12-60.

Battery charger

| | |
|------------------------------|---|
| EC-Buddy (Swede Electronics) | 10A XLR, Type no: ECB-1001 |
| Dimension | 205 x179 x 90 mm |
| Charge current (wave-free) | Max. 10A |
| Mass | 1.3 kg |
| AC power | 230V 50Hz |
| Safety class | Type B |
| Insulation class | II (double insulated). This means that the charger can be connected to a standard socket without grounding. |
| Density class | IPX4 |

Charging

Important: EC-buddy is capable of charging batteries up to maximum battery size to 80% in less than 8 hours. The charger can be used for both GEL- and AGM batteries.

Important: The charger should only be used to charge batteries installed in wheelchairs.



10 Amp 24 V.

WARNING:

- Batteries emit explosive gases during charging. Avoid flames and sparks.
- The charger is intended only for GEL- and AGM batteries with 12 cells (24V).
- The charger is equipped with overheating protection, but can become hot during charging.
- Charging must be done in a well ventilated place.
- If one of the connectors becomes hot during operation, this can be an indication that the connector is worn or damaged. In such cases both the male and female connectors should be replaced.
- Cables and connectors must be changed only by the manufacturer or by an authorised service workshop.

Care and maintenance

- Each time you use the charger, make sure that the cables and connectors are not damaged or worn. If this is the case, the cable/connector must be replaced immediately by a manufacturer or an authorized service center.
- For the best results, economy and life of the charger, battery and driving distance per. charging, the following advice should be followed:
 - The charger, connectors and battery must be kept clean.
 - Switch off the wheelchair when not in use.
 - Charge the battery daily and as soon as possible after it is empty.
 - Use the charger to recharge the battery if the wheelchairs are stored for an extended period.
- The charger can be cleaned using a slightly damp cloth.

Attention: *The charger must only be used with wheelchairs whose power supply is designed for current loads that are at least equal to the rated charging current of the charger.*

The charging cable of the wheelchair must be dimensioned with a sufficiently dimensioned fuse.

Attention: *Non-rechargeable batteries must not be connected to the charger!*

The energy transfer from the mains to the battery takes place via a patented power circuit. The charging process is controlled by a microcomputer and adjusted automatically to the battery charge level. This optimizes the life of the battery. When the battery is fully charged, it will switch to trickle charge. An overcharge of the battery can not occur.

The charging time is as short as possible.

The “CHARGING”, “COMPLETED” and “ERROR” lamps on the front of the charger indicate the charging status.

Service information

NHD AS performs service on the LS. Request must be made directly to us (see item Manufacturer). Main components replaced by normal wear and tear are:

- Tire.
- Battery.
- Seat System.

A Service Manual or User’s Manual is available if necessary. Please contact us.

6. Examination of the wheelchair

Checking the brakes

Before each use you should check the brakes once. Drive carefully, then let go of the joystick, now the wheelchair must come to a standstill immediately. The click of the brakes should be audible. If the braking behavior deviates or shows unfamiliar behavior, please contact your dealer immediately.

Checking the tires



Drive wheel (front).

Swivel wheel (rear).

Please check the tire pressure regularly. Different air pressure in the tires affects the driving behavior unfavorably and leads to unwanted changes in direction. Too low tire pressure greatly increases the power consumption. The valves can be connected to common air pumps for car tires. Unscrew the plastic caps, attach the connector of the pneumatic tool to the valve, and fill the tire until the prescribed air pressure (drive wheel 345kPa, swivel wheel 345 kPa) is reached. Tires without hose (compact tires) do not have air filling.

If the tires are damaged, the hoses can be repaired or replaced, please contact the authorized dealer.

7. Cleaning and disinfecting

Cleaning

Make sure that the wheelchair is switched off before cleaning. Dirt must be removed immediately after use. Frame parts and panels can be cleaned with a damp cloth. For solid dirt, you can use a mild household detergent.

Be sure to thoroughly clean all surfaces of the wheelchair. Detergent residues can then be removed with a damp cloth.

Do not use abrasives, caustic substances, acids or bleach. Detergents based on chlorine, acetone or benzene must not be used. Do not use high pressure or steam cleaners. Electronic components and cables must not come into contact with water.

Disinfection

The wheelchair is suitable for cleaning with common household disinfectants. Spray or moisten the wheelchair evenly with the disinfectant. Then wipe all surfaces with a clean cloth.

Attention: Pay attention to the concentration and exposure times of the disinfectant manufacturer. The disinfectant should not be rinsed off but wiped with a cloth and then air dried. Afterwards, the wheelchair must be checked for cleanliness and possible damage.

Re-use of the wheelchair

The wheelchair is suitable for re-use. When passing on, care must be taken that the wheelchair is serviced by the specialized trade and is treated hygienically (see section on cleaning and disinfection).

8. Maintenance

Replacing the batteries

Replacement is only carried out by authorized personnel. The LS has 2 batteries located under the seat. Battery replacement is described in the Service Manual.



Type: Haze HZY-EV12-60
batterier.

Art. no.: KP-NHD10200.

Attention: Please note that leaking or defective batteries can be harmful to your health.

The power supply of the wheelchair

At the back of the chair you will find the chair's power supply switch. When the fuse is in, the power is on. When the fuse is out, so the white ring can be seen, the power is off.



In= Power on.

Out= Power off.

Repair/maintenance plan

Have repairs carried out by trained specialist personnel only. To prevent damage, we recommend to follow a maintenance plan.

Before every ride:

Please check as described in Chapter "Checking the brakes", to see if they are working properly. Make a visual inspection, damaged or missing frame parts should be repaired or replaced immediately by authorized service personnel.

Monthly:

Check the air pressure of the tires, different tire pressure leads to unintentional change of direction, too low air pressure increases the power consumption considerably.

Quarterly:

Check fasteners such as nuts and bolts for tightness. Test whether the tires still have sufficient tread depth (min.1 mm). Check all cables and connectors and have them fastened or replaced by a specialist dealer if necessary.

Yearly:

Have your wheelchair checked and repaired by the dealer if necessary.

The expected life of your wheelchair is 8 years. However, this depends on the frequency of use, care and the environment in which your wheelchair is used and stored.

⚠ WARNING:

Maintenance work or technical repairs may only be carried out by authorized specialist dealers.

9. Transport

Guideline for transportation in a vehicle



Approved label.



Placed on the side of the battery case.

The LS complies with the requirements specified in ISO 7176-19:2022.

It has been designed and tested according to the ISO 7176-19:2022, for transportation in a occupied position, forward facing in a vehicle.

The wheelchair is designed to use a 4-point heavy duty webbing restraint. For this matter the wheelchair has two brackets on the front end and two brackets on each rear side of the chassis. The brackets are indicated with a sticker. These anchoring points shall be used to connect the tie-down belt to.



The brackets are indicated with this sticker.



The chair has 4 brackets.

4 point Tie-down belts

For the tie down belt we advice to use a “Dahl heavy duty” tie-down belt, model 503172. The angle of the straps should be around 45° to the horizontal plane. This is in order to have maximum effect in vertical and horizontal direction.



Tie down straps under 45° angle.

The straps have to be connected to the vehicle at suitable anchor points. Make sure that the tire pressure is at the recommended level so the straps can have maximum effect. Make sure the straps are tightened to maintain optimal security.

⚠ WARNING:

Poor fixations of the wheelchair in a vehicle might cause damage to the vehicle itself, the wheelchair or the passengers inside the vehicle while driving. Not using a car safety belt while sitting in a wheelchair might lead to serious injuries in case of an accident.

Note: *The access to, and maneuverability in, motor vehicles can be significantly affected by wheelchair size and turning radius.*

Smaller wheelchairs and/or wheelchairs with a shorter turning radius will generally provide greater ease of vehicle access and maneuverability to a forward-facing position in the vehicle. Also the internal size of the vehicle will have a great influence of the maneuverability into and out of the vehicle. Make sure that there are no loose objects inside the vehicle, which can lead to a more complicated positioning inside the vehicle.

Although the wheelchair is designed and tested according to the ISO 7176-19:2022 requirements, we also advice: wheelchair users should transfer to the vehicle seat and use the vehicle-manufacturer-installed restraint systems whenever it is feasible, and the unoccupied wheelchair should be stored in a cargo area or secured in the vehicle during travel.

For more information about tie down kits for vehicles and/or further information about tie-down belt and occupant 3-point safety belt, please visit the website of Dahl engineering at; WTORS.com.

⚠ WARNING:

Any wheelchair anchored occupant restraint i.e. 3-point belt, harness or postural supports (lap straps, lap belts) should not be used or relied on for occupant restraint in a moving vehicle, regardless if labeled ISO 7176-19, ISO 10542-1, SAE J2249 or any other. Use a vehicle anchored and certified occupant restraint system instead.

General occupant restraint Instructions.

DANGER!

- Use a 3-point occupant restraint system to secure the occupant.
- Both pelvic and upper torso restraint belts must be used to restrain the occupant to reduce the possibility of head and chest impacts with the vehicle components.
- Any wheelchair anchored occupant restraint i.e. 3-point belt, harness or postural supports (lap straps, lap belts) should not be used or relied on for occupant restraint in a moving vehicle, regardless if labeled ISO 7176-19, ISO 10542-1, SAE J2249 or any other. Use a vehicle anchored and certified occupant restraint system instead.
- Use a suitable positioned headrest when being transported in a wheelchair.
- Occupant restraints should make full contact with the shoulder, chest and pelvis and pelvic belts should be positioned low on the pelvis near the thigh-abdominal junction (meeting the requirements specified in ISO 7176-19:2022).
- The upper torso restraint belt must fit over the midpoint of shoulder and across the chest as illustrated
- Restraint belts must be adjusted as tightly as possible consistent with user comfort.
- Restraint belt webbing must not be twisted when in use.
- Care should be taken when applying the occupant restraint to position the seatbelt buckle so that the release button will not be contacted by wheelchair components while driving or during a crash.
- Belt restraints must not be held away from the body by wheelchair components such as armrests or wheels.

Safety belt

If the user is transported in their wheelchair, it is necessary to use a car safety belt to secure the wheelchair user.

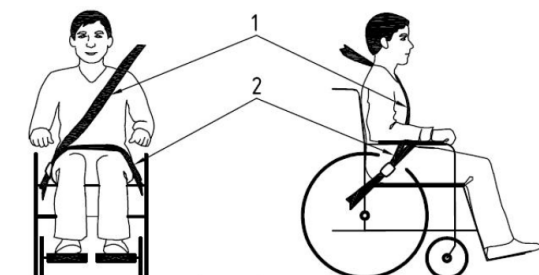

Positioning of the car safety belts for wheelchair users.

The wheelchair has been crash tested using tie down belts, and a 3-point occupant safety belt. We advise you to use a Dahl 3-point occupant safety belt model 500984 system or a system that is equally specified. It is very important to use the safety belt in the right angles according to the wheelchair user.

Tie-down strap angles

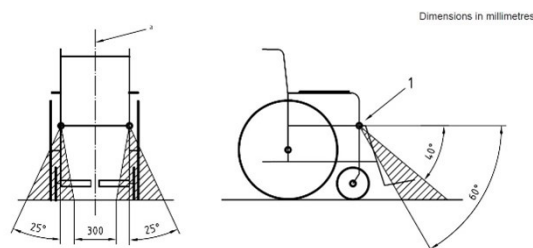

Figure 1: Preferred angles for front tie-down straps.

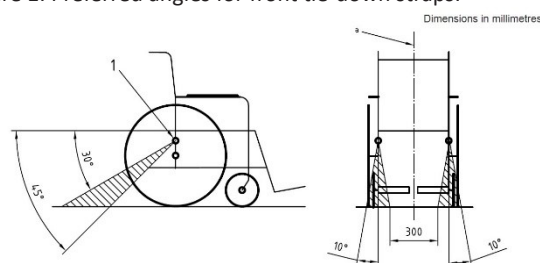

Figure 2: Preferred angles for rear tie-down straps.

Positioning the occupant restraint when using it with a 4 point strap tie-down system

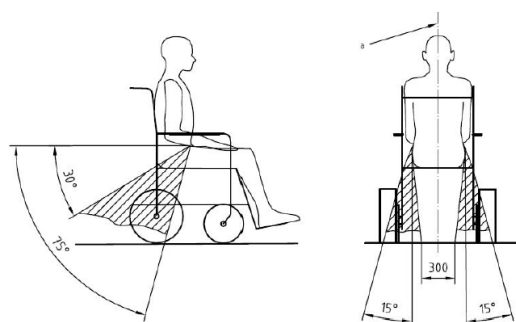

Figure 3: Preferred and optional angles for location of the lap belt.

The angle for the pelvis part (2) of the safety belt must be in angle of 30- 75° with the horizontal plane (see figure 3). Also the side angle should stay between the vertical plane to maximum of 15° angle with the vertical plane (see figure 3).

The shoulder part (1) of the safety belt should be positioned according to the figure 4.

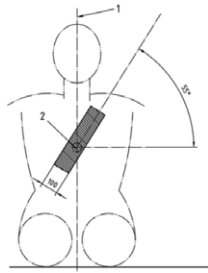

Figure 4: Upper torso safety belt positioning.

Positioning the occupant restraint when using it with the Dahl Docking systems only

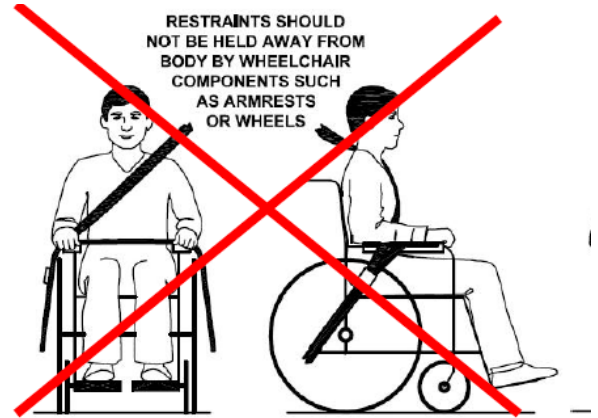
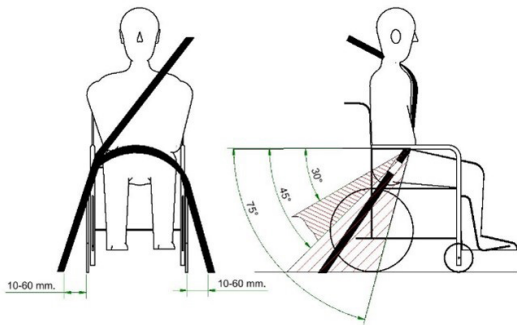

Figure 3: Picture of improper belt fit.

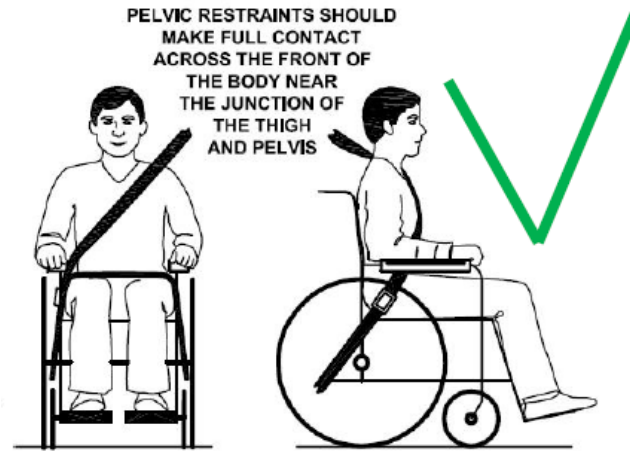

Figure 4: Picture of proper belt fit.

Note: Please follow these points for optimal personal safety for the wheelchair user:

1. The pelvic belt should be worn low across the front of the pelvis, so that the angle of the pelvic belt is within the preferred zone of 30° to 75° to the horizontal, as shown in figure 1.
2. A steeper (greater) angle within the preferred zone (30-75°) is desirable.
3. Belt restraints should not be held away from the body by wheelchair components or parts, such as the wheelchair armrests or wheels, see figure 3.
4. Upper torso safety belt should fit over the shoulder and across the chest, as illustrated in figure 2.
5. Belt restraints should be adjusted as tightly as possible, consistent with user comfort.
6. Belt webbing should not be twisted when in use.

Note: When using wheelchair with Dahl Docking systems, the floor anchoring point for the occupant restraint system, shall be located 10 - 60 mm outside the wheels on each side.

Note: Please, make sure the following conditions are fulfilled to obtain a safe transportation:

1. Whenever possible the occupied wheelchair shall be located in a forward-facing configuration and secured by the tie downs in accordance with the WTORS (wheelchair tie down and occupant restraint system) manufacturer's instructions.
2. This wheelchair is suitable for use in vehicles and has met the performance requirements for travelling forwards-facing in frontal impact conditions. Its use in other configurations within a vehicle has not been tested.
3. The wheelchair has been dynamically tested in a forward-facing orientation with the ATD (anthropomorphic test device) restrained by both pelvic and upper torso belts.
4. Both pelvic and upper torso belts should be used to reduce the possibility of head and chest impacts with vehicle components.
5. When possible, other auxiliary wheelchair equipment should be either secured to the wheelchair or removed from the wheelchair and secured in the vehicle during transit, so that it does not break free and cause injury to vehicle occupants in the event of a collision.
6. Any wheelchair anchored occupant restraint i.e. 3-point belt, harness or postural supports (lap straps, lap belts) should not be used or relied on for occupant restraint in a moving vehicle, regardless if labeled ISO 7176-19, ISO 10542-1, SAE J2249 or any other. Use a vehicle anchored and certified occupant restraint system instead.
7. The wheelchair should be inspected by a manufacturer's representative before reuse following involvement in any type of vehicle impact.

Note: Alterations or substitutions should not be made to the wheelchair securement points or to structural and frame parts or components without consulting the manufacturer.

Only use "gelled electrolyte" batteries on powered wheelchairs when used in a car.

⚠ WARNING:

Pay extra attention when placing the seat belt lock, so that the release button does not come into contact with parts of the wheelchair or other parts, and is unlocked in the event of a heavy braking or a collision.

Backrest, legrest and headrest settings during transportation.

During transportation in a occupied position, the backrest of the wheelchair needs to be set into an upright position. The legrest should be in a knee angle close to 90 degrees. The headrest needs to be adjusted well so it will catch the head of the wheelchair user during the rebound of an impact, this to reduce the risk of a whiplash.



Note: The wheelchair is suitable for land transport and air transport. LS batteries comply with IATA Dangerous Goods Regulations 806, special provision A67.

Note: The wheelchair cannot be disassembled for transport.

Note: Recommended position of the backrest, legrest and headrest, see picture above.

If you want to transport the wheelchair empty, you can easily remove the headrest to save space. Loosen the hand screw and then pull the headrest out of the holder. To replace it, reverse the procedure and tighten the lever again.

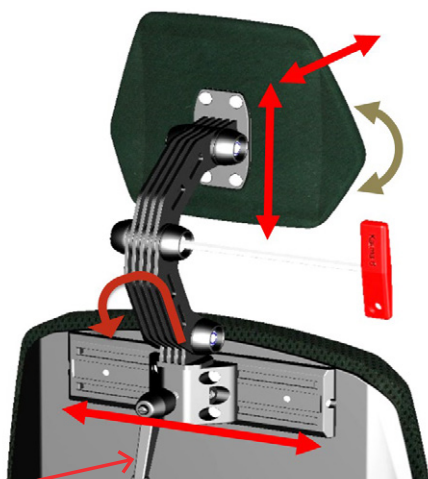

Handle to loosen and tighten the headrest.

Transportation using Dahl Docking stations

LS has been crash tested and is compatible with Dahl docking station mk 2 and VarioDock tie down system according to ISO 7176-19:2022 and ISO 10542-1:2012, where the wheelchair is facing forward in driving direction (driving direction like the driver seat).



The locking of the wheelchair into the Dahl Docking station make it much easier to lock down the wheelchair for occupied transportation. It can be used also for wheelchair users who want to drive the car by themselves.

The system is self locking and can be release by pushing a button. The locking device will open up for a certain time to make the un docking possible.

WARNING:

The Dahl Docking station is only allowed to build in to a vehicle by trained and authorized staff of a registered car adaptation company. For ordering the Dahl Docking and its accessories, please contact Dahl Engineering in Denmark for further details. You can find Dahl at; WTORS.com.

The Dahl Docking station

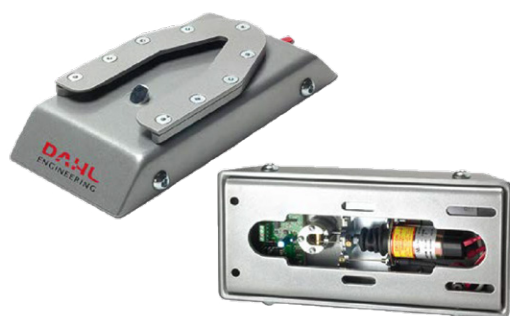

Dahl Docking station.



Dahl docking station mounted on the floor.



Docking station and locking plate on chassis.

Locking procedure

Drive the wheelchair slowly into the vehicle and make sure you centre your wheelchair in the middle of the docking module. If well positioned the locking system will also guide the wheelchair into the docking station. Continue driving slowly until you feel the wheelchair reach the end position in the docking station. At the same time you will hear a clicking sound. The wheelchair is now locked in to the docking station. The light on the control panel will light up the LED showing the wheelchair is locked in correctly. Now switch the wheelchair off.

⚠ WARNING:

If the wheelchair is not centered correctly, it might not be possible to lock in to the docking station. In that case, retry by driving a bit backwards and re-center the wheelchair. Try once more until you hear the clicking sound and you see the locked sign LED on.

After the wheelchair is locked in, put the car safety belt on according to the instruction "Safety belt".

Do not forget to put the car safety belts on before driving in the vehicle. This in order to avoid dangerous situations and personal or wheelchair damage.

Unlocking procedure

To unlock the wheelchair, first open up the car safety belt. Then switch on the wheelchair and switch to drive mode. Now push the release button of the Dahl Docking station. You will hear a firm click. The locking bolt is now retracted and the wheelchair can drive in reverse direction out of the Docking station.

Note: *After pushing the release button of the Dahl Docking station, the locking bolt is retracted for a certain period of time. After that time, the bolt will lift up again and lock the Docking station. Make sure you drive your wheelchair out of the Docking station in this time window of the unlocked position. If not, you have to push the release button one more time.*

Dahl Engineering offer two docking systems, the Mk 2 art. no 501750 and the power height adjustable called Dahl VarioDock (no 503600). Please also refer to Dahl Engineering instructions for installation, use and maintenance for the system used.

Manually unlocking in case of electric failure or accident:

The Dahl Docking station can be unlocked manually in case of an emergency or if the electric unlocking is failing.



To unlock the docking station manually, the red lever needs to be pulled to the right. This retracts the locking bolt manually so the wheelchair can be released out of the docking station.

⚠ WARNING:

In case of a failure of the docking station, contact your local car adaptation company who has built the device into your vehicle. Only authorized and trained staff is allowed to work on the docking device.

The mounting of the Dahl Docking station into your vehicle shall only be executed by a authorized car adaptation company. They will get the right support and information from Dahl Engineering on how to mount the docking station into the designated vehicle.

If the described manual release procedures fails, an emergency release tool made from red plastic comes with each docking station.



1. Move wheelchair forward to remove the pressure on the lock pin
2. Place the emergency release tool in the gap between the locking plate and the docking station.
3. Push the release tool and wheelchair forward until the locking pin has been forced down - after which the wheelchair can reverse out of the docking station.



Dahl Docking Station Mk 2 kit. Art. no. 501750

Dahl VarioDock is a power-height adjustable wheelchair Docking station, which facilitates securing wheelchairs with different ground clearances and vehicle passenger seats with integrated 3 point belt, but it is also the only system to meet standard ISO 10542-1, ISO 7176-19:2022



Dahl Vario Dock kit. Art. no. 503600

⚠ WARNING:

Dahl docking station is only permitted to be fitted to wheelchairs by trained and authorized personnel of a registered car adaptation company or the wheelchair manufacturer's service partners. To order the Dahl Docking System with accessories, please contact Dahl Engineering in Denmark for further details. You can find more information about Dahl Engineering at; WTORS.com.

Brackets for attaching the wheelchair

For transport the wheelchair must be attached to the anchor points provided for this purpose. See picture below. The control must be OFF and the brake release handles must be in the "LOCK" position.

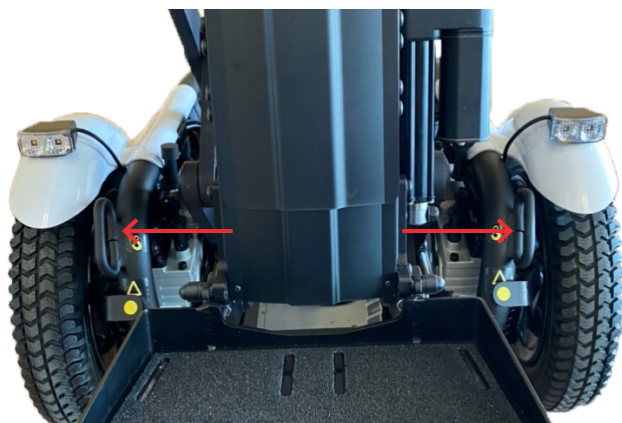

Brackets for attaching the wheelchair.

Mounting of the Dahl docking adapter on the wheelchair

The LS chassis is equipped with a Dahl docking plate underneath the battery box frame of the chassis.

For detailed information about the Dahl Docking system please visit the homepage; WTORS.com

To fit the Dahl docking plate, Dahl has created a special kit for LS which includes the special Dahl nut plates and spacers for battery box of LS to level the batteries. This kit is available under Dahl part no: 503341.

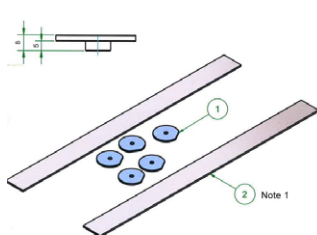

Description of the mounting:

1. Remove the batteries from the chassis and put the 5 special Dahl nut plates in to the dedicated mounting holes from the inside of the battery box.
2. Two plastic spacers are to be placed in every battery box on the floor. Best is to fix them with some double sided tape.
3. Now take the Dahl spacer (Dahl part no: 500673 docking plate, Dahl part no: 500561 and 5 special Dahl high grade steel (14.9) Torx bolts Dahl part no: 502800) to mount the Dahl docking plate on to the LS chassis.
4. After cutting the bolts to the right length, Loctite 222 needs to be added on to the thread to secure the bolts.
5. The five Torx bolts must be tightened with a torque wrench to the preset torque of 16 - 18 Nm.
6. Place the batteries back into the chassis and connect them to the electronics.

Note: The special Dahl high grade Torx bolts (Dahl part no: 502800) only come in one length which often is too long. They need to be cut into the right length by the authorized engineer to fit the locking plate properly without damaging the batteries.

WARNING:

Do not use any other bolts than those supplied by Dahl (part no. 502800) which are quality 14,9 torx key size 22. Standard countersunk M8 bolts will not be strong enough in the event of a collision.

Spacer #500673

Locking plate #500561

Bolt #502800

LS / Dahl mounting kit.

Note: Spacers (503346) are not used if the wheel chair have premounted rails.

10. Storage

If the wheelchair should be stored, please proceed as follows:

- Turn off the wheelchair, disconnect the battery power connections, or remove them completely. Note that the battery should not discharge completely, if necessary contact an authorized dealer.
- Batteries should not be stored at temperatures below +5°C to maintain optimal durability and capacity.
- Only the headrest can be removed for storage.
- Do not store the wheelchair in rooms with high condensation, such as laundry rooms or damp basements.
- Before restarting, carefully check the wheelchair for any visible damage. Connect the battery, check if the tires have the required air pressure. Check all functions. Test whether the brakes fully perform their function.
- If you detect a malfunction, contact the authorized dealer.
- If you want to change the basic settings, have them made by an authorized dealer.

11. Disposal

If the electric wheelchair is to be disposed of, please contact your dealer. If you want to dispose of the wheelchair yourself, contact the responsible waste disposal companies and act according to the relevant regulations. Part's that can be recycled are marked with recycle mark. You have to follow the local legal regulations for recycling.

12. Warranty

Warranty period table LS

| Description | Warranty period | Examples |
|--|--|--|
| Frame | Within 5 years | Production defects on frame |
| Parts | Within 2 years | Production and / or material defects |
| Drive system* | Within 2 years | Transaxle, brackets, motor and brak |
| Electronics* | Within 2 years | Powermoduler, wiring and electronics components |
| After sales service parts | New: Within 1 year, after invoice. Repaired: Within 1 years after invoice | Brakes |
| Consumable parts | Within 1 year, after invoice | Brushes for drive motor, batteries, armrests, covers, tires etc. |
| Consumable parts Options/ Accessories | Within 2 år | Handbag holder, basket etc. Delivered with the initial product |

* also in case of after sales service part delivery

Attention: Normal wear and tear or damage because of mishandling or incorrect use does not provide a basis for complaint.

13. Pre-Sale Information



LS

THE LOWEST
SEAT HEIGHT ON
THE MARKET

Updated June 2022



LS

- **LOWEST SEAT HEIGHT** provides trouble-free entry and positioning in the car – on driver's side as well as the passenger side in the vehicle
- **LOWEST CENTER OF GRAVITY** provides stability and driving comfort when driving outdoors
- **LOWEST POSSIBLE SEAT HEIGHT INDOORS** in order to fit under regular tables and to reach the floor

LS IS IDEAL FOR POSITIONING ON DRIVER AND PASSENGER SIDE IN VEHICLE

LS PROVIDES THE OPPORTUNITY TO DRIVE THE CHAIR INTO LOWER CAR MODELS – IN ORDER TO MAKE IT EASIER TO DRIVE INTO PARKINGHOUSES, AMONG OTHER THINGS

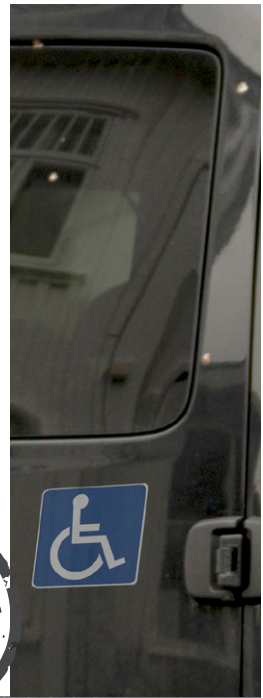

| SPECIFICATIONS LS | | | |
|-------------------------------|--------------------|---|-------------------|
| Seat height (without cushion) | from 340 - 600 mm | Overall width | from 630 - 734 mm |
| Seat depth | from 420 - 545 mm* | Total mass | 174 kg |
| Seat width | from 340 - 535 mm* | Maximum occupant mass | 136 kg |
| Seat angle | 0 - 45° | Front tires | 350 mm |
| Backrest angle | 90 - 140° | Rear tires | 195 mm |
| Backrest height | 500 - 680 mm* | Can be delivered complete with all electric seat functions. | |
| | | *) Other sizes and measurements upon request. | |



STABLE SEAT LIFT Safe and stable seat.



FOLD-UP ARMRESTS and control box that can be swiveled back provide easier access and positioning.



DAHL DOCKING and strap fasteners for attachment to vehicles.



THE IMPORTANT DETAILS



BACK AND SEAT CUSHIONS

SEATING SYSTEM WITH HIGH COMFORT AND ADAPTABILITY FOR DIFFERENT TYPES OF SEATING PROBLEMS. BACK AND SEAT CUSHIONS CAN BE ADAPTED TO YOUR NEEDS



STANDARD BACK CUSHIONS are available in two different variants with sizes for small and large users.



SEAT CUSHIONS are available in several variant in different widths and depths.







General information

| | | | |
|---|--|---------------------------------|---|
| Visually impaired | Contact producer/supplier for electronic information. | Operator control adjustment is: | speed / velocity seat functions mode driving mode light on/off indicators |
| Intended use | Class B electric wheelchair is designed for indoor and outdoor use by persons with impaired mobility. | Storage condition | If the chair should be stored for more than 2 months - do it in a dry room with not less than 10 °C. Remember to charge the chair every 6-8 weeks. Only the headrest can be removed for storage. |
| Requirements for use | Adequate cognitive and Physical ability for safely operations of the wheelchair under different conditions | Maintenance instructions | Repairs shall be carried out by trained specialist personnel only. To prevent damage, we recommend following maintenance plan in User Manual. The replacement of parts shall only be carried out by authorized specialist personnel. |
| General demand for surface | Avoid slopes over 6° and driving on slippery surface. | Cleaning instructions | Make sure that the wheelchair is switched off before cleaning. Dirt must be removed immediately after use. Frame parts and panels can be cleaned with a damp cloth. For solid dirt, you can use a mild household detergent. Detergent residues can then be removed with a damp cloth. Do not use abrasives, caustic substances, acids or bleach. Detergents based on chlorine, acetone or benzene must not be used. Do not use high pressure or steam cleaners. Electronic components and cables must not come into contact with water. Wipe off moisture with a dry cloth. |
| Documentation | EN 12184:2014 with relevant sub standards | Disinfection instructions | The wheelchair is suitable for spray and wipe disinfection with common household disinfectants. All surfaces should be wiped with a clean cloth moistened with disinfectant. Observe the concentration and exposure times of the disinfectant manufacturer. |
| Wheels | LS is equipped with air filled wheels. | Footrest to seat distance | min. 370 mm maks. 680 mm |
| Adaptions | Make sure you have adjusted the wheelchair to your needs before driving. | Leg to seat surface angle | min. 99° maks. 174° |
| Transport | The unoccupied wheelchair is suitable for land transport and air transport. LS batteries fulfill IATA's dangerous goods regulations packing instructions 806, special provision A67. Only the headrest can be removed for transport. Main switch is used to put the chair in a powerless state. | Armrest to seat distance | min. 275 mm maks. 415 mm |
| Transport in vehicle | The wheelchair is tested after ISO 7176-19:2022 and approved for use in vehicle. | Minimum turning radius | 770 mm |
| Driving distance theoretical | 32 km under intended use. Use in steep conditions or rough ground etc. will have negative impact on the distance. | | |
| Height of curb to descend safely | 70 mm (60 mm with clamp down unit) | | |
| LS has a programmable controller | PG-dt-R-net. This can only be programmed by authorized service personnel. | | |
| Pivot width | 1250 mm | | |
| The intended operator | The intended operator is the occupant, but it can also be the assistant. | | |
| The standard options that are available for the wheelchair is: | different seating systems attendant control lateral support | | |
| Equipment designed by the manufacturer that can be removed without the use of tools | The headrest can be removed without tools. This is unfavorable when using the chairs. Favorable for transportation. | | |

14. Manufacturer

NHD AS
Gigstads vei 22
3511 Hønefoss
Norway
www.nhd.as
Mail: post@nhd.as
Phone: +47 993 16 100

If you have questions or any product feedback regarding the LS Power Wheelchair, please mail or phone. See information above. You find information about product safety or product recalls at www.nhd.as.

**NHD AS** 2021-01-01
Gigstads vei 22, 3511 Hønefoss, Norway
GTIN: 7090053360001
Type: LS
Modell: LS
SN: 210101-xxxxxx

  **MAX 136 Kg**  max. 6°
 See user manual or www.nhd.as



Manufacturer:

NHD AS

Gigstads vei 22

3511 Hønefoss

Norway

T: +47 993 16 100

E: post@nhd.as

www.nhd.as

See list of distributors at WWW.NHD.AS