

# DAHL VARIODOCK™

Maintenance Manual

Installation and User Guide



ENG

503749 · 03.2023

**DAHL**   
ENGINEERING

# For wheelchair and user facing forward in the vehicle

## IMPORTANT:

Please read these instructions in full before commencing installation. Users must also read the instructions in full before using the product. These instructions must be submitted to the user on delivery of the VarioDock and should be kept at an easily accessible location in the vehicle.

## Table of contents

|                                     |       |
|-------------------------------------|-------|
| Warnings                            | 3     |
| Declaration of conformity           | 4     |
| Product overview                    | 5     |
| Documentation at handover           | 6     |
| Maintenance interval                | 7-12  |
| User guide                          | 13-15 |
| Installation of Dahl VarioDock      | 16-19 |
| Tightening torque                   | 20-21 |
| Electrical connection               | 22-24 |
| Accessories                         | 25-26 |
| Using VarioDock to anchor car seats | 27    |
| Safety belts                        | 28-31 |
| Floor pockets                       | 32-33 |
| Spare parts                         | 34-35 |

The securing system for the wheelchair and safety belts for the user may be designated with the abbreviation WTORS (Wheelchair Tiedown & Occupant Restraint Systems) in these instructions.

## Warnings

1. In the event that the instructions and warnings in this guide are not followed, there is a risk of death or serious injury to the wheelchair user and the other passengers in the vehicle.
2. Please contact the wheelchair manufacturer regarding approved equipment and ground clearance to ensure compatibility with our Dahl Docking Systems.
3. Installation must be carried out by an experienced technician/fitter.
4. The docking station must be serviced and parts replaced with original Dahl parts according to the instructions of the service manual. Failure to comply with the instructions of the service manual may render the product partially or completely inoperative or cause damage to the product, which can result in serious or lethal injury to the user and/or other passengers of the vehicle in the event of fatal injury.
5. Never begin driving the vehicle whilst a wheelchair is being docked in the docking station or if the user's safety belt is not secured.
6. Never begin driving the vehicle if the warning tone sounds and/or the red warning lamp (LED) in the control panel flashes or lights up.
7. WTORS may only be used for forward-facing wheelchairs.
8. Contact Dahl Engineering or your dealer immediately if there is any doubt concerning the use of the product or if the product has faults or non-conformities.
9. Users in wheelchairs should never be transported in the vehicle if certified WTORS are not used.
10. The user should not be a passenger or driver of the vehicle if both lap belts and shoulder belts are not used. This is to reduce the risk of the user's head or chest hitting interior vehicle elements and other passengers.
11. The docking system, seat belts and components shall be subjected to a check and maintenance inspection at least once a year in accordance with maintenance interval and documentation.
12. The user should never try to repair, adjust or modify the WTORS components. Alterations or modifications to the system are strongly discouraged. Any alterations carried out without prior agreement with Dahl Engineering are entirely the responsibility of the fitter and/or the user.
13. It is forbidden to combine Dahl WTORS components with those of other manufacturers. Some belt fittings/components will be very obviously incompatible, while others may appear to engage correctly, but might not withstand crash loadings or perform satisfactorily.
14. Do not attach components to weak/non-solid components or materials.
15. The fitter is responsible for ensuring that the installed unit satisfies all statutory requirements. Contact local/national authorities if there is any doubt in this regard.
16. Incorrect installation of safety belts and the docking station can cause malfunctions which can result in death or serious injury to the user.
17. Belt webbing must be protected against contact with sharp edges and corners, contact with solvents, polishing agents, oil and caustic/corrosive fluids or materials (in particular battery acid). Damaged, worn, torn or contaminated belt webbing and components must be replaced. This should be checked daily.
18. An airbag should be deactivated if the user is situated less than 300 mm from the airbag, or as recommended by the vehicle manufacturer. An airbag should also be deactivated if retrofitted parts block or have an effect on its inflation/expansion. If it is necessary to deactivate or remove the airbag, it is imperative, before fitting the docking system, to check if the vehicle manufacturer can offer a safety belt which is approved to be fitted without an airbag.
19. A docking station which has been involved in a collision from which the vehicle has had to be towed away or where the airbag has been deployed, must be sent to DAHL Engineering for inspection and possible repair. Safety belts and components must be replaced without separating the components, because they may have suffered damage that is not visible to the naked eye.
20. Be sure to check national regulations with regard to minimum clear space requirements and access to emergency exists for seats and wheelchairs for the vehicle concerned.
21. It is essential, that wheelchair manufacturers' instructions, references and warnings are followed when installing and using Dahl Docking Systems. The EU medical device directive states that a CE-marked medical device which has been customized outside the manufacturer's specifications thereby becomes a customized medical device and that the CE-marking must be removed. Anyone who customizes a CE-marked medical device outside the manufacturer's specifications is responsible for quality, safety and performance of the device and becomes the responsible manufacturer of the customized device.  
Complying with the wheelchair manufacturer's user and installation guide when installing the Dahl Docking System will ensure that the wheelchair manufacturer's CE-marking will remain intact. Manufacturer manuals for all CE-marked wheelchairs can be downloaded from our website.

## Declaration of conformity

Dahl Engineering's objective is to provide products for wheelchair users which meet the strict EU M1 safety requirements for cars, when it is possible, and to the extent it is possible, with due consideration of the design and function of the aid and appliance concerned. We are therefore continuing our efforts to develop a range of tested and approved installation kits for different vehicles. These installation kits are tested according to EU regulation 2018/858, ECE R14 & R17, concerning seats and safety belt anchorages in vehicles.

The docking system (#503600) has been crash tested in frontal collisions at 48 km/h, 20g in connection with a surrogate wheelchair weighing 200 kg+ test dummies with a mass of 76,4 kg and 102 kg, where the lap belt was anchored to the floor of the vehicle (276,4 kg and 302 kg total weight).

**As manufacturer, we hereby declare that the docking system's country of origin is Denmark and that the docking system, and the wheelchairs listed on our website are successfully tested according to the following:**

- ISO 10542-1:2012 with ISO surrogate wheelchair
- ISO 7176-19:2008, with specific wheelchairs, see list of tested and approved wheelchairs on our website
- EU Regulation 2018/858, ECE R14 & R17 in many different vehicles, see product catalogue
- ECE R10 (Electromagnetic compatibility in vehicles)
- A seat base which fits the Docking Station has also been tested to meet ECE R14 and ECE R17



Claus Dahl Pedersen, CEO  
Dahl Engineering ApS

### Visit our homepage for more information

All successfully tested wheelchairs as well as wheelchair manufacturers user and installation instructions can be found on our homepage - under products - dahl docking systems: [www.wtors.com](http://www.wtors.com)



All tested and approved installation kits can be found in our product catalogue which can be downloaded from our homepage - under support: [www.wtors.com](http://www.wtors.com)



Please do not hesitate to enquire whether a wheelchair or an installation kit that has been tested in accordance with the above directives, is available for the vehicle concerned. In this case, separate installation instructions are available, which **must** be followed when installing the docking station.

## Product overview

Inspection of the components delivered:  
Start by checking if all of the components have been delivered correctly. Please contact us immediately if any parts are missing.

The contents of a standard kit with Dahl VarioDock, art. no. 503600, are shown on the next page. Safety belts for securing the user are not included in a standard kit and must be ordered separately!

Art.no. 503600

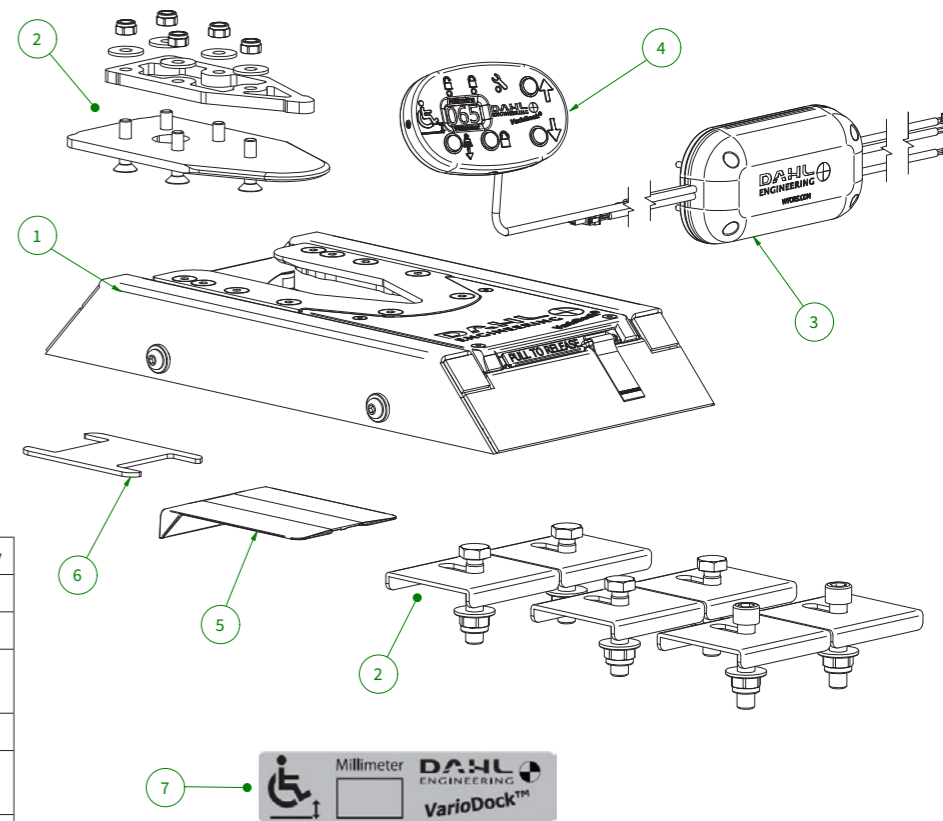

| Position | Name                            | Art. no. | Quantity |
|----------|---------------------------------|----------|----------|
| 1        | Dahl VarioDock™                 | 503441   | 1        |
| 2        | Installation kit                | 503699   | 1        |
| 3        | Complete control box with wires | 503700   | 1        |
| 4        | Control panel                   | 503553   | 1        |
| 5        | Emergency release tool          | 503161   | 1        |
| 6        | Installation tool               | 503610   | 1        |
| 7        | Sticker                         | 503653   | 1        |

## Documentation at handover to customer

Vehicle specifications: \_\_\_\_\_

Make & Model: \_\_\_\_\_

Vehicle Identification Number: \_\_\_\_\_

Year: \_\_\_\_\_

Information about the docking station: \_\_\_\_\_

\_\_\_\_\_

\_\_\_\_\_

Article Number: \_\_\_\_\_

Serial Number: \_\_\_\_\_

Production Date: \_\_\_\_\_

### VEHICLES 1<sup>ST</sup> OWNER

Name: \_\_\_\_\_

Street: \_\_\_\_\_

City: \_\_\_\_\_

Telephone: \_\_\_\_\_

Stamp of maintenance partner

Telephone: \_\_\_\_\_

### VEHICLES 3<sup>RD</sup> OWNER

Name: \_\_\_\_\_

Street: \_\_\_\_\_

City: \_\_\_\_\_

Telephone: \_\_\_\_\_

Stamp of maintenance partner

Telephone: \_\_\_\_\_

### VEHICLES 2<sup>ND</sup> OWNER

Name: \_\_\_\_\_

Street: \_\_\_\_\_

City: \_\_\_\_\_

Telephone: \_\_\_\_\_

Stamp of maintenance partner

Telephone: \_\_\_\_\_

### VEHICLES 4<sup>TH</sup> OWNER

Name: \_\_\_\_\_

Street: \_\_\_\_\_

City: \_\_\_\_\_

Telephone: \_\_\_\_\_

Stamp of maintenance partner

Telephone: \_\_\_\_\_

## Maintenance interval and documentation

Date: \_\_\_\_\_ Km: \_\_\_\_\_

### Once a year or as required you must:

- Carefully remove the top section of the docking station (remove the two bolts on each side). See instructions on page 21.
- Clean the docking station.
- Clean the locking cylinder and locking pin and lubricate with light oil.
- Remove the locking pin if there are any signs of corrosion or damage (part no. 503555).
- Adjust the steel wire to the locking pin, part no. 502400, if necessary.
- All steel wires must be examined for signs of wear or evidence of breaks. Replace if necessary.
- Test whether the manual emergency release functions properly and if the emergency release tool is in the vehicle.
- Check whether the wires are loose in the terminals and whether they are intact and insulated. Replace if necessary.
- Test whether the electromagnet/solenoid functions correctly.
- Test whether the micro switch, part no. 503640, functions correctly.
- Test whether the warning tone (high-pitched howl) is activated and functions correctly.
- Test whether the light diodes in the control panel function correctly along with the warning tone.
- Check whether any nuts, bolts or screws are loose or damaged. Tighten/replace if necessary. This also applies to the lock plate and its fitting under the wheelchair.

Maintenance carried out:

**Stamp**

Replaced parts:

Next maintenance: Date : \_\_\_\_\_

**When the service lamp on control panel lights up, ... the VarioDock™ must undergo maintenance within 200 uses. Order service kit with part no. 503636 and replace all the parts in it (see also pages 34-35).**

### Check also:

- Carefully remove the top section of the docking station (remove the two bolts on each side). See instructions on page 21.
- Clean the docking station.
- Clean the locking cylinder and locking pin and lubricate with light oil.
- Remove the locking pin if there are any signs of corrosion or damage (art. no. 503555).
- Adjust the steel wire to the locking pin, art. no. 502400, if necessary.
- All steel wires must be examined for signs of wear or evidence of breaks. Replace if necessary.
- Test whether the manual emergency release functions properly and if the emergency release tool is in the vehicle.
- Check whether the wires are loose in the terminals and whether they are intact and insulated. Replace if necessary.
- Test whether the electromagnet/solenoid functions correctly.
- Test whether the micro switch, art. no. 503640, functions correctly.
- Test whether the warning tone (high-pitched howl) is activated and functions correctly.
- Test whether the light diodes in the control panel function correctly along with the warning tone.
- Check whether any nuts, bolts or screws are loose or damaged. Tighten/replace if necessary. This also applies to the lock plate and its fitting under the wheelchair.

## Maintenance interval and documentation

Date: \_\_\_\_\_ Km: \_\_\_\_\_

### Once a year or as required you must:

- Carefully remove the top section of the docking station (remove the two bolts on each side). See instructions on page 21.
- Clean the docking station.
- Clean the locking cylinder and locking pin and lubricate with light oil.
- Remove the locking pin if there are any signs of corrosion or damage (part no. 503555).
- Adjust the steel wire to the locking pin, part no. 502400, if necessary.
- All steel wires must be examined for signs of wear or evidence of breaks. Replace if necessary.
- Test whether the manual emergency release functions properly and if the emergency release tool is in the vehicle.
- Check whether the wires are loose in the terminals and whether they are intact and insulated. Replace if necessary.
- Test whether the electromagnet/solenoid functions correctly.
- Test whether the micro switch, part no. 503640, functions correctly.
- Test whether the warning tone (high-pitched howl) is activated and functions correctly.
- Test whether the light diodes in the control panel function correctly along with the warning tone.
- Check whether any nuts, bolts or screws are loose or damaged. Tighten/replace if necessary. This also applies to the lock plate and its fitting under the wheelchair.

### Maintenance carried out:

Stamp

### Replaced parts:

Next maintenance: Date : \_\_\_\_\_

**When the service lamp on control panel lights up, ... the VarioDock™ must undergo maintenance within 200 uses. Order service kit with part no. 503636 and replace all the parts in it (see also pages 34-35).**

### Check also:

- Carefully remove the top section of the docking station (remove the two bolts on each side). See instructions on page 21.
- Clean the docking station.
- Clean the locking cylinder and locking pin and lubricate with light oil.
- Remove the locking pin if there are any signs of corrosion or damage (art. no. 503555).
- Adjust the steel wire to the locking pin, art. no. 502400, if necessary.
- All steel wires must be examined for signs of wear or evidence of breaks. Replace if necessary.
- Test whether the manual emergency release functions properly and if the emergency release tool is in the vehicle.
- Check whether the wires are loose in the terminals and whether they are intact and insulated. Replace if necessary.
- Test whether the electromagnet/solenoid functions correctly.
- Test whether the micro switch, art. no. 503640, functions correctly.
- Test whether the warning tone (high-pitched howl) is activated and functions correctly.
- Test whether the light diodes in the control panel function correctly along with the warning tone.
- Check whether any nuts, bolts or screws are loose or damaged. Tighten/replace if necessary. This also applies to the lock plate and its fitting under the wheelchair.

## Maintenance interval and documentation

Date: \_\_\_\_\_ Km: \_\_\_\_\_

### Once a year or as required you must:

- Carefully remove the top section of the docking station (remove the two bolts on each side). See instructions on page 21.
- Clean the docking station.
- Clean the locking cylinder and locking pin and lubricate with light oil.
- Remove the locking pin if there are any signs of corrosion or damage (part no. 503555).
- Adjust the steel wire to the locking pin, part no. 502400, if necessary.
- All steel wires must be examined for signs of wear or evidence of breaks. Replace if necessary.
- Test whether the manual emergency release functions properly and if the emergency release tool is in the vehicle.
- Check whether the wires are loose in the terminals and whether they are intact and insulated. Replace if necessary.
- Test whether the electromagnet/solenoid functions correctly.
- Test whether the micro switch, part no. 503640, functions correctly.
- Test whether the warning tone (high-pitched howl) is activated and functions correctly.
- Test whether the light diodes in the control panel function correctly along with the warning tone.
- Check whether any nuts, bolts or screws are loose or damaged. Tighten/replace if necessary. This also applies to the lock plate and its fitting under the wheelchair.

### Maintenance carried out:

Stamp

### Replaced parts:

Next maintenance: Date : \_\_\_\_\_

**When the service lamp on control panel lights up, ... the VarioDock™ must undergo maintenance within 200 uses. Order service kit with part no. 503636 and replace all the parts in it (see also pages 34-35).**

### Check also:

- Carefully remove the top section of the docking station (remove the two bolts on each side). See instructions on page 21.
- Clean the docking station.
- Clean the locking cylinder and locking pin and lubricate with light oil.
- Remove the locking pin if there are any signs of corrosion or damage (art. no. 503555).
- Adjust the steel wire to the locking pin, art. no. 502400, if necessary.
- All steel wires must be examined for signs of wear or evidence of breaks. Replace if necessary.
- Test whether the manual emergency release functions properly and if the emergency release tool is in the vehicle.
- Check whether the wires are loose in the terminals and whether they are intact and insulated. Replace if necessary.
- Test whether the electromagnet/solenoid functions correctly.
- Test whether the micro switch, art. no. 503640, functions correctly.
- Test whether the warning tone (high-pitched howl) is activated and functions correctly.
- Test whether the light diodes in the control panel function correctly along with the warning tone.
- Check whether any nuts, bolts or screws are loose or damaged. Tighten/replace if necessary. This also applies to the lock plate and its fitting under the wheelchair.

## Maintenance interval and documentation

Date: \_\_\_\_\_ Km: \_\_\_\_\_

### Once a year or as required you must:

- Carefully remove the top section of the docking station (remove the two bolts on each side). See instructions on page 21.
- Clean the docking station.
- Clean the locking cylinder and locking pin and lubricate with light oil.
- Remove the locking pin if there are any signs of corrosion or damage (part no. 503555).
- Adjust the steel wire to the locking pin, part no. 502400, if necessary.
- All steel wires must be examined for signs of wear or evidence of breaks. Replace if necessary.
- Test whether the manual emergency release functions properly and if the emergency release tool is in the vehicle.
- Check whether the wires are loose in the terminals and whether they are intact and insulated. Replace if necessary.
- Test whether the electromagnet/solenoid functions correctly.
- Test whether the micro switch, part no. 503640, functions correctly.
- Test whether the warning tone (high-pitched howl) is activated and functions correctly.
- Test whether the light diodes in the control panel function correctly along with the warning tone.
- Check whether any nuts, bolts or screws are loose or damaged. Tighten/replace if necessary. This also applies to the lock plate and its fitting under the wheelchair.

### Maintenance carried out:

Stamp

### Replaced parts:

Next maintenance: Date : \_\_\_\_\_

**When the service lamp on control panel lights up, ... the VarioDock™ must undergo maintenance within 200 uses. Order service kit with part no. 503636 and replace all the parts in it (see also pages 34-35).**

### Check also:

- Carefully remove the top section of the docking station (remove the two bolts on each side). See instructions on page 21.
- Clean the docking station.
- Clean the locking cylinder and locking pin and lubricate with light oil.
- Remove the locking pin if there are any signs of corrosion or damage (art. no. 503555).
- Adjust the steel wire to the locking pin, art. no. 502400, if necessary.
- All steel wires must be examined for signs of wear or evidence of breaks. Replace if necessary.
- Test whether the manual emergency release functions properly and if the emergency release tool is in the vehicle.
- Check whether the wires are loose in the terminals and whether they are intact and insulated. Replace if necessary.
- Test whether the electromagnet/solenoid functions correctly.
- Test whether the micro switch, art. no. 503640, functions correctly.
- Test whether the warning tone (high-pitched howl) is activated and functions correctly.
- Test whether the light diodes in the control panel function correctly along with the warning tone.
- Check whether any nuts, bolts or screws are loose or damaged. Tighten/replace if necessary. This also applies to the lock plate and its fitting under the wheelchair.

## Maintenance interval and documentation

Date: \_\_\_\_\_ Km: \_\_\_\_\_

### Once a year or as required you must:

- Carefully remove the top section of the docking station (remove the two bolts on each side). See instructions on page 21.
- Clean the docking station.
- Clean the locking cylinder and locking pin and lubricate with light oil.
- Remove the locking pin if there are any signs of corrosion or damage (part no. 503555).
- Adjust the steel wire to the locking pin, part no. 502400, if necessary.
- All steel wires must be examined for signs of wear or evidence of breaks. Replace if necessary.
- Test whether the manual emergency release functions properly and if the emergency release tool is in the vehicle.
- Check whether the wires are loose in the terminals and whether they are intact and insulated. Replace if necessary.
- Test whether the electromagnet/solenoid functions correctly.
- Test whether the micro switch, part no. 503640, functions correctly.
- Test whether the warning tone (high-pitched howl) is activated and functions correctly.
- Test whether the light diodes in the control panel function correctly along with the warning tone.
- Check whether any nuts, bolts or screws are loose or damaged. Tighten/replace if necessary. This also applies to the lock plate and its fitting under the wheelchair.

### Maintenance carried out:

Stamp

### Replaced parts:

Next maintenance: Date : \_\_\_\_\_

**When the service lamp on control panel lights up, ... the VarioDock™ must undergo maintenance within 200 uses. Order service kit with part no. 503636 and replace all the parts in it (see also pages 34-35).**

### Check also:

- Carefully remove the top section of the docking station (remove the two bolts on each side). See instructions on page 21.
- Clean the docking station.
- Clean the locking cylinder and locking pin and lubricate with light oil.
- Remove the locking pin if there are any signs of corrosion or damage (art. no. 503555).
- Adjust the steel wire to the locking pin, art. no. 502400, if necessary.
- All steel wires must be examined for signs of wear or evidence of breaks. Replace if necessary.
- Test whether the manual emergency release functions properly and if the emergency release tool is in the vehicle.
- Check whether the wires are loose in the terminals and whether they are intact and insulated. Replace if necessary.
- Test whether the electromagnet/solenoid functions correctly.
- Test whether the micro switch, art. no. 503640, functions correctly.
- Test whether the warning tone (high-pitched howl) is activated and functions correctly.
- Test whether the light diodes in the control panel function correctly along with the warning tone.
- Check whether any nuts, bolts or screws are loose or damaged. Tighten/replace if necessary. This also applies to the lock plate and its fitting under the wheelchair.



## Maintenance interval and documentation

Date: \_\_\_\_\_ Km: \_\_\_\_\_

### Once a year or as required you must:

- Carefully remove the top section of the docking station (remove the two bolts on each side). See instructions on page 21.
- Clean the docking station.
- Clean the locking cylinder and locking pin and lubricate with light oil.
- Remove the locking pin if there are any signs of corrosion or damage (part no. 503555).
- Adjust the steel wire to the locking pin, part no. 502400, if necessary.
- All steel wires must be examined for signs of wear or evidence of breaks. Replace if necessary.
- Test whether the manual emergency release functions properly and if the emergency release tool is in the vehicle.
- Check whether the wires are loose in the terminals and whether they are intact and insulated. Replace if necessary.
- Test whether the electromagnet/solenoid functions correctly.
- Test whether the micro switch, part no. 503640, functions correctly.
- Test whether the warning tone (high-pitched howl) is activated and functions correctly.
- Test whether the light diodes in the control panel function correctly along with the warning tone.
- Check whether any nuts, bolts or screws are loose or damaged. Tighten/replace if necessary. This also applies to the lock plate and its fitting under the wheelchair.

### Maintenance carried out:

Stamp

### Replaced parts:

Next maintenance: Date : \_\_\_\_\_

**When the service lamp on control panel lights up, ... the VarioDock™ must undergo maintenance within 200 uses. Order service kit with part no. 503636 and replace all the parts in it (see also pages 34-35).**

### Check also:

- Carefully remove the top section of the docking station (remove the two bolts on each side). See instructions on page 21.
- Clean the docking station.
- Clean the locking cylinder and locking pin and lubricate with light oil.
- Remove the locking pin if there are any signs of corrosion or damage (art. no. 503555).
- Adjust the steel wire to the locking pin, art. no. 502400, if necessary.
- All steel wires must be examined for signs of wear or evidence of breaks. Replace if necessary.
- Test whether the manual emergency release functions properly and if the emergency release tool is in the vehicle.
- Check whether the wires are loose in the terminals and whether they are intact and insulated. Replace if necessary.
- Test whether the electromagnet/solenoid functions correctly.
- Test whether the micro switch, art. no. 503640, functions correctly.
- Test whether the warning tone (high-pitched howl) is activated and functions correctly.
- Test whether the light diodes in the control panel function correctly along with the warning tone.
- Check whether any nuts, bolts or screws are loose or damaged. Tighten/replace if necessary. This also applies to the lock plate and its fitting under the wheelchair.

## User Guide – Operation of the VarioDock™

Please refer to the description of VarioDock™ on page 14. The user must read these instructions in full prior to using the equipment.

### Securing the wheelchair in the VarioDock™

1. The user must be driven forward, but not into the docking station. Now the height of the wheelchair must be adjusted on the control panel (it is the vehicle adapter/workshop that must specify the height of the lock plate and write on the supplied sticker).
2. The VarioDock™ is equipped with a control switch which indicates whether the lock plate is properly engaged in the docking station. As soon as the locking plate touches the locking pin, a warning tone is heard and the red LED (LED) in the control panel lights up until the locking plate is fully in place or the wheelchair is driven away from the docking station.
3. As an indication that the wheelchair is properly secured, the warning tone will cease, the red diode in the control panel will go out and the green diode lamp (LED) will light up.
4. By pressing the blue button on the control panel, the docking station can be pulled down/tightened so that unwanted slack is reduced while driving. DO NOT press the green button to pull the docking downwards, as the force which tightens the docking station is not regulated, which may cause damage to the wheelchair.
5. When the wheelchair is correctly secured, the safety belt should be fitted and adjusted so that it fits the user.  
**Do not drive the vehicle whilst a wheelchair is being manoeuvred into position in the docking station. In general, do not use the vehicle if the wheelchair is not correctly secured, the warning tone sounds and/or the red warning lamp (LED)**

**in the control panel flashes or is lit! Therefore, always check if the lock plate is properly engaged in the docking station by trying to back the wheelchair out of the docking station before moving the vehicle. (It must not be possible to back out of the docking station without pressing the red button in the control panel).**

### Release from the VarioDock™

1. When the vehicle has been brought to a halt, remove the safety belt.
  2. Press the release button on the control panel (see page 15, F), and the docking station will then automatically drive upwards to the original height. The locking pin is released for either 5 or 8 seconds (optional). The red LED lights up and a warning tone is heard. The locking pin is then automatically locked / activated again. Do not try to back out of the docking station until the red LED in the control panel, indicating the release position, is lit.
- WARNING!**  
**Attempting to reverse the wheelchair before the red LED has been illuminated will result in blocking the docking station's lock mechanism which makes it impossible to reverse. If this happens repeat the above unlocking procedure.**
3. Move the wheelchair away from the docking station within the 5 or 8 second period.

**If the locking pin is not released when you press the red button in the control panel**

1. In the event of electrical failure, a manual emergen-

cy release is located at the front edge of the docking station. Push the red release arm to one side and hold it there while the wheelchair moves away.

2. An emergency release tool in red is delivered with each VarioDock. This has to be pushed between the lock plate of the wheelchair and the docking station to release the wheelchair.

**VarioDock™, seat belts and components should be inspected at least once a year in accordance with the maintenance interval and documentation.**

### Safety belts (Accessory for VarioDock™)

Safety belts must be inspected and cleaned regularly. Replace belts or straps that have faded in the sun, are worn at the edges, have tears or show clear signs of wear. Components that are damaged or worn must also be replaced. Avoid soiling the belts with chemicals, polishing agents, oil or, in particular, battery acid.

### Cleaning the belts:

Wash by hand with hot water and mild soap. Rinse thoroughly with water and allow to dry in the shade. Do not expose the belts to direct sunlight and never use powerful cleaning agents. Only moving metal parts that are not in contact with belt webbing should be lubricated with light oil when necessary, and, if so, very carefully. Never lubricate inertia reels or other components that are part of the safety belt. Never let the belt webbing come into contact with oil or grease.

## Functional description

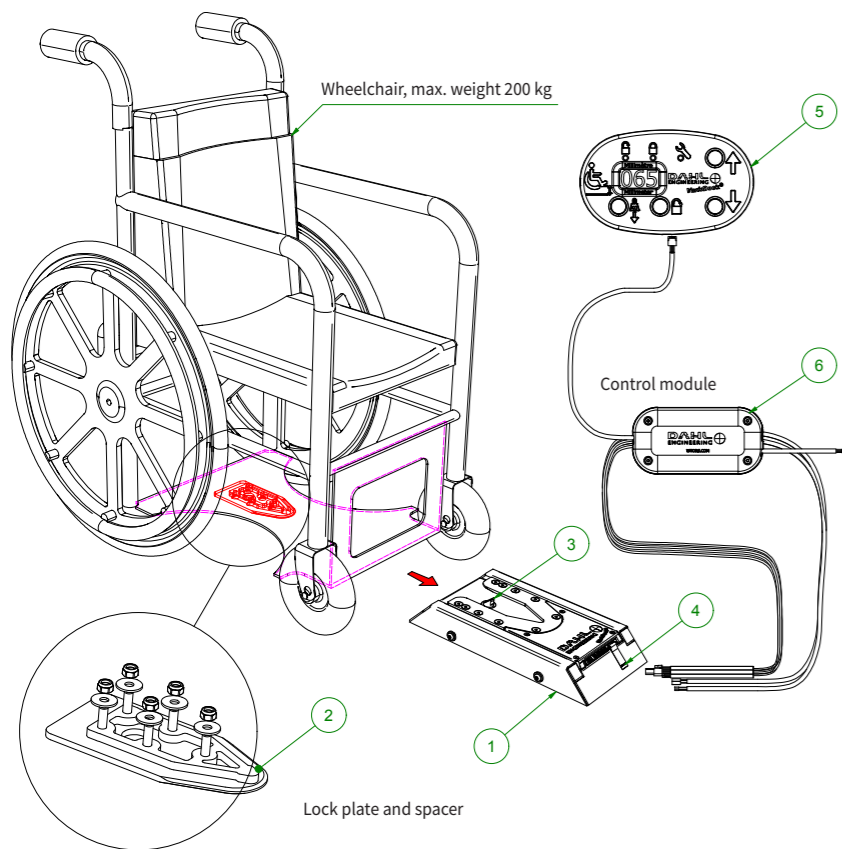

The Dahl VarioDock™ (1) is designed to retain manual and electric wheelchairs, as well as Dahl's seat bases in the vehicle's floor. A control module (6) controls and monitors Dahl VarioDock™'s features, distributes power to the various components, as well as receiving and sending signals to and from the control panel. Wires are included. Do not carry out any modifications to the supplied wiring or other components. A lock plate and an 8mm spacer (2) must be fitted under the wheelchair. When the wheelchair is manoeuvred towards the VarioDock, the wheelchair is guided into place by means of the lock plate.

When the lock plate is fully engaged in the VarioDock, a spring-loaded lock pin (3) automatically secures the lock plate. VarioDock is equipped with a built-in control switch that indicates whether the lock plate is correctly secured in the VarioDock. As soon as the lock plate comes into contact with the locking pin, a warning tone will sound (a high-pitched howl), and the red diode/lamp - LED (A) in the control panel will light up until the lock plate is either fully engaged or else the wheelchair is removed from the VarioDock. With the wheelchair correctly secured, the warning tone stops and the green diode/lamp - LED (B) in the control panel will light up to indicate that the wheelchair is properly secured. The control panel (5) (see descriptions of control panel's functions on page 15) is connected to an electromagnet which triggers/releases the lock pin for approx. 5 or 8 seconds, after which it is automatically locked once more.

In case of an electrical fault, there is a manual emergency release (4) on the front edge of the VarioDock. The release arm should be pushed sideways and held in order to release the wheelchair. You can also use the emergency release tool, which is delivered with the VarioDock. Fixing parts in the form of bolts, nuts, washers, etc., are included.

## Control panel

To minimize standby power consumption to 8 mA, the display can be set to "standby mode". Please find more information in the chapter "Electrical connection".



When in standby mode, press one of the four coloured buttons in order to switch display on. If the display is frozen, you can reset the software by pressing the up and down buttons of the control panel simultaneously for 3 seconds.

|   |   |
|---|---|
| A | <b>Red diode lights up:</b><br>Wheelchair is not secured and can be released from the VarioDock™  |
| B | <b>Green diode lights up:</b><br>Wheelchair is secured.   |
| C | Lamp lights up when parts that are subject to regular wear and tear must be replaced.   |
| D | <b>Yellow button:</b> Adjusts upwards. Keep button pressed, to increase step length, allowing quicker adjustment. Press button once to adjust in steps of 1mm.  |
| E | <b>Green button:</b> Adjusts downwards. Keep button pressed, to increase step length, allowing quicker adjustment. Press button once to adjust in steps of 1mm. |
| F | <b>Red button:</b> Unlocks the VarioDock™   |
| G | <b>Blue button:</b> Pulls docking station down to reduce unwanted slack.  |
| H | Symbol for wheelchair's ground clearance.   |
| I | Display shows the ground clearance of VarioDock™ (wheelchair's ground clearance must be measured, see instructions on page 16).                                 |



## Installation of Dahl VarioDock™

Installation must be carried out by a qualified and experienced technician/fitter.

In the area where the wheelchair is to be locked into the docking system, the floor must be flat along the full length and width of the wheelchair. The length of the flat floor must be such that it is possible to manoeuvre the wheelchair into the docking system without problems. It is essential that there is no difference in the height of the floor from one side to the other at the location where the docking station is to be installed. It is also important that the lock plate is fitted straight/horizontally under the wheelchair. If the above is not carried out carefully, there is a risk that the wheelchair may not be manoeuvred properly into place in the docking station.

### 1. Delivery of VarioDock™

- A. VarioDock™ is installed on a plate for transport when delivered to avoid damage during transport. Remove this plate and the 6 bolts before installing. See also instructions 5 and 6 on page 17.

### 2. Installing the lock plate

- A. Install the lock plate and 8 mm spacer under the wheelchair in accordance with the wheelchair manufacturer's instructions, which can be downloaded from our website, as well as instructions on the drawings on pages 5 and 14. Before the lock plate and spacer are installed, carry out the following:
- B. The installer must make sure that the wheelchair has a solid construction at the place where the lock plate shall be installed which can withstand the load during a collision. On our website <http://wtors.com> you can see the list with all approved adaptation kits for wheelchairs and download

manufacturers' instructions for use and assembly, which must be followed when installing the lock plate and spacer.

- C. Be aware that bolts with art.no. # 502800 for securing the lock plate are custom made bolts, which are only available in one length. It is very important that the installer carefully adjusts the bolts to the correct length, which fits the individual wheelchair's approved adaptation kit with spacers, if applicable. If the bolts are too short to fully engage into the entire thread depth, they will not be strong enough to withstand the load during a collision. If the bolts are too long, the batteries or other wheelchair components may be damaged. Therefore be careful when shortening the bolts.

**Warning!** Never use bolts other than original Dahl bolts # 502800 for fixing the lock plate. Standard bolts are not strong enough to withstand a collision.

### 3. Measuring ground clearance

- A. For correct determination of the wheelchair's ground clearance, it must be measured with the user seated in the wheelchair (pay attention to correct tyre pressure). Carefully drive the wheelchair into the VarioDock™ and set the height of VarioDock™ so that there is 2 mm space between the underside of the lock plate and docking station.
- B. Read the ground clearance off the display and write it on the supplied sticker (see the design of the sticker on the right).

### 4. Location of VarioDock™

- A. Place the wheelchair, with the user sitting in it, facing forward in the vehicle at the desired installation location. If the user is the driver of the vehicle,

make sure that the user can reach and operate all necessary instruments and driving functions in a proper and safe manner from this position.

- B. Place the docking station under the wheelchair.  
C. Mark the docking station's position on the floor and the lock plate's position (in width and length) under the wheelchair.

### 5. Beginning installation work

Ask the wheelchair user to leave the vehicle, so that installation work can begin.

- A. Drive the VarioDock™ to the lowest position (61mm) before you begin installation work.  
B. Loosen the 4 bolts on the side of the VarioDock™ (important: note instructions on page 21!) and **carefully** remove the top section of the docking station. See pictures 3 and 4 on page 17. (Please note that electronic components are installed in the top section!). Mark the location of the bolts on the floor of the vehicle, and drill holes through the floor at these locations. Be careful when marking and drilling through the vehicle floor to avoid damage to brake pipes, wires, fuel tank and the like. Never drill any holes until you are certain that the holes match the location of the installation components.  
C. Secure the docking station with the supplied bolts, nuts, etc. See illustrations pages 18 and 19.



## Installation of Dahl VarioDock™

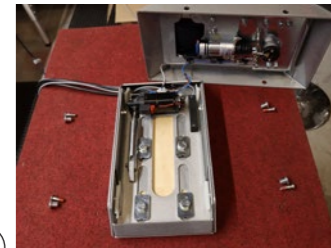

### Removal of top section

Pictures 1-6

1. Loosen bolts, see instructions 3 on page 21
2. Bolts are loosened
3. Carefully remove the top section
4. Place top section as shown on picture
5. Plate and 6 bolts used for transportation of the VarioDock™, shown on picture 6, must be dismantled and discarded!
6. The transportation plate and bolts are now removed

### Fitting the top section

Picture 7

When assembling the slide and bottom frames, the pin of the potentiometer must be carefully placed in the hole of the bottom frame, otherwise there is a risk of damaging the potentiometer. If the docking station is tightened when the pin is not inserted in the hole, the potentiometer will be destroyed/damaged.



Drill holes in the anchorage plate for running through cables, if necessary.



## Fitting examples

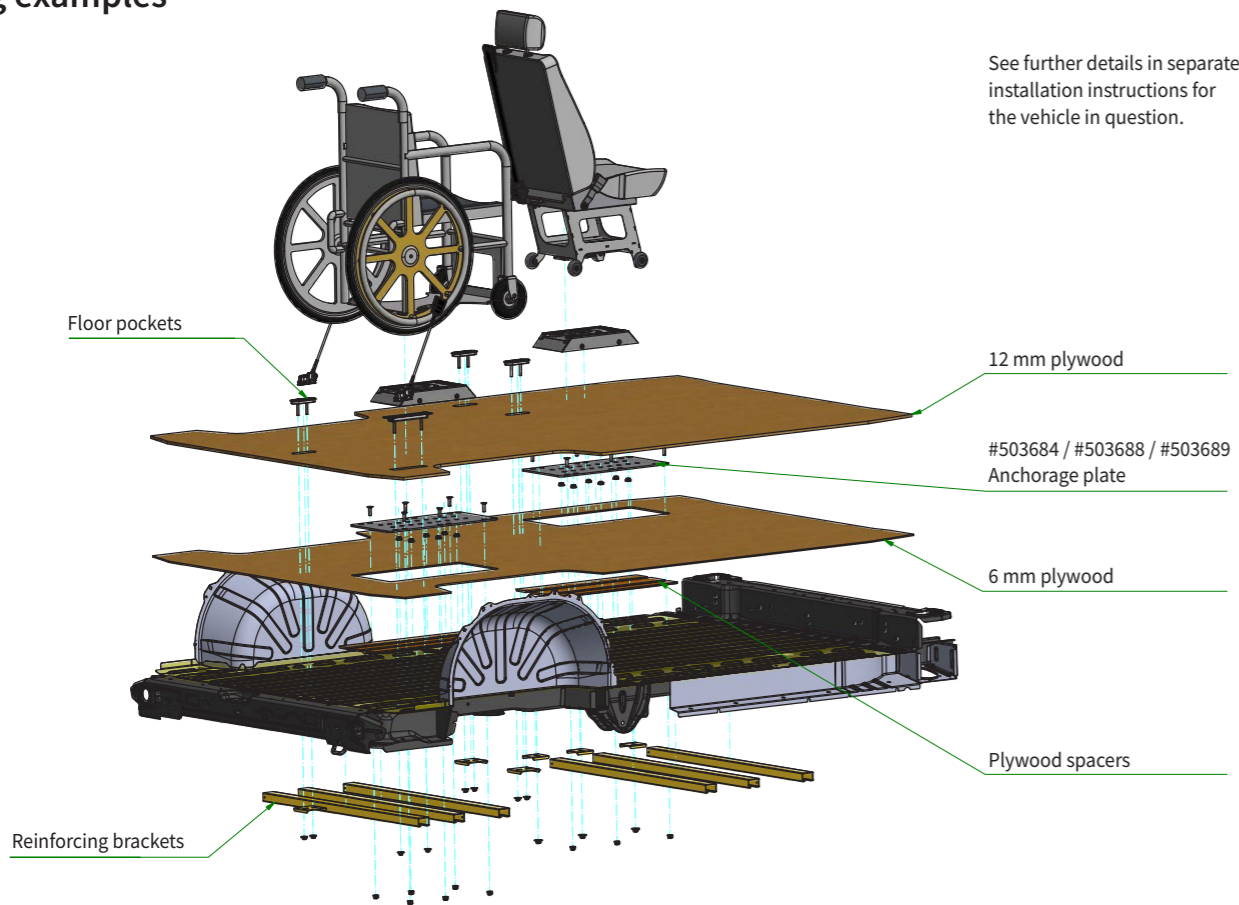

## Fitting examples

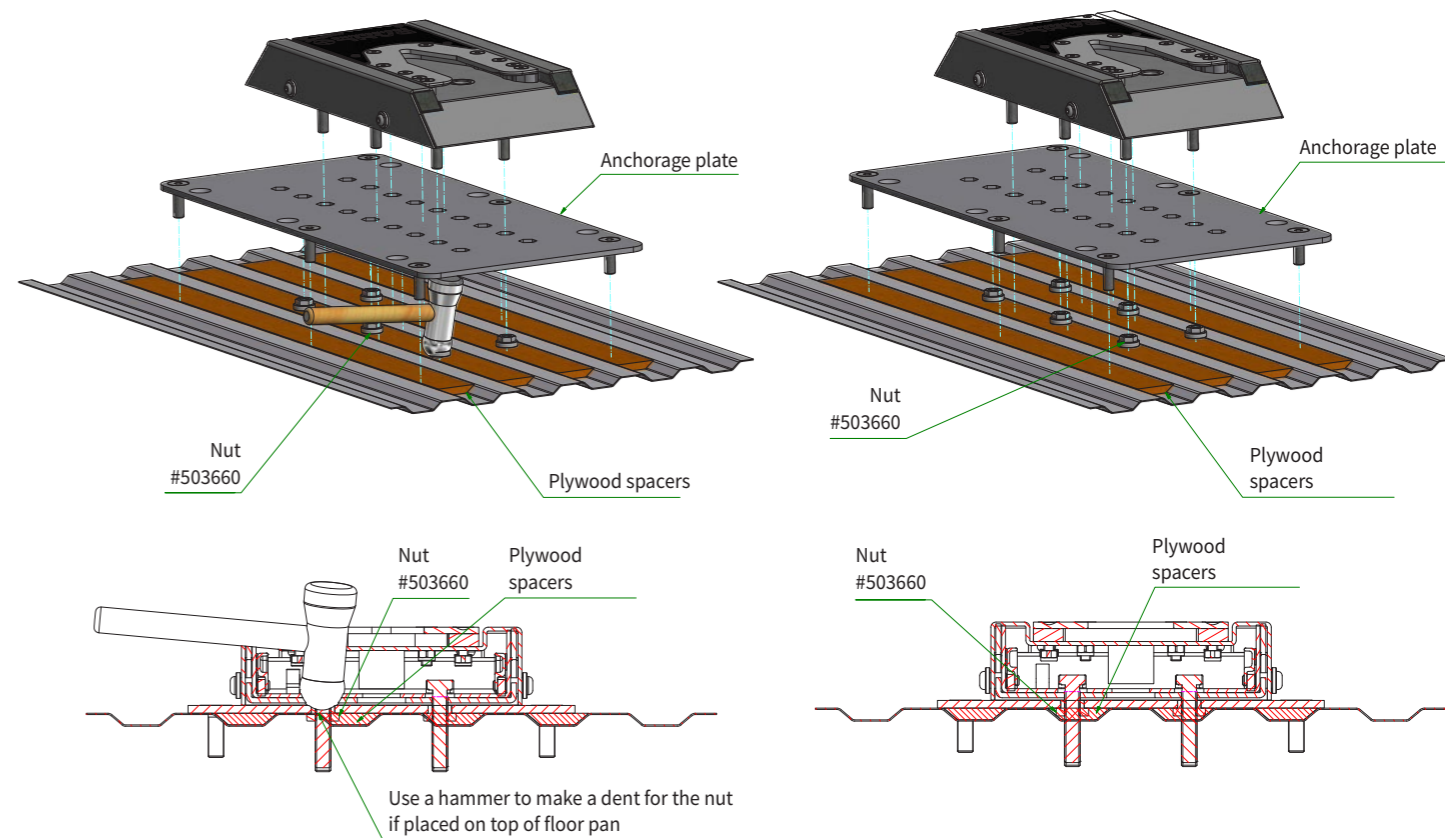

## Fitting examples

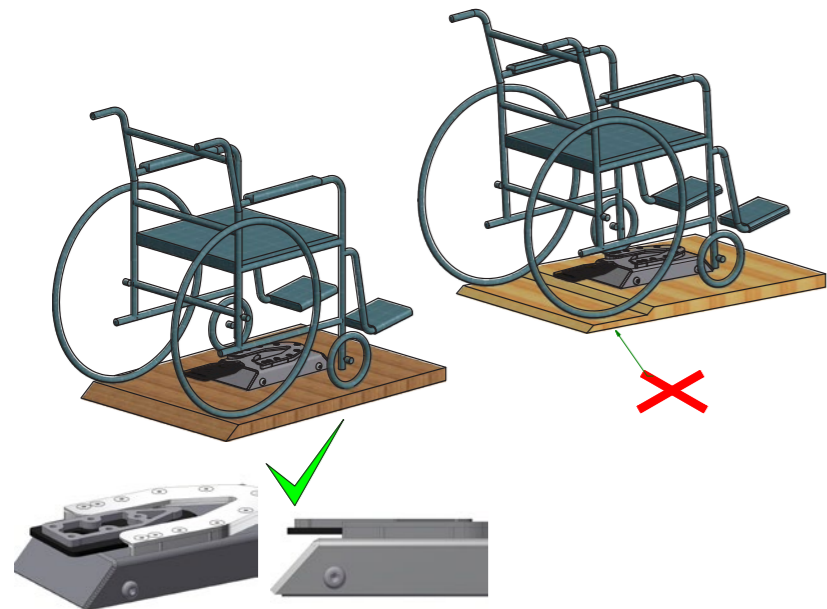

To allow tire wear as well as floor carpet getting compressed/worn - adjust the lock plate to be positioned at the top of the gap for the lock plate.  
Using vinyl or another hard surface that will not get compressed or worn like floor carpet is recommended.



### WARNING!

In countries where legislation demands meeting EU-Regulation 2018/858, Annex II, Part III, Appendix 3 relating to vehicles fitted for wheelchairs, a fitting kit **MUST** be used, which has been tested in the position and the specific vehicle the wheelchair will be used in, for fitting the docking system and safety belts for the wheelchair user.

Please enquire with regard to the current range of vehicle specific fitting kits with corresponding fitting instructions.

If a vehicle specific fitting instruction exists, it must be requested from Dahl Engineering and followed when fitting safety belts, floor pockets, floor rails and docking station.

The following fitting examples for fitting the Dahl VarioDock can only be used in countries where no legal requirements for tests of docking systems in the specific vehicle and mounting position are to be found.

**We always recommend using a fitting kit which has been tested in the specific vehicle and which meets EU-regulation 2018/858.**

## Tightening torques

1. Art.no. 503125 – Dahl lock plate and 8mm spacer, with Dahl Special Bolts #502800

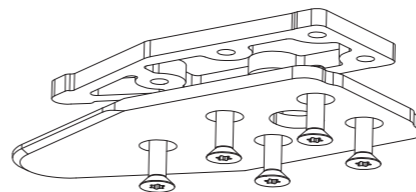

These bolts must be tightened with 16-18 Nm and secured with Loctite 222 or equivalent.

### BE CAREFUL:

When tightening nuts and bolts, they must not be tightened so hard that the floor profiles are compressed or deformed. Carefully tighten the bolts until the profiles in the floor of the vehicle begin to give, though never more than the specified maximum tightening torque for the bolt concerned.

### Corrosion protection

All holes and installation elements under the floor of the vehicle should be treated with an anti-corrosion agent. Please also be aware of the vehicle manufacturer's guidelines, if available, for corrosion protection. To avoid water penetrating the holes in the floor of the vehicle, sealant must be applied to the holes.

2. Art.no. 502685 and 502735, bolts inside the VarioDock™

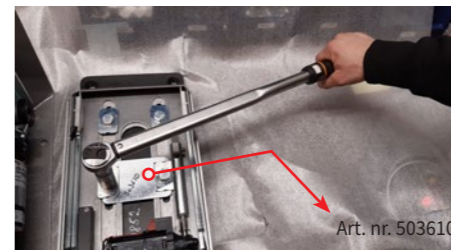

All 6 bolts inside the VarioDock™ must be tightened with 40 Nm. All other M8 bolts have to be tightened with 20-25 Nm. It is important to tighten these bolts correctly. If the vehicle floor is not level, it will lead to unnecessary wear and malfunction, and in the worst case result in malfunction of the height adjusting function of VarioDock™.



If bolts are tightened with more than 40 Nm, the docking station will not function properly and there will be permanent damage to the bottom frame.

When tightening the bolts, please use fitting tool with art.no. #503610 to prevent washers turning out of position. Please remove the fitting tool after use.

3. Art.no. 502839 – bolts on the side of the VarioDock™

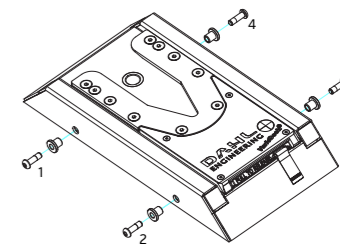

Loosen and tighten bolts in order 1-4. Before tightening, make sure all the bolts are engaged in the thread. Otherwise, there is a risk that the latches inside the docking station may fall out of position. Bolts on the side of the docking station must be tightened to 0.3mm slack between bolt and bushing so that the bushing can rotate. Test if the lock coating on the bolts works so the bolts cannot loosen during use.

→ The lock coating on the bolts # 502839 can be installed / removed max. 5 times. Thereafter, the bolts must be replaced with new ones.



### WARNING!

**Risk of death or serious injury**  
If bolts are not properly secured and they come loose, the docking station cannot secure the wheelchair, thereby causing risk of death or serious injury for the wheelchair user and the vehicle's other passengers.



## Electrical connection

1. Disconnect the cable on the battery's negative terminal.
2. Find a suitable installation site for the control panel.  
**If the docking station is used by a person driving the vehicle himself**  
 – At an easily accessible and visible location when the wheelchair is secured in the docking station and the driver is looking forward from the driving position.  
**If the docking station is for a passenger** – At a location which is visible when the driver of the vehicle is sitting in the driver's seat and looking forward.
3. Wiring must be installed so that it is not exposed to mechanical loads such as wear, vibrations, kinks and sharp edges which can cause breaks and result in malfunctions or, in the worst case, a short circuit. To ensure sufficient power supply to the docking station, the supply cable must be installed directly to the vehicle's battery, otherwise there is a risk of malfunction and overload of the vehicle's original wiring. The power supply must be fused with a 30 amp fuse (not included.) See the wiring diagram on page 24 for correct connection.
4. **Electrical connection**  
 - To reset the maintenance counter, press the reset button down on the circuit board for approx. 15 seconds. The yellow LED on the control panel flashes when the reset is done.  
 - Parking brake (1) and (2): Polarity is not important.  
 - You can reset the software by pressing the up and down buttons of the control panel simultaneously for 3 seconds.  
 - Function when lock pin is blocked: To protect the electrical system from overload, the power supply for the locking mechanism will pulsate if blocking the lock pin. This can be heard as pulsating/ clicking sound from inside the docking station.

### Settings on DIP switches

When changing DIP switch settings, the software must be reset to save changes.

DIP 1 og DIP 2:

Setting the tightening rate by pressing the blue button on the control panel

If VarioDock is to be used for multiple wheelchairs, we recommend choosing a low tightening rate to avoid any damage to the wheelchairs due to excessive pulling.

! **NOTE:** Please enquire from the wheelchair manufacturer whether the wheelchair may be pulled down, in order to avoid damage to the wheelchair.

| DIP 1 | DIP 2 | Tightening rate |
|-------|-------|-----------------|
| OFF   | OFF   | 20 kg +/- 15    |
| OFF   | ON    | 30 kg +/- 15    |
| ON    | OFF   | 45 kg +/- 15    |
| ON    | ON    | 60 kg +/- 15    |

DIP 3: Holding time of the lock pin

| DIP 3 | Holding time of the lock pin |
|-------|------------------------------|
| OFF   | 5 seconds                    |
| ON    | 8 seconds                    |

DIP 4: Activation of parking brake

| DIP 4 | Parking brake contact function: NO or NC   |
|-------|--|
| OFF   | If a signal is connected when the parking brake is being activated, so that 12V can be measured on the control unit's parking brake terminals 1 and 2 (polarity is irrelevant), switch 4 on DIP switch must be set to OFF (NO function). |
| ON    | If a signal is cut off when the parking brake is activated, so that 12 V CANNOT be measured on the control module's parking brake terminals 1 and 2 (polarity is irrelevant), switch 4 on DIP switch must be set to ON (NC function).    |

DIP 5: Standby mode option

The display panel, which shows the ground clearance (see fig. 1 on page 15) can be set to be permanently illuminated or switch off after 30 seconds by setting DIP 5 to OFF.

Thereby, the standby consumption of the docking station can be reduced from 23 to 8 mA. The display panel turns back on for 30 seconds by touching one of the buttons on the control panel.

| DIP 5 | Display state                            |
|-------|--|
| OFF   | Display will switch off after 30 seconds |
| ON    | Display is permanently active            |

DIP 6: No function

DIP 7 og DIP 8: Calibration of the height

Prior to calibration, it must be ensured that VarioDock can be adjusted within the full range of travel (61-91mm)! Settings **MUST** be made in the order shown.

| DIP 7 | DIP 8 | Function   |
|-------|-------|--|
| OFF   | OFF   | 1. Adjust VarioDock™ to approx. middle of the full range of travel   |
| ON    | OFF   | 2. Adjust the VarioDock™ to the top position - wait until it stops by itself, before releasing the button    |
| ON    | OFF   | 3. Adjust the VarioDock™ to the bottom position - wait until it stops by itself, before releasing the button |
| ON    | ON    | 4. Set the display to lowest position in millimetres (61mm) with the up / down buttons                       |
| ON    | OFF   | 5. Adjust the VarioDock™ to the top position - wait until it stops by itself, before releasing the button    |
| ON    | ON    | 6. Set the display to highest position in millimetres (91mm) with the up / down buttons                      |
| OFF   | OFF   | 7. The settings are complete   |

5. Carefully fit the docking station's top. It is important that the potentiometer pin be placed in the hole in the bottom frame when assembling slides and bottom frames. Otherwise there is a risk of damaging the potentiometer. If the docking station's top is fitted and the potentiometer is not sitting properly in the hole, it will be damaged. See instructions on page 17. Please be careful to place wires and cables so that they do not touch the moving parts.
6. Fit the cable onto the battery's negative terminal.

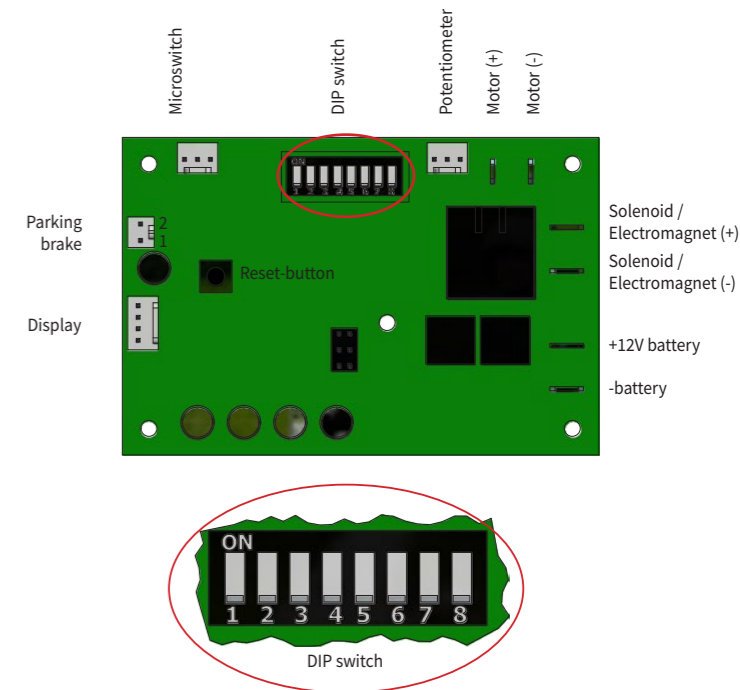

## Wiring diagram

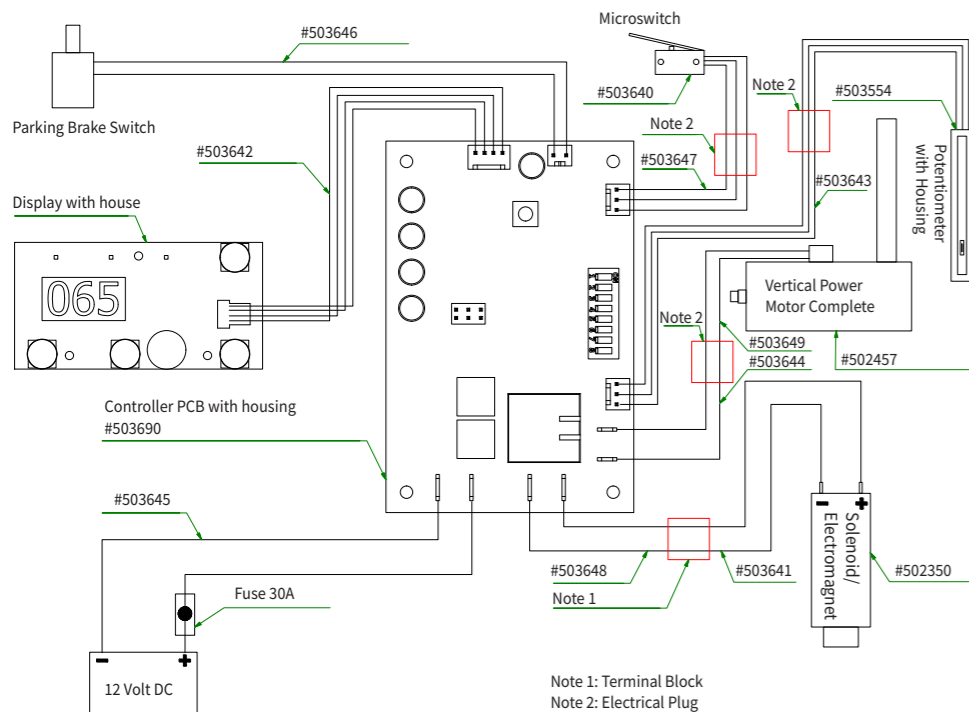

## Adjustment and final check

1. Check the function, operation and location of the docking station, control panel and safety belt with the user sitting in the wheelchair.
2. Check if all nuts and bolts are properly tightened.
3. Check if all wires and cables are free of the moving parts of the docking station and wheelchair.
4. Check if the manual emergency release mechanism functions correctly.
5. Instruct the user in the correct use of the manual release mechanism as well as the emergency release tool.
6. Instruct the user in the correct use of the docking station and go through all warnings contained in these instructions.
7. Inform the user of maintenance and inspection as stated in the maintenance interval and documentation.

You can find videos and more information about maintenance and installation of DAHL Vario-Dock™ on our website: <http://wtors.com>

## Emergency release tool

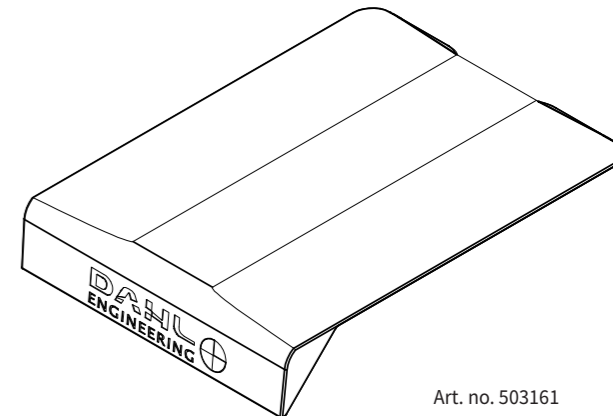
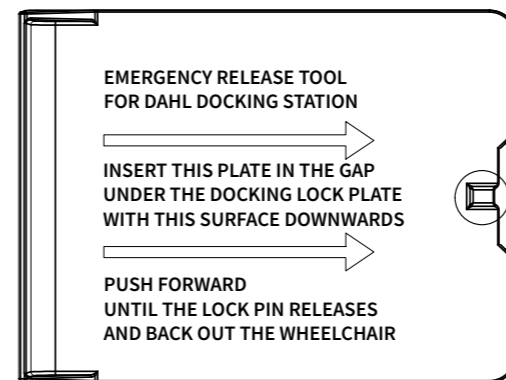



## Seat bases for original driver's seats

In addition to being approved for wheelchair tie-down, Dahl VarioDock™ has also been tested and approved for anchoring a number of original car manufacturers' seats.

We offer seat bases with pre-drilled holes that fit a number of car manufacturers' original driver's seats and their original seat heights. These seat bases can be anchored in the Dahl VarioDock™ and placed in the vehicle's 1st seat row, allowing the driver and passenger to swap places.

Our seat bases are tested in accordance with ECE Regulations 14 and 17.

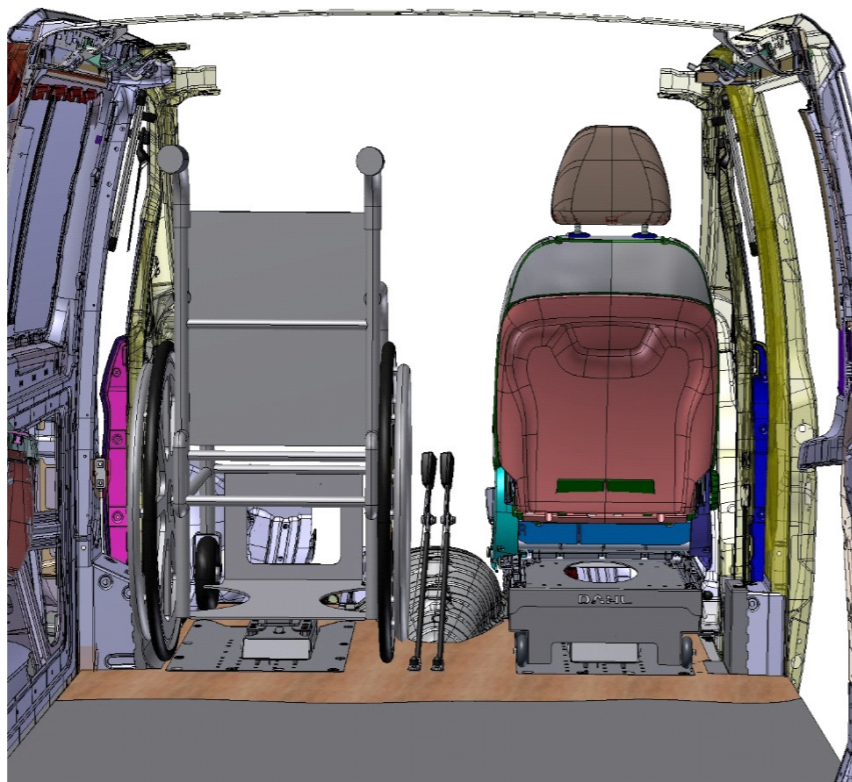

### **WARNING!** Risk of death or serious injury!

Do not use the VarioDock™ for anchoring a car seat which has not been tested and approved. Always make sure that the vehicle floor is approved for use of seats with integrated 3-point seat belt.

Please see current delivery programme with approved kits in our product catalogue, which can be downloaded from our website <http://wtors.com>

## Anchorage of Dahl COMFORT Seat with integrated 3-point seat belt

Dahl VarioDock™ has also been tested and approved for anchoring Dahl COMFORT Seat with integrated 3-point seat belt, placed on seat row 2 or behind, in a number of vehicle models.

Using VarioDock™ for anchoring the Dahl COMFORT Seat with an integrated 3-point seat belt requires a particularly strong reinforcement kit for the vehicle floor which is designed, tested and approved for the specific vehicle and installation position.

In the event of a collision, the vehicle's floor will be subjected to a much higher torque / load when using a seat with integrated seat anchorage points, than when using a wheelchair, where all seat anchorage points are rooted in the vehicle body and floor.

Please see the current delivery programme of approved and vehicle-specific anchoring kits in our product catalogue, which can be downloaded from our website <http://wtors.com>

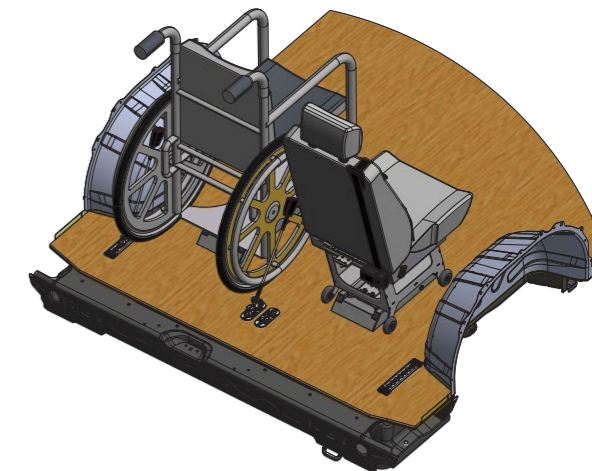

### **WARNING!** Risk of death or serious injury

Do not use VarioDock™ to anchor Dahl COMFORT Seats or other seats with integrated seat belt anchor points, if the vehicle has not been fitted with an approved reinforcement kit for VarioDock™.

If a reinforcement kit that has been approved for this use has not been fitted, there is a risk that the user and other passengers in the vehicle may suffer serious or fatal injuries during a collision as a result of the vehicle floor being deformed severely or the anchoring points of the docking station being torn loose.

Therefore, ask your dealer if a VarioDock™ reinforcement kit approved for anchorage of Dahl COMFORT Seat has been fitted to the vehicle and mounting position prior to commissioning.

## Recommendations for Clear Zones

Clear zones are recommended areas in which hard or sharp installation components or objects should not be placed. The clear zone recommendations in ISO 10542 are based on the way in which an occupant moves during a crash/collision. To reduce the risk of injuries to the head and chest, hard vehicle components and parts for WTORS which lie within the clear zones should be covered with padding that meets the requirements with regard to the hardness of materials as specified in FMVSS 201, ECE regulation no. 21 or EU directive 74/60.

The wheelchair and user must be placed facing forward in the vehicle.

**FCZ = Frontal Clear Zone**  
 650 mm. when both lap belts and diagonal belts are used.  
 950 mm. when only lap belts are used.

The use of both lap belts and diagonal belts is recommended to reduce the risk of head and chest impact. The majority of countries require the use of both lap belts and diagonal belts. It may be impossible to comply with the recommendation for FCZ if the wheelchair is used by a person driving the vehicle themselves.

**HHT= Seated head height**  
 Approx. 1200 mm for a small adult female. Approx. 1550 mm for a tall adult male.

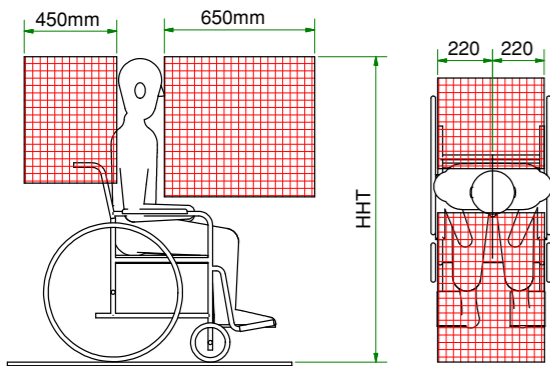

## Recommendations for use of safety belts for wheelchair users

Always use Dahl occupant restraint certified as WTORS. Only when installed in front row, use manufacturer's original equipped safety belt.

Please refer to Dahl Engineering's product catalog containing WTORS and certified safety belts.

Preferred and optional angles for location of the lap belt:

▲ = Preferred Zone / ■ = Optional Zone

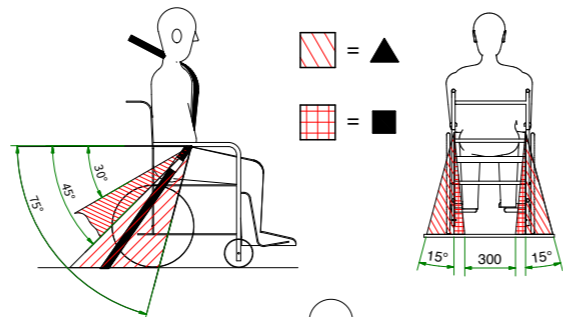

When using wheelchair with Dahl Docking system, the floor anchorage points for occupant restraint should be located 10-60mm outside wheels, on each side.

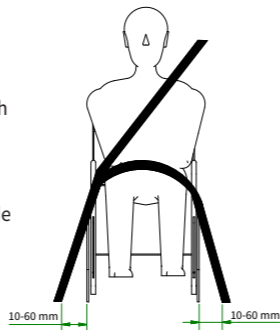

Recommended location of shoulder belt's top anchoring point:

▲ = Preferred Zone  
 ■ = Optional Zone

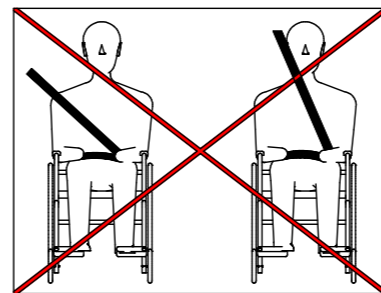
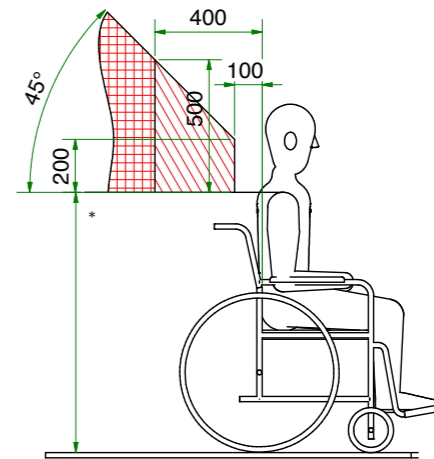
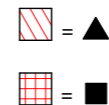

The lap belt should make full contact with the front of the body in the area where the pelvis and thighbone meet.

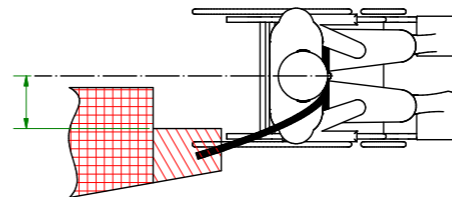

\*= Installation height from the floor and up to the shoulder and the shoulder belt's top anchoring point depends on the height of both the user and the wheelchair. The shoulder belt's anchoring point must be located in such a manner, that the belt runs over the midpoint of the shoulder.

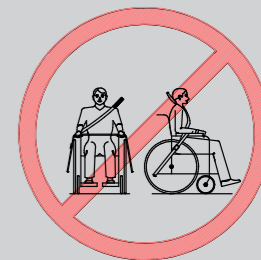

Safety belts must not be held away from the body by wheelchair components or parts such as armrests or wheels.

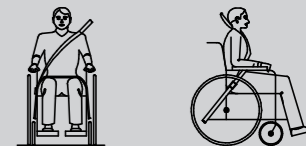

## Installation of safety belts

Please also refer to separate installation instructions for the safety belt concerned. We have safety belt anchorage kits available that have been tested in accordance with ECE regulation 14.

Please enquire about our current range of kits.



Seat belts must, as a general rule, ALWAYS be anchored in the vehicle floor, not on the wheelchair.

### WARNING! Risk of death or serious injury

The docking station and vehicle-specific anchorage kits are designed and tested on condition that the seat belt is anchored to the vehicle body and floor, not on the wheelchair.

In the event of a collision, a wheelchair with an integrated safety belt will expose the docking station and vehicle floor to a much higher torque / load than a wheelchair where the seat belt is anchored to the vehicle's body and floor.

Thus, there is a risk that the wheelchair user and other passengers in the vehicle can suffer severe or fatal injuries during a collision, as a result of the vehicle floor being deformed severely or the anchoring points of the docking station being torn loose. Therefore never use the docking station for anchoring a wheelchair with integrated seat belt anchor points, whether this is a 3-point belt, an H- or lap belt.

## Examples of seat belt components

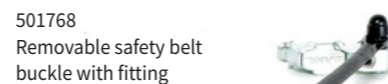

Safety belt buckles can be ordered in different lengths. Please ask about the current range.

## Examples of installation of retractor and bracket (D-loop) for anchoring of shoulder belt

Please see separate installation guide for mounting of anchorage kit for shoulder belt for each vehicle.

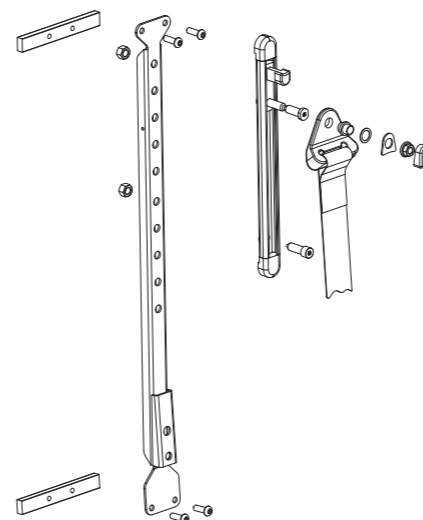

Example with 178 mm height adjustment  
Art. no. 500945.

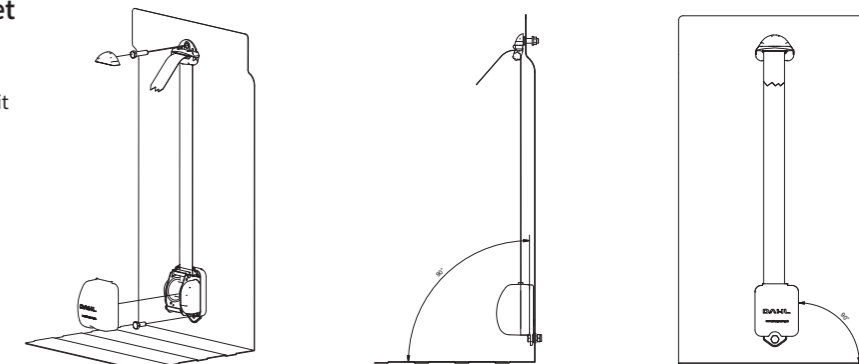

Example with the retractor installed on the wall.

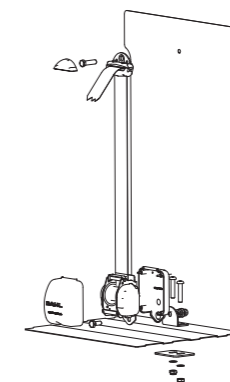

Example with the retractor installed in the vehicle floor.

Here, examples are shown of the proper orientation (90°/90°) of the D-loop and retractor for both floor and wall mounted retractors.

It must be possible to rotate the D-loop for the shoulder belt when the bolt is tightened.

## Installation of universal fitting in floor pocket and floor rail with airline hole pattern

Make sure that the floor pocket or floor rail is free of small stones or other dirt. If necessary, clean prior to installation of the universal fitting. If the floor pocket or the floor rail is not free of dirt, there is a risk that the fitting cannot be installed or that it will not be fitted correctly.

1. Place the universal fitting over the holes.
2. Press downwards on the universal fitting so that the spring-action locking bolt moves upwards. Whilst the fitting is being pressed downwards, push the fitting backwards or forwards until the spring-action locking bolt slides down into one of the holes.
3. A click should be heard when the locking bolt hits the bottom of the hole.

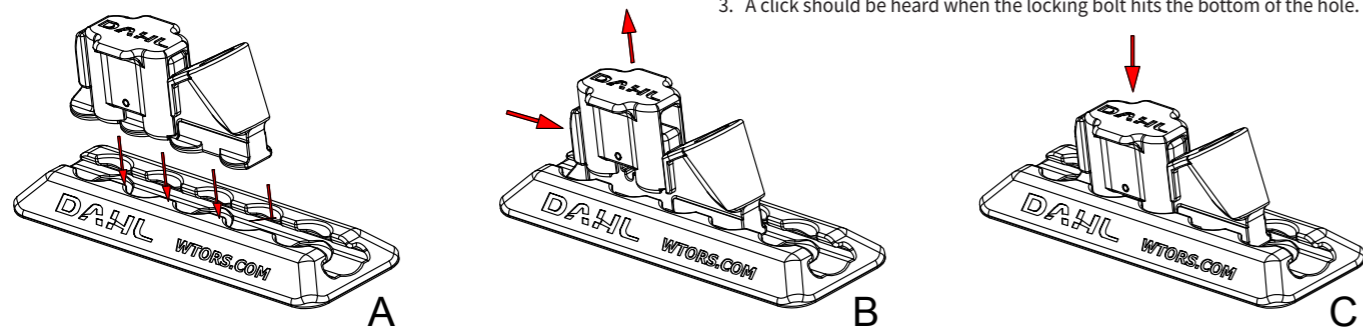

### Warning

In countries where legislation demands meeting EU-Regulation 2018/858, Annex II, Part III, Appendix 3 relating to vehicles fitted for wheelchairs, a fitting kit MUST be used, which has been tested in the position and the specific vehicle the wheelchair will be used in, for fitting the docking system and safety belts for the wheelchair user.

Please enquire with regard to the current range of vehicle specific fitting kits with corresponding fitting instructions.

If a vehicle specific fitting instruction exists, it must be requested from Dahl Engineering, and followed when fitting safety belts, floor pockets, floor rails and docking station.

The following fitting examples for fitting the Dahl VarioDock can only be used in countries where no legal requirements to tests of docking system in the specific vehicle and mounting position are to be found.

We always recommend using a fitting kit which has been tested in the specific vehicle and which meets EU regulation 2018/858.

## Installation examples of floor pocket

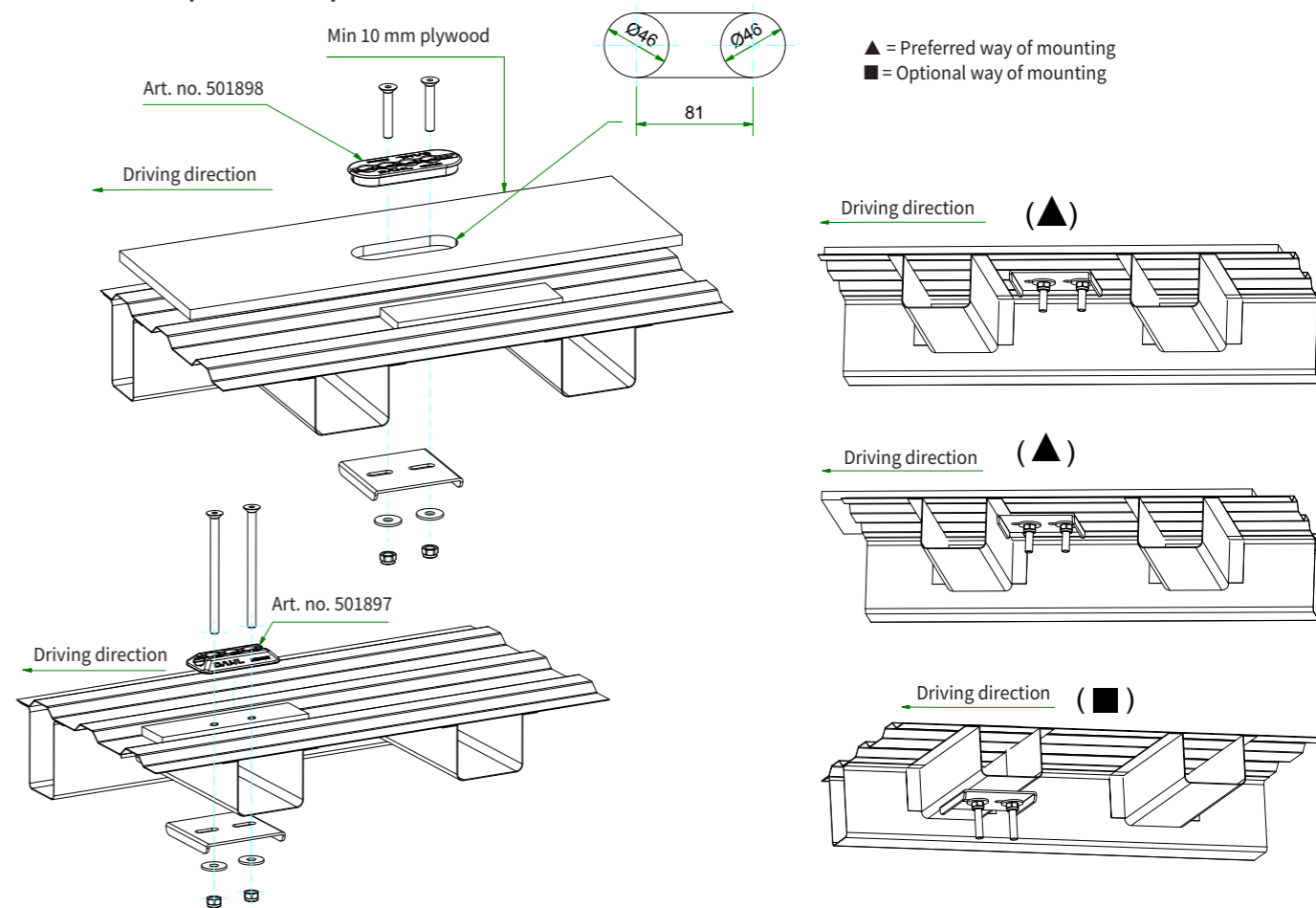

▲ = Preferred way of mounting  
■ = Optional way of mounting



## Spare parts list for VarioDock™

#503600

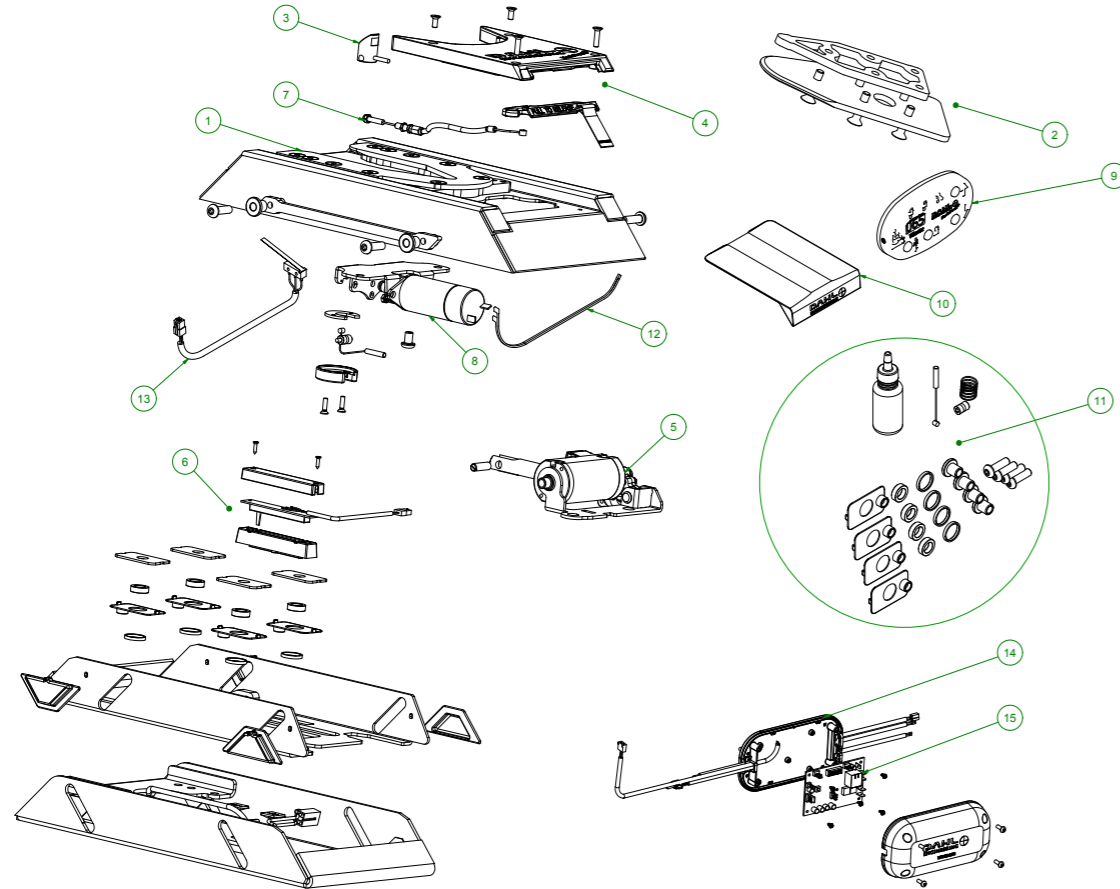

| No | Quantity | Art. no. | Description                                       |
|----|----------|----------|---|
| 1  | 1        | 503502C  | Top plate   |
| 2  | 1        | 503125   | Lock plate, complete                              |
| 3  | 1        | 503555   | Lock pin, complete                                |
| 4  | 1        | 502358   | Top cover, complete                               |
| 5  | 1        | 502357   | Motor, complete                                   |
| 6  | 1        | 503554   | Potentiometer, complete                           |
| 7  | 1        | 503519C  | Cable for quick release                           |
| 8  | 1        | 502350C  | Solenoid/Electromagnet                            |
| 9  | 1        | 503553C  | Control panel                                     |
| 10 | 1        | 503161   | Emergency Release Tool                            |
| 11 | 1        | 503636   | Service kit                                       |
| 12 | 1        | 503641   | Solenoid cable, internal                          |
| 13 | 1        | 503640   | Microswitch with wiring, external                 |
| 14 | 1        | 503700   | Control Box with wiring harness and PCB, complete |
| 15 | 1        | 503630   | Circuit Board (PCB), only                         |



# WHERE SAFETY STARTS



Development and crash-test centre  
Where safety starts

Dahl Engineering ApS | Løvevej 3 | DK-7700 Thisted | Danmark | Telefon: +45 9618 0077  
e: [sales@dahlengineering.dk](mailto:sales@dahlengineering.dk) | w: [wtors.com](http://wtors.com)