

Guide de conformité

– Produits et véhicules approuvés

FRANÇAIS



Sommaire

DAHL ENGINEERING APS	3
LE KIT D'ADAPTATION POUR VOTRE FAUTEUIL ROULANT	4
LISTE DES VÉHICULES	
– avec kits d'installation approuvés pour les systèmes d'arrimage Dahl.....	8
LISTE DE COMPATIBILITÉ	
– Ford Transit Custom V710/ VW New Transporter.....	10
DAHL VARIODOCK	11
– Kits d'installations certifiés.....	12
DAHL DOCKING STATION MK II	25
– Kits d'installations certifiés.....	26
LISTE DES VÉHICULES	
– avec kits d'installation approuvés pour FR/UFR 4 points	39
LISTE DE COMPATIBILITÉ	
– Ford Transit Custom V710/ VW New Transporter.....	42
LIGNE CLASSIC	43
– Kits d'installations certifiés.....	44
LIGNE EVOLUTION	50
– Kits d'installations certifiés.....	51
LIGNE HEAVY DUTY	64
– Kits d'installations certifiés.....	65
SIÈGE CONFORT	71
– Kits d'installations certifiés.....	72
Fiche de liaison	77
Conditions de vente et de livraison	79



Dahl Engineering est riche de plus de 30 ans d'expérience dans le développement, les essais de sécurité et la production d'équipements automobiles. Cette expertise nous confère une connaissance approfondie en matière de sécurité et d'exigences légales.

Conformément au règlement (UE) 2018/858, tous les WTORS (systèmes d'arrimage des fauteuils roulants et de retenue des occupants) doivent être testés dans le modèle de véhicule et à la position d'installation spécifiques où l'équipement est utilisé.

Nous proposons des kits d'installation complets, approuvés par le TÜV Rheinland, pour les systèmes à 4 points et les systèmes d'amarrage. Ces solutions respectent – et dépassent – les exigences du règlement européen 2018/858, afin de sécuriser les fauteuils roulants pesant entre 85 kg et 200 kg, en plus du poids de l'utilisateur.

Notre guide de conformité offre une vue d'ensemble détaillée de toutes les solutions testées et approuvées, spécifiques à chaque véhicule. Nous avons testé et validé nos systèmes d'arrimage, nos WTORS à 4 points ainsi que nos sièges COMFORT, conformément aux réglementations et normes en vigueur.

Cette publication vous fournit une présentation claire et synthétique, permettant d'identifier rapidement le numéro de pièce approprié en fonction du modèle de véhicule et de la position d'installation. Les différentes positions d'installation dans le véhicule peuvent être repérées grâce au schéma du véhicule, qui indique l'emplacement des solutions testées.

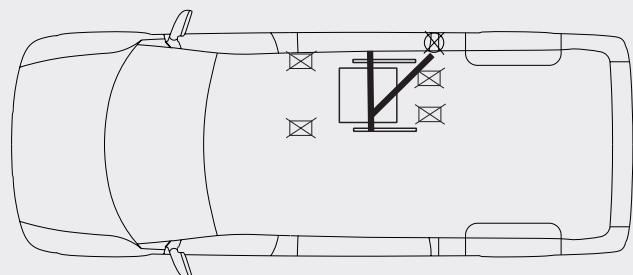

le Kit d'adaptation pour votre fauteuil roulant

Fauteuils roulants agréés avec nos systèmes d'arrimage

En vertu des directives médicales de l'UE, un fauteuil roulant est classé comme équipement médical de la classe 1, et doit porter la marque CE et être approuvé en tant que tel. Quiconque installe ou adapte un équipement non agréé ou installe le système d'une façon qui ne respecte pas les spécifications du fabricant du fauteuil roulant, enfreint l'agrément CE et est considéré fabricant responsable, et dès lors responsable de la qualité, de la sécurité, du fonctionnement et de la documentation technique en vertu des exigences de la réglementation sur l'équipement médical.

Si nos systèmes d'arrimage sont installés sur un fauteuil roulant qui a été testé et approuvé par le fabricant du fauteuil, l'agrément CE reste en vigueur. Il est fortement conseillé que les instructions stipulées dans le manuel du fabricant du fauteuil roulant soient scrupuleusement respectées.

Des vidéos de crash-tests, ainsi que les manuels d'usage et d'entretien des fabricants des fauteuils roulants peuvent être consultés sur le site.

Veillez contacter le fabricant du fauteuil roulant pour l'équipement approuvé et la garde au sol pour assurer la compatibilité avec nos systèmes d'arrimage Dahl.

MARQUE ET MODÈLE Fauteuil roulant électrique	Montage standard possible de la semelle de verrouillage sur le fauteuil roulant	Kit Dahl Engineering disponible pour une adaptation en rétrofit	Kit fabricant de fauteuil disponible pour une adaptation en rétrofit	Adaptation NON disponible en rétrofit. Option usine possible uniquement à la commande du fauteuil roulant	Compatible avec VarioDock
Baldertech F380 (280) Finesse tiltstol			Balder#HP20071413		✓
Baldertech F380 Recaro Finesse tiltstol			Balder#HP20071413		✓
Baldertech F390 (290) Finesse ståstol			Balder#HP20071413		✓
Baldertech J335 (235) Junior tiltstol			Balder#HP20071413		✓
Baldertech J340 (240) Junior ståstol			Balder#HP20071413		✓
Baldertech Liberty RWD			Balder#HP20071413		✓
Degonda T4 2x2		#503213			✓
Degonda T4 Compact		#503213			✓
Dietz Power Sango Advanced FWD SEGO			Dietz#5001168		✓
Dietz Power Sango Advanced MWD SEGO			Dietz#5001168		✓
Dietz Power Sango Advanced RWD SEGO			Dietz#5001168		✓
Dietz Power Sango Slimline FWD SEGO			Dietz#5001169		✓
Dietz Power Sango Slimline MWD SEGO			Dietz#5001169		✓
Dietz Power Sango Slimline RWD SEGO			Dietz#5001169		✓
Freedom One Life Series 5 (fra 2023-2025)			✓**		✓
Freedom One Life Series 5 (fra 2026)	✓				✓
Glide CentroGlide		#502237			✓
Glide Centro 2.0		#502237			✓
Invacare AVIVA RX				Invacare #SP1653422	✓
Invacare FX 40 Modulite		#501540			✓
Invacare Storm4				#ATZ1450	✓
Invacare Storm4 Xplore				#ATF1450	✓
Invacare TDX SP2 (WB)				#SP1564843	✓
Invacare TDX SP2 (NB)				#SP1564807	✗
Invacare TDX SP2 MBL Tilt-Lifter (WB)				#SP1564843	✓
Invacare TDX SP2 MBL Tilt-Lifter (NB)				#SP1564807	✗
Karma EVO Altus / Lectus-LR		#503194			✓
Karma Leon FWD Kameleon			Karma#191700000061		✓
Karma Leon FWD Versus			Karma#191700000061		✓
Karma Leon RWD			Karma#151200000023		✓
Karma Mid Lectus		#503339			✓
Karma Morgan			Karma#4020169		✓

le Kit d'adaptation pour votre fauteuil roulant

MARQUE ET MODÈLE Fauteuil roulant électrique	Montage standard possible de la semelle de verrouillage sur le fauteuil roulant	Kit Dahl Engineering disponible pour une adaptation en rétrofit	Kit fabricant de fauteuil disponible pour une adaptation en rétrofit	Adaptation NON disponible en rétrofit. Option usine possible uniquement à la commande du fauteuil roulant	Compatible avec VarioDock
Karma Morgan M Lectus		#503339			✓
Karma Morgan M Versus		#503339			✓
Karma Morgan Sling		#503339			✓
LEVO LCM 2		#502322			✓
LEVO C3 Standup		#503030			✓
Magic Mobility 360		#501798			✓
Medema MC 1122	✓				✓
Medema MC 1124 Adult		#502378			✓
Medema MC 1124 Child		#502378			✓
Medema MC 1144 Adult		#503236			✓
Medema MC 1144 Child		#503236			✓
Meyra iChair MC2 1.611		#501909			✓
Meyra iChair MC2 1.611 / Electrical backrest		#503453			✓
Meyra iChair MC3 1.612			Meyra#1079816		✓
Meyra iChair McFront 1.613		#501619			✓
Meyra iChair McFront 1.613 / Electrical backrest		#501620			✓
Meyra iChair Orbit 1.618		#503657			✓
Meyra iChair Meylife 1.650		#503657			✓
Neatech EVO 1		#503340			✓
Neatech EVO 3		#502210			✓
New Live Magix			NewLive MA.O.P.01. AC.Z.800003		✓
New Live Magix II	✓*				✓
NHD LS 300		#503341			✓
NHD LS300/45		#503341			✓
Otto Bock Juvo B4 RWD		#503184			✓
Otto Bock Juvo B5/B6 FWD		#503261			✓
Otto Bock Juvo B5/B6 MWD		#503261			✓
Otto Bock Juvo B5/B6 RWD		#503261			✓
Otto Bock Juvo B7 MWD		#503261			✓
Paravan Heavy Duty			Paravan#33187		✓
Paravan PR 25		#502064			✓
Paravan PR 35S		#502064			✓
Paravan PR 40		#502064			✓
Paravan PR 50			Paravan#33187		X
Paravan Piccolino			Paravan#33187		✓
Permobil F3 Corpus	✓*				✓
Permobil F5 Corpus	✓*				✓
Permobil F5 Corpus VS	✓*				✓
Permobil M1	✓*				✓
Permobil M3 Corpus	✓*				✓
Permobil M5 Corpus	✓*				✓
Permobil M5 Corpus VS	✓*				✓
Quantum Rehab (Pride Mobility), Q6 Edge 2.0*		#502378			✓
Quantum Rehab (Pride Mobility), Q6 Edge 3.0*		#502378			✓
Rehamed Power RP1		#502917			✓
Roltec Boa 2		#503342			✓
Roltec Moveo		#501819			✓

* Concernant la disponibilité, veuillez-vous renseigner auprès de l'importateur Pride/quantum de votre pays.

le Kit d'adaptation pour votre fauteuil roulant

MARQUE ET MODÈLE Fauteuil roulant électrique	Montage standard possible de la semelle de verrouillage sur le fauteuil roulant	Kit Dahl Engineering disponible pour une adaptation en rétrofit	Kit fabricant de fauteuil disponible pour une adaptation en rétrofit	Adaptation NON disponible en rétrofit. Option usine possible uniquement à la commande du fauteuil roulant	Compatible avec VarioDock
Roltec Viper			Roltec#70658		✓
Roltec CT4 RWD / Vision			Roltec#70658		✓
Scout Mobility X10 FWD		#503366			✓
Scout Mobility X10 MWD		#503366			✓
Scout Mobility X10 RWD		#503366			✓
SKS Swiss Viva Grand			SKS#22.0218		✓
SKS Swiss Viva Grand M		#503342			✓
Sunrise Medical Q100 R		#503259			✓
Sunrise Medical Q200 R		#503259			✓
Sunrise Medical Q300M Mini		#500094			✗
Sunrise Medical Q300 R		#503012			✓
Sunrise Medical Q400 F		#503637			✓
Sunrise Medical Q400 M		#503439			✗
Sunrise Medical Q400 R		#503637			✓
Sunrise Medical Q500 F		#503637			✓
Sunrise Medical Q500 H		# 501798			✓
Sunrise Medical Q500 M		#503439			✗
Sunrise Medical Q500 R		#503637			✓
Sunrise Medical Q700 F		#501889			✓
Sunrise Medical Q700 M		#503439			✓
Sunrise Medical Q700 R		#503637			✓
Sunrise Medical Q700 UP F		#501889			✓
Sunrise Medical Q700 UP M		#503439			✓
Sunrise Medical QUICKIE Salsa M2		#501798			✗
Sunrise Medical QUICKIE Salsa R2		#501756			✓
TA Service IQ RWD		#503054			✓
TA Service IQ FWD		#503054			✓
TA Service IQ MWD		#503054			✓
TA Service Indoor Wave			TA #95255		✓
Wolturnus A-Run				Wolturnus #20778	✓
Wolturnus Rex 350				Wolturnus #20779	✓

MARQUE ET MODÈLE Fauteuil roulant manuel	Système MADS amovible	Kit Dahl Engineering disponible pour une adaptation en rétrofit	Kit fabricant de fauteuil disponible pour une adaptation en rétrofit	Adaptation NON disponible en rétrofit. Option usine possible uniquement à la commande du fauteuil roulant	Compatible avec VarioDock
Hoggi Swingbo VTi/XL	✓	#503044			✓
Neatech LB	✓	#504120			✓
R82 Kudu	✓	#503026			✓
Schmicking X-Design	✓	#502898			✓
Sunrise Medical Exigo 30	✓	#502961			✓
Talart JT-Sparkle	✗		Talart #JT01154		✓
Wolturnus W5	✓	#502018			✓
Wolturnus W5	✗			#20776 / #20777	✓

Tous les fauteuils roulants retirés de production, mais approuvés et testés, peuvent être trouvés sur notre page d'accueil.

Systemes d'arrimage Dahl - kits d'installations certifies

Marque de vehicule	Modele de vehicule	Position de l'ancrage de la ceinture epauliere	Type de montage sur plancher	MK II	Vario	Premiere rangee de sieges			FMVSS 207/ CMVSS 207	FMVSS 210/ CMVSS 210	
						Nombre de station d'arrimage	Console de siege	Ancrage epauliere			
Citroën	Berlingo, Tripod/allied dropfloor conversion	B	/	503461	503954	2	1	1			
	Jumper Y	C	surface	502171	503920						
		C	flush	502172	503921						
		W	surface	502179	503928						
		W	flush	502180	503929						
	Jumpy X	C	surface	502171	503920						
		C	flush	502172	503921						
		RD	surface	502177	503926						
		RD	flush	502178	503927						
	Jumpy & Spacetourer KO	B			503303	503950	1	0	1		
		B			503304	503951	1	0	1		
		B			503305	503952	2	1	0		
B				503306	503953	2	1	2			
C		surface		503302	503949						
C		flush		503301	503946						
Fiat	Doblo high roof SWB & LWB	D	surface	503121	503940						
		D	flush	503120	503939						
	Ducato X250	C	surface	502171	503920						
		C	flush	502172	503921						
		W	surface	502179	503928						
		W	flush	502180	503929						
	Scudo X270	C	surface	502171	503920						
		C	flush	502172	503921						
		RD	surface	502177	503926						
		RD	flush	502178	503927						
	Talento 2016-	C	surface	502171	503920						
		C	flush	502172	503921						
D		surface	502171	503920							
D		flush	502172	503921							
Ford	Transit Custom V362	C	surface	502171	503920						
		C	flush	502172	503921						
		RD	surface	502177	503926						
		RD	flush	502178	503927						
	Transit V363	C	surface	502194	503932						
	Transit Custom V710	VOIR LA LISTE À LA PAGE 10 POUR PLUS D'INFORMATIONS.									
Jeep	Renegade, ACA Drop floor conversion	B		501551	501552	2	1	0			
MAN	TGE 2017-	C	surface	503142	503941						
		C	flush	503143	503942						
		W	surface	503145	503944						
		W	flush	503144	503943						
		D	surface	502171	503920						
		D	flush	502172	503921						
Mercedes	Vito & V-Class W447	B		502163	503914	2	1	2			
		B		502164	503915	2	1	0			
		B		502165	503916	1	0	1			
		B		502166	503917	1	0	1			
		B		502167	503918	1	0	0			
		B		502168	503919	1	0	0			
		C	surface	502171	503920						
		C	flush	502172	503921						
		RD	surface	502177	503926						
		RD	flush	502178	503927						
		W	surface	503008	503007						
		W	flush	503006	503005						
	Sprinter 906 & 907 & 910	B			501970	503902	2	1	2	√	√
		B			501971	503903	1	0	1	√	√
		B			502034	503905	2	1	0	√	√
		B			502035	503906	1	0	0	√	√
		W	surface		502175	503924				-	√
		W	flush		502176	503925				-	√
Sprinter 907/910 (IKKE 906)	D	surface		502171	503920				-	-	
	D	flush		502172	503921				-	-	
	C	flush		504169	504168				-	√	
	C*	flush		504167	504166				-	√	
	Mitsubishi	Express (Australien & New Zealand)	C	surface	502171	503920					
			C	flush	502172	503921					
D			surface	502171	503920						
D			flush	502172	503921						
Nissan	Interstar 2024	C	flush	504162	504163				-	√	
		D	flush	504157	504159				-	√	
	NV 200	W	surface		503197	503945					
		C	surface		502171	503920					
		C	flush		502172	503921					
		D	surface		502171	503920					
	NV 400	D	flush		502172	503921					
		B			502039	503909	2	1	2		
		B			502041	503911	2	1	0		
		B			502042	503912	1	0	1		
		B			502043	503913	1	0	0		
		C	surface		502181	503930					
Primastar	C	flush		502182	503931						
	C	surface		502171	503920						
	C	flush		502172	503921						
	D	surface		502171	503920						
	D	flush		502172	503921						
	Opel	Combo High roof SWB & LWB	D	surface	503121	503940					
D			flush	503120	503939						

* Porte coulissante

Systemes d'arrimage Dahl - kits d'installations certifies

Marque de vehicule	Modele de vehicule	Position de l'ancrage de la ceinture epauliere	Type de montage sur plancher	MK II	Vario	Premiere rangee de sieges			FMVSS 207/ CMVSS 207	FMVSS 210/ CMVSS 210	
						Nombre de station d'arrimage	Console de siege	Ancrage epauliere			
	Movano X 62	B		502039	503909	2	1	2			
		B		502041	503911	2	1	0			
			B		502042	503912	1	0	1		
			B		502043	503913	1	0	0		
			C	surface	502181	503930					
			C	flush	502182	503931					
	Vivaro X 82 & X 83		C	surface	502171	503920					
			C	flush	502172	503921					
			D	surface	502171	503920					
			D	flush	502172	503921					
	Zafira Life		C	surface	503302	503949					
			C	flush	503301	503946					
		B		503303	503950	1	0	0			
		B		503304	503951	1	0	1			
		B		503305	503952	2	1	0			
Peugeot	Boxer Y	B		503306	503953	2	1	2			
		C	surface	502171	503920						
		C	flush	502172	503921						
			W	surface	502179	503928					
			W	flush	502180	503929					
	Expert X		C	surface	502171	503920					
			C	flush	502172	503921					
			W	surface	502177	503926					
			W	flush	502178	503927					
	Expert & Traveller KO		C	surface	503302	503949					
			C	flush	503301	503946					
			B		503303	503950	1	0	0		
		B		503304	503951	1	0	1			
		B		503305	503952	2	1	0			
		B		503306	503953	2	1	2			
	Partner, Tripod/Allied drop floor conversion	B		503461	503954	2	1	2			
Renault	Master X62	B		502039	503909	2	1	2			
		B		502041	503911	2	1	0			
			B		502042	503912	1	0	1		
			B		502043	503913	1	0	0		
			C	surface	502181	503930					
			C	flush	502182	503931					
	Trafic X82 & X83		C	surface	502171	503920					
			C	flush	502172	503921					
			D	surface	502171	503920					
			D	flush	502172	503921					
	Master XDD 2024-		C	flush	504162	504163				-	√
			D	flush	504157	504159				-	√
Toyota	Proace	C	surface	502171	503920						
		C	flush	502172	503921						
		RD	surface	502177	503926						
			RD	flush	502178	503927					
	Proace & Proace Verso 2017-		C	surface	503302	503949					
			C	flush	503301	503946					
		B		503303	503950	1	0	0			
VW	Caddy, ITEK drop floor conversion	B		503304	503951	1	0	1			
		B		503305	503952	2	1	0			
		B		503306	503953	2	1	2			
				503255	503947	2	1	2			
				503310	503948	2	1	0			
				501970	503902	2	1	2	√	√	
	Crafter (2006-2016)		B		501971	503903	1	0	1	√	√
			B		502034	503905	2	1	0	√	√
			B		502035	503906	1	0	0	√	√
			W	surface	502175	503924				-	√
			W	flush	502176	503925				-	√
			D	surface	502171	503920				-	√
		D	flush	502172	503921						
Crafter 2017 -			C	surface	503142	503941					
			C	flush	503143	503942					
			W	surface	503145	503944					
		W	flush	503144	503943						
		D	surface	502171	503920						
		D	flush	502172	503921						
VW T5 & T6		B		501973	503904	1	0	1			
		B		502036	503907	1	0	0			
		B		502037	503908	2	1	0			
		B		502040	503910	2	1	2			
		C	surface	502171	503920						
		C	flush	502172	503921						
		W	surface	502173	503922						
		W	flush	502174	503923						
		RD	surface	502177	503926						
		RD	flush	502178	503927						
		New Transporter/Caravelle 2025-T6, Zawatzky Centervan, Drop floor conversion	VOIR LA LISTE A LA PAGE 10 POUR PLUS D'INFORMATIONS.								
			B		502368	503937	2	1	2		
		B		502369	503938	2	1	0			
T5 & T6 Colorado, GM Coachwork, Drop floor conversion		B		502285	503933	2	1	2			
		B		502286	503934	1	0	1			
		B		502287	503935	2	1	0			
		B		502288	503936	1	0	0			

Symboler: Pied de caisse milieu = C / Pied de caisse arriere = D / Encadrement vitre = W / Porte arriere = RD / Ancrage plot de surface = surface / Ancrage en insertion = flush / Rail de plancher = rail

Liste de compatibilité

Position de l'épaule ancrage de la ceinture	Trappe de plancher type	N° d'article du kit d'arrimage MK II	Type de propulsion Compatibilité			Dimensions de la camionnette Compatibilité				Style de carrosserie Compatibilité			FMVSS/CMVSS 207	FMVSS/CMVSS 210
			BEV*	PHEV*	ICE*	L1	L2	H1	H2	Van	Kombi	Bus		
rangée de sièges 1		504144	✓	✓	✓	✓	✓	✓	✓	✓	✓	✓	✓	✓
		504149	✓	✓	✓	✓	✓	✓	✓	✓	✓	✓	✓	✓
rangée de sièges 2, cadre de la vitre latérale arrière	surface													
	flush	500221	✓	✓	✓	✓	✓	✓	✓	✓	✓	✓	-	✓
		504063	-	-	✓	✓	✓	✓	✓	✓	✓	✓	✓	✓
rangée de sièges 3, Montant D	surface													
	flush	500253	✓	✓	✓	✓	✓	✓	✓	-	✓	✓	-	✓
rangée de sièges 3, ouverture supérieure de la porte arrière	surface													
	flush	500254	✓	✓	✓	✓	✓	✓	-	-	✓	✓	-	✓

Position de l'épaule ancrage de la ceinture	Trappe de plancher type	N° d'article du kit d'arrimage VarioDock	Type de propulsion Compatibilité			Dimensions de la camionnette Compatibilité				Style de carrosserie Compatibilité			FMVSS/CMVSS 207	FMVSS/CMVSS 210
			BEV*	PHEV*	ICE*	L1	L2	H1	H2	Van	Kombi	Bus		
rangée de sièges 1		504148	✓	✓	✓	✓	✓	✓	✓	✓	✓	✓	✓	✓
		504150	✓	✓	✓	✓	✓	✓	✓	✓	✓	✓	✓	✓
rangée de sièges 2, cadre de la vitre latérale arrière	surface													
	flush	500222	✓	✓	✓	✓	✓	✓	✓	✓	✓	✓	-	✓
		504064	-	-	✓	✓	✓	✓	✓	✓	✓	✓	✓	✓
rangée de sièges 3, Montant D	surface													
	flush	500255	✓	✓	✓	✓	✓	✓	✓	-	✓	✓	-	✓
rangée de sièges 3, ouverture supérieure de la porte arrière	surface													
	flush	500256	✓	✓	✓	✓	✓	✓	-	-	✓	✓	-	✓

* BEV = Battery Electric Vehicle

* PHEV = Plug-In Hybrid Electric Vehicle

* ICE = Internal Combustion Engine

Consultez également les schémas des véhicules dans le chapitre suivant.

Dahl Engineering établit de nouvelles références en matière de flexibilité et de sécurité !

Notre nouvelle station VarioDock™ Dahl est non seulement, la seule station d'arrimage à hauteur réglable pour fauteuil roulant qui permet de simplifier la fixation des fauteuils roulants dont la garde au sol peut être variable, tout comme les sièges passagers de véhicules qui sont équipés d'une ceinture 3 points intégrée, mais c'est également le seul système de retenue à respecter les normes ISO 10542-1, ISO 7176-19 et M1 (relatives aux essais à bord des véhicules) pour les sièges et les ancrages de ceinture de sécurité, conformément aux réglementations UN 14.07 et 17.08 applicables dans la CEE.

Grâce au système de retenue VarioDock™ Dahl, assurant aux utilisateurs de fauteuil roulant ainsi qu'aux autres occupants assis dans le véhicule une sécurité optimum, la rapide mise en oeuvre se fait avec une facilité et une sécurité sans précédent. Le système d'arrimage VarioDock™ Dahl offre à ce jour la meilleure modularité par rapport aux systèmes d'ancrage de sièges existants, car le fauteuil roulant et le siège peuvent être intervenus très facilement, et ce, avec un minimum d'effort et de temps.

Par ailleurs, un système d'arrimage améliore considérablement les conditions de travail des conducteurs, qui souvent ont des difficultés à

oeuvrer dans des espaces saturés ce qui génère de mauvaises positions de travail lors de la sécurisation des fauteuils roulants avec des systèmes de retenue par sangles 4 points.

- Réglage motorisé de la hauteur allant de 61 à 91 mm.
- Temps d'arrimage réduit des $\frac{3}{4}$, par rapport au système de sangles rétractables 4P sur fauteuil roulant.
- Testé pour les fauteuils roulants pesant jusqu'à 200 kg, plus l'utilisateur.
- Homologué pour l'ancrage du siège COMFORT Dahl.
- Système motorisé de tension en 4 étapes pour éliminer les jeux indésirables.
- Temps de déverrouillage sélectionnable par intervalles de 5 ou 8 secondes.
- Information de maintenance nécessaire sur écran.
- Amélioration des conditions de travail des conducteurs.
- Pas de sangles sur le plancher à enjamber.
- Crash testé, et marquage CE avec environ 160+ fauteuils roulants.



Kits d'installation pour la station d'arrimage VarioDock™ Dahl uniquement pour les fauteuils roulants

Art. No. 501552

ACA Drop Floor Conversion:

Jeep Renegade

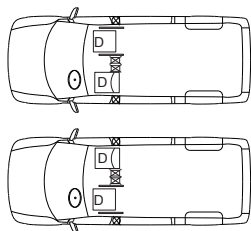
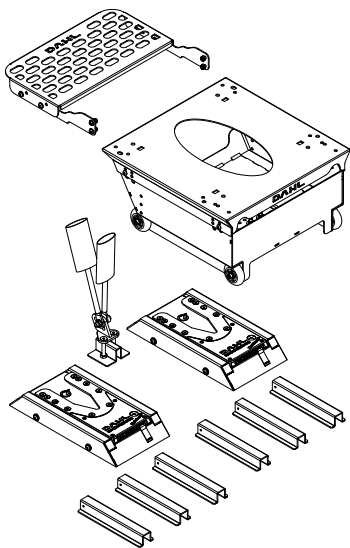

Art. No. 503902

MB Sprinter 906, 907 & 910

VW Crafter (2006-2016)

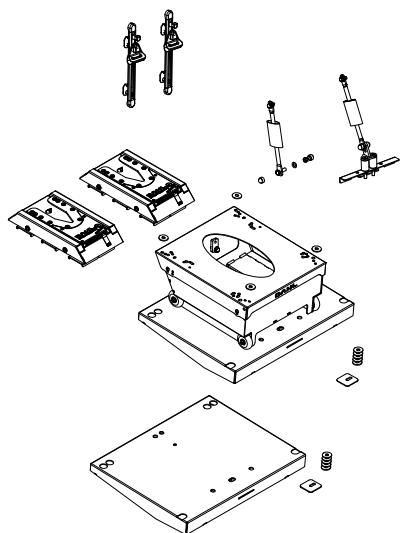

FMVSS/CMVSS
207/210

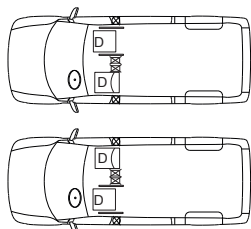

Art. No. 503903

MB Sprinter 906, 907 & 910

VW Crafter (2006-2016)

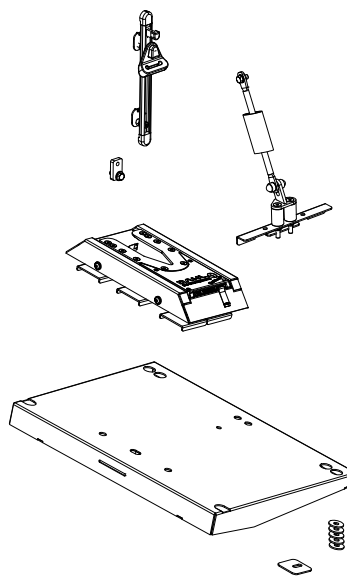

FMVSS/CMVSS
207/210

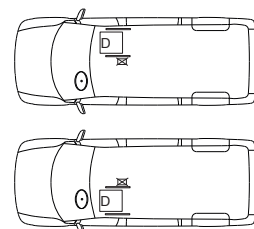

Art. No. 503904

VW T5 & T6

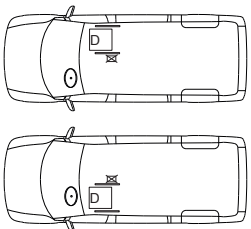
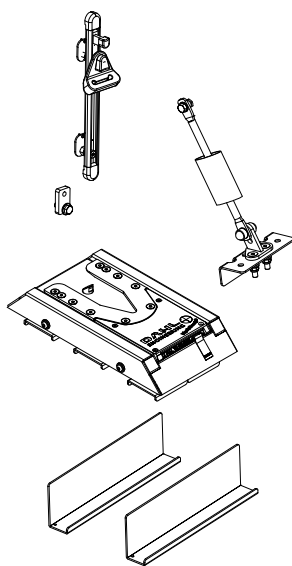

Art. No. 503905

MB Sprinter 906, 907 & 910

VW Crafter (2006-2016)

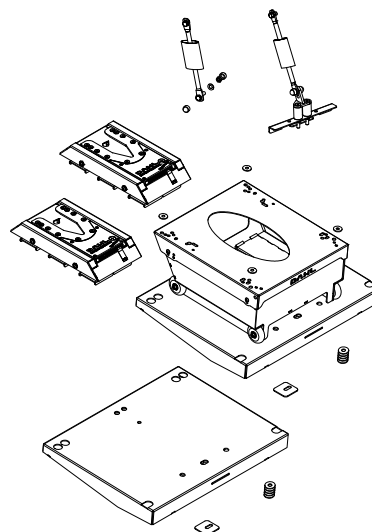

FMVSS/CMVSS
207/210

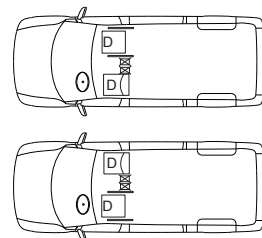

Kits d'installation pour la station d'arrimage VarioDock™ Dahl uniquement pour les fauteuils roulants

Art. No. 503906

MB Sprinter 906, 907 & 910
VW Crafter (2006-2016)

FMVSS/CMVSS
207/210

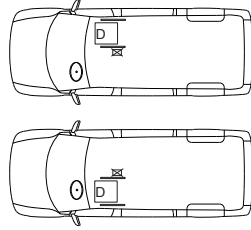
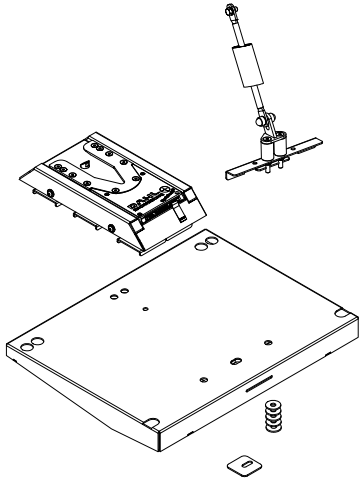

Art. No. 503907

VW T5 & T6

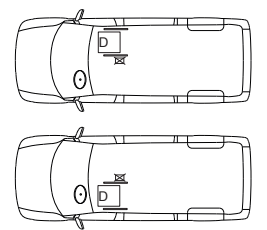
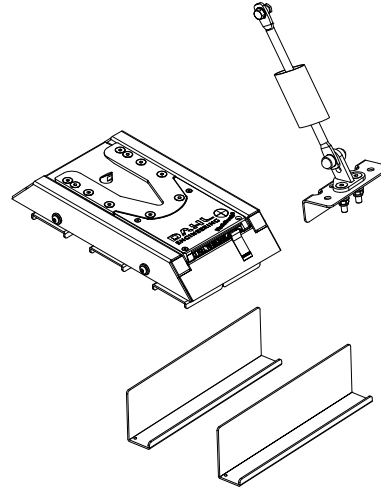

Art. No. 503908

VW T5 & T6

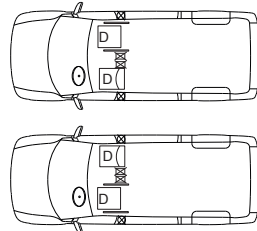
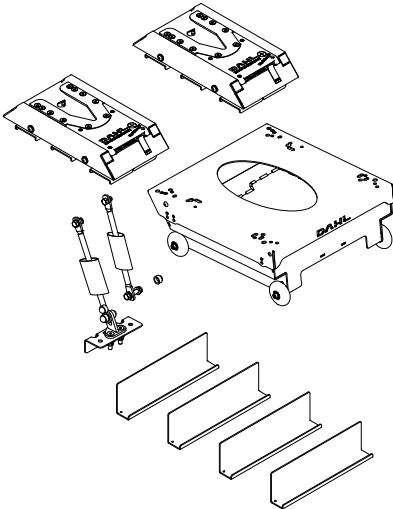

Art. No. 503909

Renault Master X62
Opel Movano X62
Nissan NV400

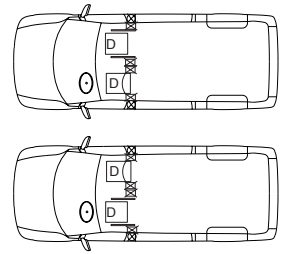
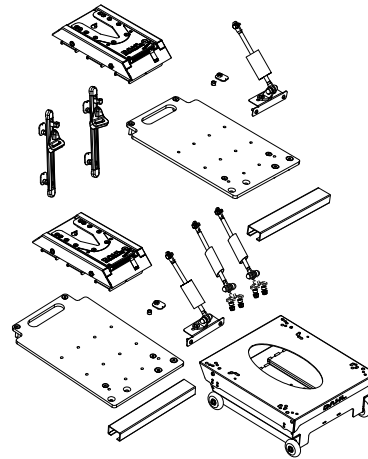

Art. No. 503910

VW T5 & T6

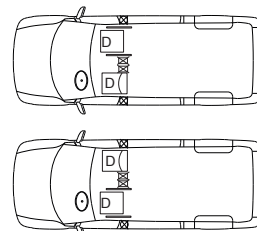
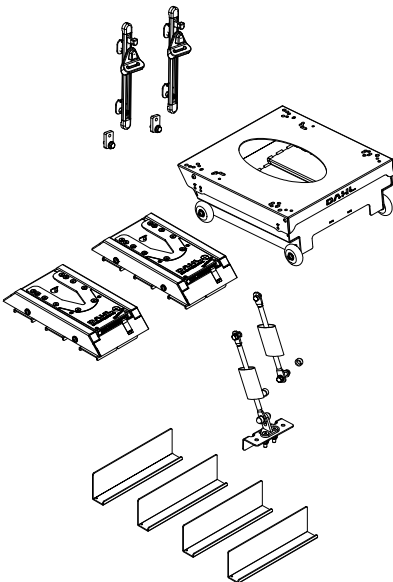

Art. No. 503911

Renault Master X62
Opel Movano X62
Nissan NV400

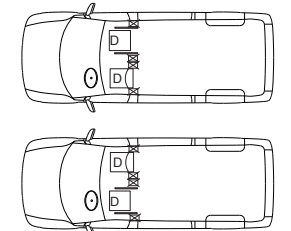
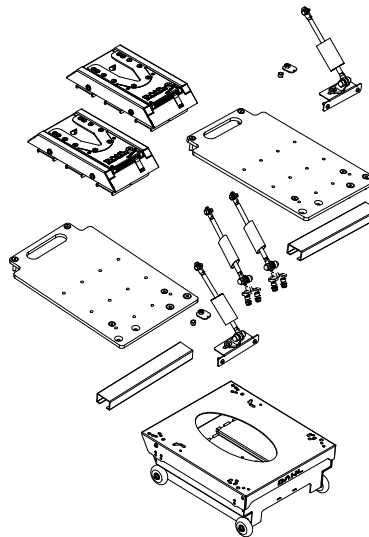

Kits d'installation pour la station d'arrimage VarioDock™ Dahl uniquement pour les fauteuils roulants

Art. No. 503912

Renault Master X62
Opel Movano X62
Nissan NV400

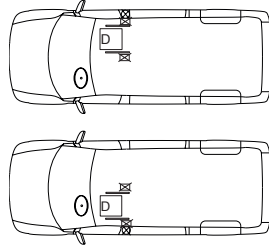
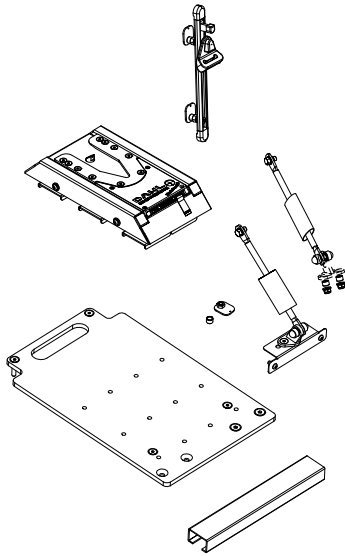

Art. No. 503913

Renault Master X62
Opel Movano X62
Nissan NV400

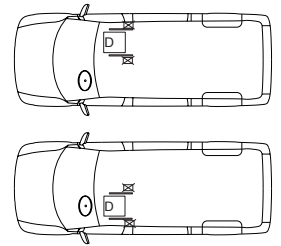
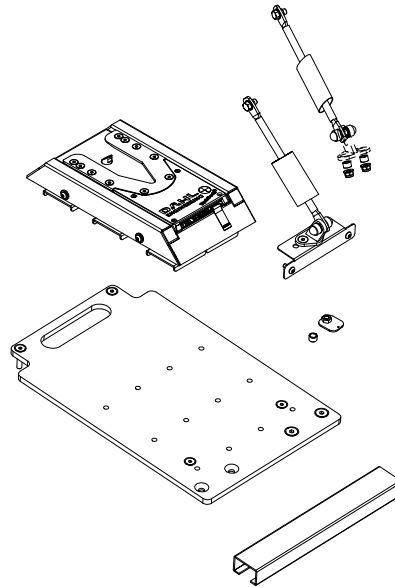

Art. No. 503914

MB Vito & V-Class W447

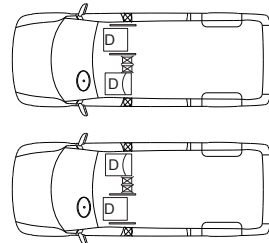
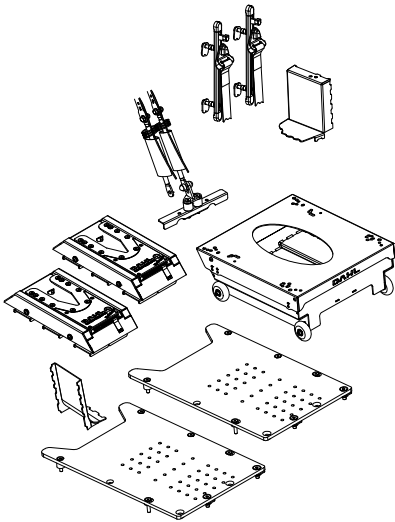

Art. No. 503915

MB Vito & V-Class W447

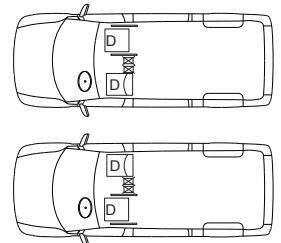
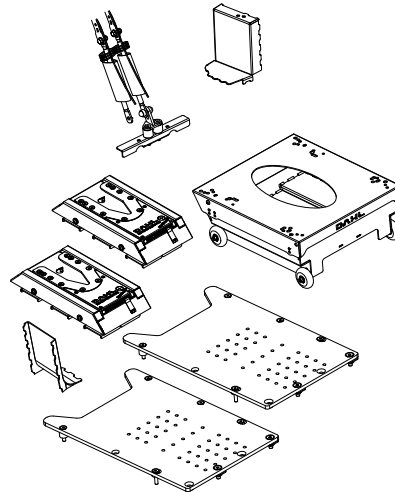

Art. No. 503916

MB Vito & V-Class W447

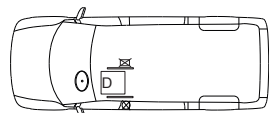
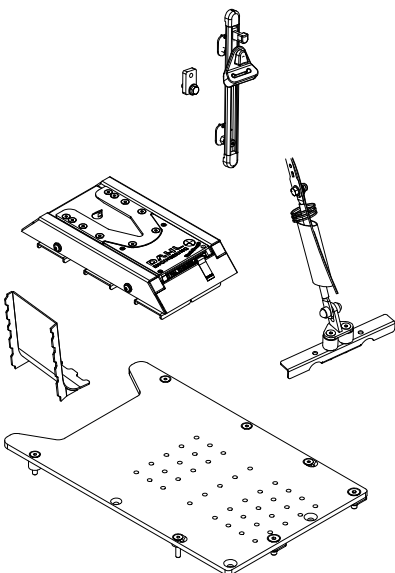

Art. No. 503917

MB Vito & V-Class W447

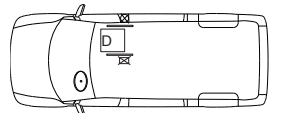
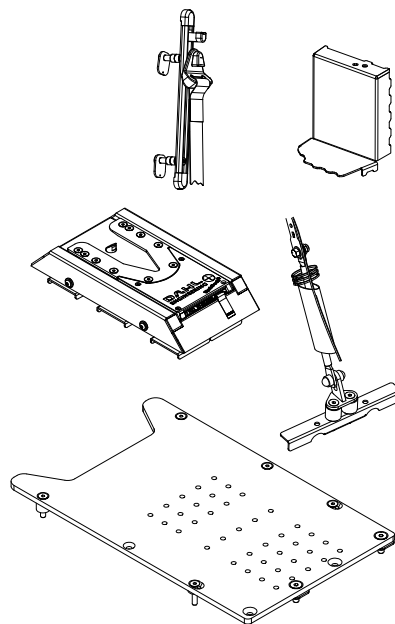

Kits d'installation pour la station d'arrimage VarioDock™ Dahl uniquement pour les fauteuils roulants

Art. No. 503918

MB Vito & V-Class W447

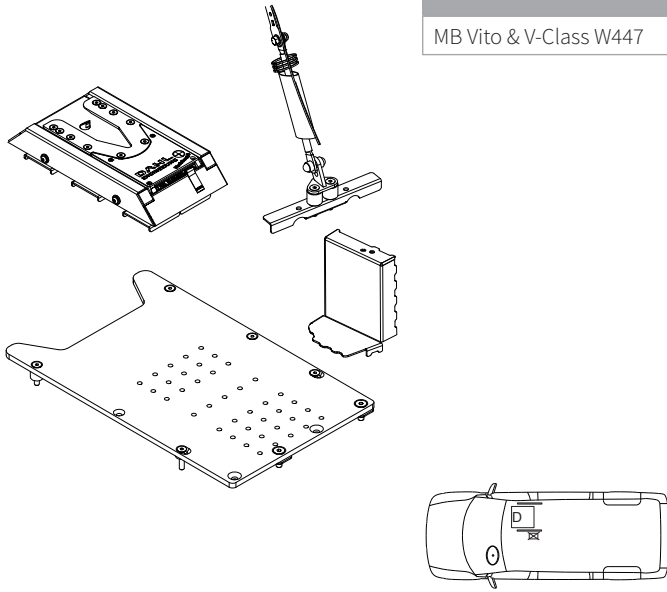

Art. No. 503919

MB Vito & V-Class W447

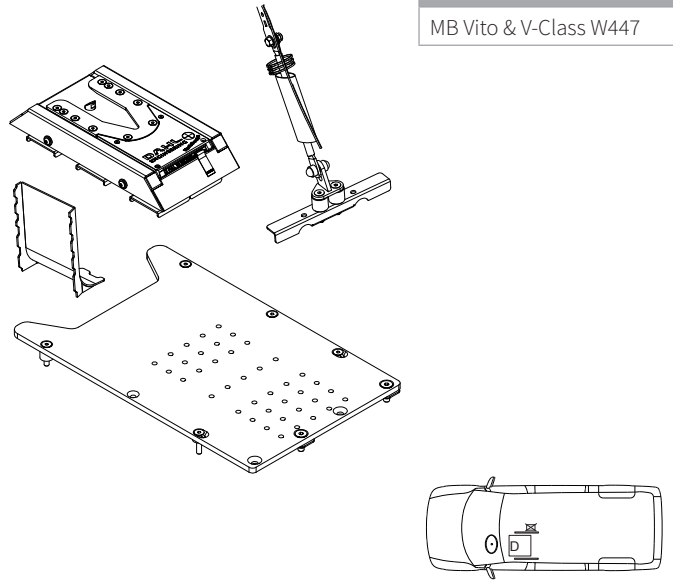

Art. No. 503920

Fiat Talento 2016-
MAN TGE 2017-
MB Sprinter 906, 907 & 910
Mitsubishi Express X82 (AU & NZ)
Nissan Primastar
Nissan NV300
Opel Vivaro X83 & X82
Renault Traffic X83 & X82
VW Crafter -2016
VW Crafter 2017-

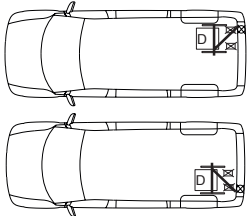

Art. No. 503920

Citroen Jumper Y
Citroen Jumpy X
Fiat Ducato X250
Fiat Talento
Fiat Scudo VX270
Ford Transit Custom V362
MB VITO W 639 & 447
Nissan Primastar
Nissan NV300
Opel Vivaro X83 & X82
Peugeot Boxer Y
Peugeot Expert X
Renault Traffic X83 & X82
Toyota Proace
VW T5 & T6

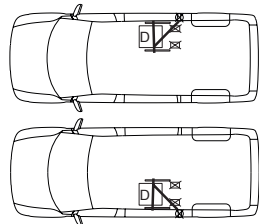

Art. No. 503921

Fiat Talento 2016-
MAN TGE 2017-
MB Sprinter 906, 907 & 910
Mitsubishi Express X82 (AU & NZ)
Nissan NV300
Nissan Primastar
Opel Vivaro X83 & X82
Renault Traffic X83 & X82
VW Crafter -2016
VW Crafter 2017-

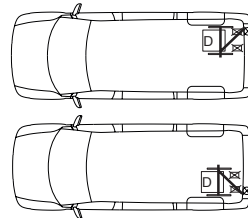

Art. No. 503921

Citroen Jumper Y
Citroen Jumpy X
Fiat Ducato X250
Fiat Scudo X270
Fiat Talento
Ford Transit Custom V362
MB VITO W 639 & 447
Nissan Primastar
Nissan NV300
Peugeot Boxer Y
Peugeot Expert X
Opel Vivaro X83 & X82
Renault Traffic X83 & X82
Toyota Proace
VW T5 & T6

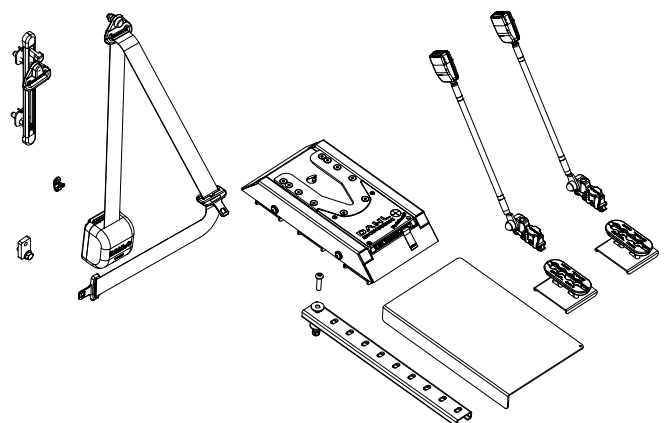
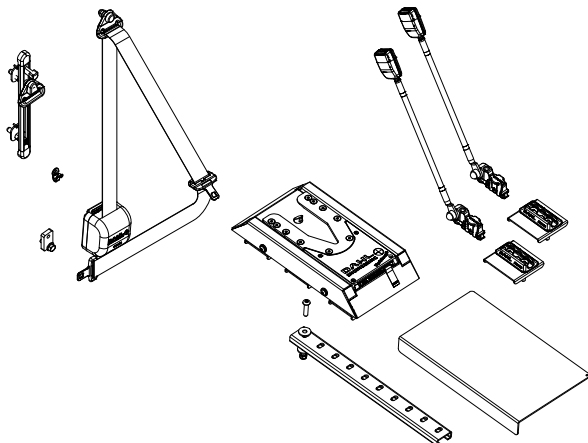
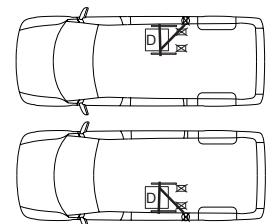

Kits d'installation pour la station d'arrimage VarioDock™ Dahl uniquement pour les fauteuils roulants

Art. No. 503922
VW T5 & T6

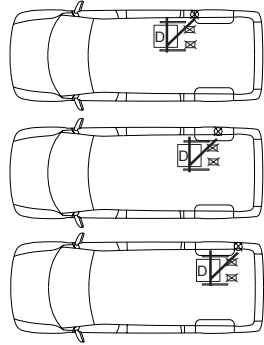
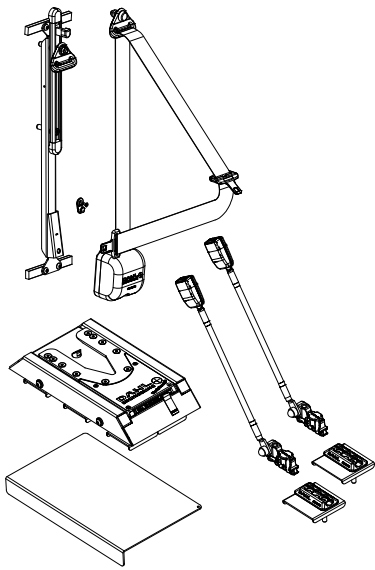

Art. No. 503923
VW T5 & T6

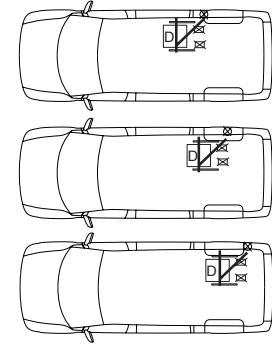
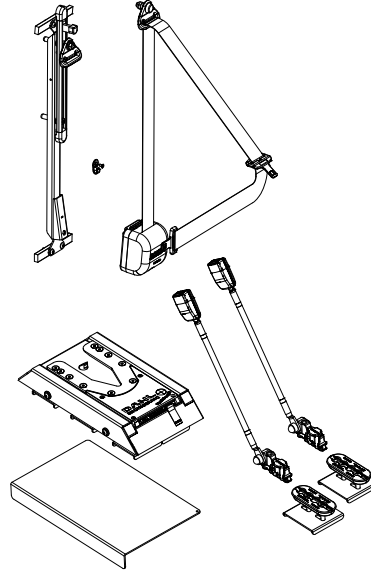

Art. No. 503924
MB Sprinter
906 & 907 & 910
VW Crafter (2006-2016)

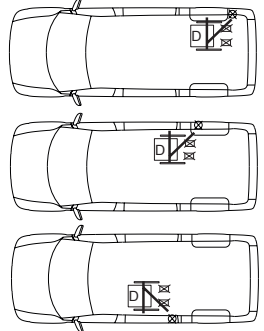
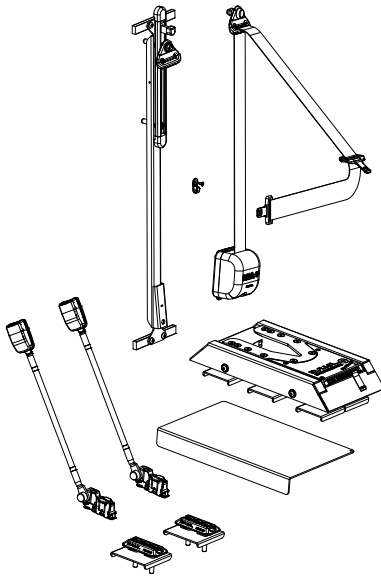

Art. No. 503925
MB Sprinter
906 & 907 & 910
VW Crafter (2006-2016)

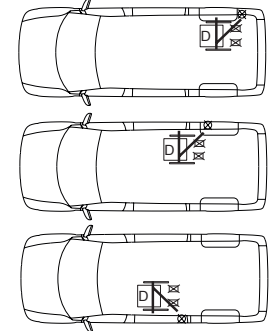
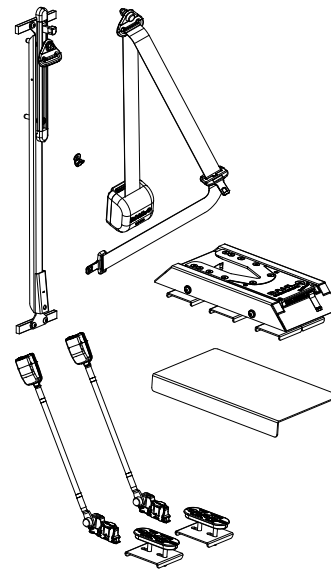

Art. No. 503926
Citroën Jumpy X
Fiat Scudo X270
Ford Transit Custom V362
MB Vito & V-Class W447
Peugeot Expert X
Toyota ProAce
VW T5 & T6

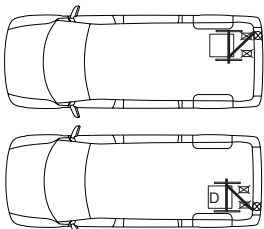
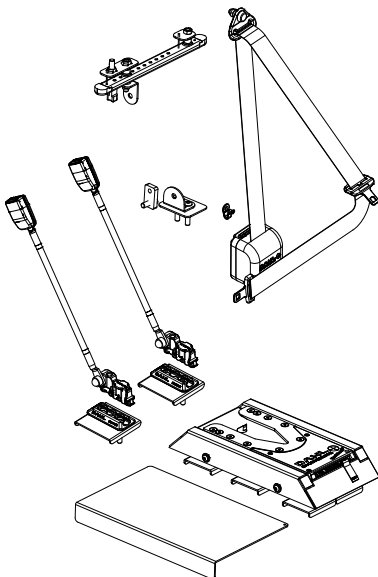

Art. No. 503927
Citroën Jumpy X
Fiat Scudo X270
Ford Transit Custom V362
MB Vito & V-Class W447
Peugeot Expert X
Toyota ProAce
VW T5 & T6

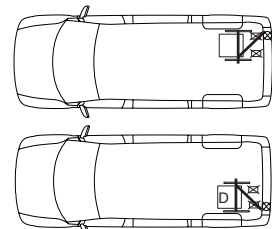
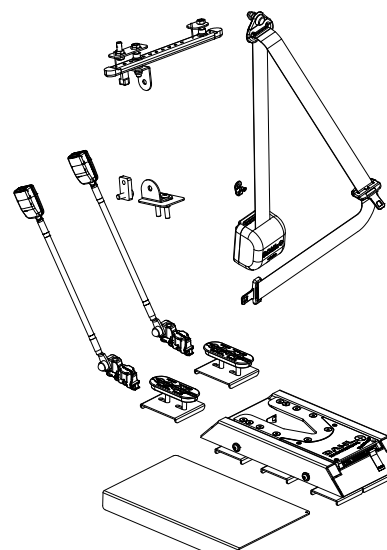

Kits d'installation pour la station d'arrimage VarioDock™ Dahl uniquement pour les fauteuils roulants

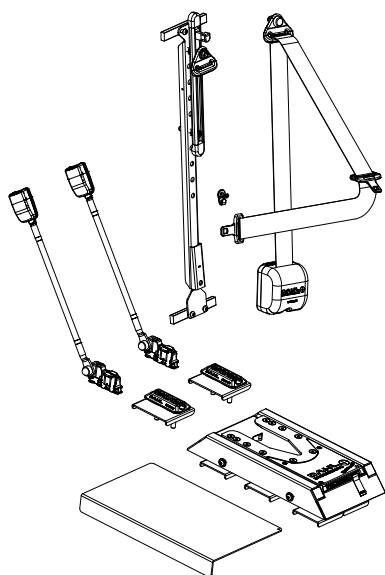

Art. No. 503928
Citroën Jumper Y
Fiat Ducato X250
Peugeot Boxer Y

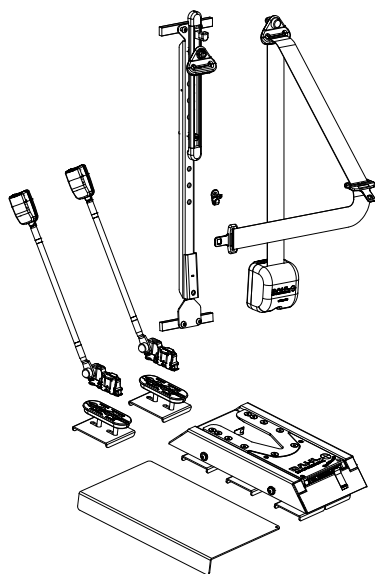
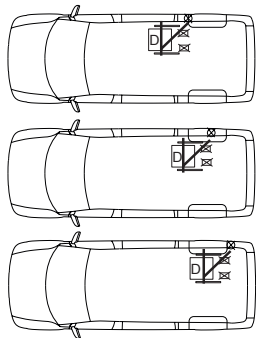

Art. No. 503929
Citroën Jumper Y
Fiat Ducato X250
Peugeot Boxer Y

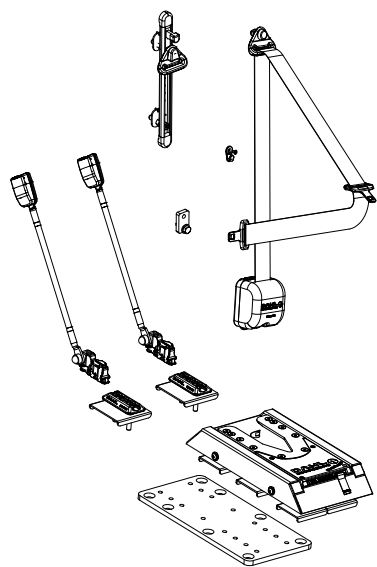
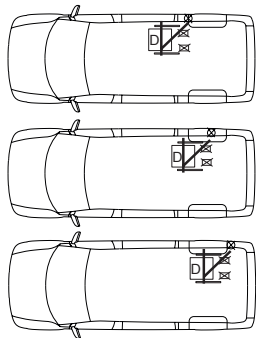

Art. No. 503930
Nissan NV 400
Opel Movano X62
Renault Master X62

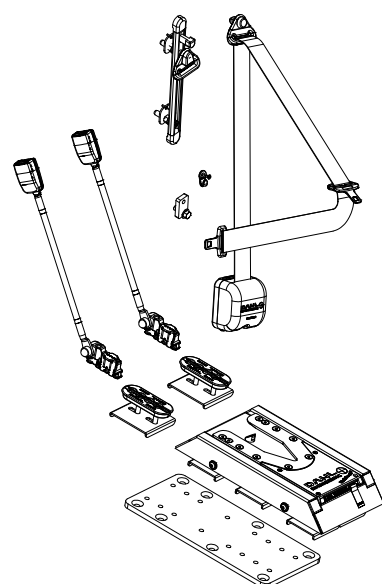
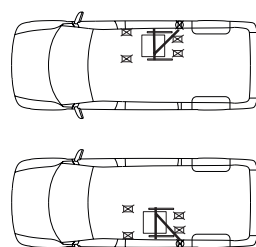

Art. No. 503931
Nissan NV 400
Opel Movano X62
Renault Master X62

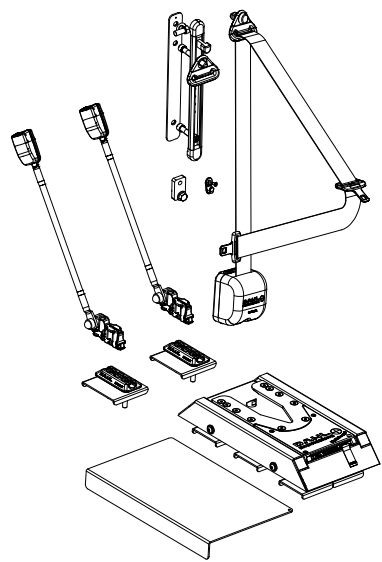
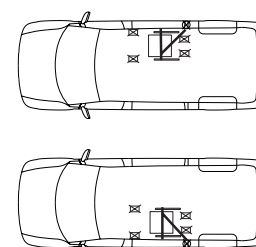

Art. No. 503932
Ford Transit V363

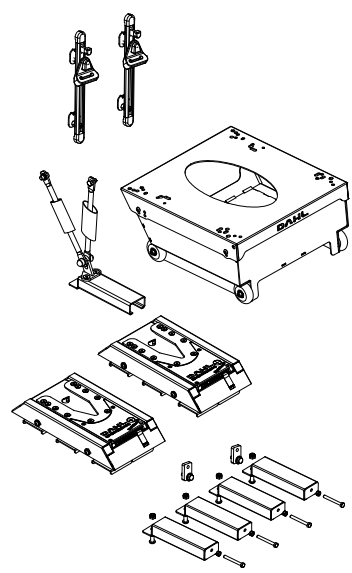
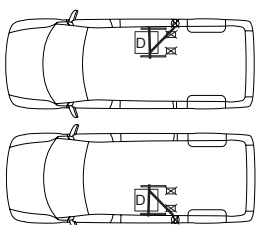

Art. No. 503933
GM Coachwork
Drop floor conversion:
VW Caravelle SE Colorado

Distribué en France et en Belgique par la Ste LENOIR Handi Concept

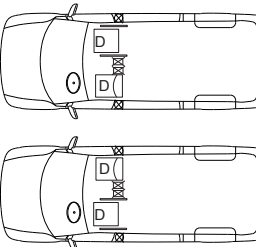

Kits d'installation pour la station d'arrimage VarioDock™ Dahl uniquement pour les fauteuils roulants

Art. No. 503934

GM Coachwork
Drop floor conversion:

VW Caravelle SE Colorado

Distribué en France et en
Belgique par la Ste LENOIR
Handi Concept

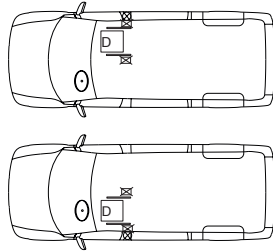
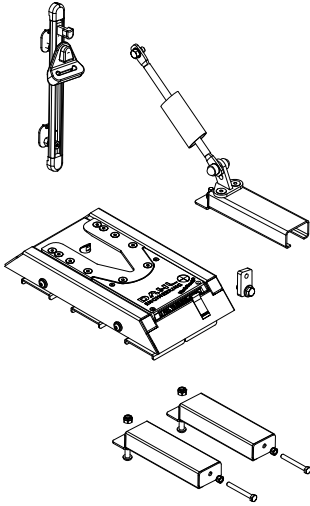

Art. No. 503935

GM Coachwork
Drop floor conversion:

VW Caravelle SE Colorado

Distribué en France et en
Belgique par la Ste LENOIR
Handi Concept

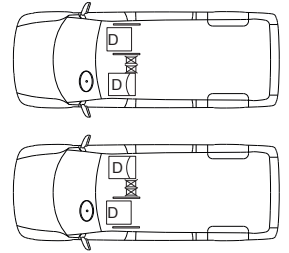
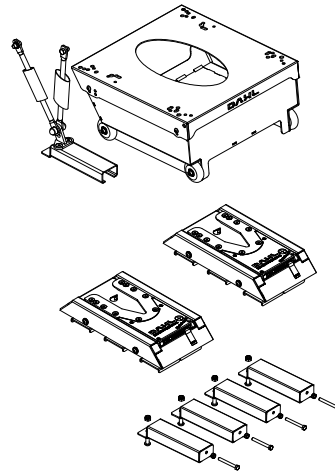

Art. No. 503936

GM Coachwork
Drop floor conversion:

VW Caravelle SE Colorado

Distribué en France et en
Belgique par la Ste LENOIR
Handi Concept

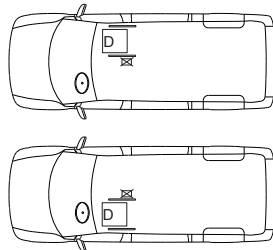
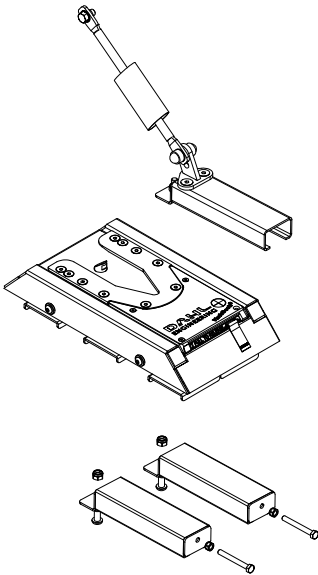

Art. No. 503937

Zawatzky Drop Floor
Conversion:

VW T6 Centervan

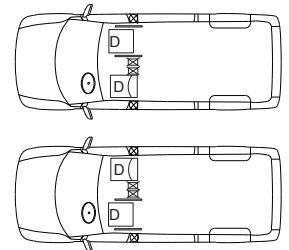
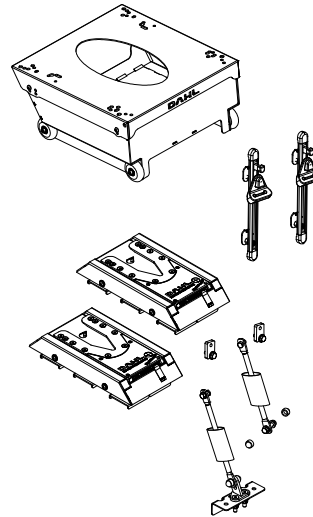

Art. No. 503938

Zawatzky Drop Floor
Conversion:

VW T6 Centervan

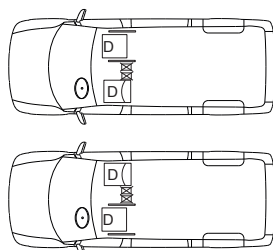
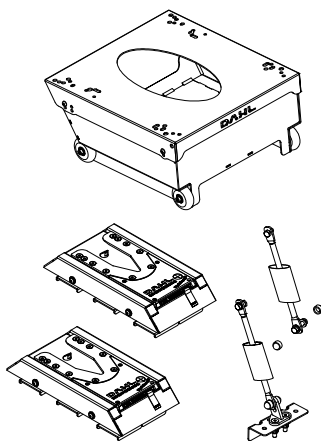

Art. No. 503939

Fiat Doblo
High roof SWB & LWB
Opel Combo
High roof SWB & LWB

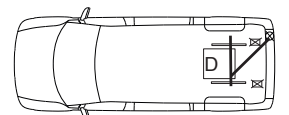
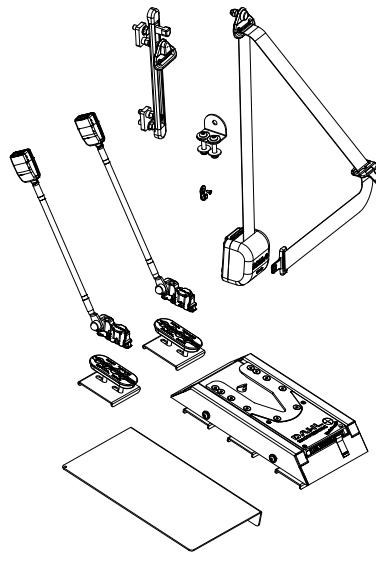

Kits d'installation pour la station d'arrimage VarioDock™ Dahl uniquement pour les fauteuils roulants

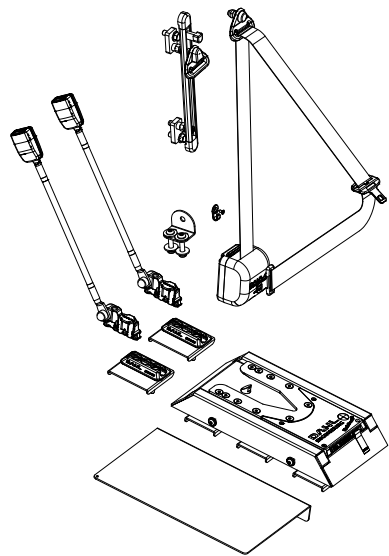

Art. No. 503940

Fiat Doblo
High roof SWB & LWB
Opel Combo
High roof SWB & LWB

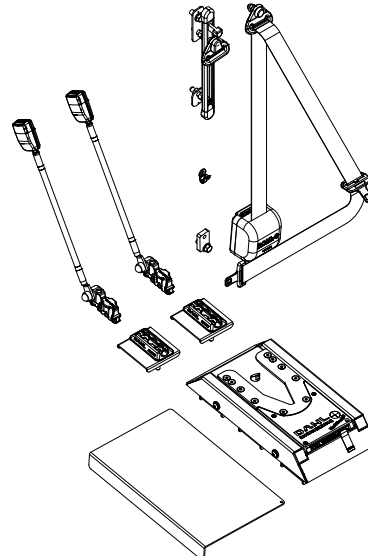
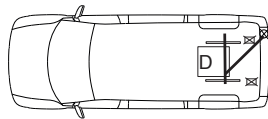

Art. No. 503941

VW Crafter 2017-
MAN TGE 2017-

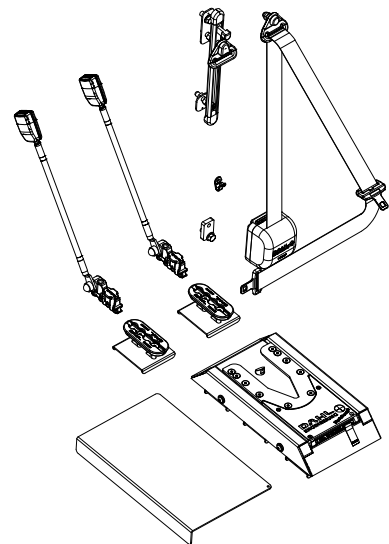
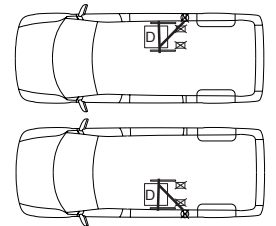

Art. No. 503942

VW Crafter 2017-
MAN TGE 2017-

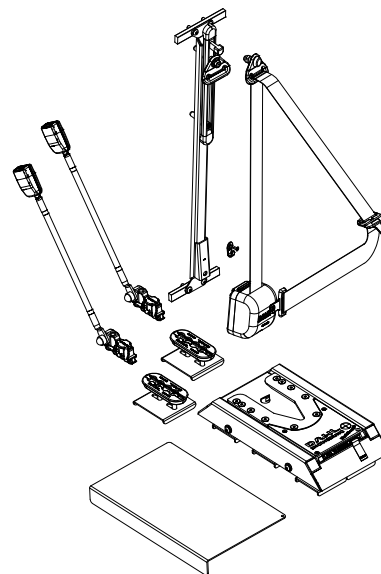
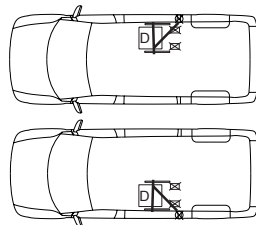

Art. No. 503943

VW Crafter 2017-
MAN TGE 2017-

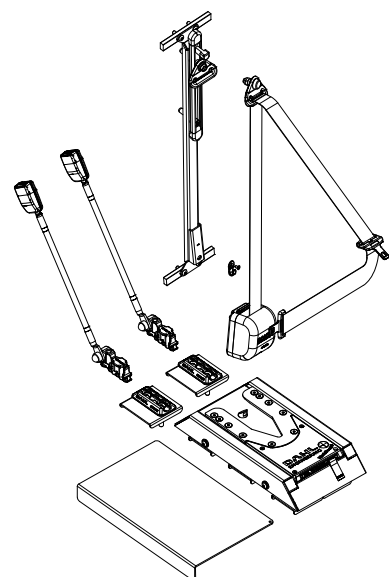
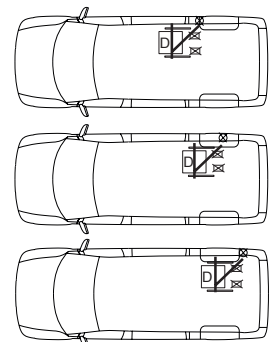

Art. No. 503944

VW Crafter 2017-
MAN TGE 2017-

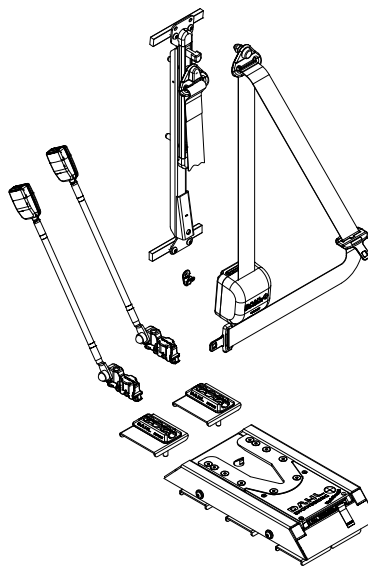
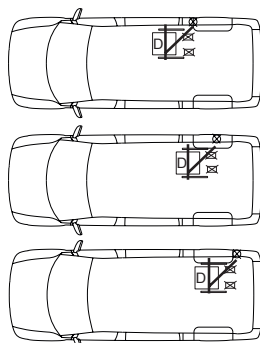

Art. No. 503945

Nissan NV 200

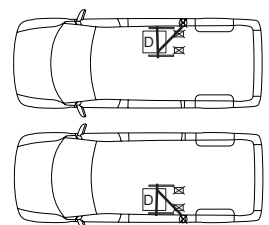

Kits d'installation pour la station d'arrimage VarioDock™ Dahl uniquement pour les fauteuils roulants

Art. No. 503946

Citroën Jumpy &
Spacetourer KO
Opel Zafira Life
Peugeot Expert &
Traveller KO
Toyota Proace &
Proace Verso 2016-

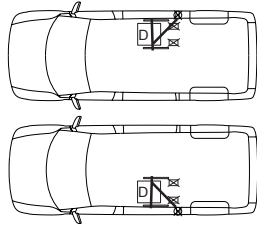
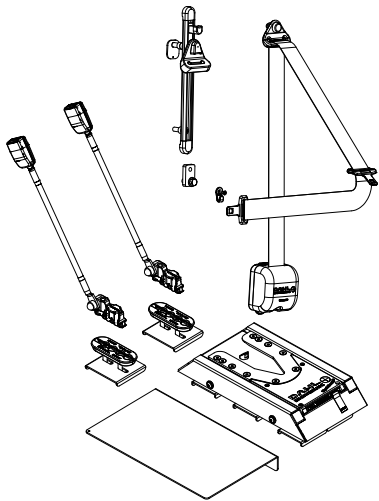

Art. No. 503947

ITEK Drop Floor
Conversion:
VW Caddy Active

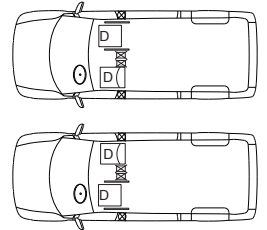
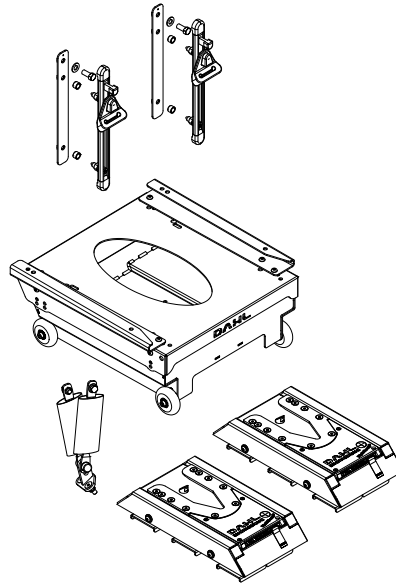

Art. No. 503948

ITEK Drop Floor
Conversion:
VW Caddy Active

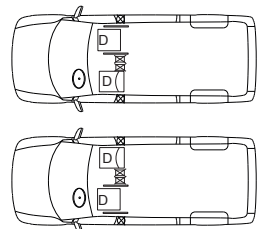
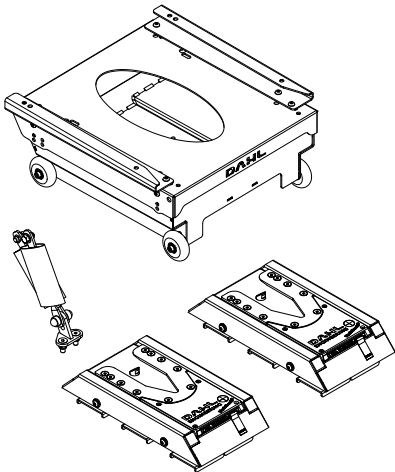

Art. No. 503949

Citroën Jumpy &
Spacetourer KO
Opel Zafira Life
Peugeot Expert &
Traveller KO
Toyota Proace &
Proace Verso 2016-

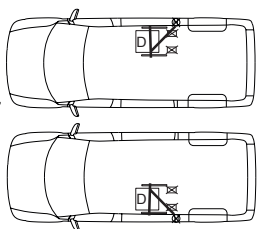
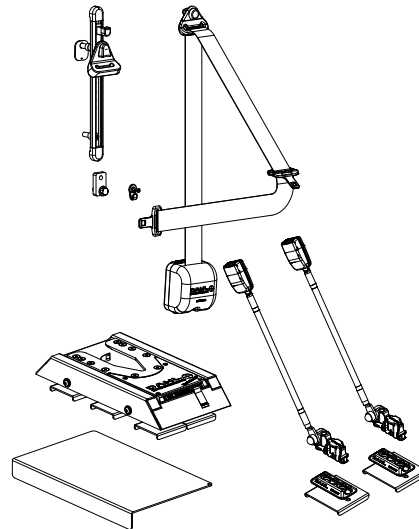

Art. No. 503950

Citroën Jumpy &
Spacetourer KO
Opel Zafira Life
Peugeot Expert &
Traveller KO
Toyota Proace &
Proace Verso 2016-

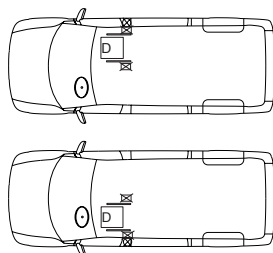
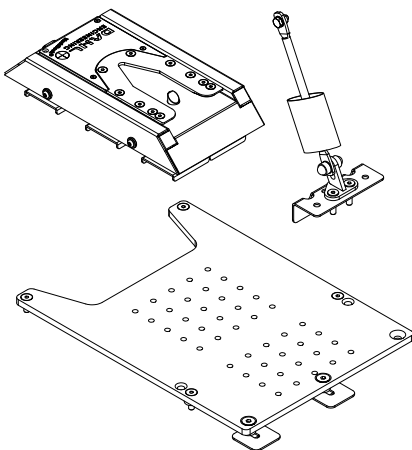

Art. No. 503951

Citroën Jumpy &
Spacetourer KO
Opel Zafira Life
Peugeot Expert &
Traveller KO
Toyota Proace &
Proace Verso 2017-

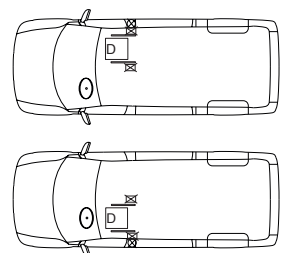
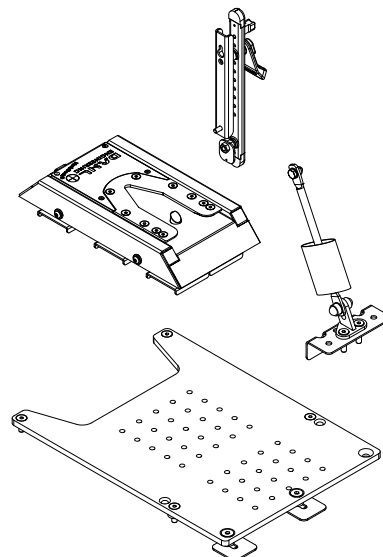

Kits d'installation pour la station d'arrimage VarioDock™ Dahl uniquement pour les fauteuils roulants

Art. No. 503952

Citroën Jumpy &
Spacetourer KO
Opel Zafira Life
Peugeot Expert &
Traveller KO
Toyota Proace &
Proace Verso 2016-

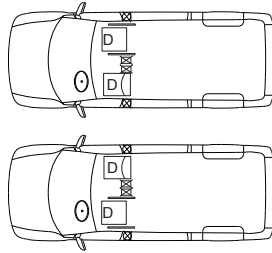
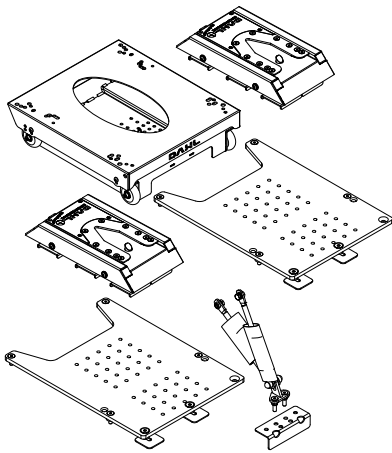

Art. No. 503953

Citroën Jumpy &
Spacetourer KO
Opel Zafira Life
Peugeot Expert &
Traveller KO
Toyota Proace &
Proace Verso 2016-

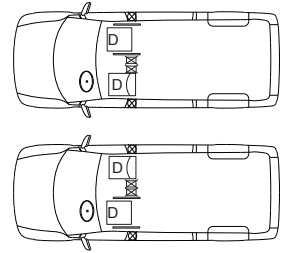
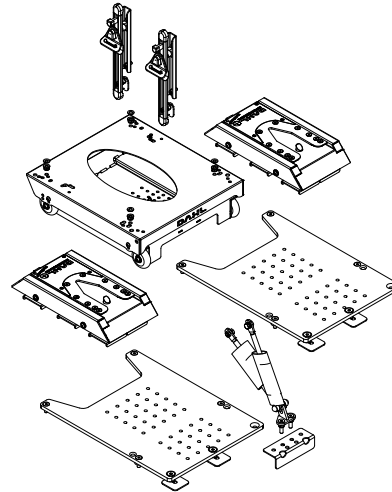

Art. No. 503954

Tripod/Allied Drop Floor
Conversion:
Citroën Berlingo
Peugeot Partner

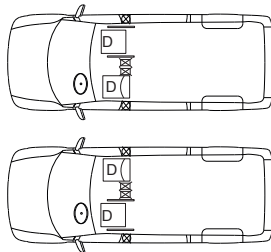
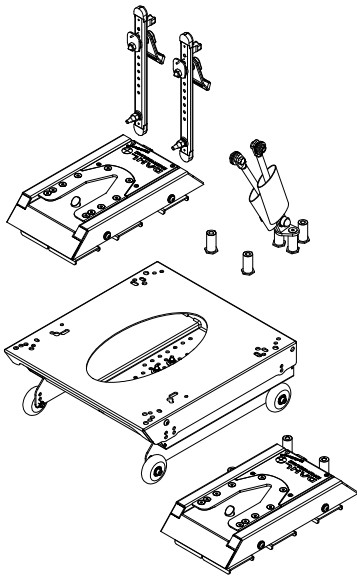

Art. No. 503005

MB Vito
MB V-Class 447

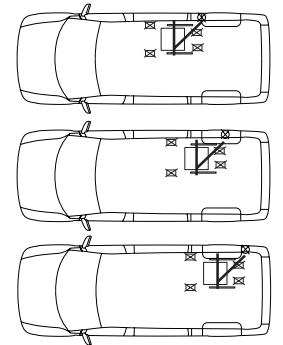
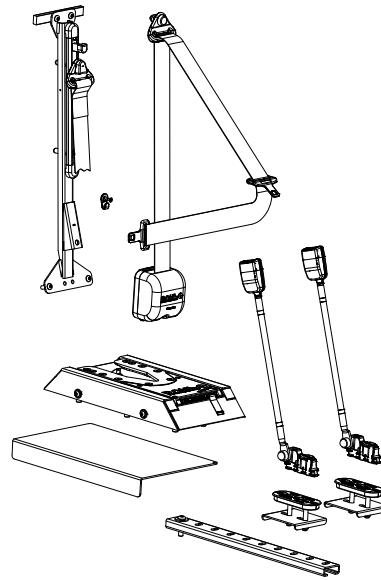

Art. No. 503007

MB Vito
MB V-Class 447

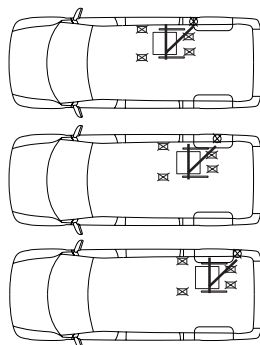
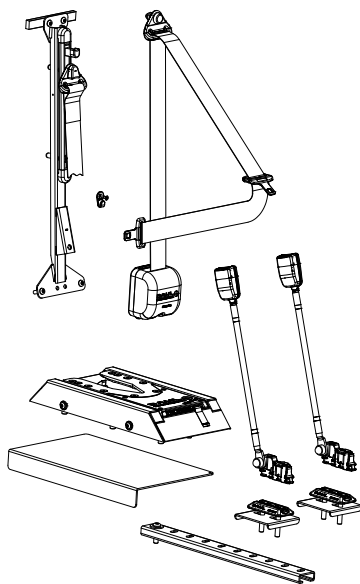

Art. No. 500222 *

Ford Transit Custom V710
VW New Transporter /
Caravelle 2025-

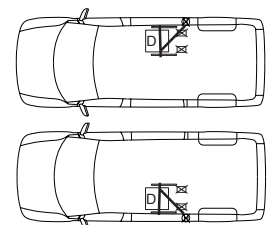
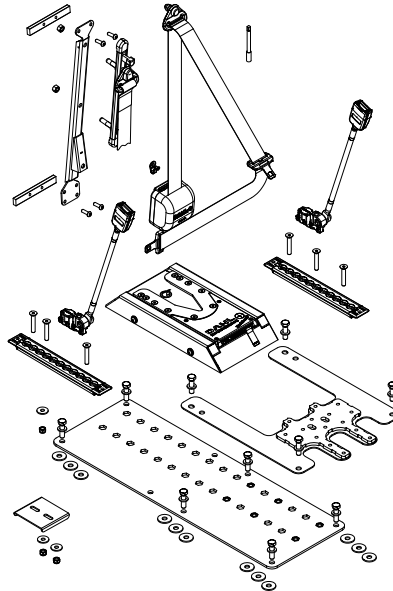

* Voir aussi la liste de compatibilité à la page 10.

Kits d'installation pour la station d'arrimage VarioDock™ Dahl uniquement pour les fauteuils roulants

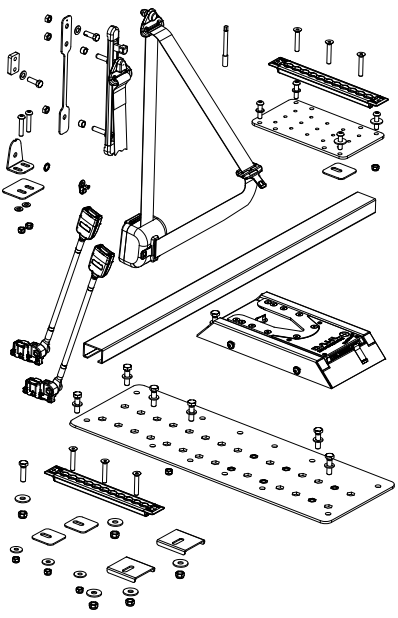

Art. No. 500255 *

Ford Transit Custom V710
VW New Transporter /
Caravelle 2025-

FMVSS/CMVSS 210

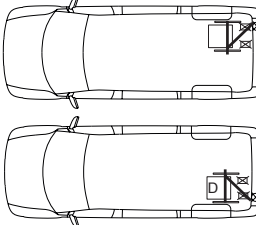
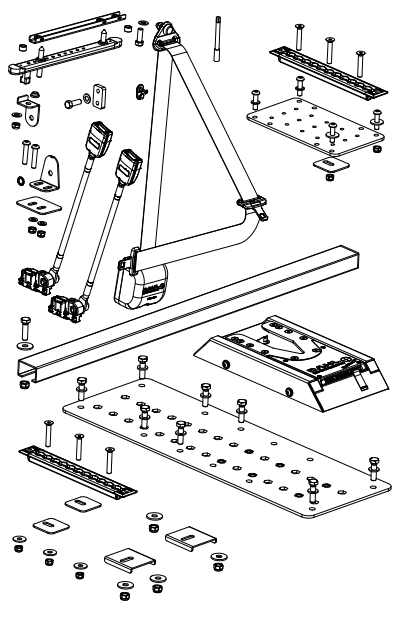
Art. No. 500256 *

Ford Transit Custom V710
VW New Transporter /
Caravelle 2025-

FMVSS/CMVSS 210

Art. No. 504064 *

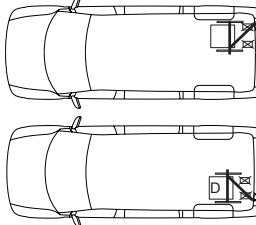
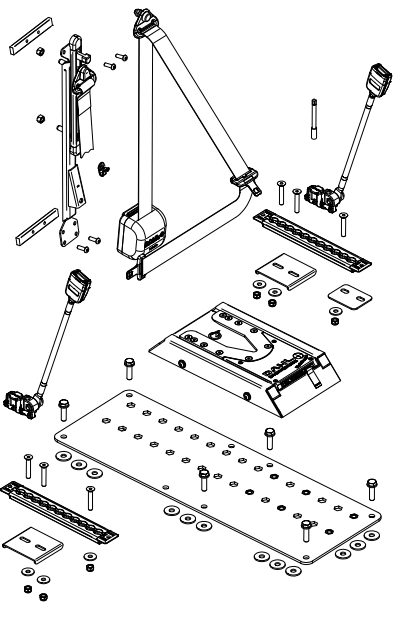
Ford Transit Custom V710
VW New Transporter /
Caravelle 2025-

FMVSS/CMVSS 210

Art. No. 504148 *

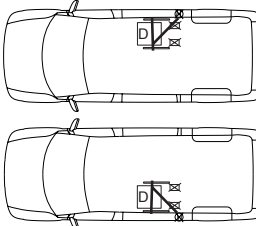
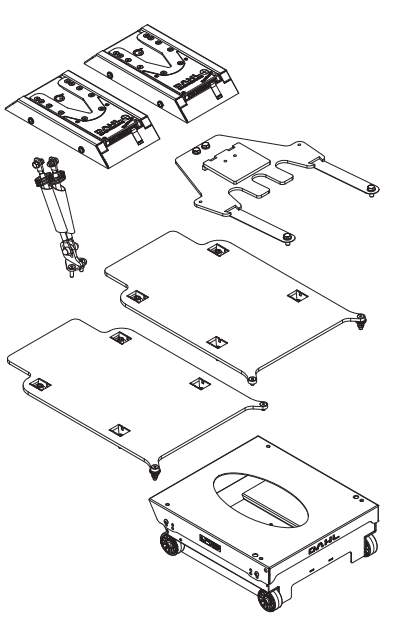
Ford Transit Custom V710
VW New Transporter /
Caravelle 2025-

FMVSS/CMVSS 207/210

Art. No. 504150 *

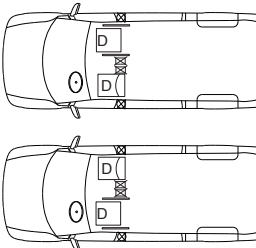
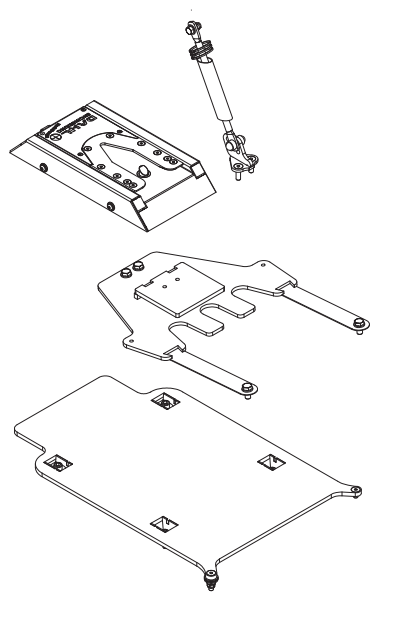
Ford Transit Custom V710
VW New Transporter /
Caravelle 2025-

FMVSS/CMVSS 207/210

Art. No. 504159

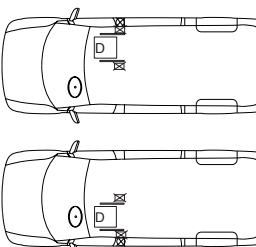
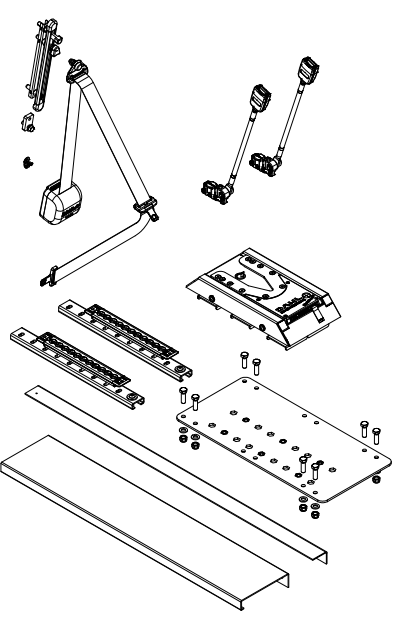
Renault Master XDD
Nissan Interstar 2024-

FMVSS/CMVSS 210

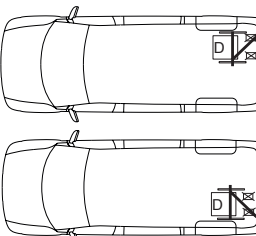

* Voir aussi la liste de compatibilité à la page 10.

Kits d'installation pour la station d'arrimage VarioDock™ Dahl uniquement pour les fauteuils roulants

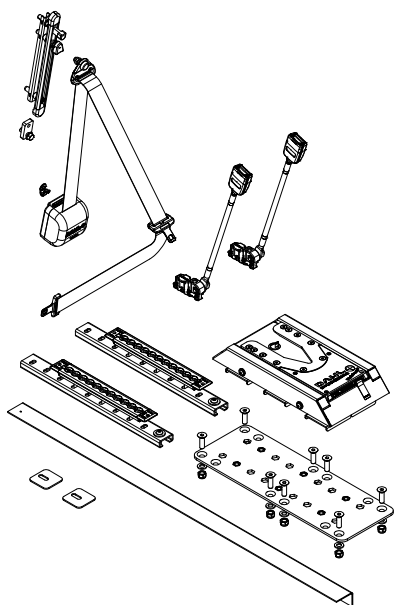

Art. No. 504163

Renault Master XDD
Nissan Interstar 2024-

FMVSS/CMVSS
210

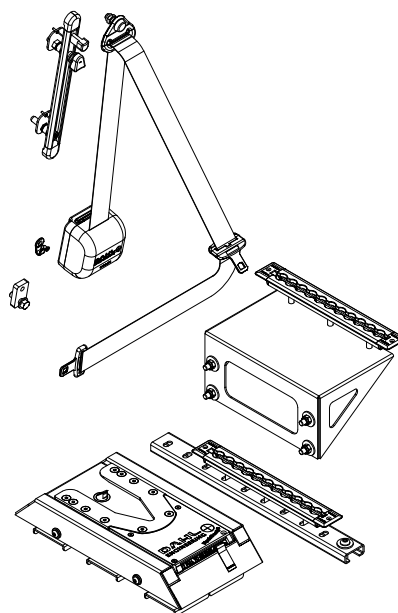
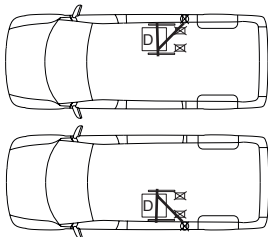

Art. No. 504166

Mercedes Sprinter
907/9710

FMVSS/CMVSS
210

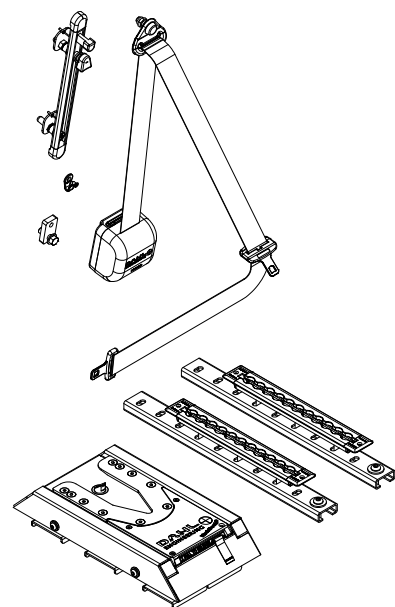
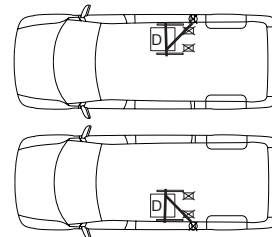

Art. No. 504168

Mercedes Sprinter
907/9710

FMVSS/CMVSS
210

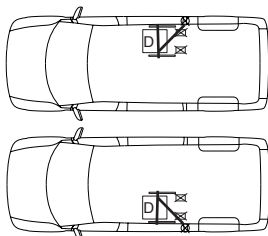

Station d'arrimage Dahl MK II

Dahl Docking Station MK II est notre station d'arrimage de deuxième génération, qui permet la fixation de fauteuils roulants issus de nombreux fabricants.



- Conforme aux normes ISO 10542-1, ISO 7176-19 et aux exigences de test conformément aux réglementations ECE 14 et 17 sur les essais de sièges et ancrages de ceintures de sécurité dans la catégorie de véhicules M1.
- Réglage de la hauteur avec l'utilisation d'entretoises.
- Testé pour les fauteuils roulants pesant jusqu'à 200 kg plus l'utilisateur.
- Crash testé et marqué CE avec env. 160+ fauteuils roulants.



Kits d'installation pour la Station d'Arrimage Dahl MK II

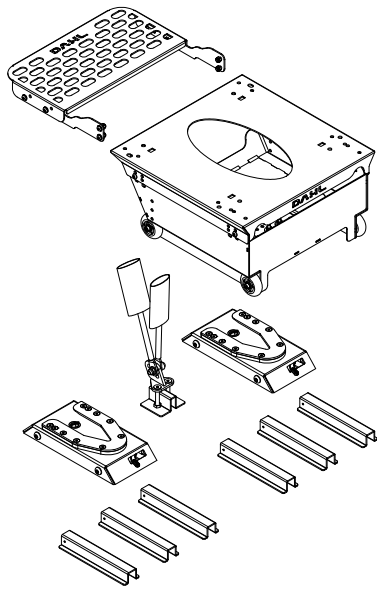

Art. No. 501551
 ACA Dropfloor
 Conversion:
 Jeep Renegade

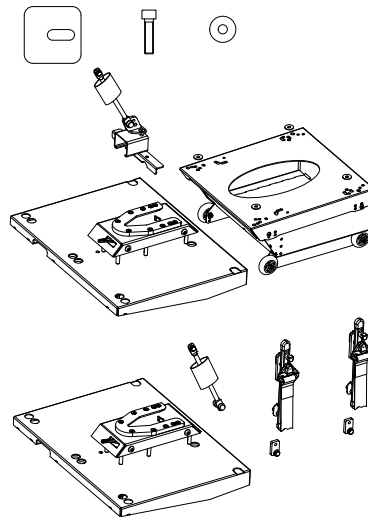
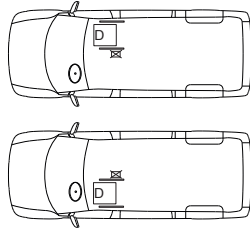

Art. No. 501970
 MB Sprinter 906 & 907
 VW Crafter (2006-2016)

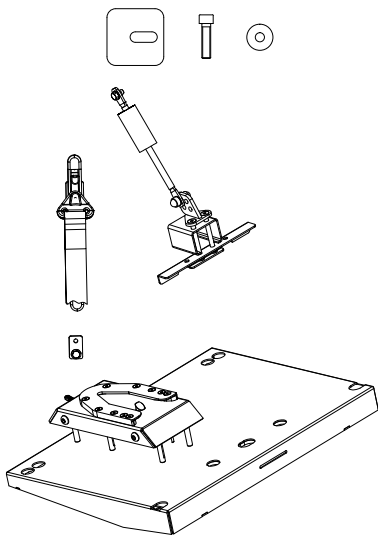
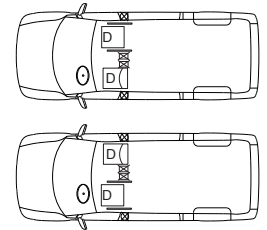

Art. No. 501971
 MB Sprinter 906 & 907
 VW Crafter (2006-2016)

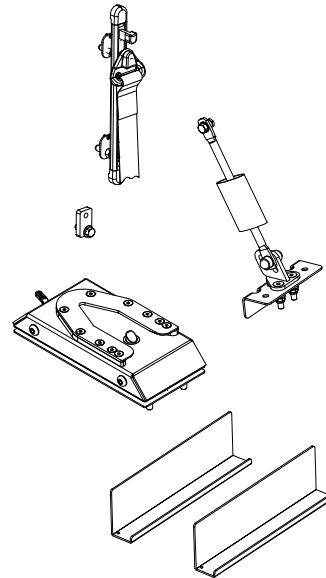
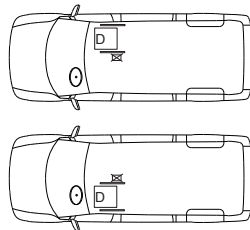

Art. No. 501973
 VW T5 & T6

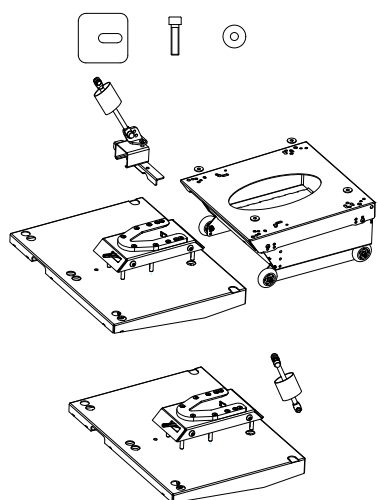
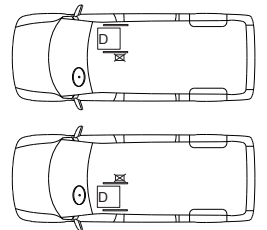

Art. No. 502034
 MB Sprinter 906 & 907
 VW Crafter (2006-2016)

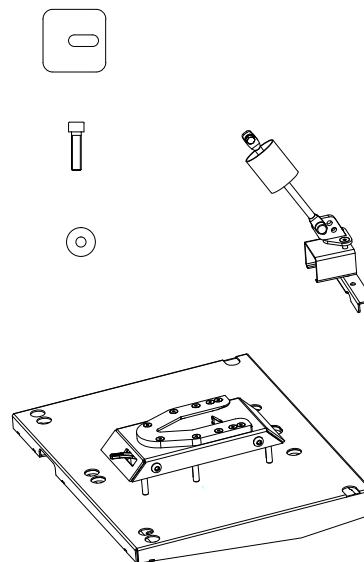
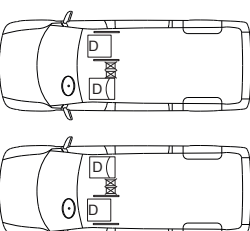

Art. No. 502035
 MB Sprinter 906 & 907
 VW Crafter (2006-2016)

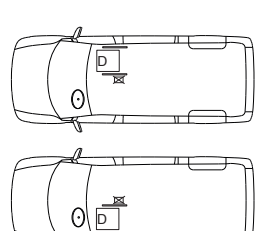

Kits d'installation pour la Station d'Arrimage Dahl MK II

Art. No. 502036

VW T5 & T6

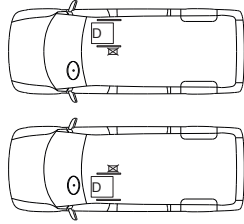
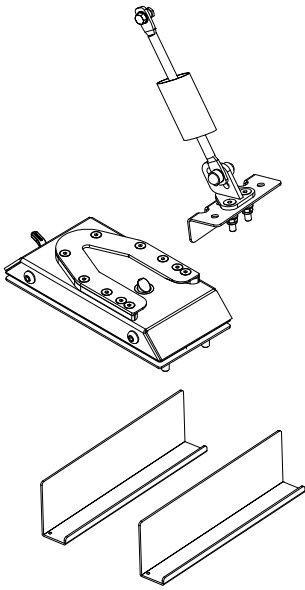

Art. No. 502037

VW T5 & T6

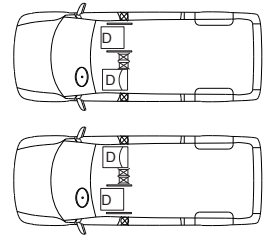
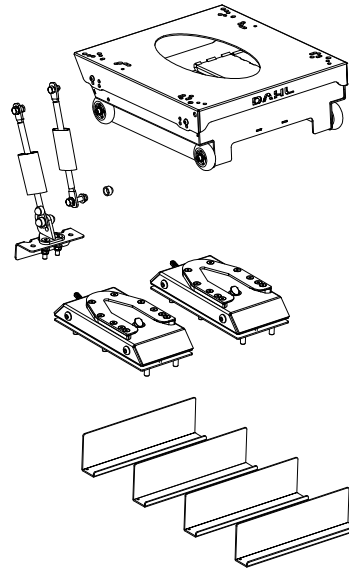

Art. No. 502039

Renault Master X62
Opel Movano X62
Nissan NV400

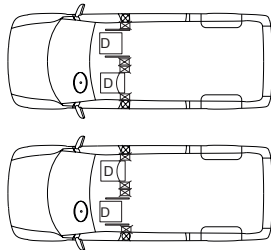
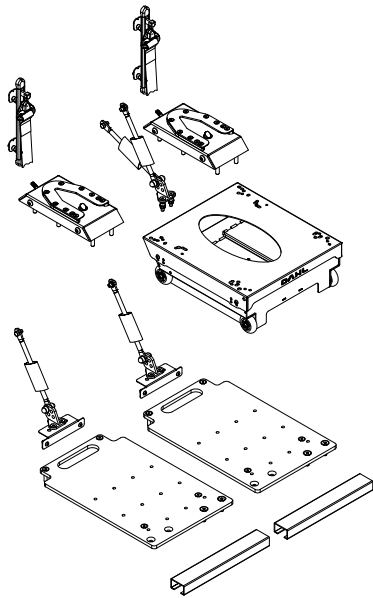

Art. No. 502040

VW T5 & T6

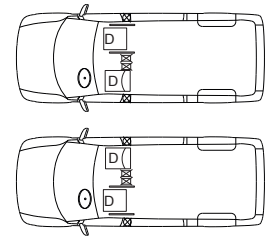
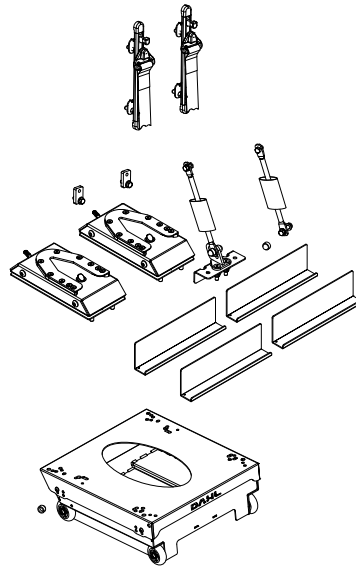

Art. No. 502041

Renault Master X62
Opel Movano X62
Nissan NV400

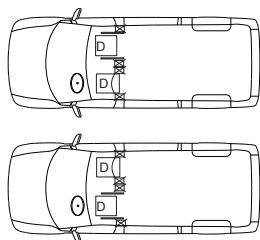
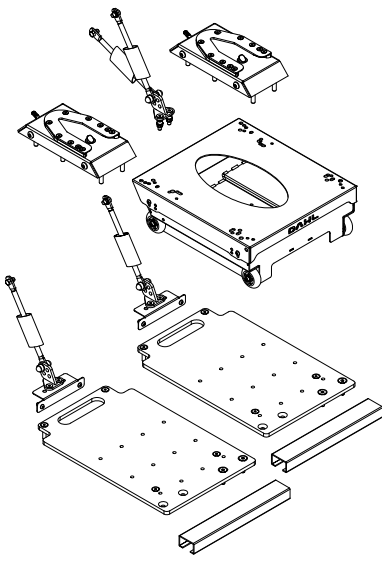

Art. No. 502042

Renault Master X62
Opel Movano X62
Nissan NV400

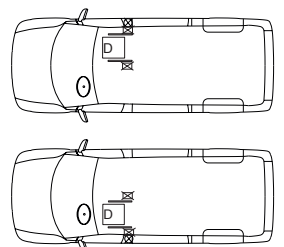
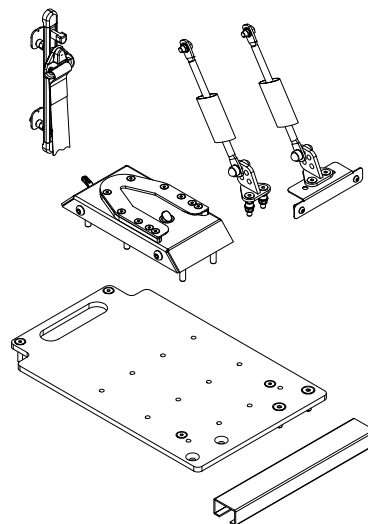

Kits d'installation pour la Station d'Arrimage Dahl MK II

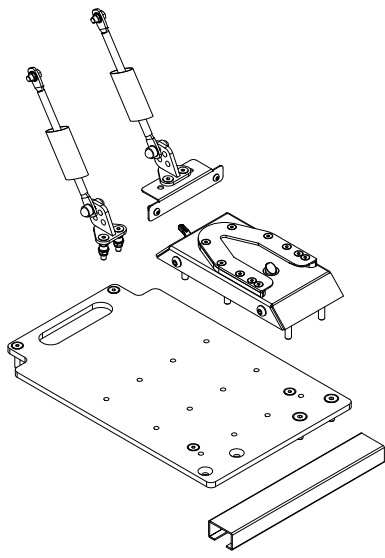

Art. No. 502043

Renault Master X62

Opel Movano X62

Nissan NV400

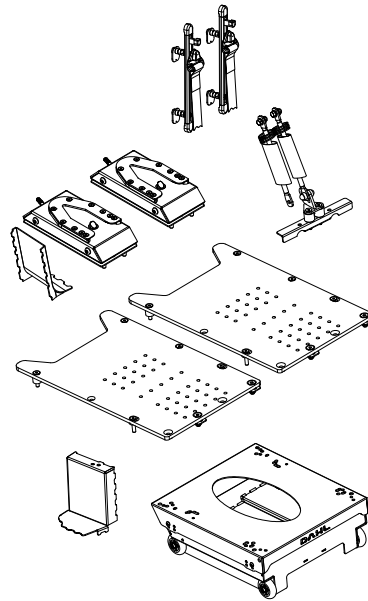
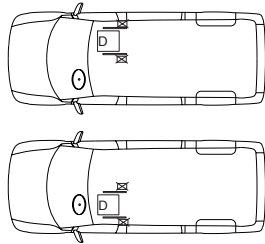

Art. No. 502163

MB Vito & V-Class W447

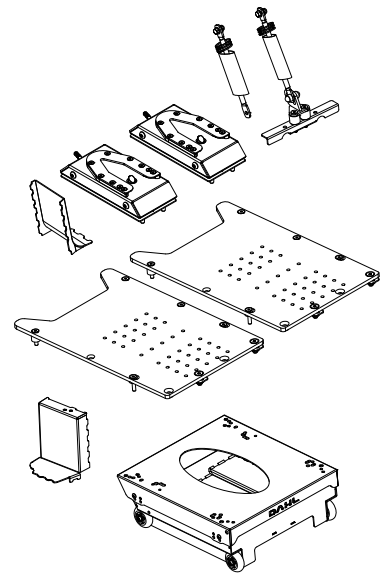
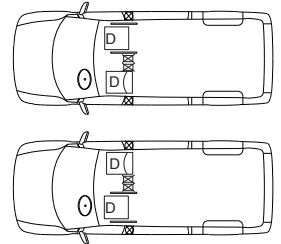

Art. No. 502164

MB Vito & V-Class W447

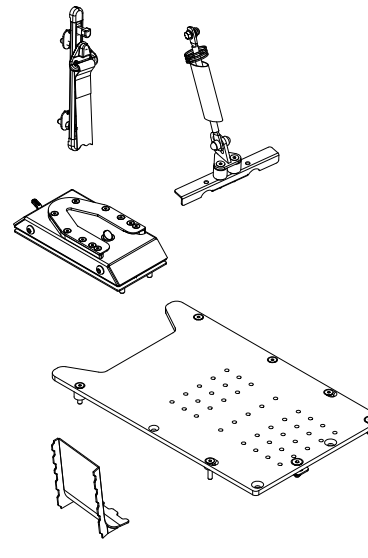
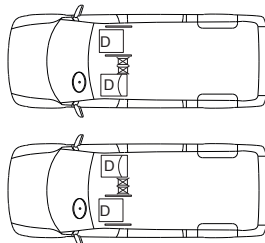

Art. No. 502165

MB Vito & V-Class W447

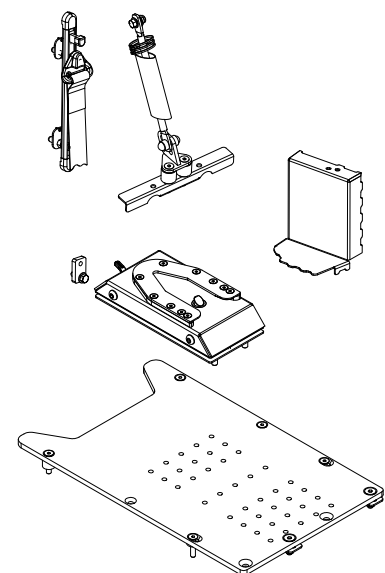
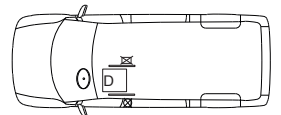

Art. No. 502166

MB Vito & V-Class W447

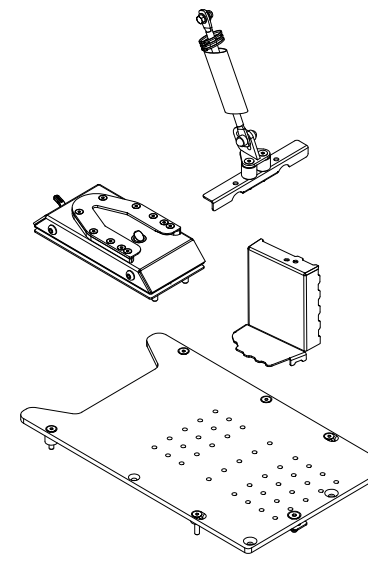
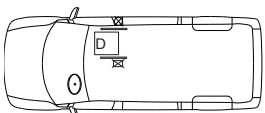

Art. No. 502167

MB Vito & V-Class W447

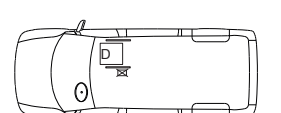

Kits d'installation pour la Station d'Arrimage Dahl MK II

Art. No. 502168

MB Vito & V-Class W447

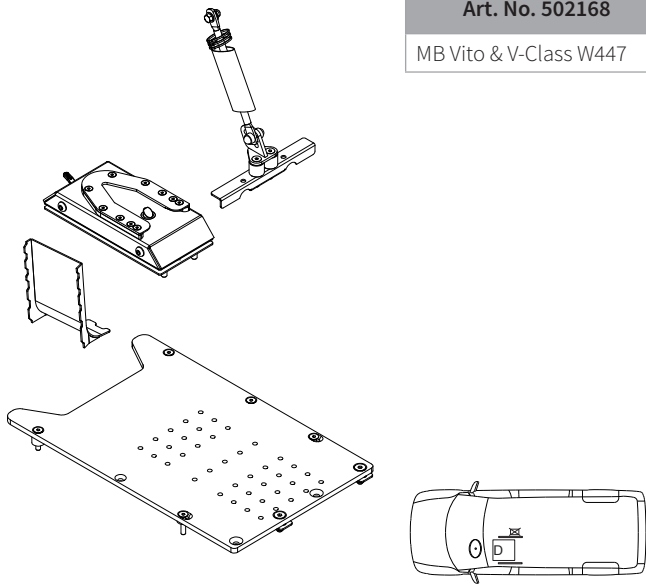

Art. No. 502171

Fiat Talento 2016-
 Man TGE 2017-
 MB Sprinter 906 & 907 & 910
 Mitsubishi Express (AU+NZ)
 Nissan NV300
 Nissan Primastar
 Opel Vivaro X83 & X82
 Renault Traffic X83 & X82
 VW Crafter -2016
 VW Crafter 2017-

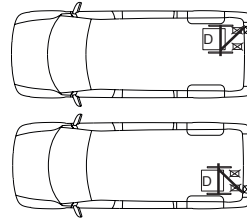

Art. No. 502171

Citroën Jumper Y
 Citroën Jumpy X
 Fiat Ducato X250
 Fiat Scudo X270
 Fiat Talento 2016-
 Ford Transit Custom V362
 MB Vito W639 & W447
 Mitsubishi Express (AU+NZ)
 Nissan NV300
 Nissan Primastar
 Opel Vivaro X83 & X82
 Peugeot Boxer Y
 Peugeot Expert X
 Renault Trafic X83 & X82
 Toyota Proace
 VW T5 & T6

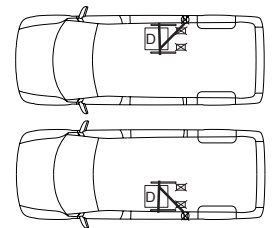

Art. No. 502172

Fiat Talento 2016-
 Man TGE 2017-
 MB Sprinter 906 & 907 & 910
 Mitsubishi Express (AU+NZ)
 Nissan NV300
 Nissan Primastar
 Opel Vivaro X83 & X82
 Renault Traffic X83 & X82
 VW Crafter -2016
 VW Crafter 2017-

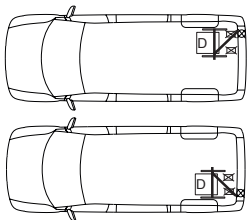

Art. No. 502172

Citroën Jumper Y
 Citroën Jumpy X
 Fiat Ducato X250
 Fiat Scudo X270
 Fiat Talento
 Ford Transit Custom V362
 MB Vito W639 & W447
 Mitsubishi Express (AU+NZ)
 Nissan NV300
 Nissan Primastar
 Opel Vivaro X83 & X82
 Peugeot Boxer Y
 Peugeot Expert X
 Renault Trafic X83 & X82
 Toyota Proace
 VW T5 & T6

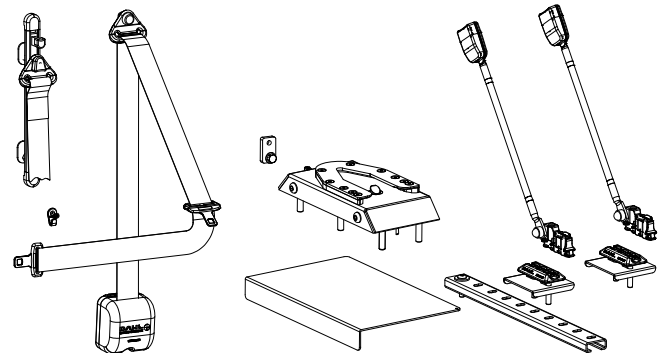
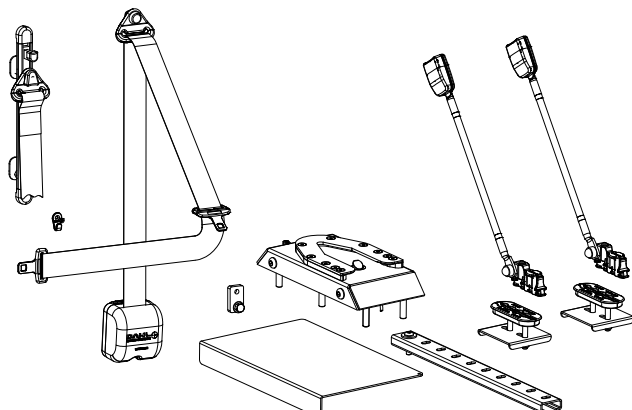
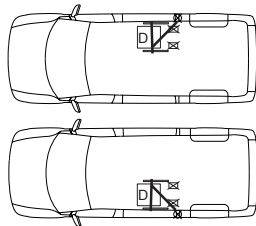

Art. No. 502173

VW T5 & T6

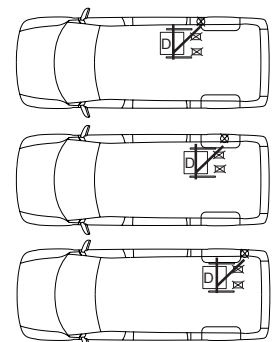
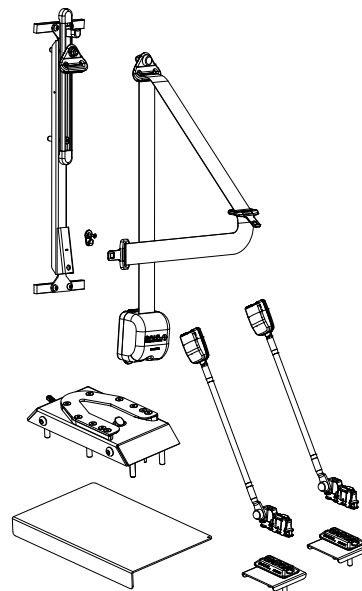

Kits d'installation pour la Station d'Arrimage Dahl MK II

Art. No. 502174

VW T5 & T6

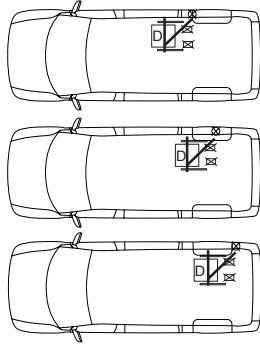
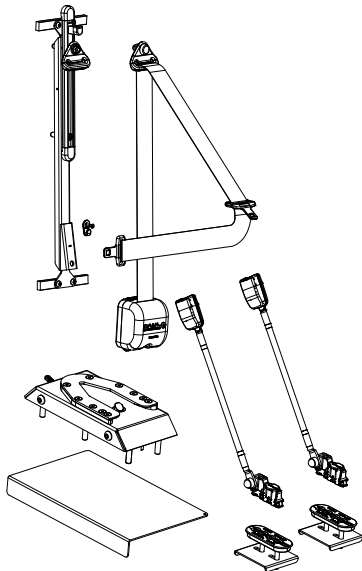

Art. No. 502175

MB Sprinter
906 & 907 & 910
VW Crafter (2006-2016)

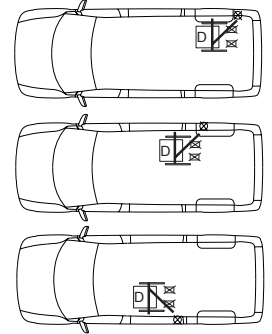
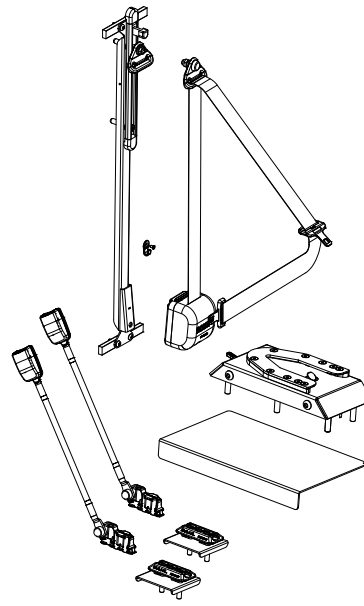

FMVSS/CMVSS
210

Art. No. 502176

MB Sprinter
906 & 907 & 910
VW Crafter (2006-2016)

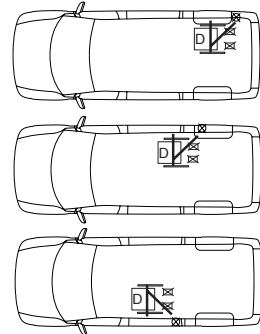
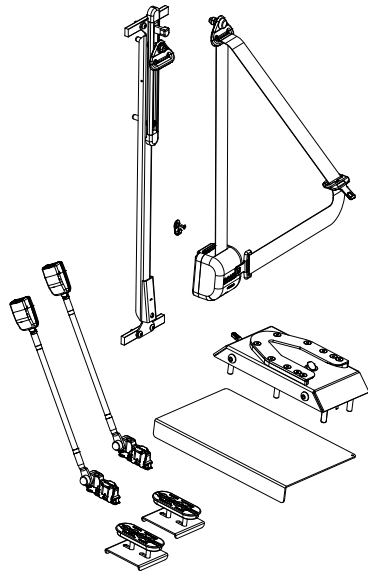

FMVSS/CMVSS
210

Art. No. 502177

Citroën Jumpy X
Fiat Scudo X270
Ford Transit Custom V362
MB Vito & V-Class W447
Peugeot Expert X
Toyota ProAce
VW T5 & T6

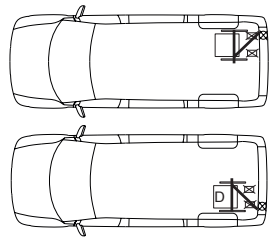
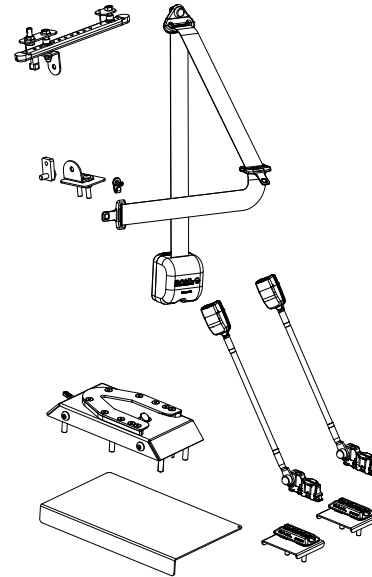

Art. No. 502178

Citroën Jumpy X
Fiat Scudo X270
Ford Transit Custom V362
MB Vito & V-Class W447
Peugeot Expert X
Toyota ProAce
VW T5 & T6

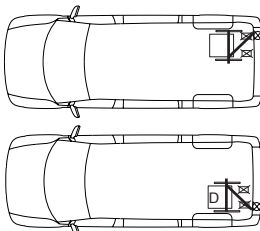
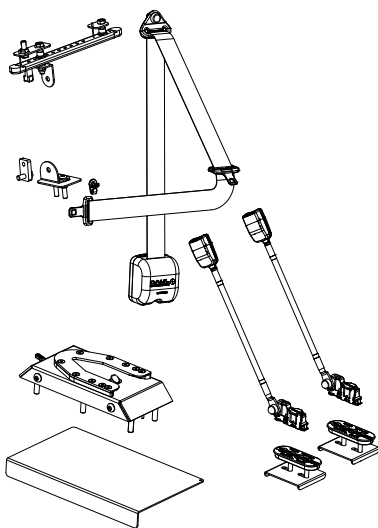

Art. No. 502179

Citroën Jumper Y
Fiat Ducato X250
Peugeot Boxer Y

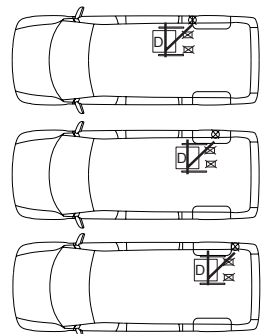
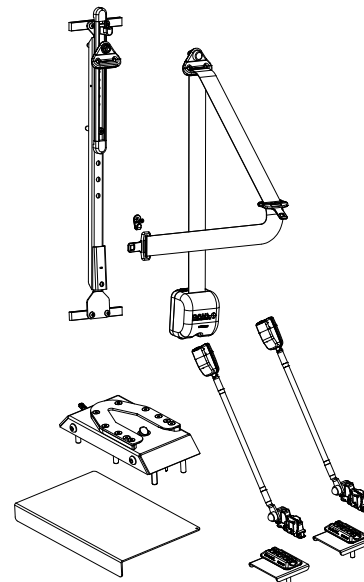

Kits d'installation pour la Station d'Arrimage Dahl MK II

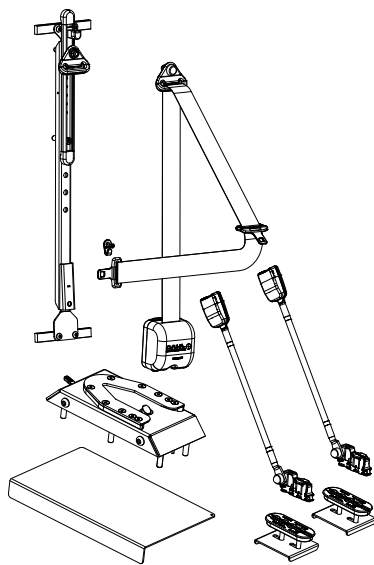

Art. No. 502180
 Citroën Jumper Y
 Fiat Ducato X250
 Peugeot Boxer Y

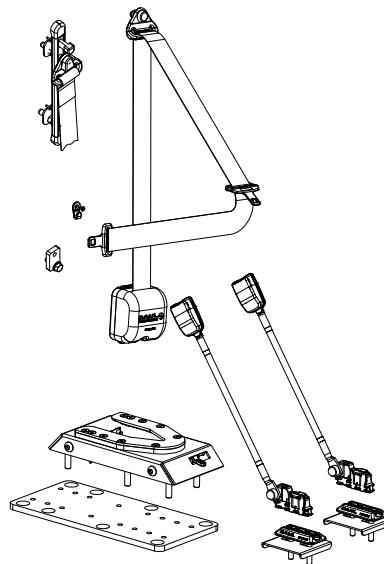
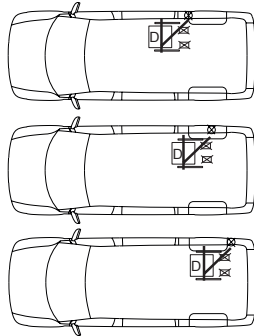

Art. No. 502181
 Nissan NV 400
 Opel Movano X62
 Renault Master X62

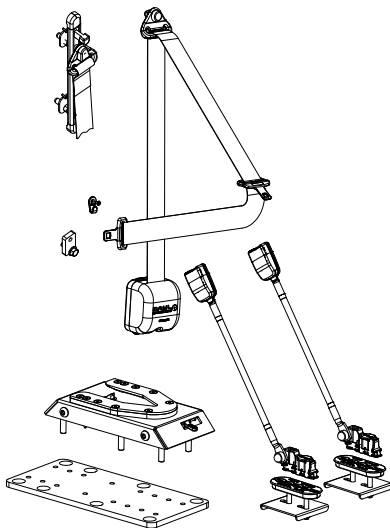
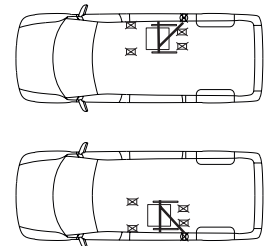

Art. No. 502182
 Nissan NV 400
 Opel Movano X62
 Renault Master X62

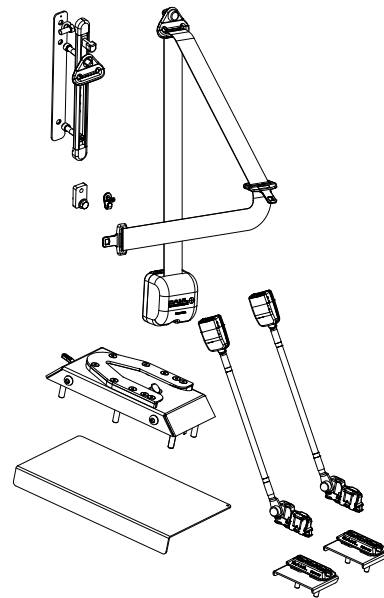
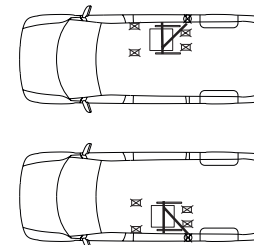

Art. No. 502194
 Ford Transit V363

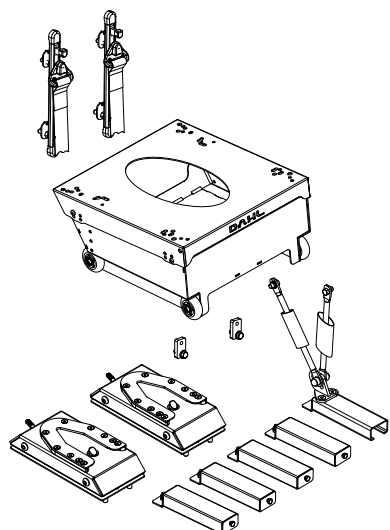
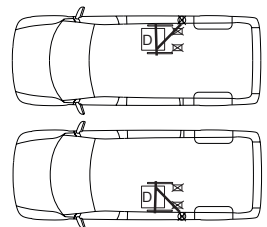

Art. No. 502285
 GM Coachwork
 Drop floor conversion:
 VW Caravelle SE Colorado
 Distribué en France et en
 Belgique par la Ste LENOIR
 Handi Concept

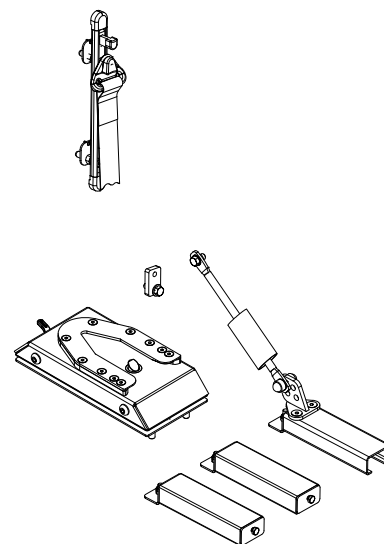
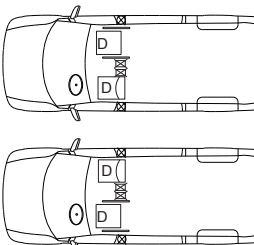

Art. No. 502286
 GM Coachwork
 Drop floor conversion:
 VW Caravelle SE Colorado
 Distribué en France et en
 Belgique par la Ste LENOIR
 Handi Concept

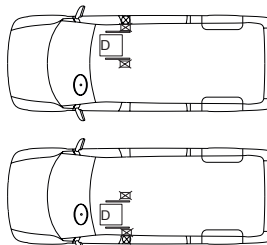

Kits d'installation pour la Station d'Arrimage Dahl MK II

Art. No. 502287

GM Coachwork
Drop floor conversion:
VW Caravelle SE Colorado

Distribué en France et en Belgique par la Ste LENOIR Handi Concept

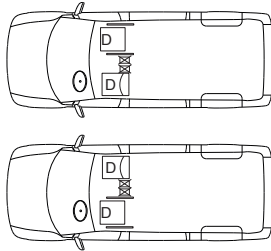
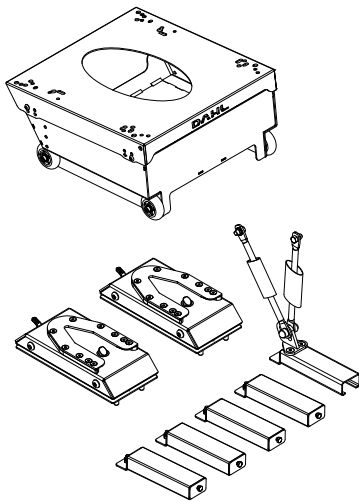

Art. No. 502288

GM Coachwork
Drop floor conversion:
VW Caravelle SE Colorado

Distribué en France et en Belgique par la Ste LENOIR Handi Concept

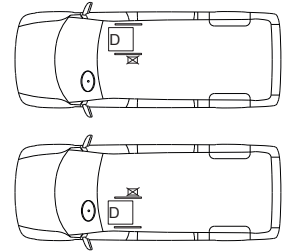
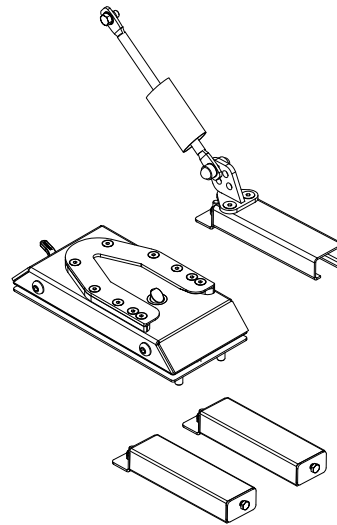

Art. No. 502368

Zawatzky Drop Floor
Conversion:
VW Centervan T6

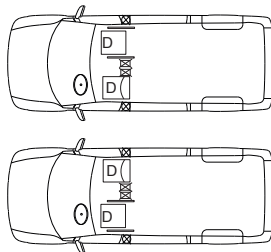
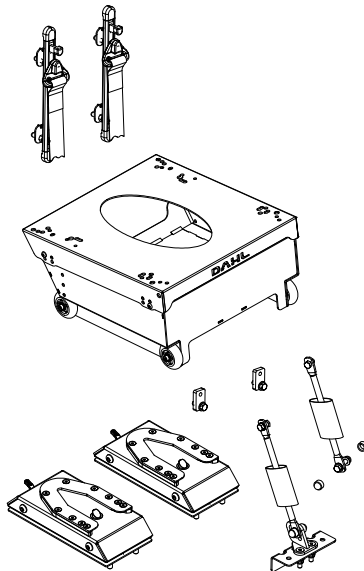

Art. No. 502369

Zawatzky Drop Floor
Conversion:
VW Centervan T6

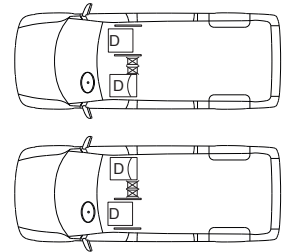
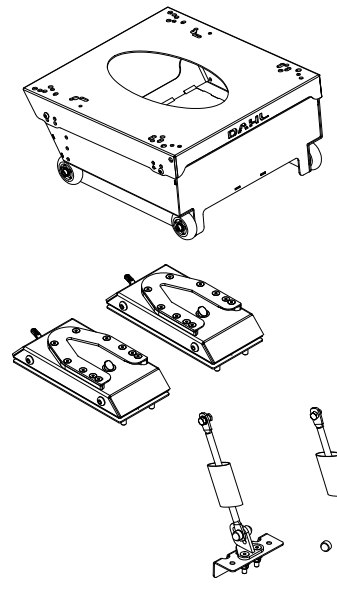

Art. No. 503120

Fiat Doblo
High roof SWB & LWB
Opel Combo
High roof SWB & LWB

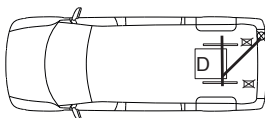
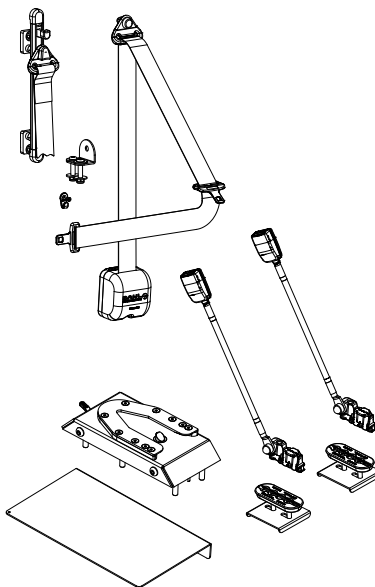

Art. No. 503121

Fiat Doblo
High roof SWB & LWB
Opel Combo
High roof SWB & LWB

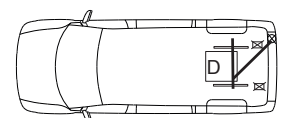
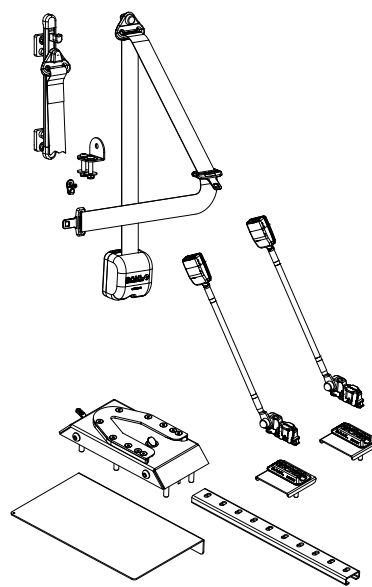

Kits d'installation pour la Station d'Arrimage Dahl MK II

Art. No. 503142

VW Crafter 2017-
MAN TGE 2017-

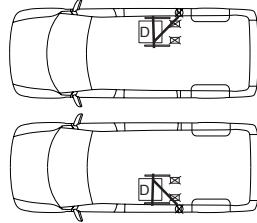
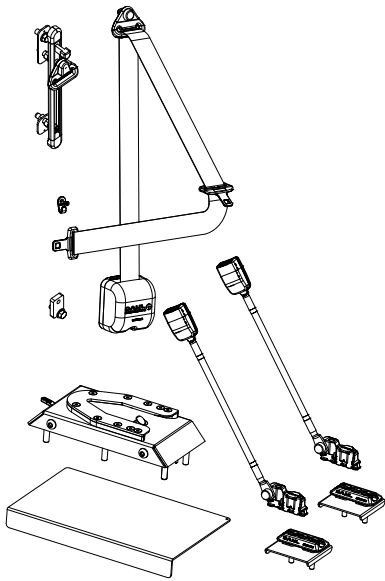

Art. No. 503143

VW Crafter 2017-
MAN TGE 2017-

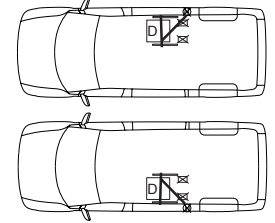
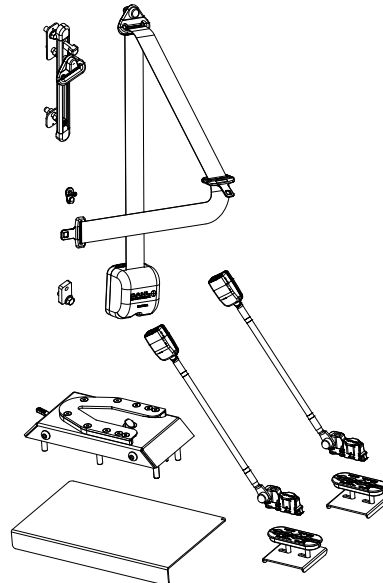

Art. No. 503144

VW Crafter 2017-
MAN TGE 2017-

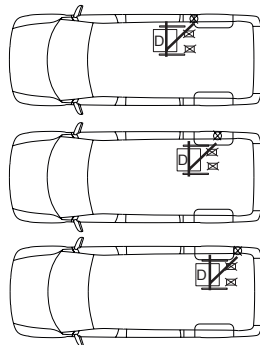
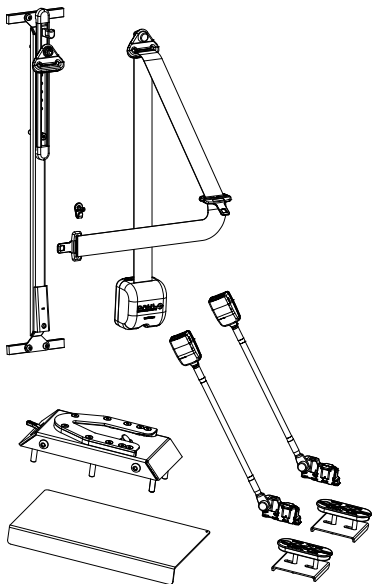

Art. No. 503145

VW Crafter 2017-
MAN TGE 2017-

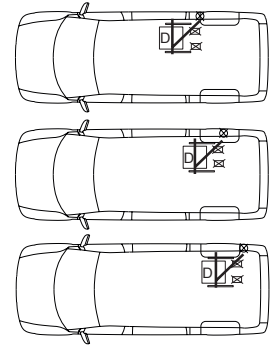
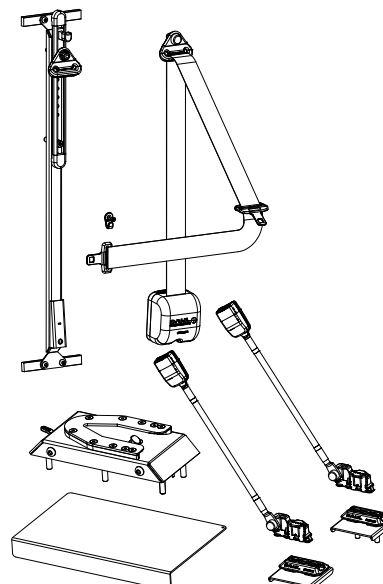

Art. No. 503197

Nissan NV 200

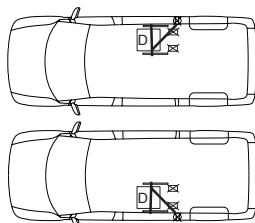
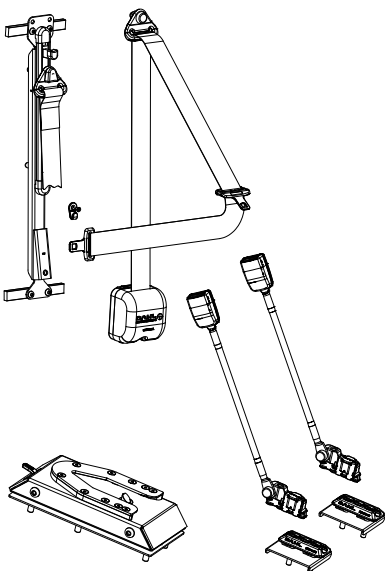

Art. No. 503301

Citroën Jumpy &
Spacetourer KO
Opel Zafira Life
Peugeot Expert &
Traveller KO
Toyota Proace &
Proace Verso 2016-

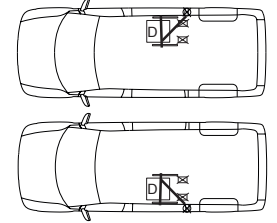
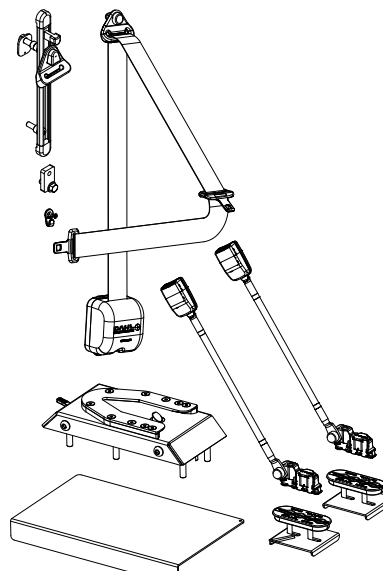

Kits d'installation pour la Station d'Arrimage Dahl MK II

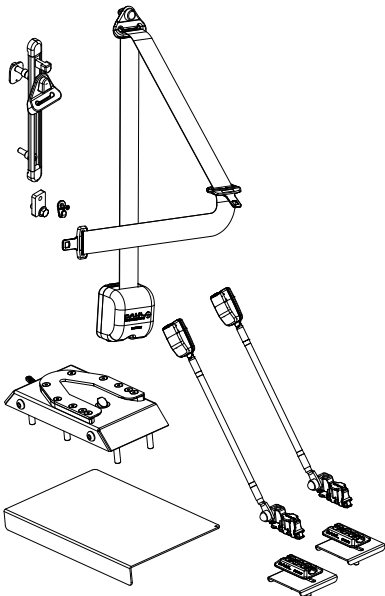

Art. No. 503302

Citroën Jumpy & Spacetourer KO
 Opel Zafira Life
 Peugeot Expert & Traveller KO
 Toyota Proace & Proace Verso 2016-

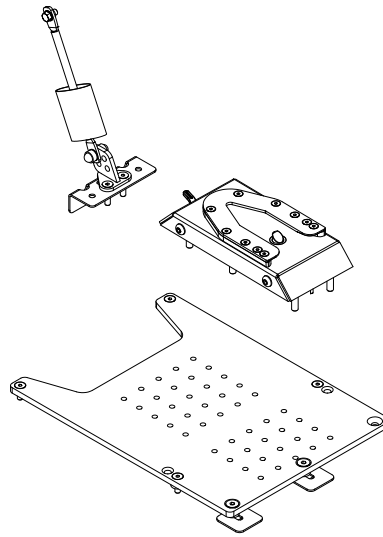
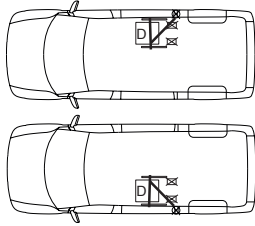

Art. No. 503303

Citroën Jumpy & Spacetourer KO
 Opel Zafira Life
 Peugeot Expert & Traveller KO
 Toyota Proace & Proace Verso 2016-

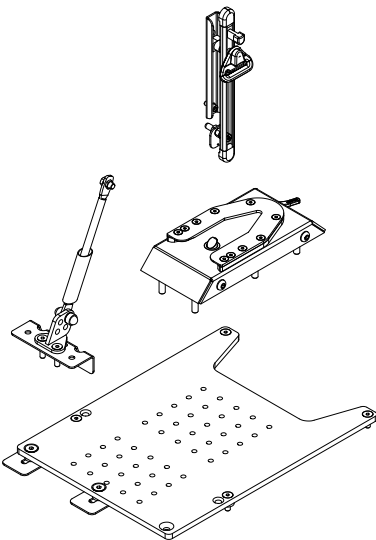
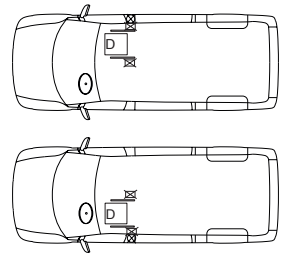

Art. No. 503304

Citroën Jumpy & Spacetourer KO
 Opel Zafira Life
 Peugeot Expert & Traveller KO
 Toyota Proace & Proace Verso 2016-

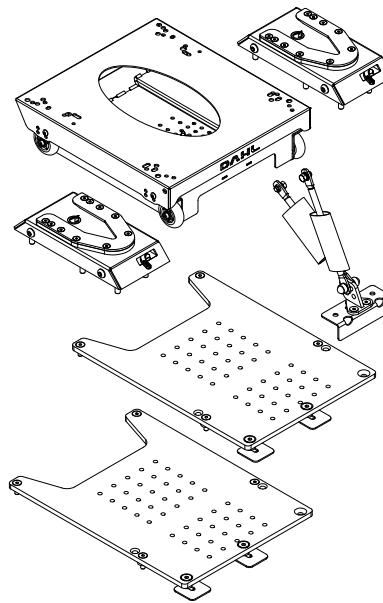
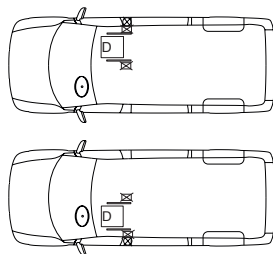

Art. No. 503305

Citroën Jumpy & Spacetourer KO
 Opel Zafira Life
 Peugeot Expert & Traveller KO
 Toyota Proace & Proace Verso 2016-

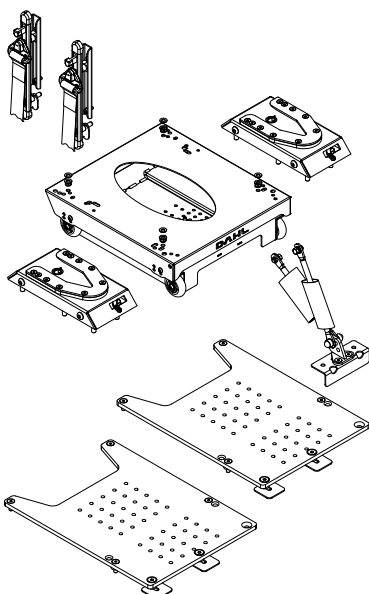
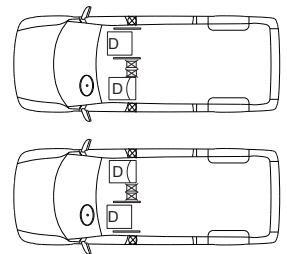

Art. No. 503306

Citroën Jumpy & Spacetourer KO
 Opel Zafira Life
 Peugeot Expert & Traveller KO
 Toyota Proace & Proace Verso 2016-

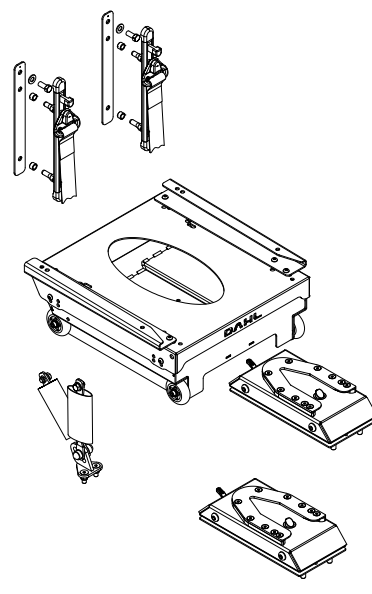
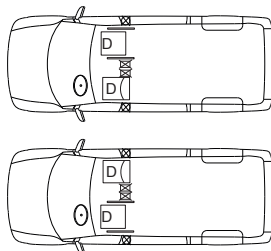

Art. No. 503255

ITEK Drop Floor Conversion:
 VW Caddy Active

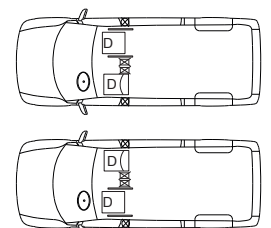

Kits d'installation pour la Station d'Arrimage Dahl MK II

Art. No. 503310

ITEK Drop Floor
Conversion:
VW Caddy Active

Art. No. 503461

Tripod/Allied Drop Floor
Conversion:
Citroën Berlingo
Peugeot Partner

Art. No. 503006

MB Vito
MB V-Class W447

Art. No. 503008

MB Vito
MB V-Class W447

Art. No. 500221 *

Ford Transit Custom V710
VW New Transporter /
Caravelle 2025-

FMVSS/CMVSS 210

Art. No. 500253 *

Ford Transit Custom V710
VW New Transporter /
Caravelle 2025-

FMVSS/CMVSS 210

* Voir aussi la liste de compatibilité à la page 10.

Kits d'installation pour la Station d'Arrimage Dahl MK II

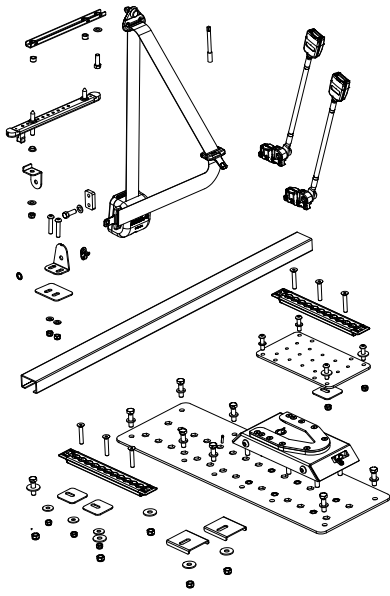

Art. No. 500254 *

Ford Transit Custom V710
VW New Transporter /
Caravelle 2025-

**FMVSS/CMVSS
210**

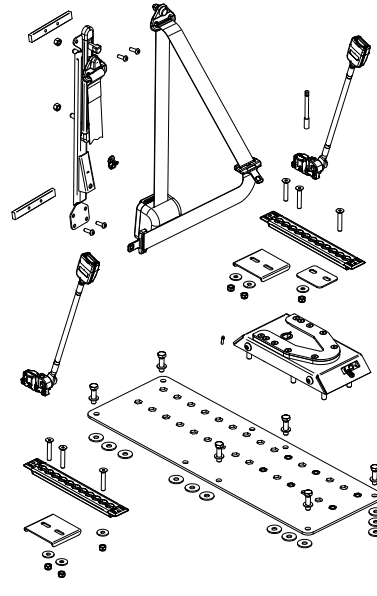
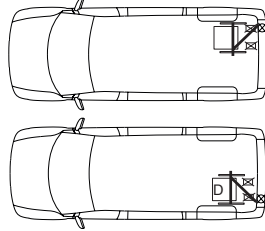

Art. No. 504063 *

Ford Transit Custom V710
VW New Transporter /
Caravelle 2025-

**FMVSS/CMVSS
210**

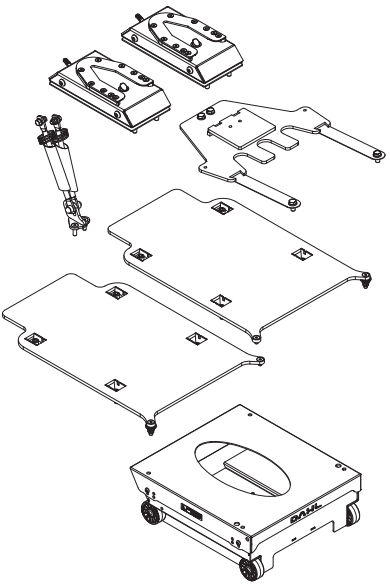
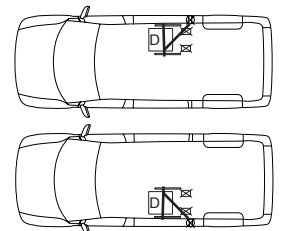

Art. No. 504144 *

Ford Transit Custom V710
VW New Transporter /
Caravelle 2025-

**FMVSS/CMVSS
207/210**

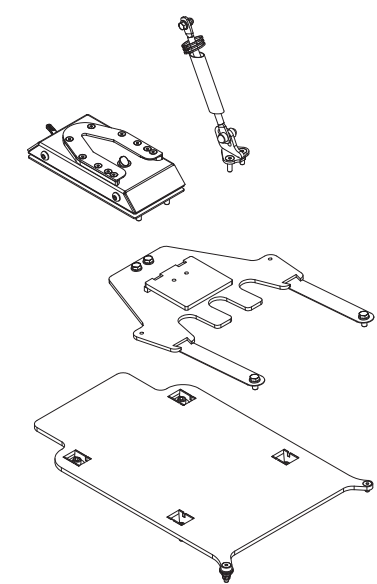
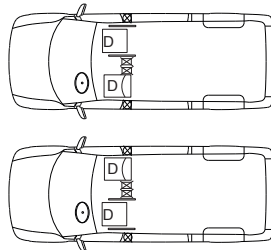

Art. No. 504149 *

Ford Transit Custom V710
VW New Transporter /
Caravelle 2025-

**FMVSS/CMVSS
207/210**

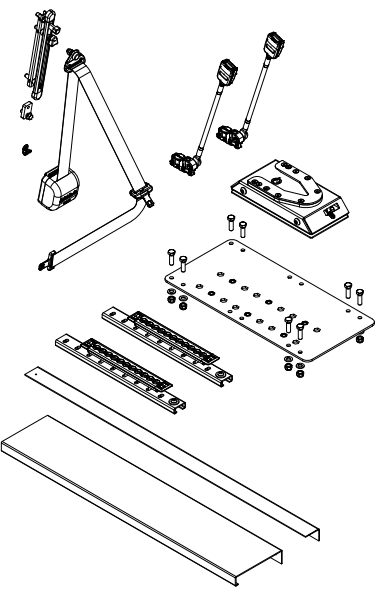
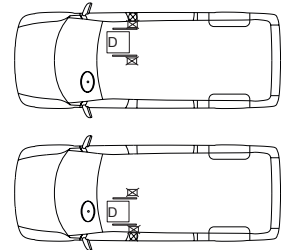

Art. No. 504157

Renault Master XDD
Nissan Interstar 2024-

**FMVSS/CMVSS
210**

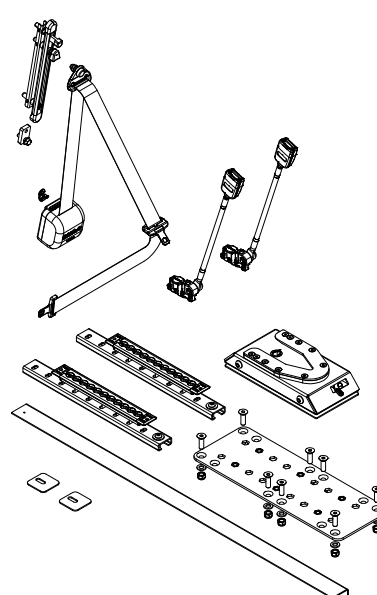
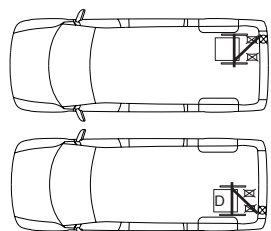

Art. No. 504162

Renault Master XDD
Nissan Interstar 2024-

**FMVSS/CMVSS
210**

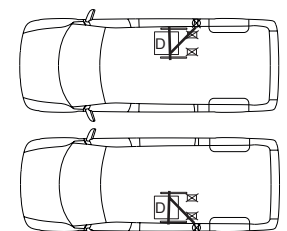

* Voir aussi la liste de compatibilité à la page 10.

Kits d'installation pour la Station d'Arrimage Dahl MK II

Art. No. 504167

Mercedes Sprinter
907/9710

FMVSS/CMVSS
210

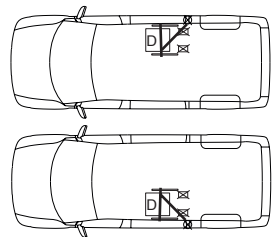
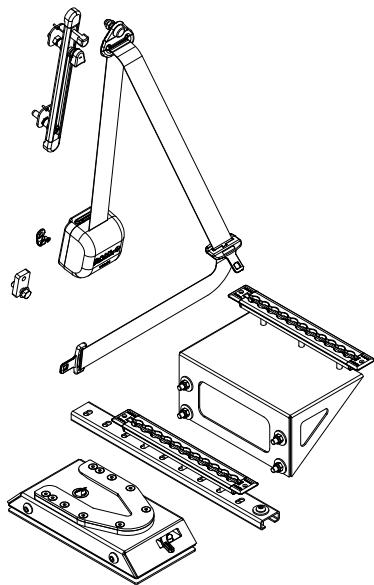

Art. No. 504169

Mercedes Sprinter
907/9710

FMVSS/CMVSS
210

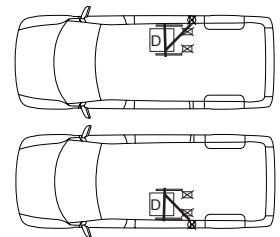
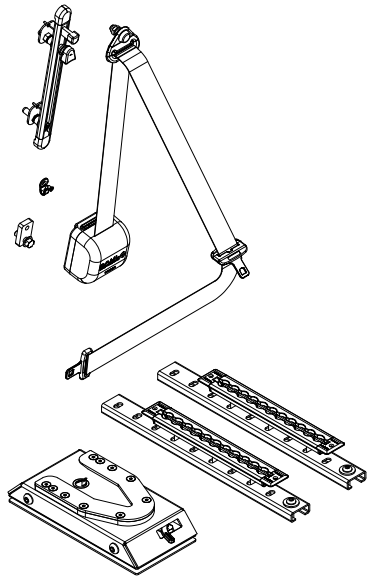

Liste des véhicules avec systèmes de retenue FR/UFR 4 points

Marque de véhicule	Modèle de véhicule	Position de l'ancrage de la ceinture épaulière	Type de montage sur plancher	Jusqu'à 85kg - CLASSIC Line	Jusqu'à 85 kg - EVOLUTION Line	Jusqu'à 200kg - HEAVY DUTY Line	FMVSS/CMVSS 210
Citroën	Berlingo Tripod/Allied Floor Conversion	RD			503463	503464	
	Jumper Y	C	surface	502057	503170	503135	
		C	flush	502058	503171	503488	
		W	surface	501945	503483		
		W	flush	501944	502111		
	right side	RD	surface		503736	503604	
	right side	RD	flush		503738	503624	
	left side	RD	surface		503739	503625	
	left side	RD	flush		503737	503605	
	Jumpy X	C	surface	502057	503170		
		C	flush	502058	503171		
		W	surface	501949	501057		
		W	flush	501948	501055		
		RD	surface	501771	503293		
		RD	flush	501799	503294		
	Space Tourer/Jumpy KO 2017-	C	surface		503296	503472	
		C	flush		503295	503474	
		RD	surface	501771	503293	503299	
	RD	flush	501799	503294	503300		
Space Tourer/Jumpy KO 2017 - Freedom Drop Floor Conversion	C (roof)	surface					
Fiat	Doblo High roof SWB&LWB	D	rail	502311	503312		
		D	rail	502317	501869		
		D	surface		502373	503560	
		D	flush		502372	503562	
	Ducato X250	C	surface	502057	503170	503135	
		C	flush	502058	503171	503488	
		W	surface	501945	503483		
		W	flush	501944	502111		
	right side	RD	surface		503736	503604	
	right side	RD	flush		503738	503624	
	left side	RD	surface		503739	503625	
	left side	RD	flush		503737	503605	
	Scudo X270	C	surface	502057	503170		
		C	flush	502058	503171		
		W	surface	501949	501057		
		W	flush	501948	501055		
		RD	surface	501771	503293		
		RD	flush	501799	503294		
Talento	C	surface	502057	503170	503135		
	C	flush	502058	503171	503488		
	D	surface	502057	503170	503135		
	D	flush	502058	503171	503488		
Ford	Transit Custom V362	C	surface	502057	503170		
		C	flush	502058	503171		
		W	surface	501947	503486	503135	
		W	flush	501946	503487	503488	
		D	surface	502057	503170	503135	
		D	flush	502058	503171	503488	
		RD	surface	501771	503293		
		RD	flush	501799	503294		
	Transit V363	C	surface	502056	501054		
		C	flush	502055	501053		
		W	surface	502060	501051		
		W	flush	502059	501050		
		D	surface	502057	503170		
		D	flush	502058	503171		
Transit Custom V710	VOIR LA LISTE À LA PAGE 42 POUR PLUS D'INFORMATIONS.						
MAN	TGE 2017-	C	surface	503162	503133	503496	
		C	flush	503163	503131	503493	
		W	surface	503164	503132	503494	
		W	flush	503163	503130	503495	
		D	surface	502057	503170	503135	
		D	flush	502058	503171	503488	
		RD	surface		500114	500118	
Mercedes	Sprinter 906 & 907 & 910	C	surface	502057	503170	503135	✓
		C	flush	502058	503171	503488	✓
		W	surface	501679	503482	500826	✓
		W	flush	501932	503484	500827	✓
		D	surface	502057	503170	503135	✓
		D	flush	502058	503171	503488	✓
		RD	surface		500114	500118	✓
	RD	flush		500115	500119	✓	

Symboler: Pied de caisse milieu = C / Pied de caisse arrière = D / Encadrement vitre = W / Porte arrière = RD
 Ancrage plot de surface = surface / Ancrage en insertion = flush / Rail de plancher = rail

Liste des véhicules avec systèmes de retenue FR/UFR 4 points

Marque de véhicule	Modèle de véhicule	Position de l'ancrage de la ceinture épaulière	Type de montage sur plancher	Jusqu'à 85kg - CLASSIC Line	Jusqu'à 85 kg - EVOLUTION Line	Jusqu'à 200kg - HEAVY DUTY Line	FMVSS/CMVSS 210
Mercedes	Sprinter 906 & 907 High roof, wheel base 3250-3665-4325	W	surface	502063	500726		
		W	flush	502062	500729		
	Vito & V-Class W447	W	surface	502241	503485		
		W	flush	502239	503524		
		RD	surface	501771	503293		
		RD	flush	501799	503294		
	Vito 639 & V-Class W447	C	surface	502057	503170	503135	
		C	flush	502058	503171	503488	
		W	surface	501821	501789		
		RD	surface	501771	503293	503299	
	RD	flush	501799	503294	503300		
	RD	surface		503358			
	RD	flush		503357			
Nissan	Nissan Interstar 2024-	C	surface		504204		√
		C	flush		504203		√
		W	surface		504198		√
		W	flush		504183		√
		D	surface		504165		√
		D	flush		504173	504249	√
		RD	surface		504177		√
		RD	flush		504181		√
	Nissan NV 200	W	surface	501947	503486		
		W	flush	501946	503487		
		RD	surface		503187		
	Nissan NV 300	C	surface	502057	503170	503135	
		C	flush	502058	503171	503488	
		D	surface	502057	503170	503135	
		D	flush	502058	503171	503488	
	Nissan NV400	C	surface	502057	503170	503135	
		C	flush	502058	503171	503488	
		W	surface	501942	501885		
		W	flush	501943	501886		
		D	surface	502057	503170	503135	
	D	flush	502058	503171	503488		
Nissan Primastar	C	surface	502057	503170			
	C	flush	502058	503171			
	D	surface	502057	503170			
	D	flush	502058	503171			
Opel	Combo High roof SWB&LWB	D	surface		502373	503560	
		D	flush		502372	503562	
		D	rail	502311	503312		
		D	rail	502317	501869		
	Movano X62	W	surface	501942	501885		
		W	flush	501943	501886		
		C	surface	502057	503170	503135	
		C	flush	502058	503171	503488	
		D	surface	502057	503170	503135	
		D	flush	502058	503171	503488	
	Vivaro X82	C	surface	502057	503170	503135	
		C	flush	502058	503171	503488	
		D	surface	502057	503170	503135	
		D	flush	502058	503171	503488	
	Vivaro X83	C	surface	502057	503170	503135	
		C	flush	502058	503171	503488	
		D	surface	502057	503170	503135	
	D	flush	502058	503171	503488		
Zafira Life	C	surface		503296	503472		
	C	flush		503295	503474		
	RD	surface	501771	503293	503299		
	RD	flush	501799	503294	503300		
Zafira Life - Freedom drop floor conversion	C (roof)	surface					
Peugeot	Boxer Y	C	surface	502057	503170	503135	
		C	flush	502058	503171	503488	
		W	surface	501945	503483		
		W	flush	501944	502111		
	right side	RD	surface		503736	503604	
	right side	RD	flush		503738	503624	
	left side	RD	surface		503739	503625	
	left side	RD	flush		503737	503605	
	Expert X	C	surface	502057	503170		
		C	flush	502058	503171		
		W	surface	501949	501057		
		W	flush	501948	501055		
		RD	surface	501771	503293		
		RD	flush	501799	503294		
	Partner Tripod/Allied floor conversion	D	surface		503463	503464	
	Traveller/Expert KO 2017-	C	surface		503296	503472	
		C	flush		503295	503474	
		RD	surface	501771	503293	503299	
	RD	flush	501799	503294	503300		
Traveller/Expert KO 2017- Freedom Drop Floor Conversion	C (roof)	surface					

Liste des véhicules avec systèmes de retenue FR/UFR 4 points

Marque de véhicule	Modèle de véhicule	Position de l'ancrage de la ceinture épaulière	Type de montage sur plancher	Jusqu'à 85kg - CLASSIC Line	Jusqu'à 85 kg - EVOLUTION Line	Jusqu'à 200kg - HEAVY DUTY Line	FMVSS/CMVSS 210	
Renault	Master X62	C	surface	502057	503170	503135		
		C	flush	502058	503171	503488		
		W	surface	501942	501885			
		W	flush	501943	501886			
		D	surface	502057	503170	503135		
		D	flush	502058	503171	503488		
	Trafic X82	C	surface	502057	503170	503135		
		C	flush	502058	503171	503488		
		D	surface	502057	503170	503135		
		D	flush	502058	503171	503488		
	Trafic X83	C	surface	502057	503170	503135		
		C	flush	502058	503171	503488		
		D	surface	502057	503170	503135		
		D	flush	502058	503171	503488		
	Master XDD 2024-	C	surface		504204		√	
		C	flush		504203		√	
		W	surface		504198		√	
		W	flush		504183		√	
D		surface		504165		√		
D		flush		504173	504249	√		
Toyota	Proace	C	surface	502057	503170			
		C	flush	502058	503171			
		W	surface	501949	501057			
		W	flush	501948	501055			
		RD	surface	501771	503293			
		RD	flush	501799	503294			
	ProAce/Verso 2017-	C	surface		503296	503472		
		C	flush		503295	503474		
		RD	surface	501771	503293	503299		
		RD	flush	501799	503294	503300		
	ProAce/Verso 2017- Freedom Drop Floor Conversion	C (roof)	surface					
	VW	Caddy, ITEK drop floor conversion Crafter (2006-2016)	RD	surface		503239		
			W	surface	501679	503482	500826	
			W	flush	501932	500814	500827	
			D	surface	502057	503170		
			D	flush	502058	503171		
			RD	surface		500114	500118	
			RD	flush		500115	500119	
Crafter (2006-2016) High Roof, Wheel base 3250-3665-4325			W	surface	502063	500726		
		W	flush	502062	500729			
Crafter 2017-		C	surface	503162	503133	503496		
		C	flush	503163	503131	503493		
		W	surface	503164	503132	503494		
		W	flush	503165	503130	503495		
		D	surface	502057	503170	503135		
		D	flush	502058	503171	503488		
		RD	surface		500114	500118		
		RD	flush		500115	500119		
New Transporter / Caravelle 2025-T5 & T6		VOIR LA LISTE À LA PAGE 42 POUR PLUS D'INFORMATIONS.						
	C	surface	502057	503170	503135			
	C	flush	502058	503171	503488			
	W	surface	501774	501772				
	W	flush	501786	501773				
	D	surface		503170	503135			
	D	flush		503171	503488			
	RD	surface	501771	503293	503299			
	RD	flush	501799	503294	503300			
	RD	surface		503352				
	RD	flush		503353				
	T5 & T6 Multivan, original floor rails	RD	surface		503122	503498		

Explication des symboles des kits avec 4 points d'ancrage WTORS

Console ou rail au sol pour installation en surface

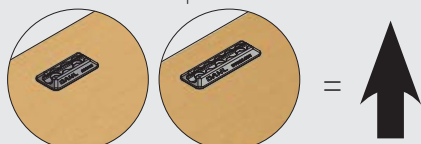

Console ou rail au sol pour installation encastrée

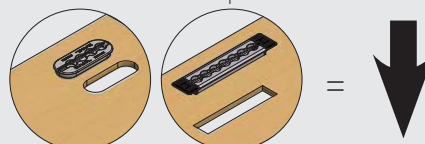

Pied de caisse milieu = C / Pied de caisse arrière = D / Encadrement vitre = W / Porte arrière = RD / Ancrage plot de surface = surface / Ancrage en insertion = flush / Rail de plancher = rail

Liste de compatibilité

Position de l'épaule ancrage de la ceinture	Trappe de plancher type	N° d'article du kit 4 points Gamme EVOLUTION - 85 kg	N° d'article du kit 4 points Gamme HEAVY DUTY - 200 kg	Type de propulsion Compatibilité			Dimensions de la camionnette Compatibilité				Style de carrosserie Compatibilité			FMVSS/CMVSS 210		
				BEV	PHEV	ICE	L1	L2	H1	H2	Van	Kombi	Bus			
rangée de sièges 2, cadre de la vitre latérale arrière	surface	500248		√	√	√	√	√	√	√	√	-	√	√	√	
		504058		-	-	√	√	√	√	√	√	√	√	√	√	
	flush	500247			√	√	√	√	√	√	√	√	√	√	√	√
		504060			-	-	√	√	√	√	√	√	√	√	√	√
		504059			-	-	√	√	√	√	√	√	√	√	√	√
		500251	504282	√	√	√	√	√	√	√	√	-	√	√	√	√
rangée de sièges 3, Montant D	surface	504055	504284	-	-	√	√	√	√	√	√	√	√	√	√	
		500252	504283	√	√	√	√	√	√	√	-	√	√	√	√	
	flush	504056	504279	-	-	√	√	√	√	√	√	√	√	√	√	√
		504057		-	-	√	√	√	√	√	√	√	√	√	√	√
		500223	504280	√	√	√	√	√	√	√	-	-	√	√	√	√
		504115		-	-	√	√	√	√	√	√	√	√	√	√	√
rangée de sièges 3, ouverture supérieure de la porte arrière	surface														√	
		500224	504281	√	√	√	√	√	√	-	-	√	√	√	√	
	flush	504137		-	-	√	√	√	√	√	√	-	√	√	√	√

* BEV = Battery Electric Vehicle

* PHEV = Plug-In Hybrid Electric Vehicle

* ICE = Internal Combustion Engine

Consultez également les schémas des véhicules dans le chapitre suivant.

«Ligne CLASSIC» – jusqu'à 85 kg

La «ligne CLASSIC» est notre première génération de sangle d'arrimage rétractable, caractérisée par un beau design et une haute qualité.



- Le boîtier du rétracteur est moulé en métal
- Belle surface métallique argentée
- Molette des deux côtés pour tendre les sangles
- Bouton-poussoir de déverrouillage

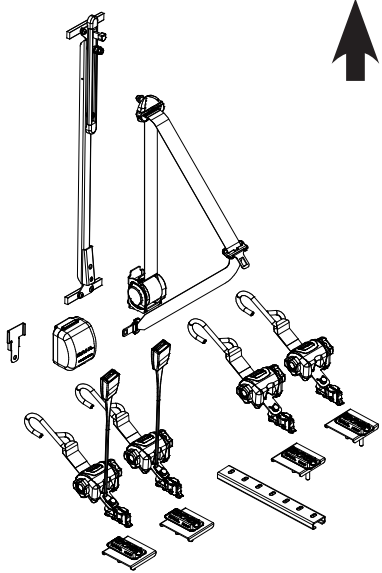

Art. No. 501679

MB Sprinter
906 & 907 & 910
VW Crafter (2006-2016)

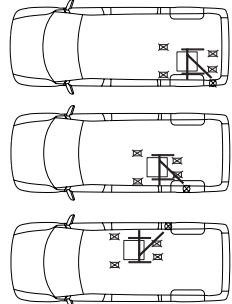
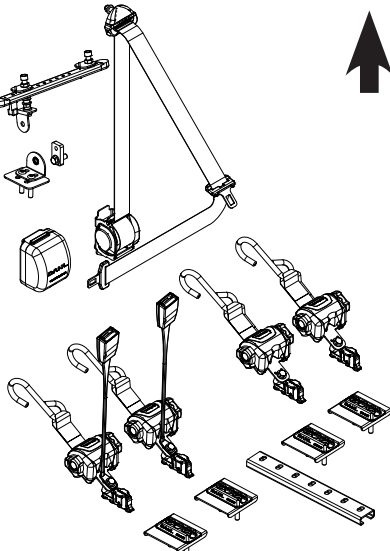

Art. No. 501771

Citroën Jumpy X
Citroën Space Tourer / Jumpy KO 2016-
Fiat Scudo X270
Ford Transit Custom V362
MB Vito 639 & V-Class W447
Opel Zafira Life
Peugeot Expert X
Peugeot Traveller / Expert KO 2016-
Toyota Proace / Verso 2016-
VW T5 & T6

Art. No. 501774

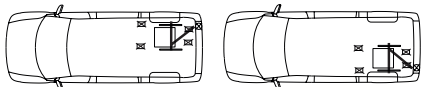
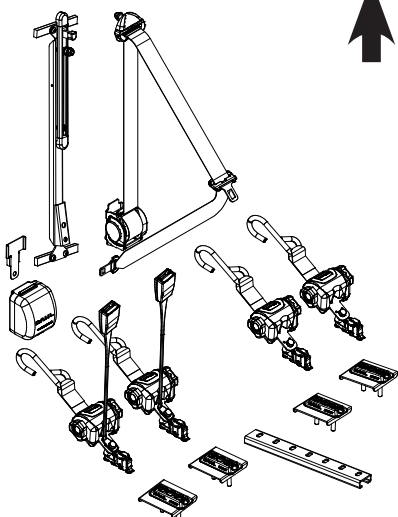
VW T5 & T6

Art. No. 501786

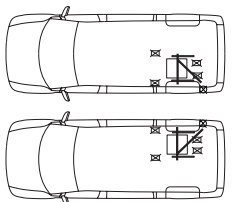
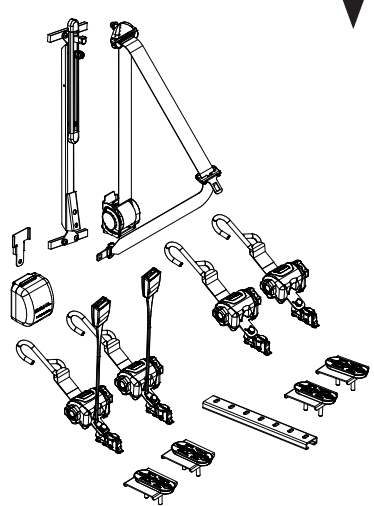
VW T5 & T6

Art. No. 501799

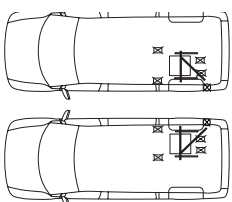
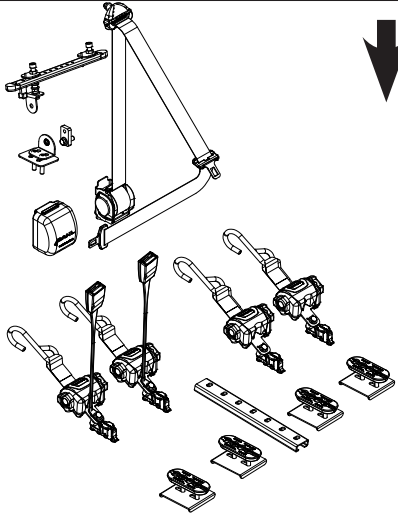
Citroën Jumpy X
Citroën Space Tourer / Jumpy KO 2016-
Fiat Scudo X270
Ford Transit Custom V362
MB Vito 639 & V-Class W447
Opel Zafira Life
Peugeot Expert X
Peugeot Traveller / Expert KO 2016-
Toyota Proace / Verso 2016-
VW T5 & T6



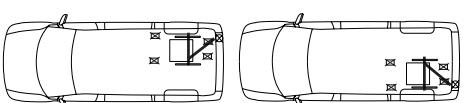
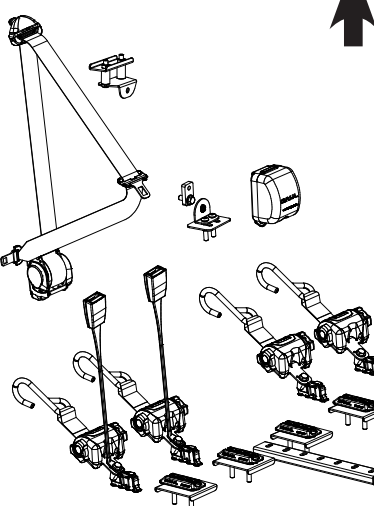

Art. No. 501821

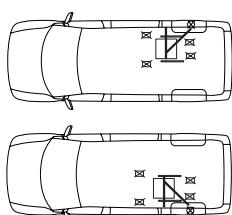
MB Vito 639 & V-Class W447



↓

Art. No. 501932
MB Sprinter 906 & 907 & 910 VW Crafter (2006-2016)

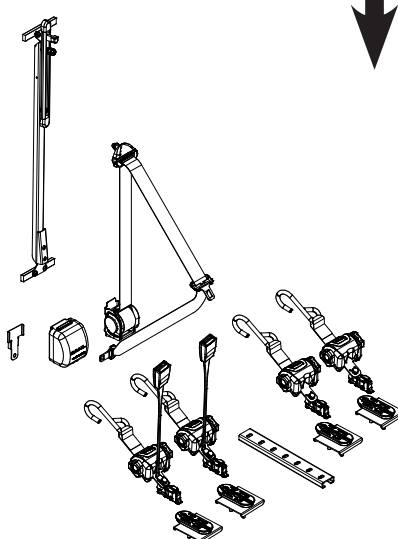
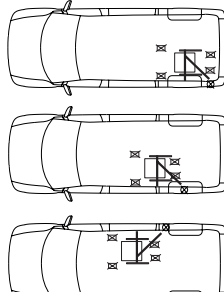
↑

Art. No. 501942
Opel Movano X62 L1, L2, L3, L4 Renault Master X62 L1, L2, L3, L4 Nissan NV400 L1, L2, L3, L4

↓

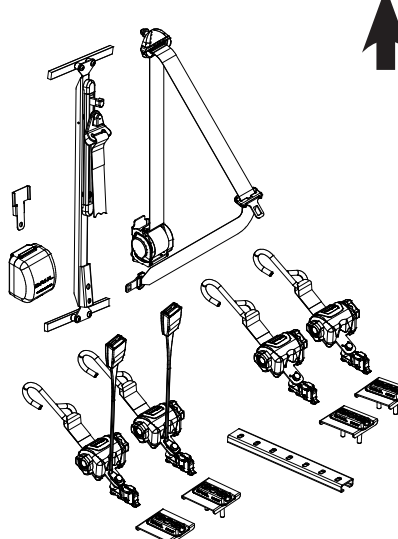
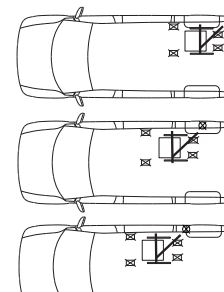
Art. No. 501943
Opel Movano X62 L1, L2, L3, L4 Renault Master X62 L1, L2, L3, L4 Nissan NV400 L1, L2, L3, L4

↓

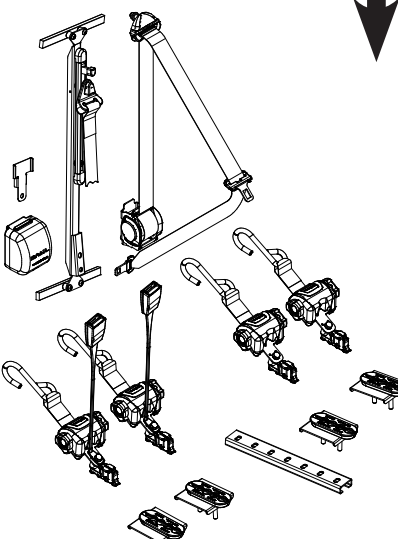
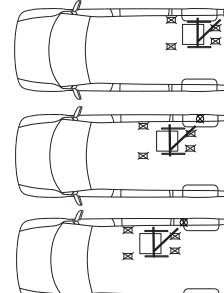
Art. No. 501944
Fiat Ducato X250 Peugeot Boxer Y Citroën Jumper Y

↑

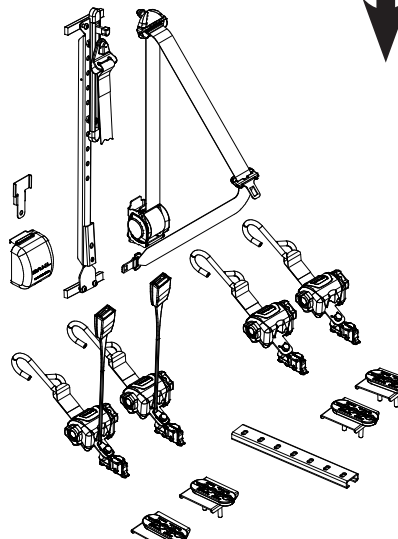
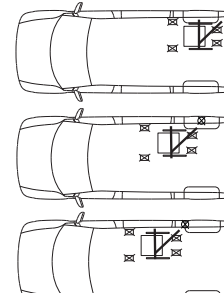
Art. No. 501945
Fiat Ducato X250 Peugeot Boxer Y Citroën Jumper Y

↓

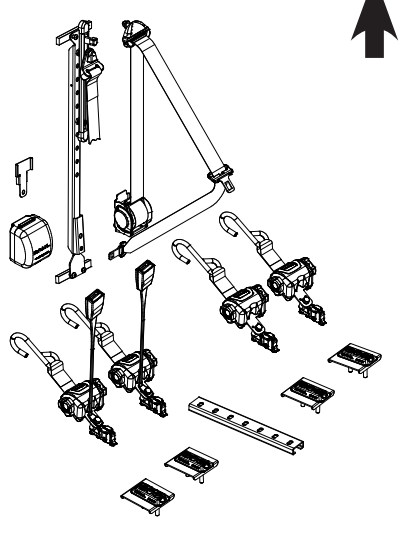
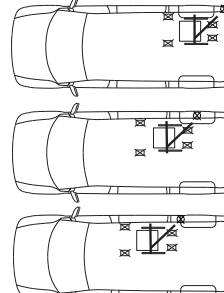
Art. No. 501946
Ford Transit Custom V362 Nissan NV 200



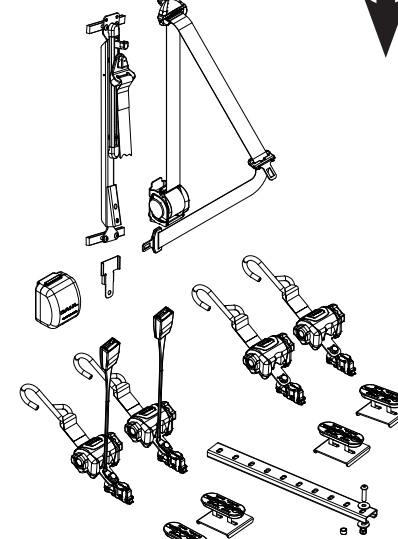
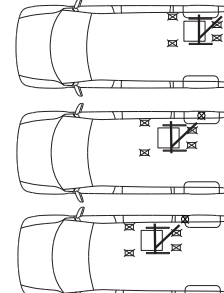

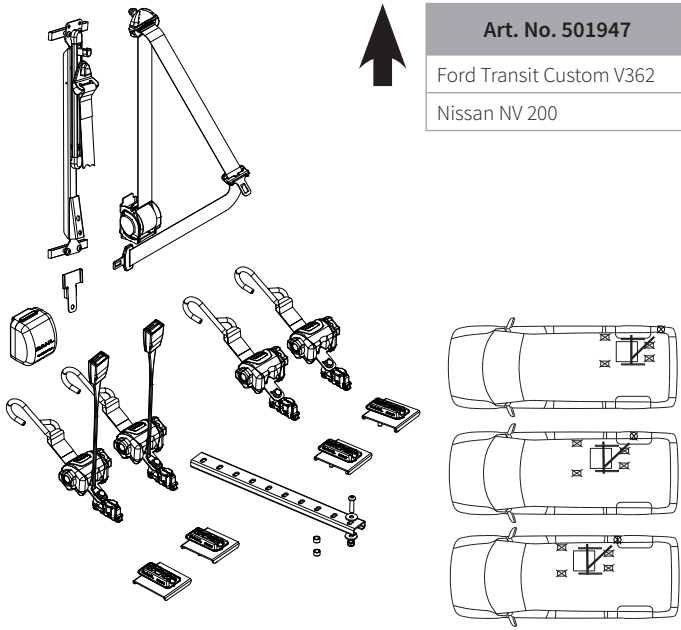

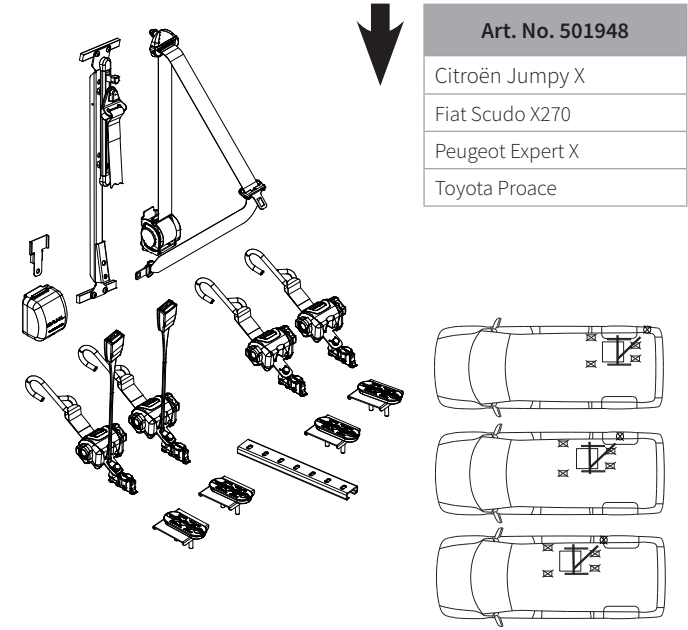
Art. No. 501947
 Ford Transit Custom V362
 Nissan NV 200

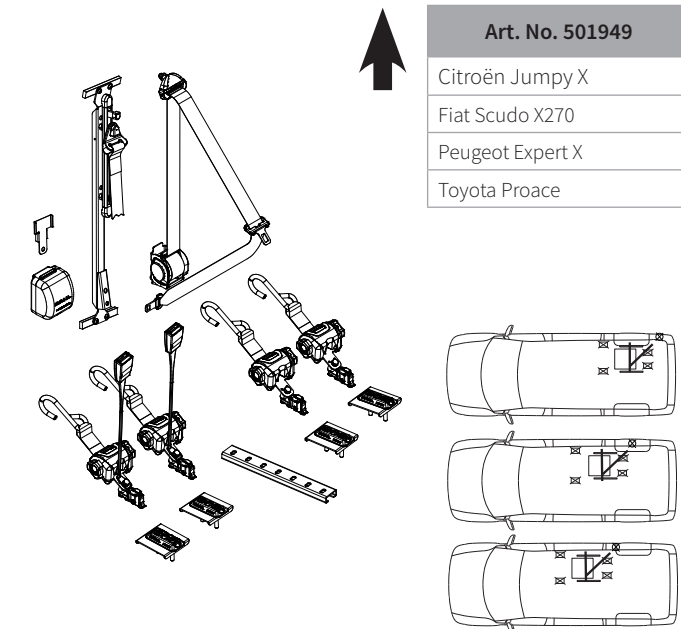

Art. No. 501948
 Citroën Jumpy X
 Fiat Scudo X270
 Peugeot Expert X
 Toyota Proace



Art. No. 501949
 Citroën Jumpy X
 Fiat Scudo X270
 Peugeot Expert X
 Toyota Proace

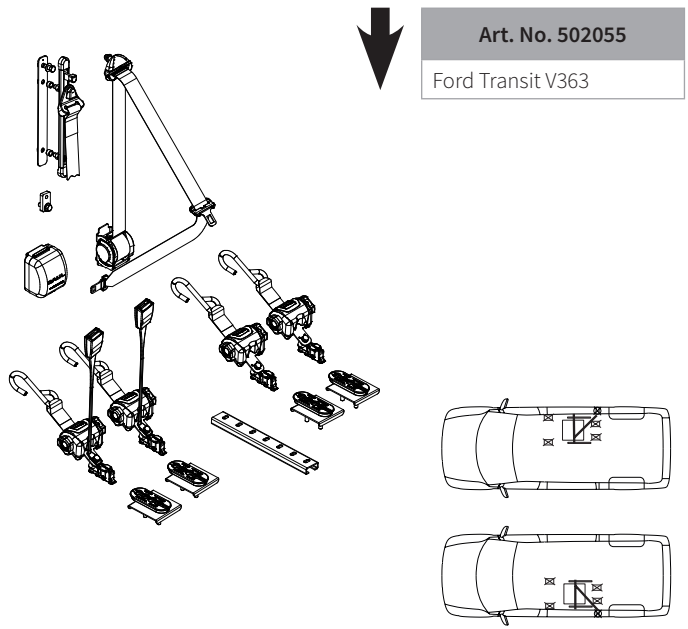

Art. No. 502055
 Ford Transit V363

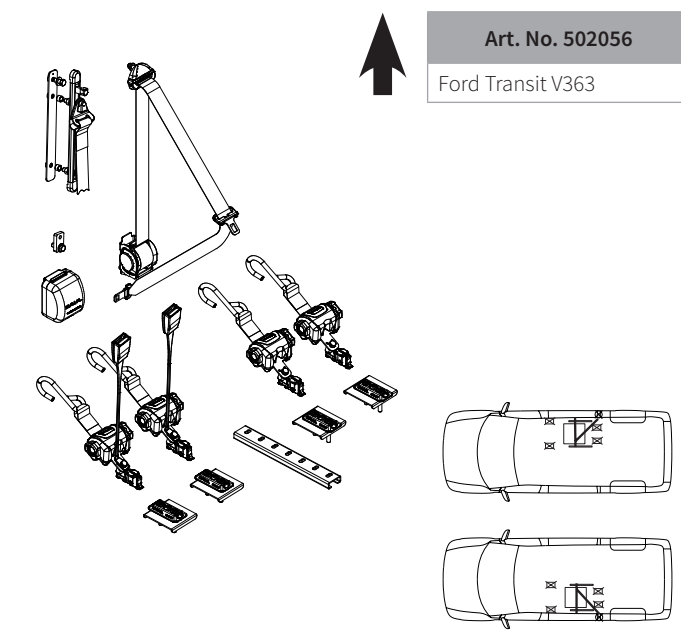

Art. No. 502056
 Ford Transit V363

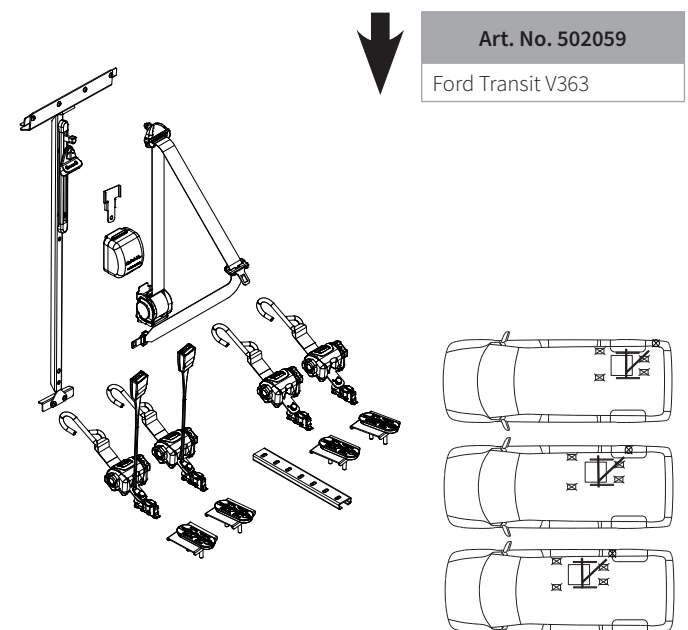

Art. No. 502059
 Ford Transit V363

Art. No. 502057
Fiat Talento
Ford Transit V363
Ford Transit Custom V362
MAN TGE 2017-
MB Sprinter 906 & 907 & 910
Nissan Primastar
Nissan NV300
Nissan NV400
Opel Vivaro X82 & X83
Opel Movano X62
Renault Master X62
Renault Trafic X82 & X83
VW Crafter (2006-2016)
VW Crafter 2017-

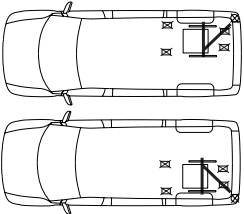

Art. No. 502057
Citroën Jumper Y
Citroën Jumpy X
Fiat Ducato X250
Fiat Scudo X270
Fiat Talento
Ford Transit Custom V362
MB Sprinter 906 & 907 & 910
MB Vito 639 & W447
Nissan NV300
Nissan NV400 L1, L2, L3, L4
Nissan Primastar
Opel Movano X62 L1, L2, L3, L4
Opel Vivaro X82 & X83
Peugeot Boxer Y
Peugeot Expert X
Renault Master X62 L1, L2, L3, L4
Renault Trafic X82 & X83
Toyota Proace
VW T5 & T6

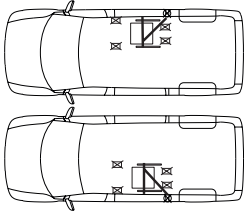

Art. No. 502058
Fiat Talento
Ford Transit V363
Ford Transit Custom V362
MAN TGE 2017-
MB Sprinter 906 & 907 & 910
Nissan Primastar
Nissan NV300
Nissan NV400
Opel Vivaro X82 & X83
Opel Movano X62
Renault Master X62
Renault Trafic X82 & X83
VW Crafter (2006-2016)
VW Crafter 2017-

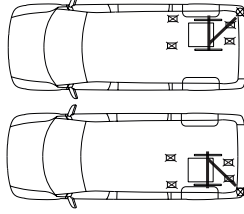

Art. No. 502058
Citroën Jumper Y
Citroën Jumpy X
Fiat Ducato X250
Fiat Scudo X270
Fiat Talento
Ford Transit Custom V362
MB Sprinter 906 & 907 & 910
MB Vito 639 & W447
Nissan NV400 L1, L2, L3, L4
Nissan NV300
Nissan Primastar
Opel Movano X62 L1, L2, L3, L4
Opel Vivaro X82 & X83
Peugeot Boxer Y
Peugeot Expert X
Renault Master X62 L1, L2, L3, L4
Renault Trafic X82 & X83
Toyota Proace
VW T5 & T6

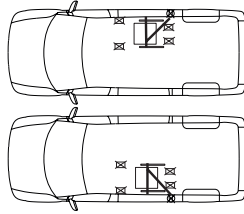
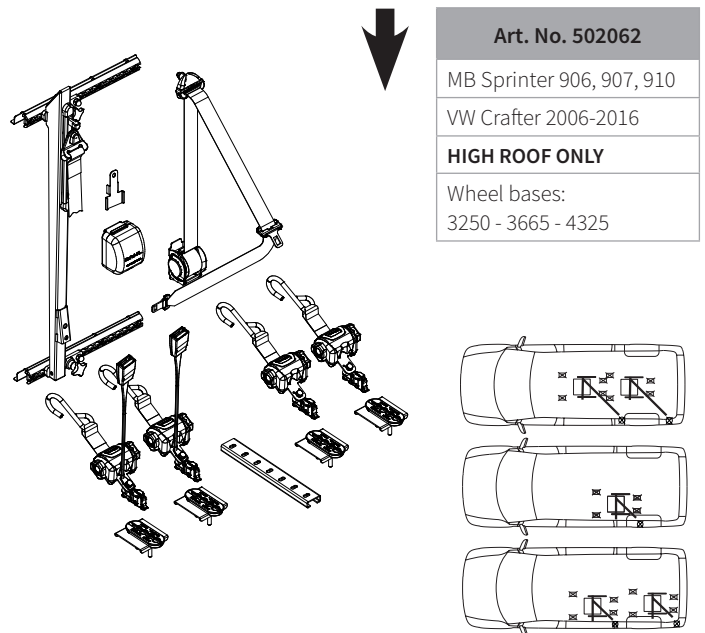
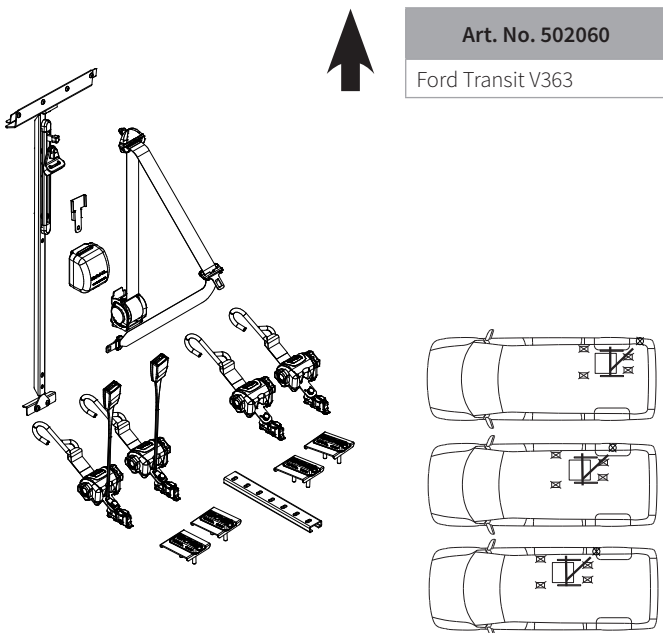
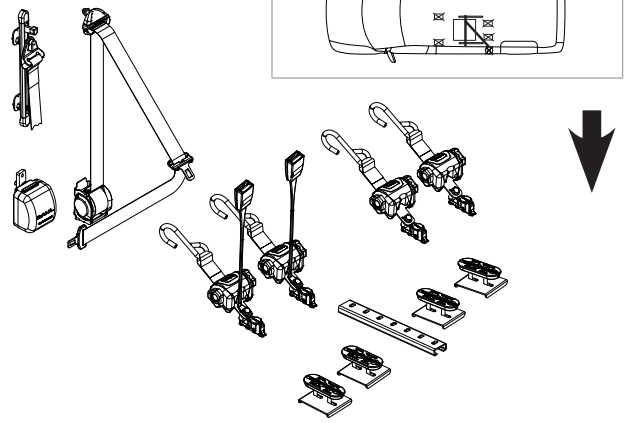
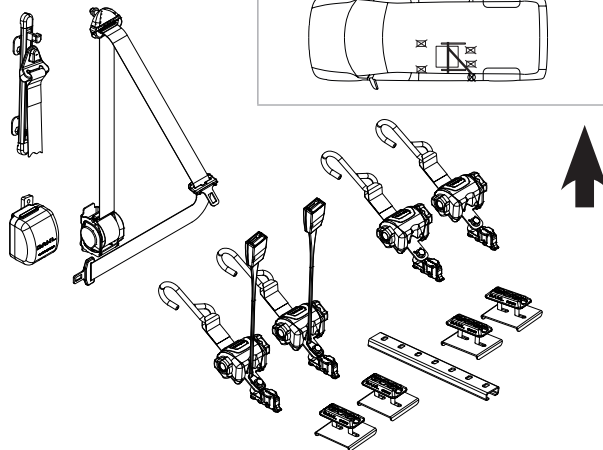
Art. No. 502063

MB Sprinter 906, 907, 910

VW Crafter 2006-2016

High roof only:

Wheel bases:
3250 - 3665 - 4325

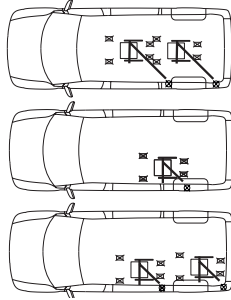
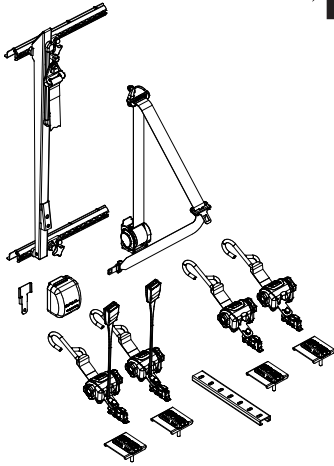

Art. No. 502239

MB Vito & V-Class W447

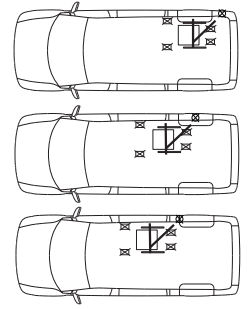
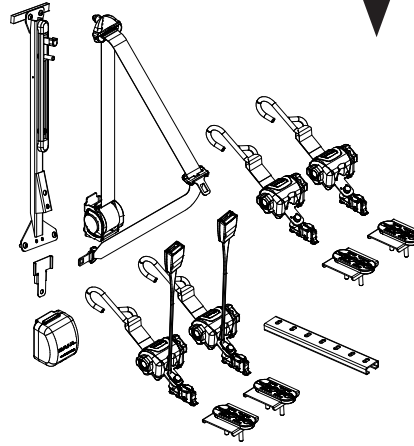

Art. No. 502241

MB Vito & V-Class W447

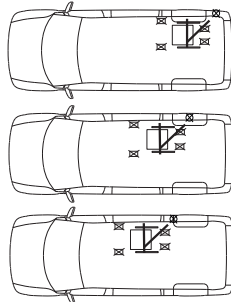
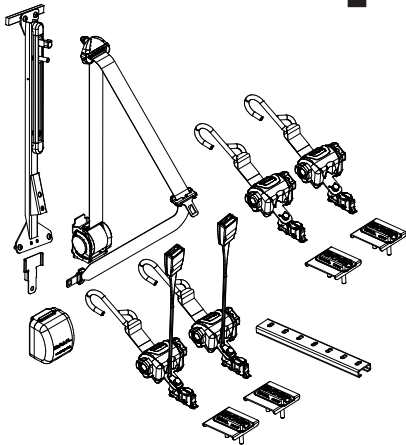

Art. No. 502311

Fiat Doblo
High roof SWB & LWB

Opel Combo
High roof SWB & LWB

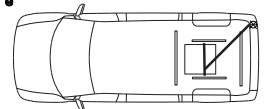
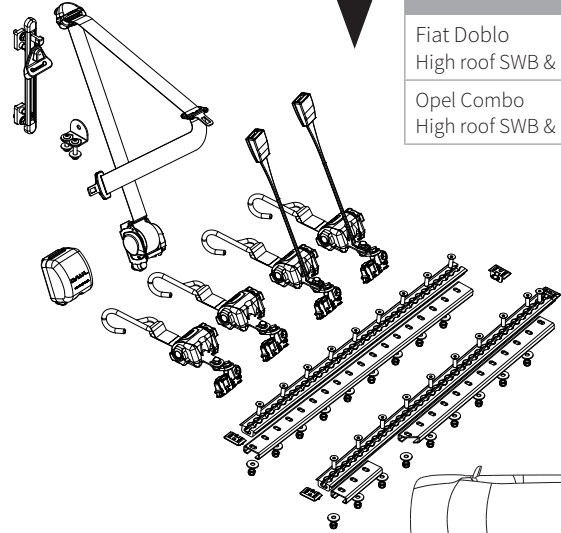

Art. No. 502317

Fiat Doblo
High roof SWB & LWB

Opel Combo
High roof SWB & LWB

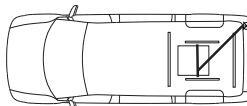
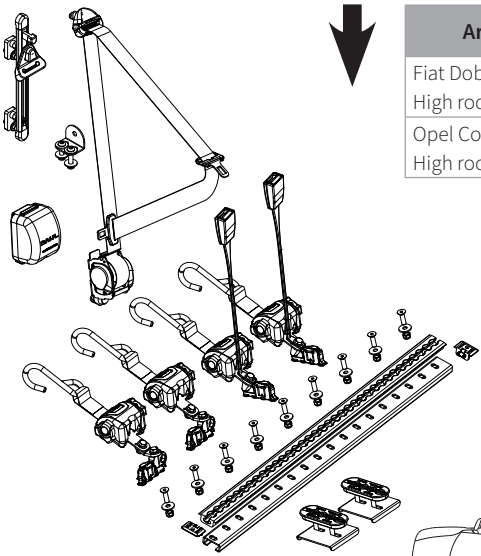

Art. No. 503162

VW Crafter 2017-

Man TGE 2017-

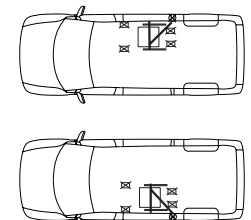
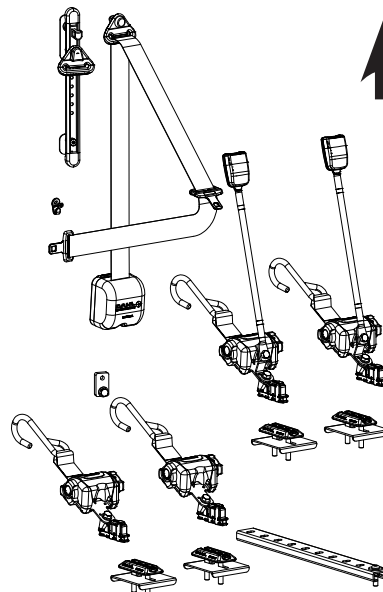

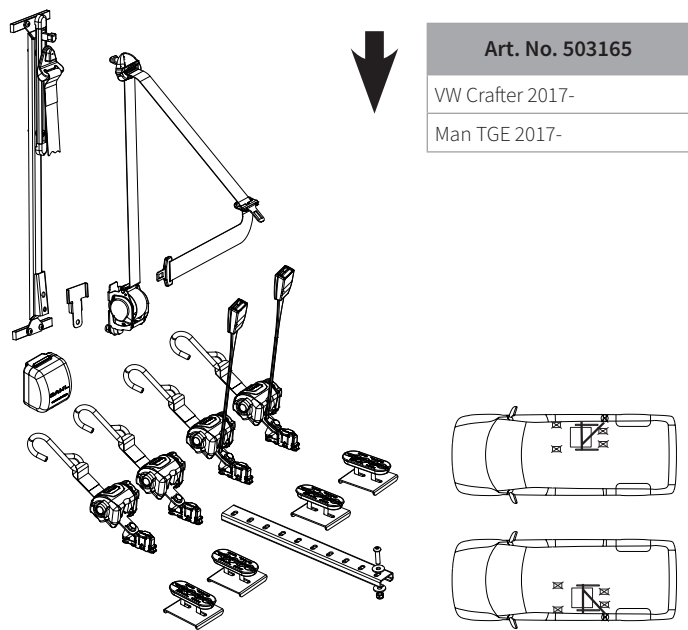
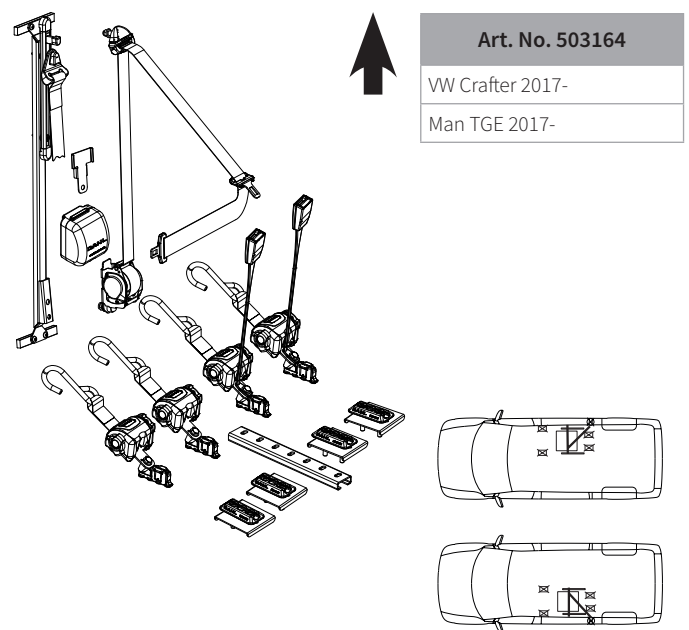
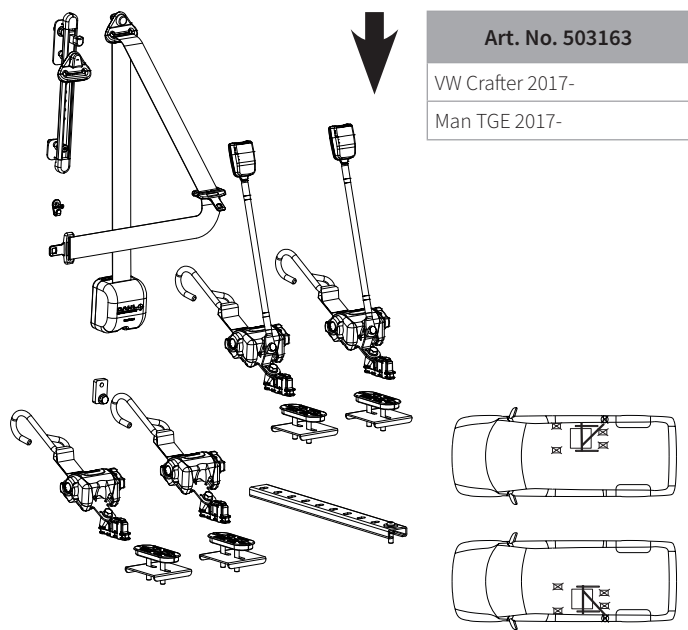

«Ligne EVOLUTION» – jusqu'à 85 kg

La «ligne EVOLUTION» est un développement innovant qui met l'accent sur le design moderne, la durabilité et la légèreté sans compromettre la qualité ou la robustesse.

En utilisant de nouveaux matériaux de meilleure qualité, nous avons réussi à réduire le poids de 27% par rapport à un rétracteur de «ligne Classic» équivalent, tout en égalant, voir en surpassant, les paramètres de qualité de la «ligne Classic». Cela peut être particulièrement utile dans les véhicules, où le poids est un facteur crucial.



- Le boîtier du rétracteur est moulé dans un plastique incassable avec une belle finition mate
- La résistance à la rupture a été testée à des températures allant jusqu'à -21° C
- Molette robuste en métal sur le côté pour tendre les sangles
- Faible poids
- Bouton-poussoir de déverrouillage

Renforcement des kits EVOLUTION à 4 points d’ancrage pour un classement du fauteuil de 85 à 200 kg, utilisant actuellement 4 x 501906

Eu égard aux exigences croissantes des appels d’offre pour transports en commun et autres, statuant que les systèmes d’arrimage des fauteuils roulants et d’attache de l’occupant à 4 points (WTORS) doivent être classés en fonction du **poids réel du fauteuil roulant transporté**, nous avons décidé de renforcer tous nos kits EVOLUTION d’ancrage en saillie à 4 points pour 85 kg, sauf pour les rails de fixation transversaux. Ainsi, ces kits WTORS pour 85 kg sont compatibles avec nos HEAVY DUTY WTORS pour surpoids, classés à 200 kg + occupant.

Dès lors, les clients qui veulent installer un WTORS 85 kg dans leur véhicule et désirent le renforcer avec nos HEAVY DUTY WTORS, qui sont classés pour des poids de fauteuils roulants respectivement de 200 kg plus occupant, ne doivent pas retourner à l’atelier pour faire installer l’encastrement au sol HEAVY DUTY à 6 points plus solides à l’arrière, et gagnent du temps et épargnent le travail supplémentaire.

La nouvelle armature pour attache au sol (2 x art. no. 503251) pour les sangles ou rétracteurs à l’arrière, remplaçant 2 x art no 501906, est illustrée ici :



	<p>Art. No. 500114</p> <p>MAN TGE 2017- Mercedes Sprinter 907&910 VW Crafter 2006-2016 VW Crafter 2017- HIGH ROOF ONLY</p>		<p>Art. No. 500115</p> <p>MAN TGE 2017- Mercedes Sprinter 907&910 VW Crafter 2006-2016 VW Crafter 2017- HIGH ROOF ONLY</p>

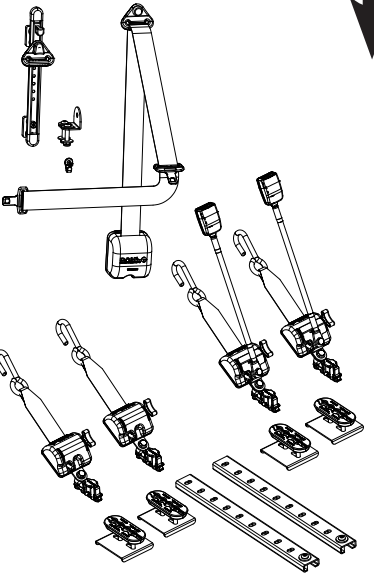

Art. No. 502372

Fiat Doblo
High roof SWB & LWB

Opel Combo
High roof SWB & LWB

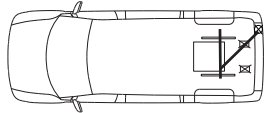
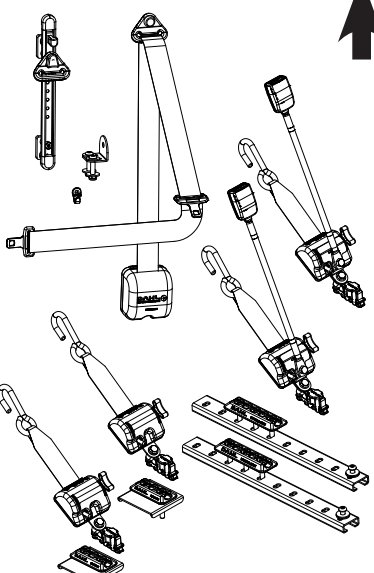
Art. No. 502373

Fiat Doblo
High roof SWB & LWB

Opel Combo
High roof SWB & LWB

Art. No. 503122

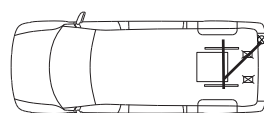
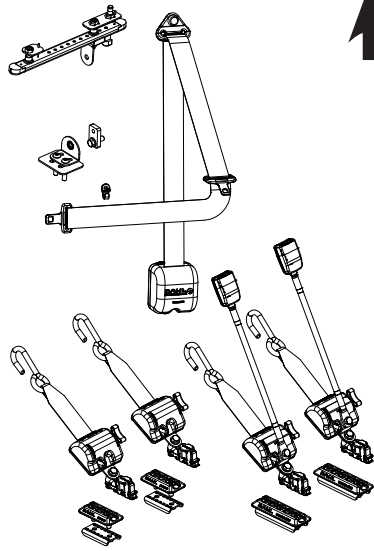
VW T6 Multivan
standard roof height
original floor rails

Art. No. 503130

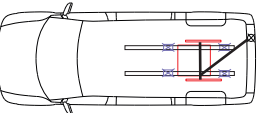
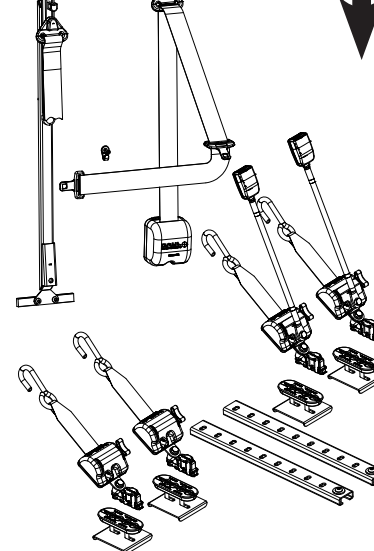
MAN TGE 2017-
VW Crafter 2017-

Art. No. 503131

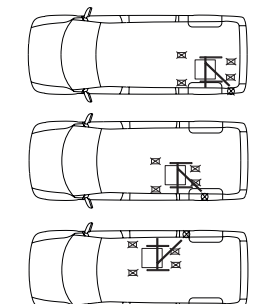
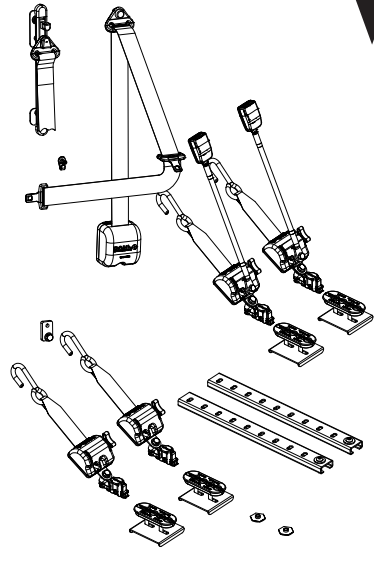
MAN TGE 2017-
VW Crafter 2017-

Art. No. 503132

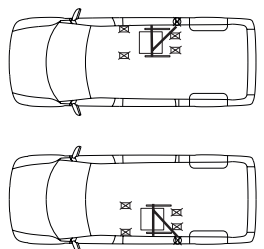
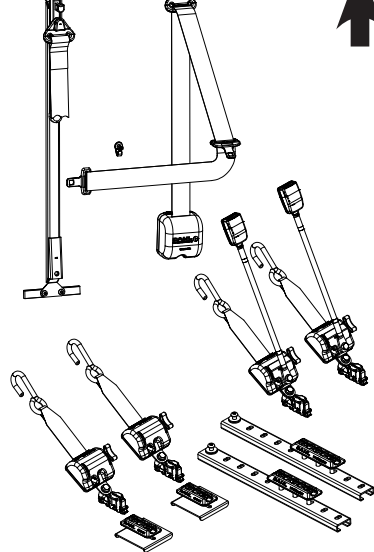
MAN TGE 2017-
VW Crafter 2017-



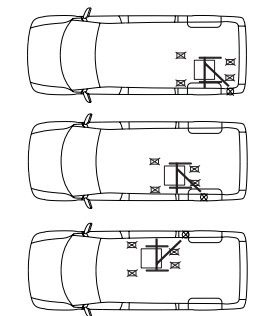

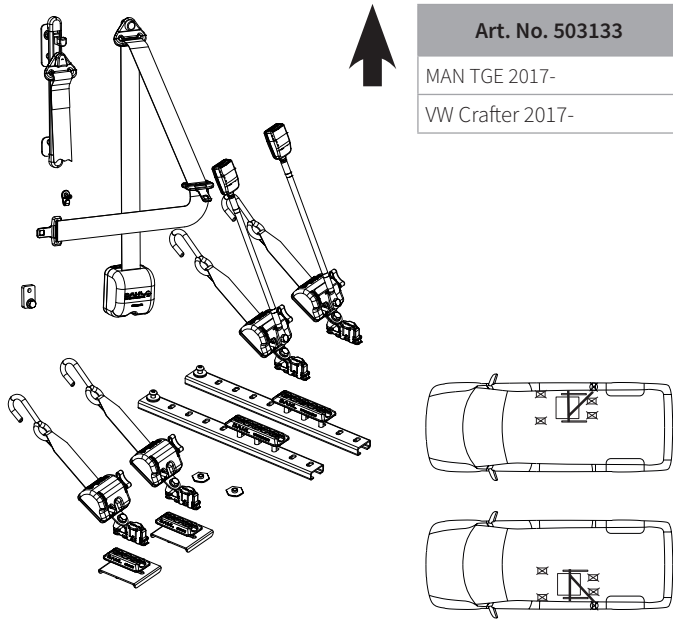
Art. No. 503133
MAN TGE 2017-
VW Crafter 2017-

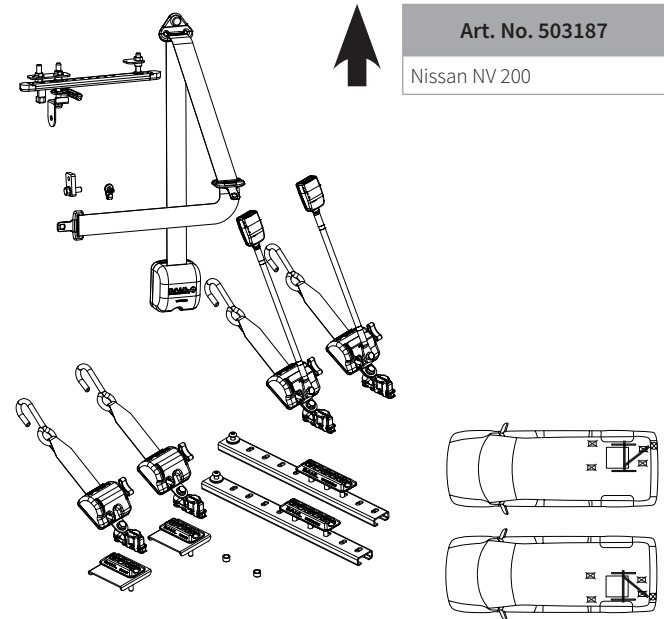

Art. No. 503187
Nissan NV 200

Art. No. 503170
Fiat Talento
Ford Transit V363
Ford Transit Custom V362
Man TGE 2017-
MB Sprinter 906 & 907 & 910
Nissan Primastar
Nissan NV300
Nissan NV400
Opel Vivaro X82 & X83
Opel Movano X62
Renault Master X62
Renault Trafic X82 & X83
VW Crafter 2006-2016
VW Crafter 2017-
VW T5 & T6

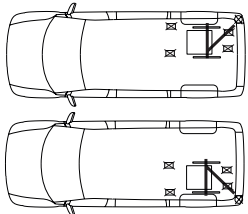

Art. No. 503170
Citroën Jumper Y
Citroën Jumpy X
Fiat Ducato X250
Fiat Scudo X270
Fiat Talento
Ford Transit Custom V362
MB Sprinter 906 & 907 & 910
MB Vito V-Class W639 & W447
Nissan NV300
Nissan NV400
Nissan Primastar
Opel Movano X62
Opel Vivaro X82 & X83
Peugeot Boxer Y
Peugeot Expert X
Renault Master X62
Renault Trafic X82 & X83
Toyota Proace
VW T5 & T6

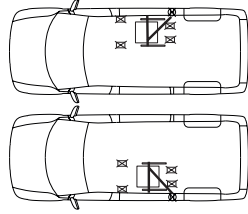

Art. No. 503171
Fiat Talento
Ford Transit V363
Ford Transit Custom V362
Man TGE 2017-
MB Sprinter 906 & 907 & 910
Nissan Primastar
Nissan NV300
Nissan NV400
Opel Vivaro X82 & X83
Opel Movano X62
Renault Master X62
Renault Trafic X82 & X83
VW Crafter 2006-2016
VW Crafter 2017-
VW T5 & T6

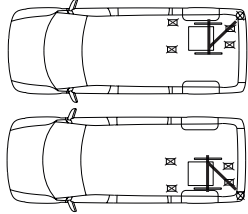

Art. No. 503171
Citroën Jumper Y
Citroën Jumpy X
Fiat Ducato X250
Fiat Scudo X270
Fiat Talento
Ford Transit Custom V362
MB Sprinter 906 & 907 & 910
MB Vito V-Class W639 & W447
Nissan NV300
Nissan NV400
Nissan Primastar
Opel Movano X62
Opel Vivaro X82 & X83
Peugeot Boxer Y
Peugeot Expert X
Renault Master X62
Renault Trafic X82 & X83
Toyota Proace
VW T5 & T6

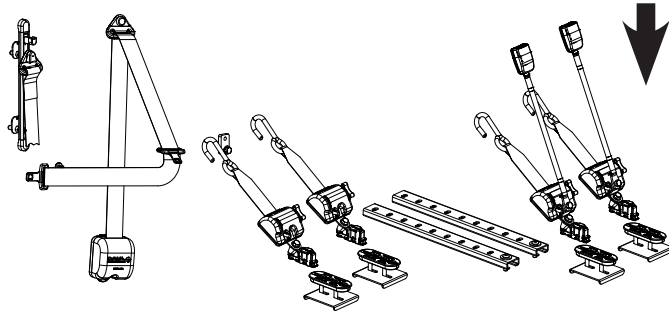
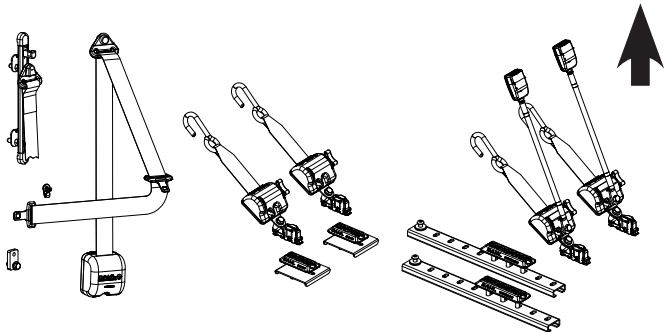
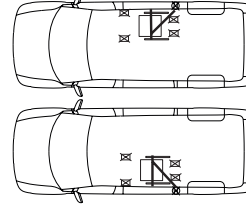

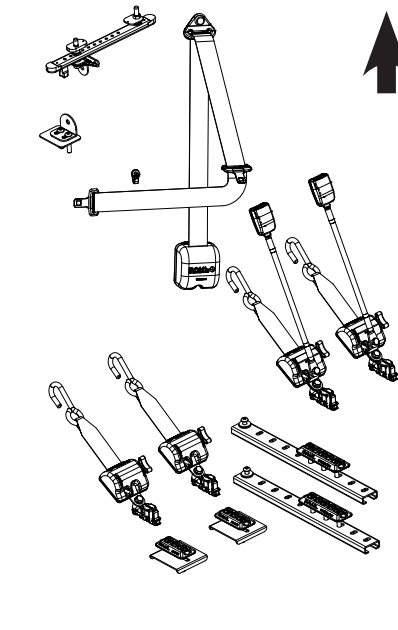

Art. No. 503239

ITEK Drop Floor
Conversion:
VW Caddy Active

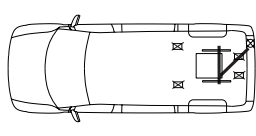
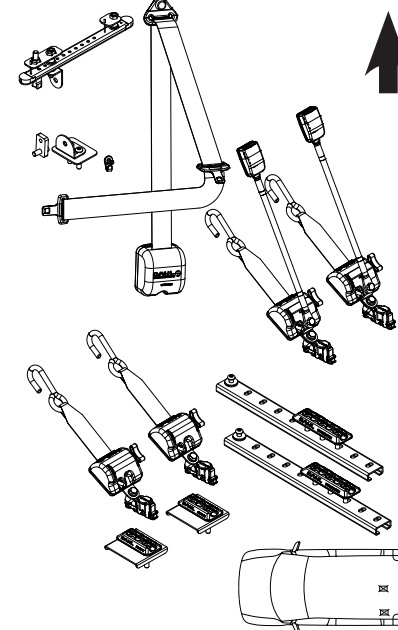
Art. No. 503293

Citroën Jumpy X
Citroën Space Tourer /
Jumpy KO 2016-
Fiat Scudo X270
Ford Transit Custom V362
MB Vito V-Class W639& 447
Opel Zafira Life
Peugeot Expert X
Peugeot Traveller /
Expert KO 2016-
Toyota Proace
Toyota Proace / Verso 2016-
VW T5 + T6

Art. No. 503294

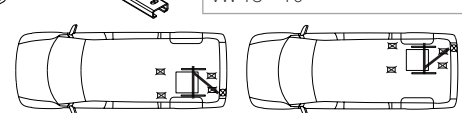
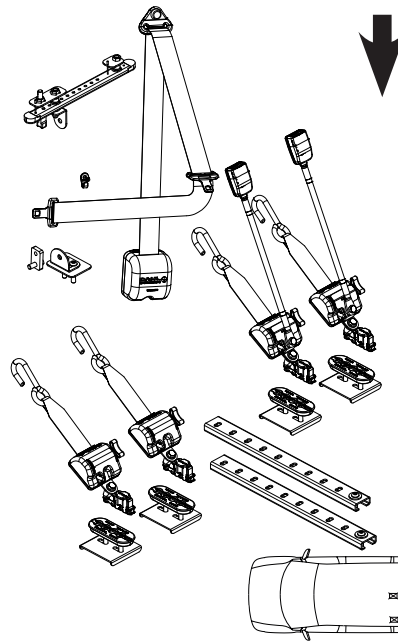
Citroën Jumpy X
Citroën Space Tourer /
Jumpy KO 2016-
Fiat Scudo X270
Ford Transit Custom V362
MB Vito V-Class W639& 447
Opel Zafira Life
Peugeot Expert X
Peugeot Traveller /
Expert KO 2016-
Toyota Proace
Toyota Proace / Verso 2016-
VW T5 + T6

Art. No. 503295

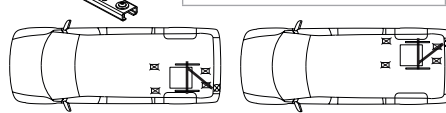
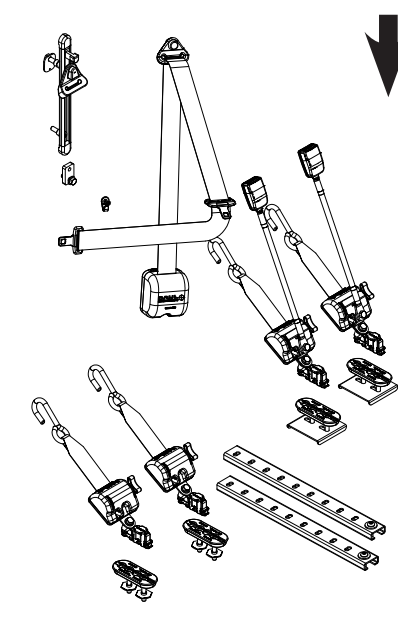
Citroën Space Tourer /
Jumpy KO
Opel Zafira Life
Peugeot Traveller /
Expert KO
Toyota Proace / Verso 2016-

Art. No. 503296

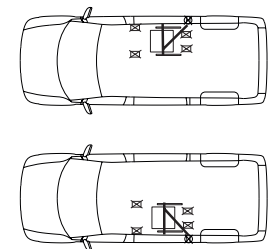
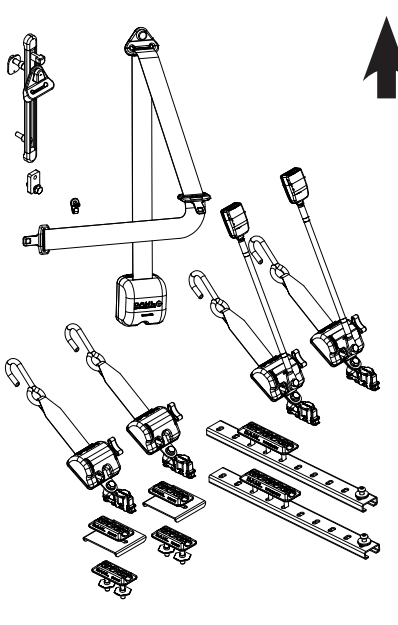
Citroën Space Tourer /
Jumpy KO
Opel Zafira Life
Peugeot Traveller /
Expert KO
Toyota Proace / Verso 2016-



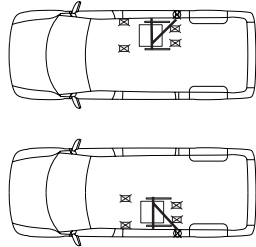
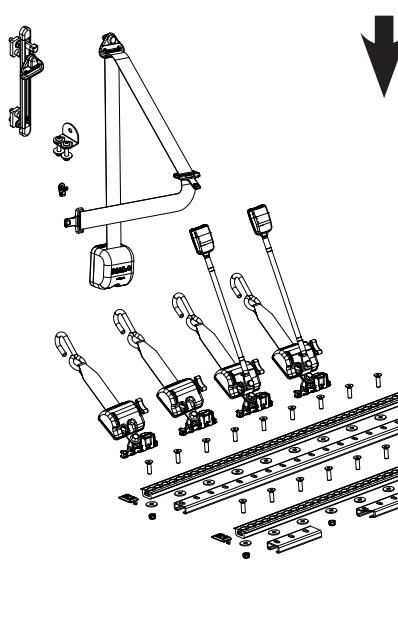

Art. No. 503312

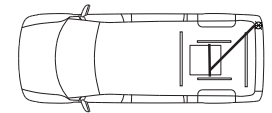
Fiat Doblo
High roof SWB & LWB
Opel Combo
High roof SWB & LWB

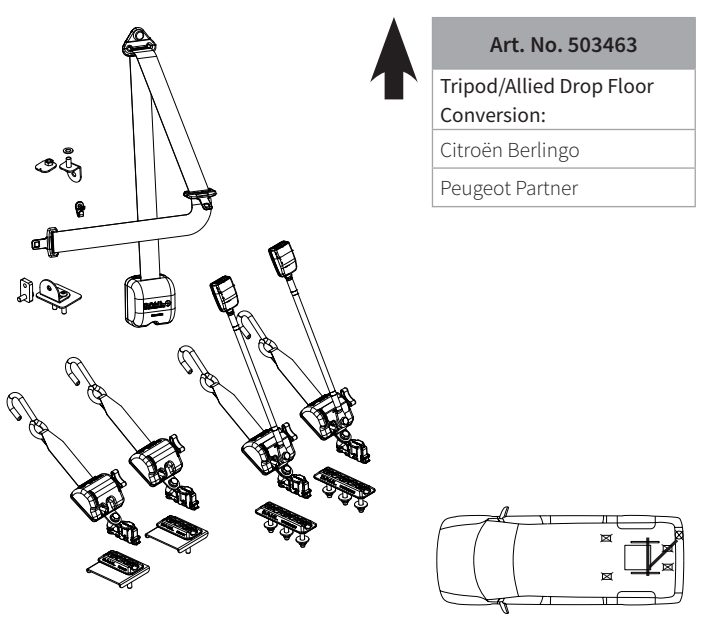
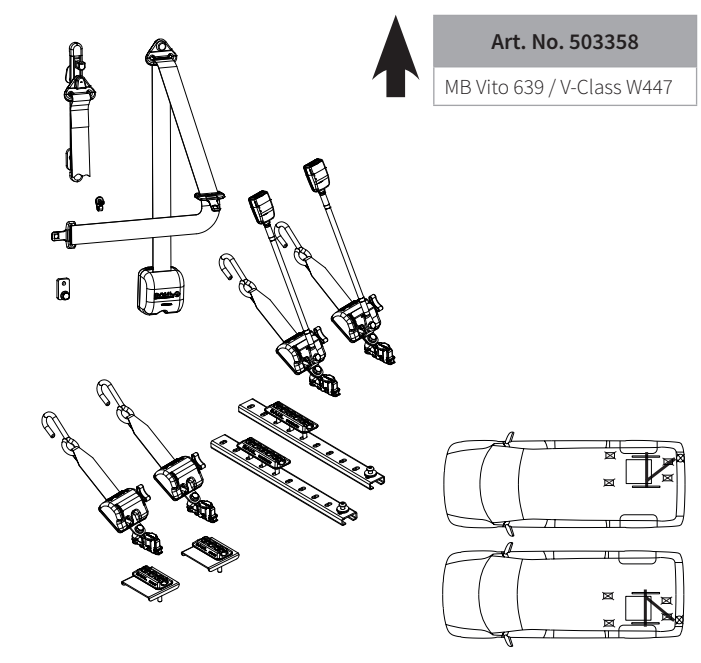
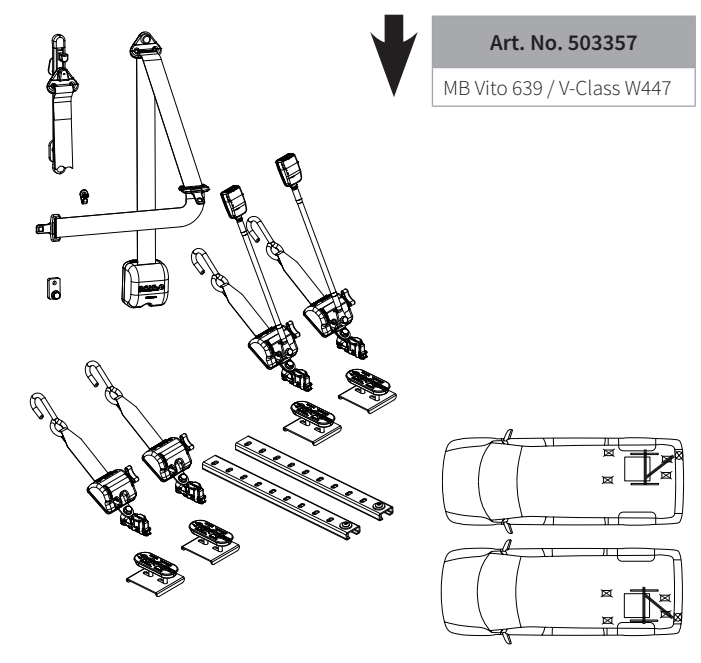
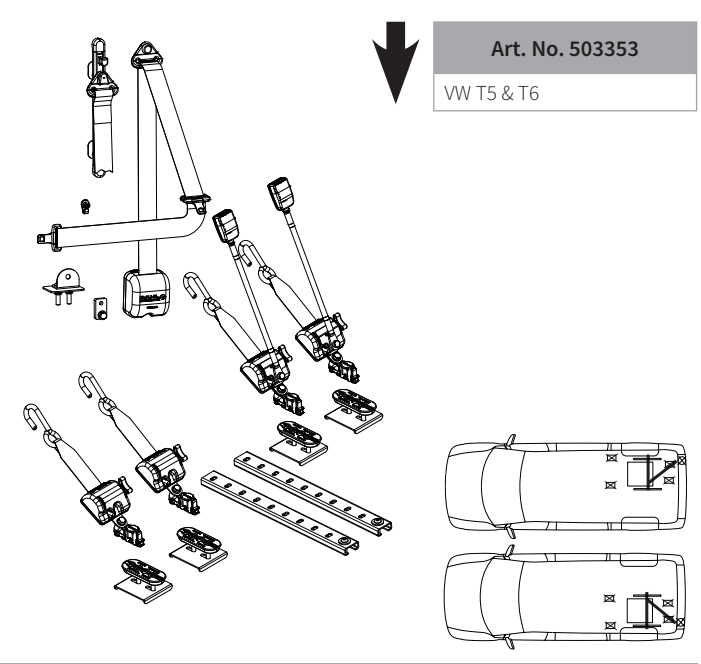
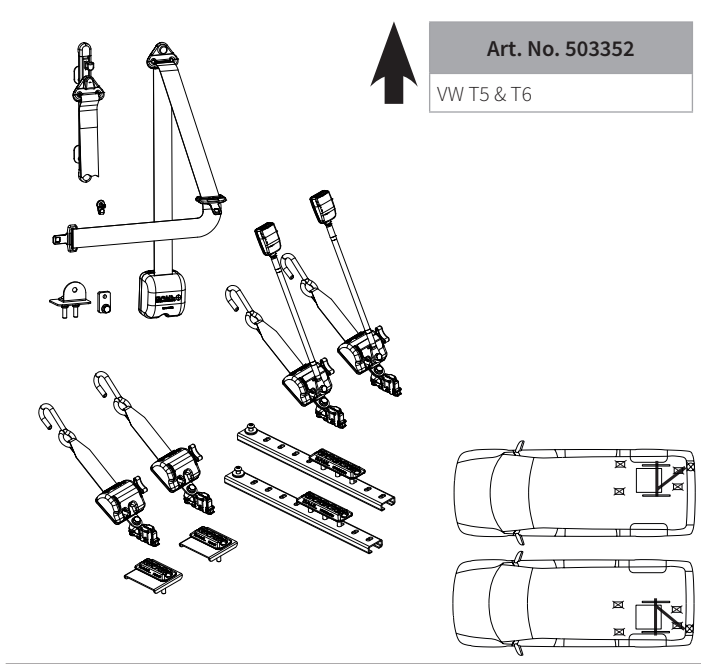

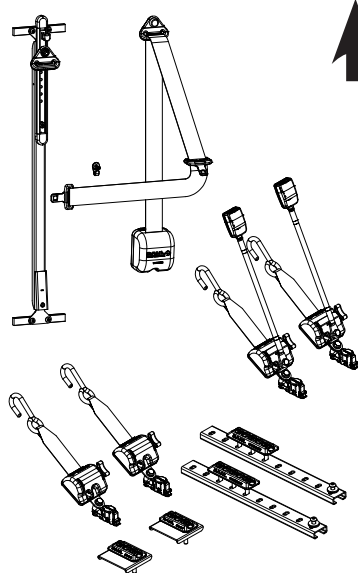



Art. No. 503482
 MB Sprinter 906 & 907 & 910
 VW Crafter (2006-2016)

FMVSS/CMVSS 210

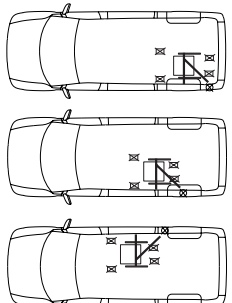
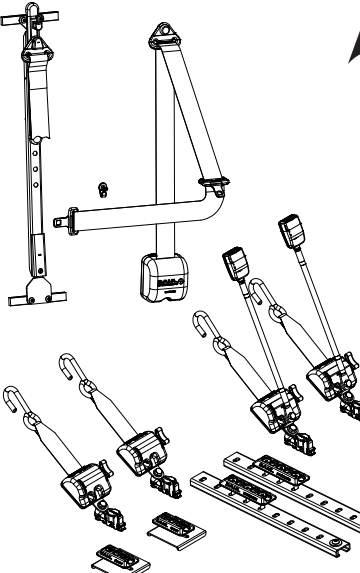
Art. No. 503483
 Fiat Ducato X250
 Peugeot Boxer Y
 Citroën Jumper Y



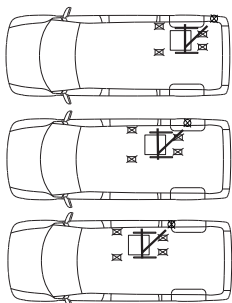
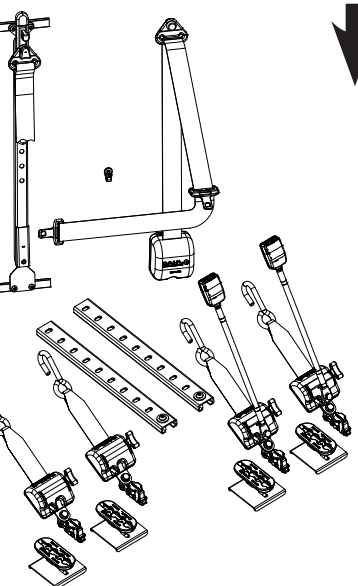

Art. No. 502111
 Fiat Ducato X250
 Peugeot Boxer Y
 Citroën Jumper Y

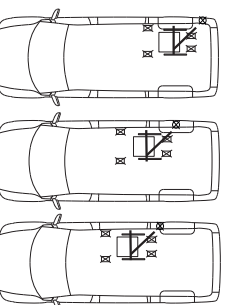
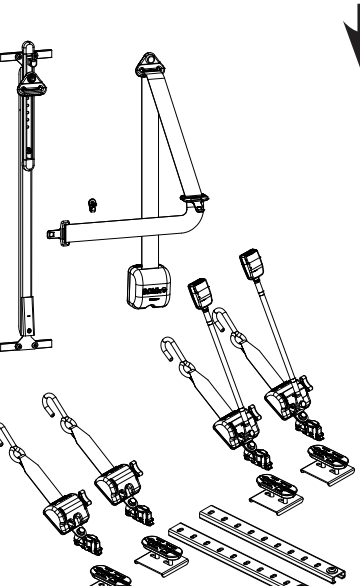

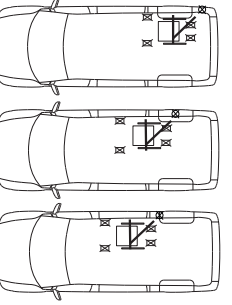
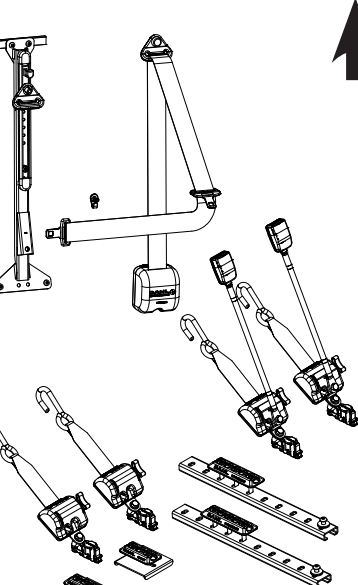

Art. No. 503484
 MB Sprinter 906, 907 & 910
 VW Crafter 2006-2016

FMVSS/CMVSS 210



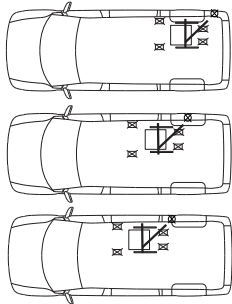
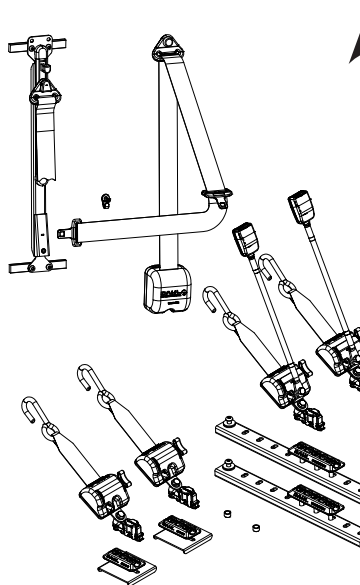

Art. No. 503485
 MB Vito / V-Class W447



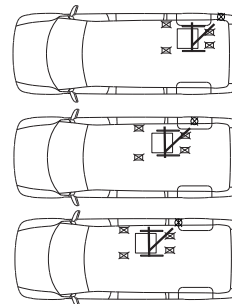

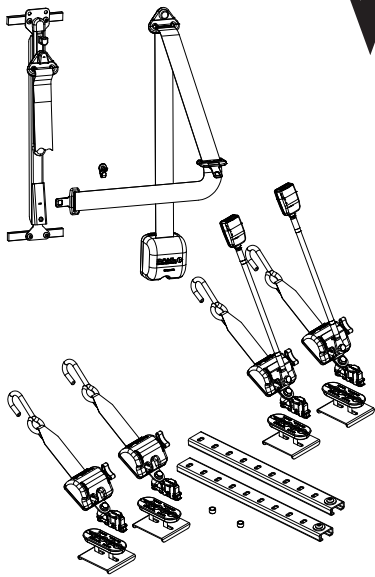
Art. No. 503486
 Nissan NV200
 Ford Transit Custom V362



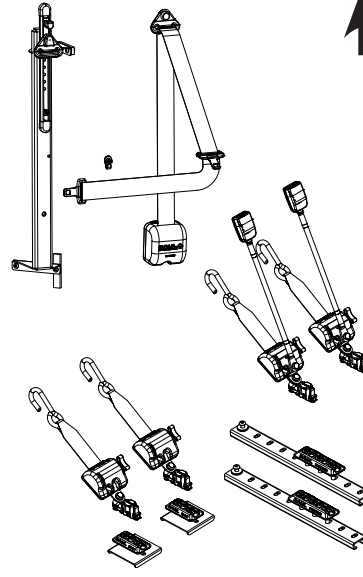
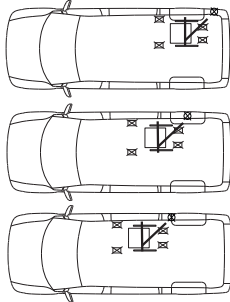

Art. No. 503487
Nissan NV200
Ford Transit Custom V362



Art. No. 503736
Citroën Jumper Y
Fiat Ducato X250
Peugeot Boxer Y

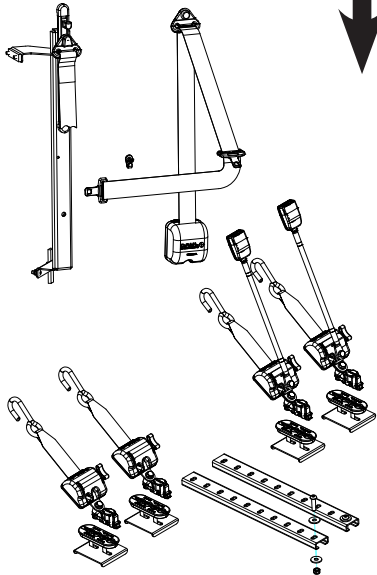
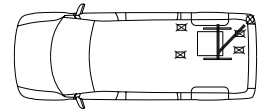

Art. No. 503737
Citroën Jumper Y
Fiat Ducato X250
Peugeot Boxer Y

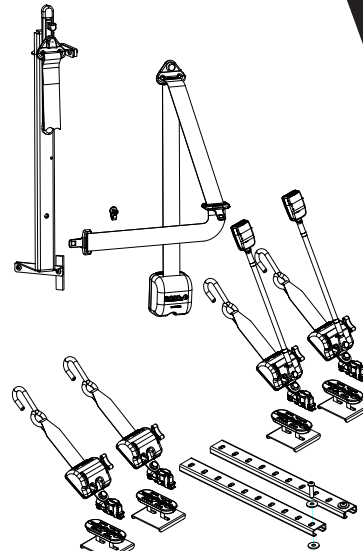
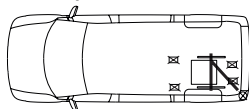

Art. No. 503738
Citroën Jumper Y
Fiat Ducato X250
Peugeot Boxer Y

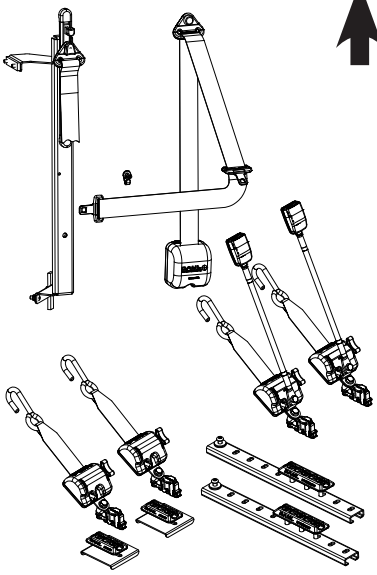
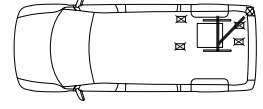

Art. No. 503739
Citroën Jumper Y
Fiat Ducato X250
Peugeot Boxer Y

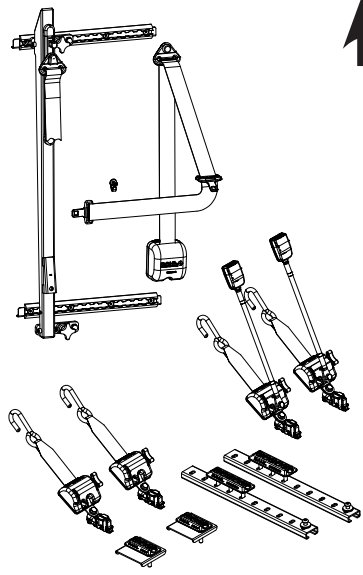
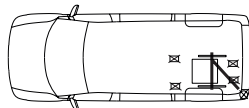

Art. No. 500726
MB Sprinter 906, 907 & 910
VW Crafter 2006-2016
Wheel Bases:
3250, 3665, 4322
HIGH ROOF ONLY

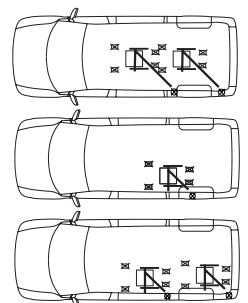

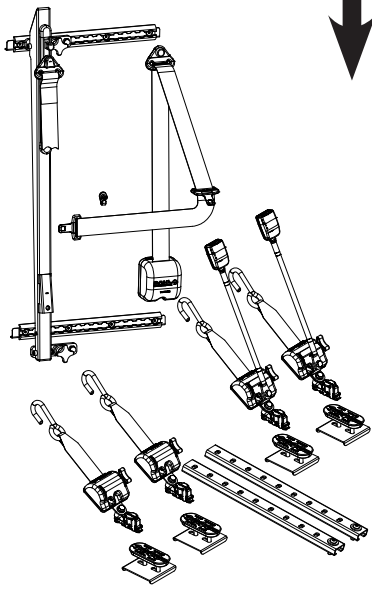

Art. No. 500726
 MB Sprinter 906, 907 & 910
 VW Crafter 2006-2016
 Wheel Bases:
 3250, 3665, 4322
HIGH ROOF ONLY

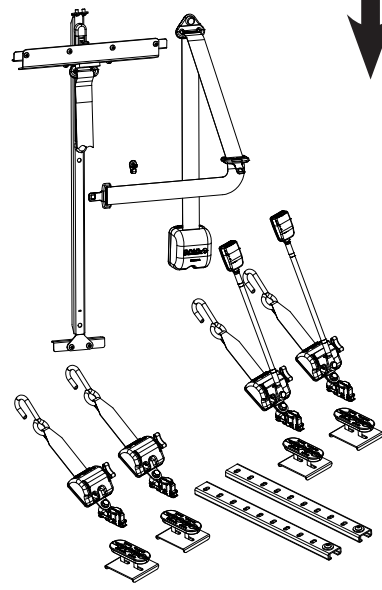
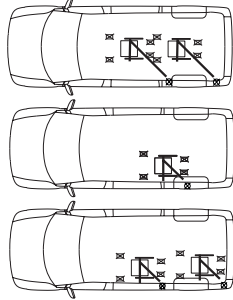

Art. No. 501050
 Ford Transit V363

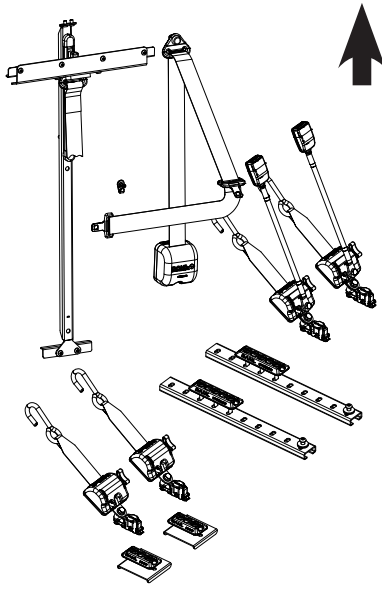
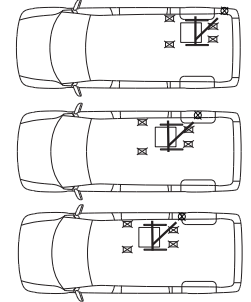

Art. No. 501051
 Ford Transit V363

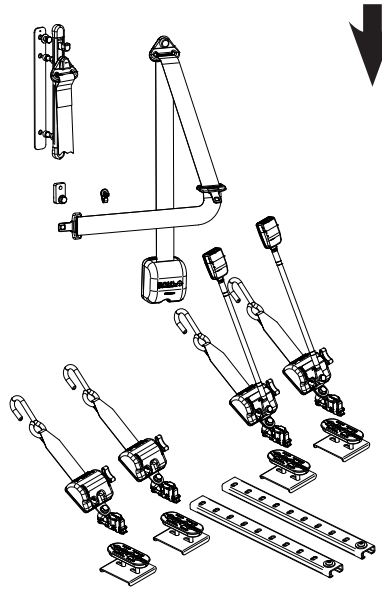
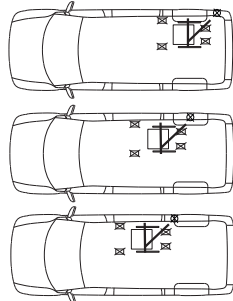

Art. No. 501053
 Ford Transit V363

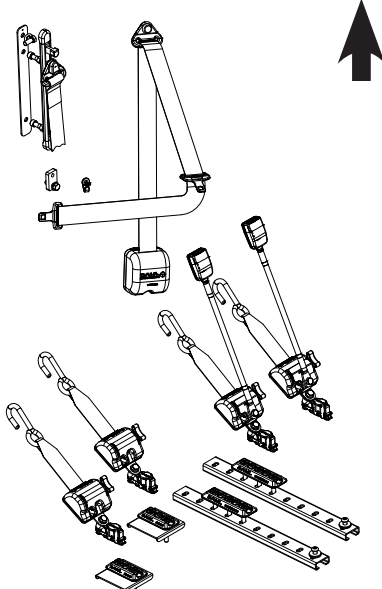
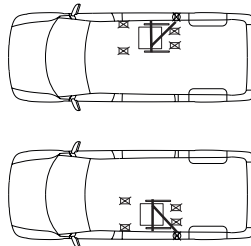

Art. No. 501054
 Ford Transit V363

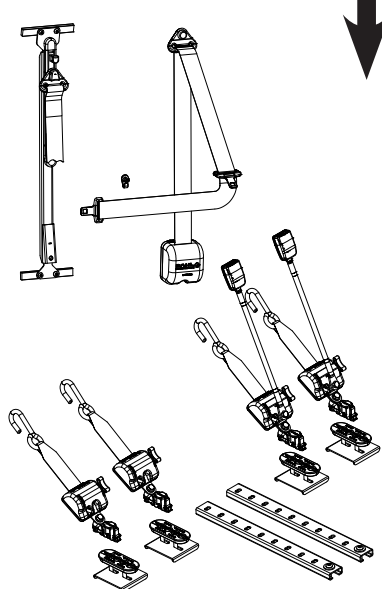
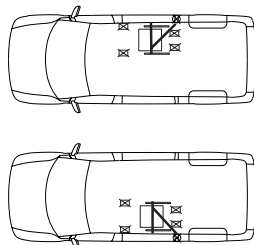

Art. No. 501055
 Citroën Jumpy X
 Fiat Scudo X270
 Peugeot Expert X
 Toyota ProAce

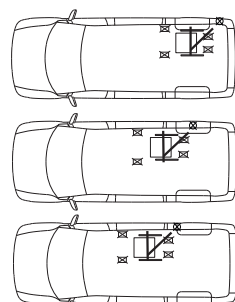

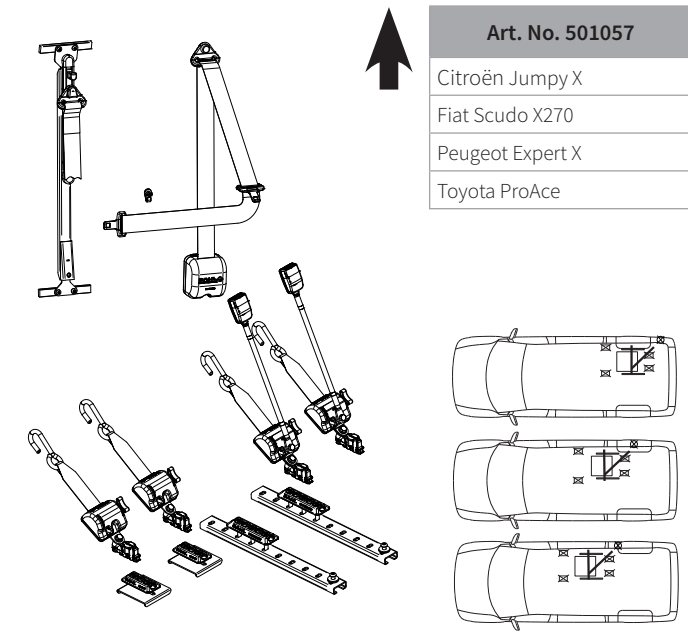

Art. No. 501057

Citroën Jumpy X
Fiat Scudo X270
Peugeot Expert X
Toyota ProAce

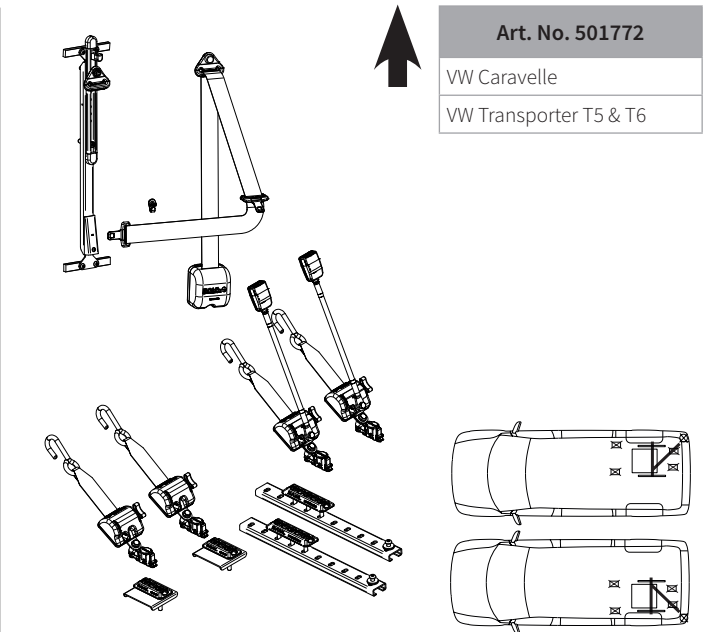

Art. No. 501772

VW Caravelle
VW Transporter T5 & T6

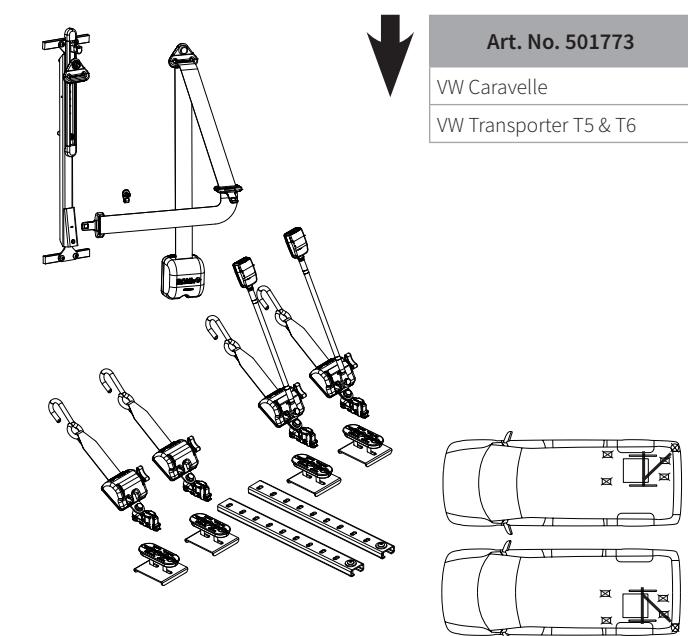

Art. No. 501773

VW Caravelle
VW Transporter T5 & T6

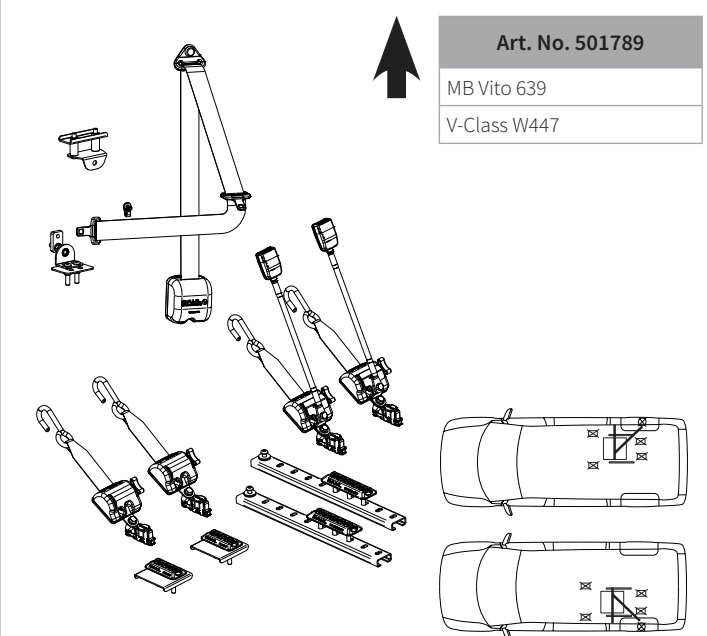

Art. No. 501789

MB Vito 639
V-Class W447

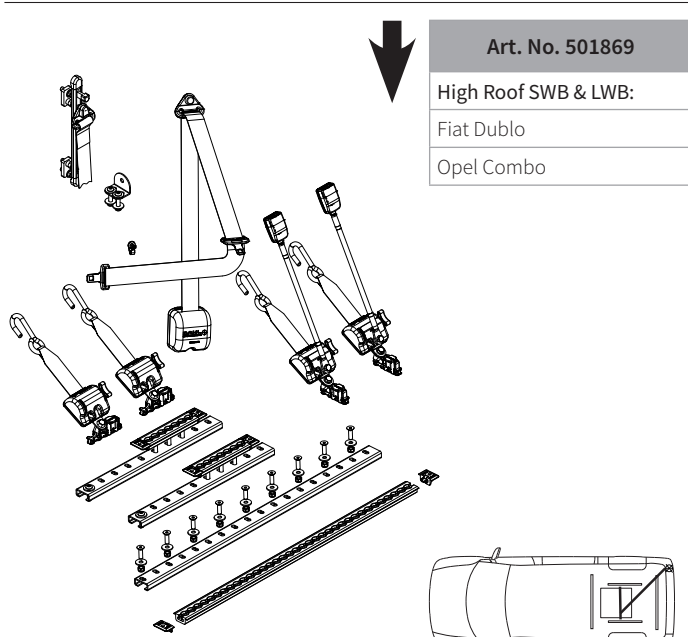

Art. No. 501869

High Roof SWB & LWB:
Fiat Dublo
Opel Combo

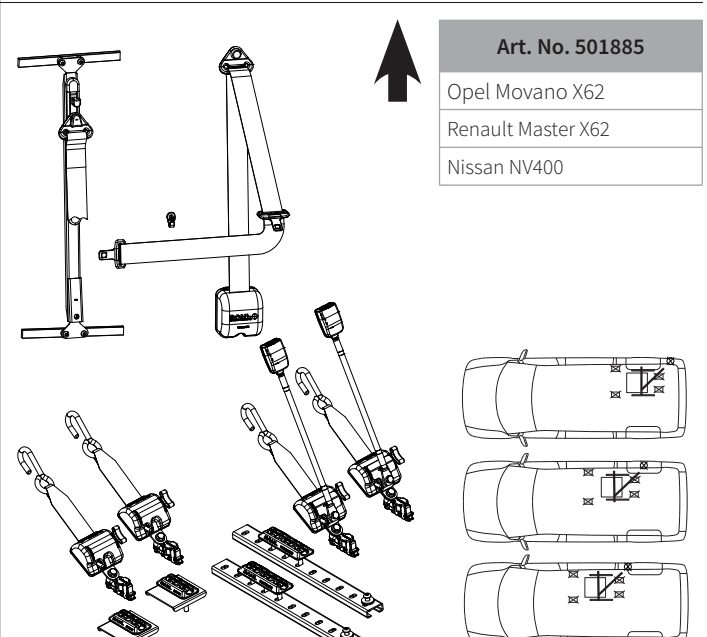

Art. No. 501885

Opel Movano X62
Renault Master X62
Nissan NV400

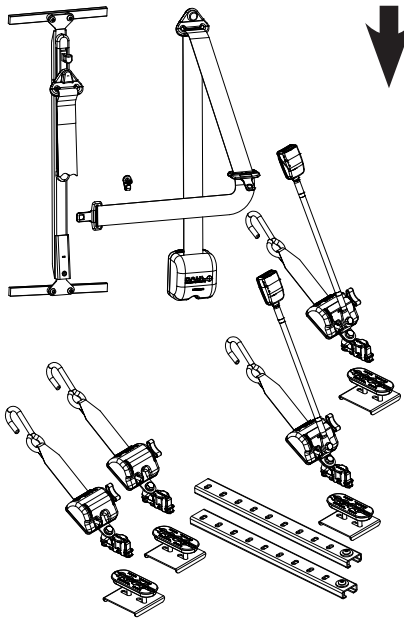

Art. No. 501886
 Opel Movano X62
 Renault Master X62
 Nissan NV400

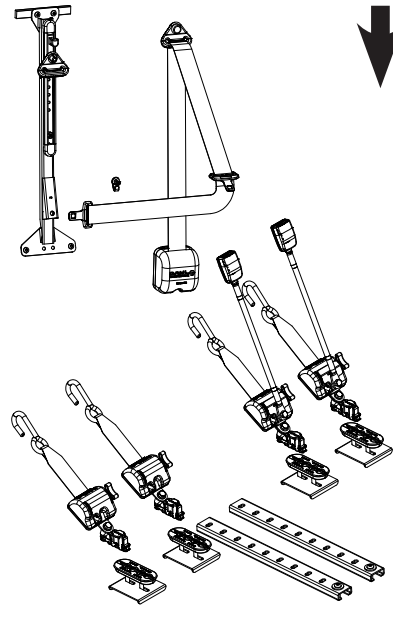
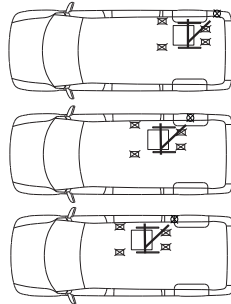

Art. No. 503524
 MB Vito & V-Class W447

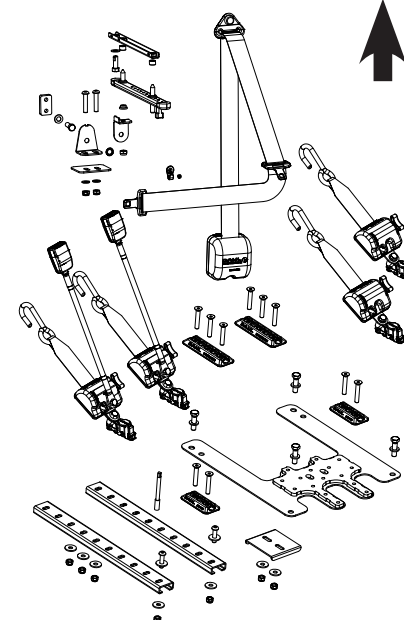
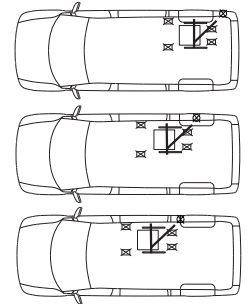

Art. No. 500223 *
 Ford Transit Custom V710*
 VW New Transporter /
 Caravelle 2025-

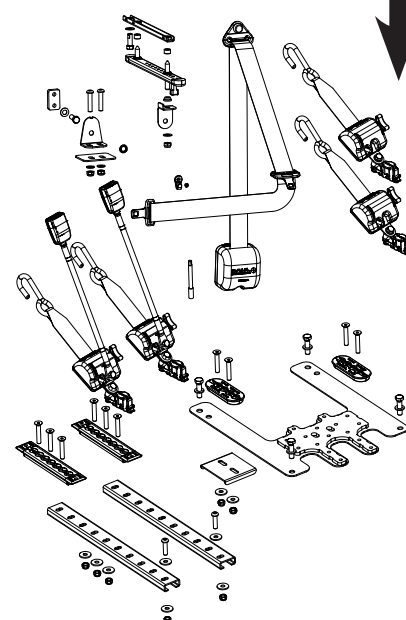
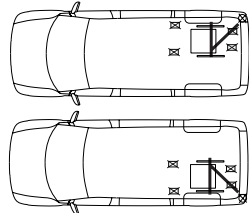

Art. No. 500224 *
 Ford Transit Custom V710
 VW New Transporter /
 Caravelle 2025-

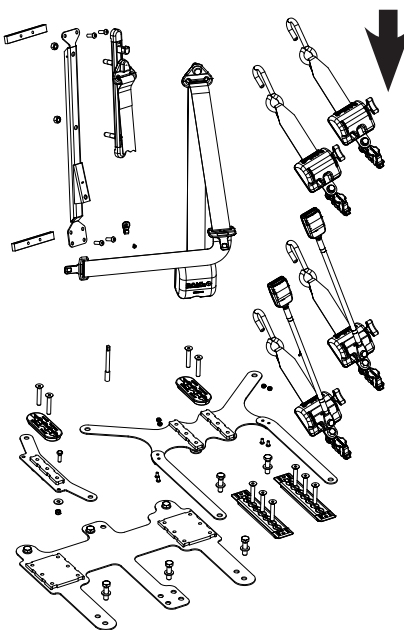
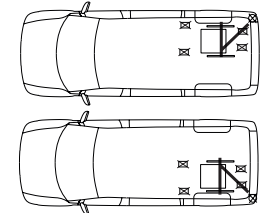

Art. No. 500247 *
 Ford Transit Custom V710
 VW New Transporter /
 Caravelle 2025-

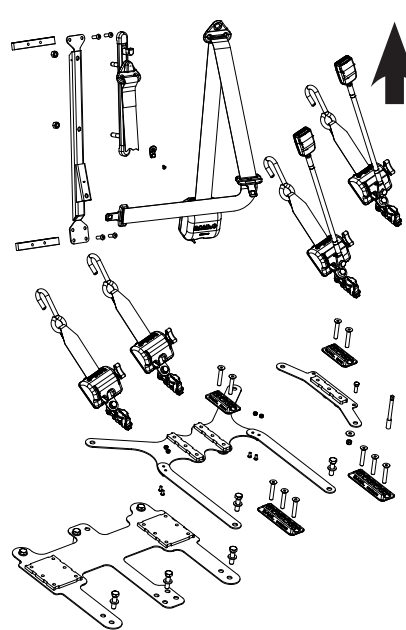
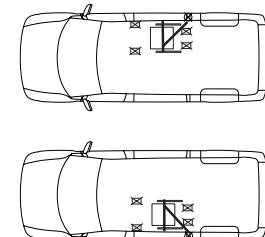

Art. No. 500248 *
 Ford Transit Custom V710
 VW New Transporter /
 Caravelle 2025-

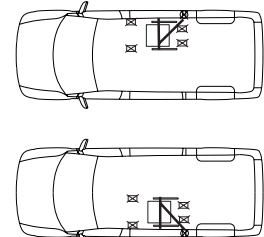

* Voir aussi la liste de compatibilité à la page 38.

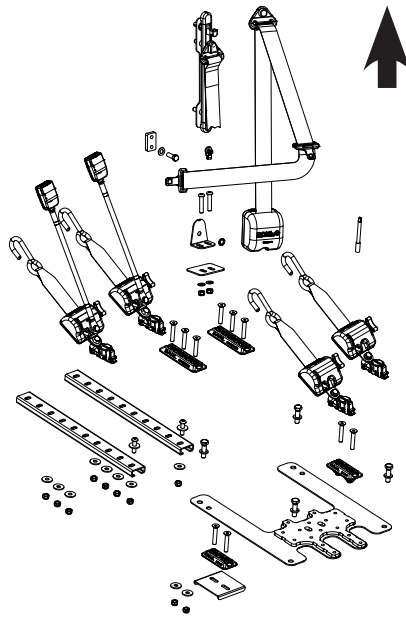

Art. No. 500251 *
 Ford Transit Custom V710
 VW New Transporter /
 Caravelle 2025-

FMVSS/CMVSS
 210

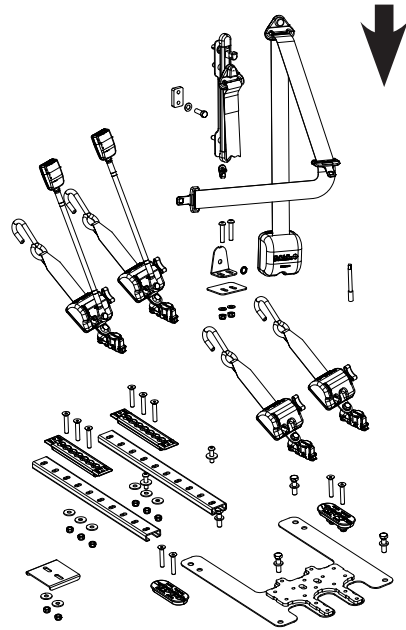
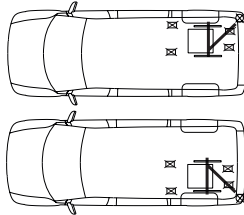

Art. No. 500252 *
 Ford Transit Custom V710
 VW New Transporter /
 Caravelle 2025-

FMVSS/CMVSS
 210

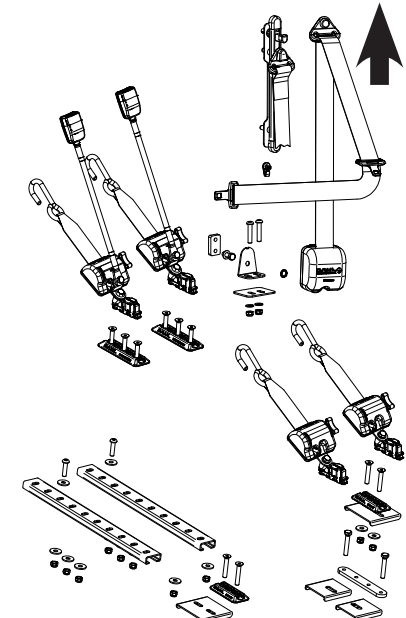
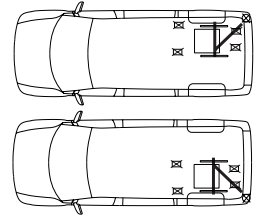

Art. No. 504055 *
 Ford Transit Custom V710
 VW New Transporter /
 Caravelle 2025-

FMVSS/CMVSS
 210

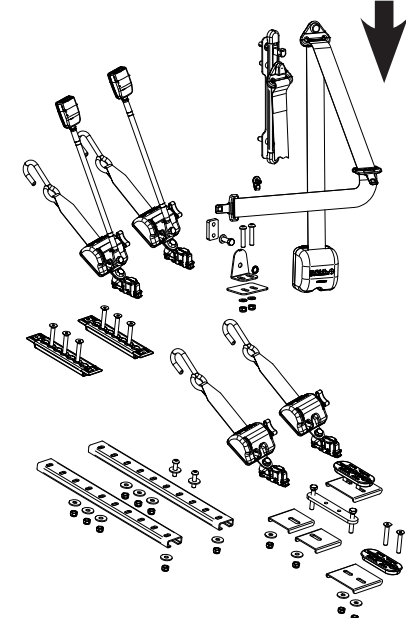
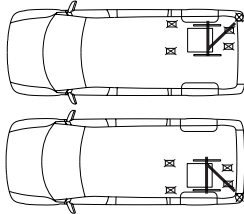

Art. No. 504056 *
 Ford Transit Custom V710
 VW New Transporter /
 Caravelle 2025-

FMVSS/CMVSS
 210

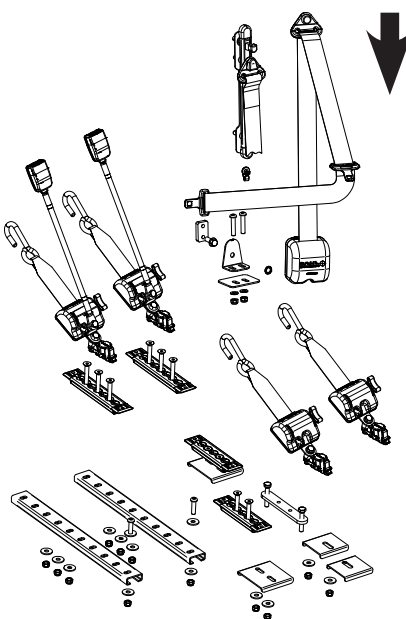
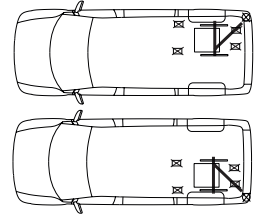

Art. No. 504057 *
 Ford Transit Custom V710
 VW New Transporter /
 Caravelle 2025-

FMVSS/CMVSS
 210

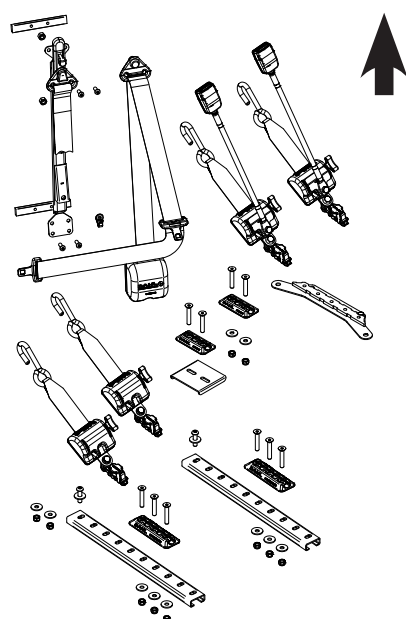
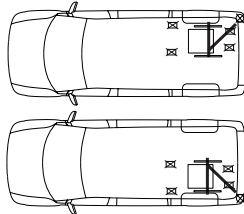

Art. No. 504058 *
 Ford Transit Custom V710
 VW New Transporter /
 Caravelle 2025-

FMVSS/CMVSS
 210

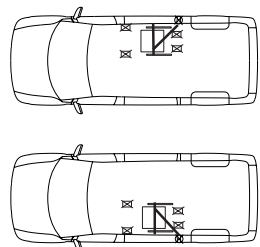

* Voir aussi la liste de compatibilité à la page 38.

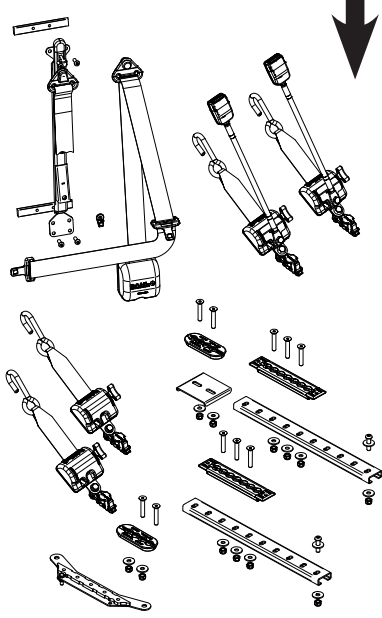

Art. No. 504059 *

Ford Transit Custom V710
VW New Transporter /
Caravelle 2025-

FMVSS/CMVSS 210

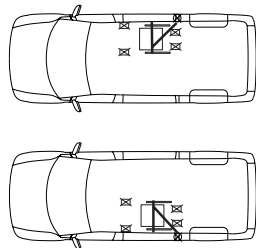
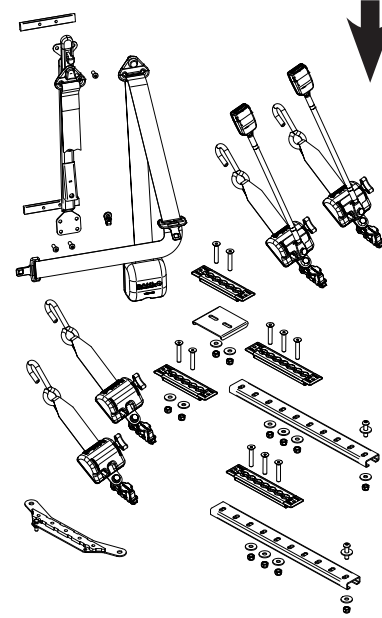
Art. No. 504060 *

Ford Transit Custom V710
VW New Transporter /
Caravelle 2025-

FMVSS/CMVSS 210

Art. No. 504115 *

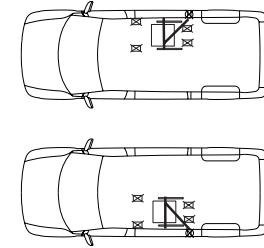
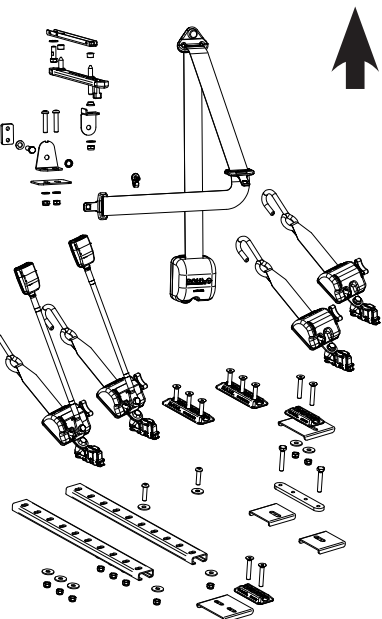
Ford Transit Custom V710
VW New Transporter /
Caravelle 2025-

FMVSS/CMVSS 210

Art. No. 504137 *

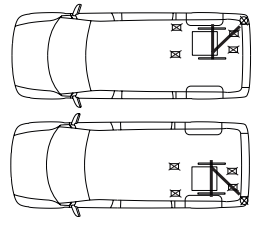
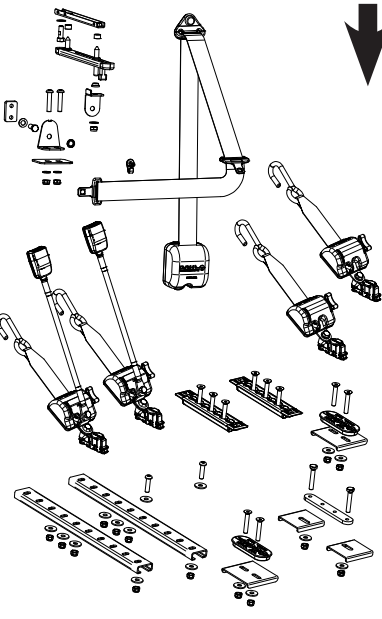
Ford Transit Custom V710
VW New Transporter /
Caravelle 2025-

FMVSS/CMVSS 210

Art. No. 504165

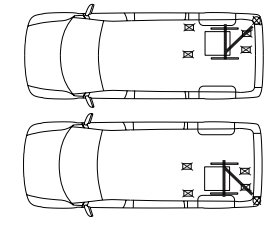
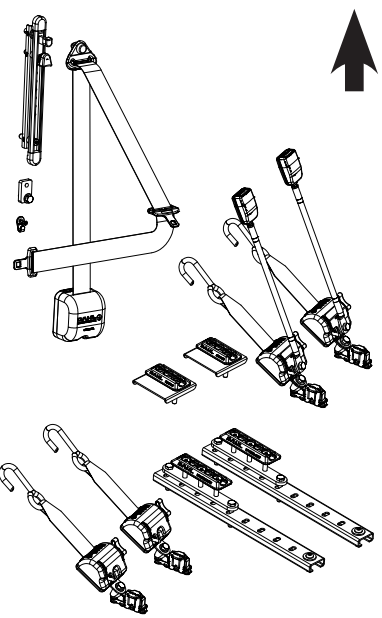
Renault Master XDD
Nissan Interstar 2024-

FMVSS/CMVSS 210

Art. No. 504173

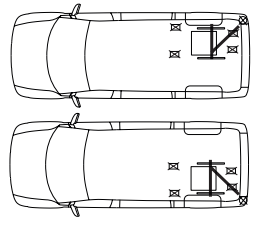
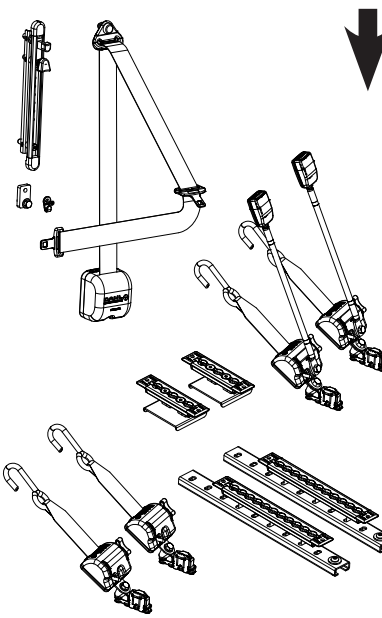
Renault Master XDD
Nissan Interstar 2024-

FMVSS/CMVSS 210

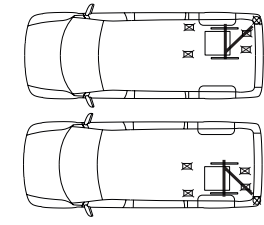

* Voir aussi la liste de compatibilité à la page 38.

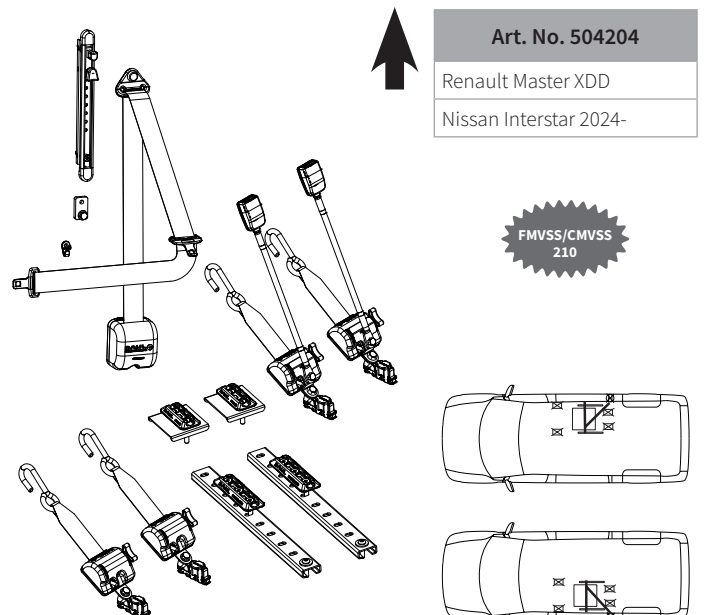
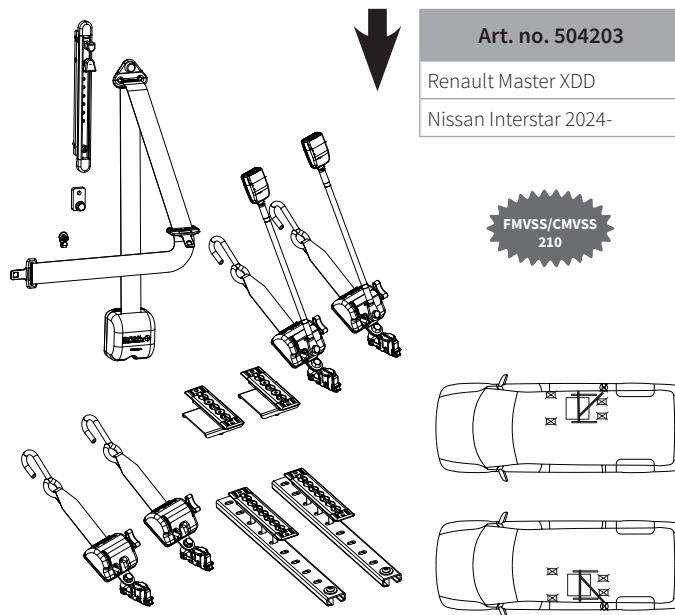
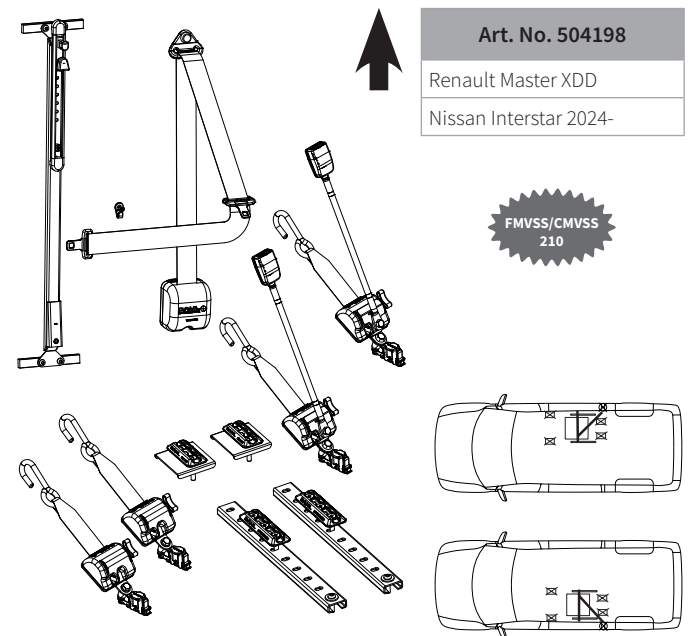
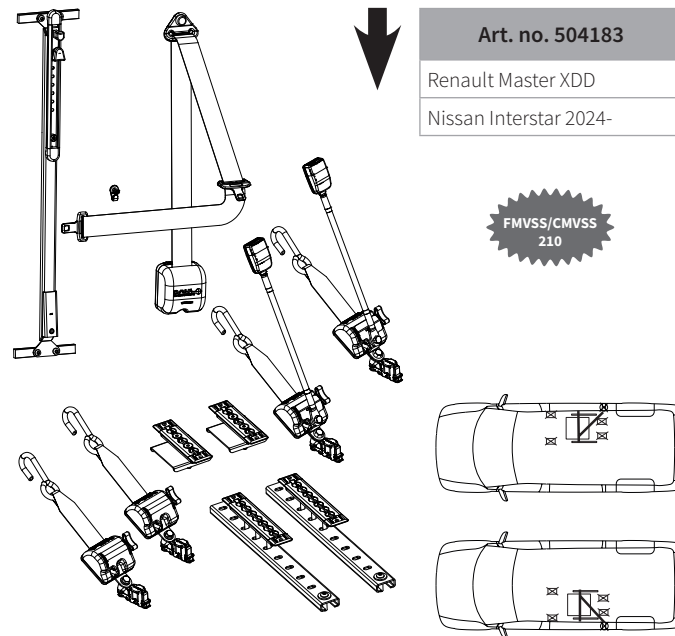
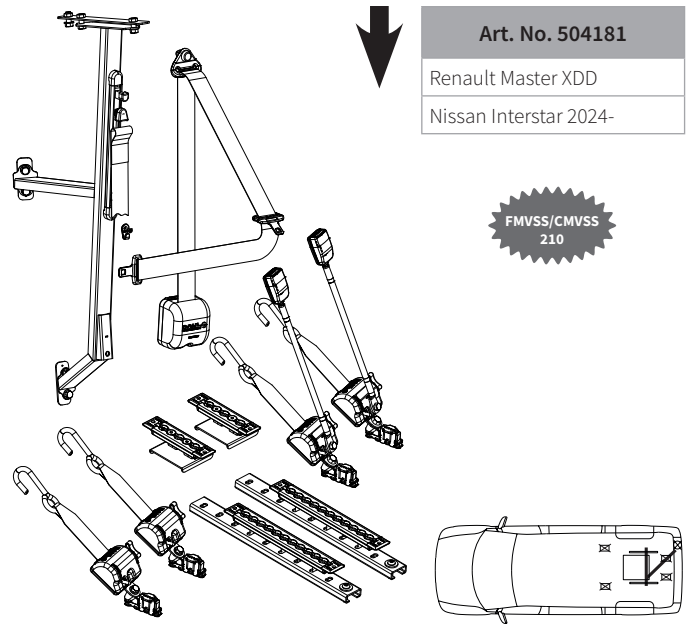
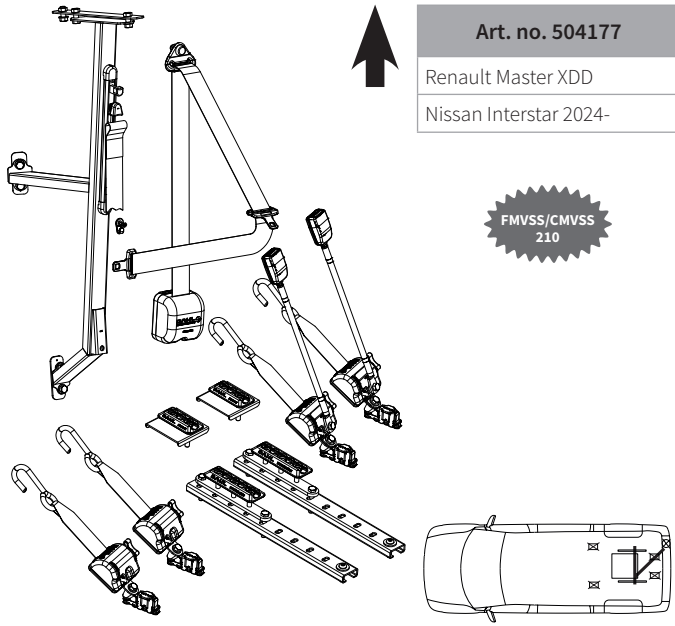

«Ligne HEAVY DUTY»

– Adaptée pour les fauteuils roulants jusqu'à 200 kg plus utilisateur

Le poids des fauteuils roulants électriques étant, pour la majorité, bien supérieur aux 85 kg préconisés par la réglementation actuelle sur les systèmes de retenue F.R., Dahl Engineering est le premier fabricant au monde à avoir développé un système de retenue renforcé et homologué par le TÜV, et ce, présenté sous forme de kits d'installation dédiés à des véhicules spécifiques.

Ces kits brevetés surpassent significativement les exigences techniques du règlement 2018/858 de l'UE car peuvent être utilisés pour les fauteuils roulants pesant 200 kg, plus l'utilisateur.



Système de retenue pour fauteuils roulants jusqu'à 200 kg + utilisateur

- Système d'arrimage avec kit d'installation spécifique au véhicule
- Kits testés dans des modèles de véhicules et des zones d'installation spécifiques
- Test de résistance dynamique à 48 km/h du kit complet (Sangle à enrouleur, ceinture de sécurité, ancrage sur plancher, ajusteurs de ceinture en hauteur)
- Développement de nouveaux modèles d'ancrage sur plancher
- Rapports TÜV et documentation pour tous les kits d'installation sur véhicules spécifiques disponibles
- Breveté

Art. No. 503135
Fiat Talento X82
Ford Transit Custom V362
Man TGE 2017 - -
MB Sprinter 906, 907 & 910
Nissan NV300 & NV400
Opel Movano X62
Opel Vivaro X82 & X83
Renault Master X62
Renault Traffic X82 & X83
VW Crafter 2017-
VW T5 & T6

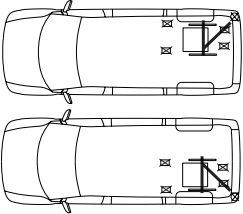

Art. No. 503135
Citroën Jumper Y
Fiat Ducato X250
Fiat Talento X82
Ford Transit Custom V362
MB Sprinter 906, 907, 910
MB Vito V-Class W639 & W447
Nissan NV300 & NV400
Opel Movano X62
Opel Vivaro X82 & X83
Peugeot Boxer Y
Renault Master X62
Renault Traffic X82 & X83
VW T5 & T6

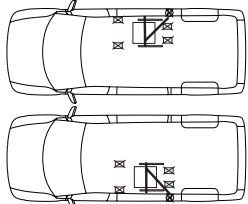
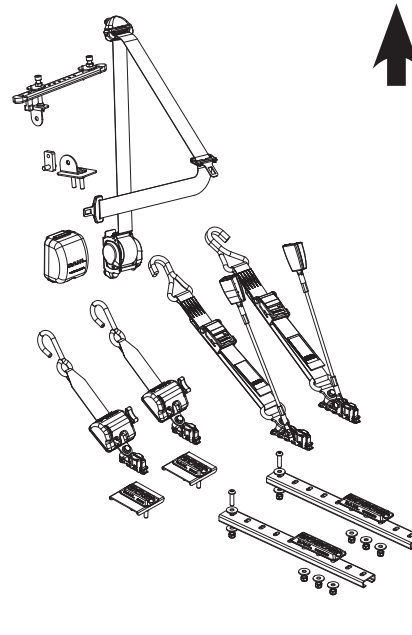
Art. No. 503299
Citroën Jumpy / Space Tourer K0
MB Vito/V-Class W639 & 447
Opel Zafira Life
Peugeot Expert / Traveller K0
Toyota Proace / Verso 2016-
VW T5& T6

Art. No. 503300
Citroën Jumpy / Space Tourer K0
MB Vito/V-Class W639 & 447
Opel Zafira Life
Peugeot Expert / Traveller K0
Toyota Proace / Verso 2016-
VW T5& T6

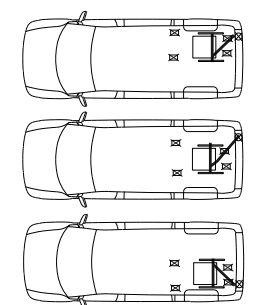
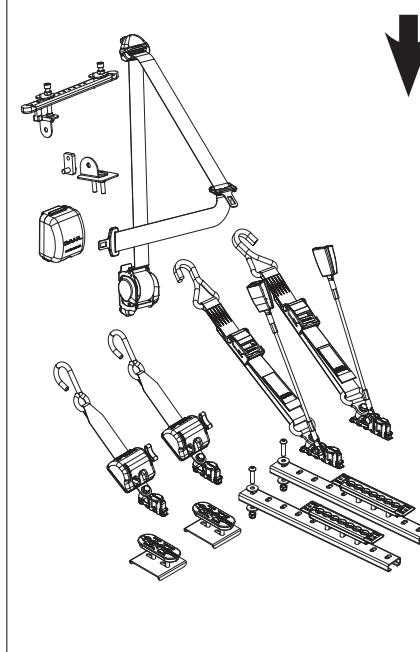

Art. No. 503464
Tripod/Allied Drop Floor Conversion:
Citroën Berlingo
Peugeot Partner

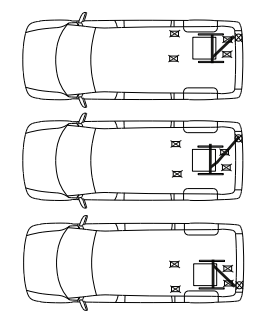

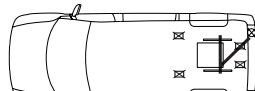
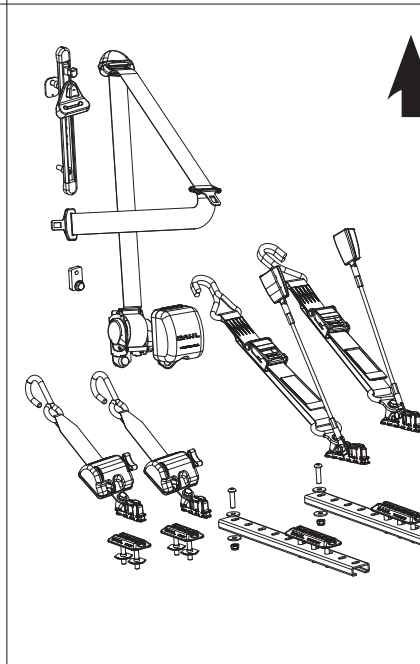

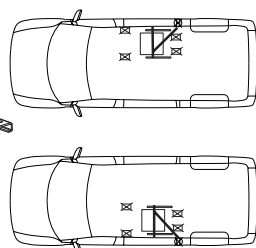
Art. No. 503472
Citroën Jumpy / Space Tourer K0
Opel Zafira Life
Peugeot Expert / Traveller K0
Toyota Proace / Verso 2016-

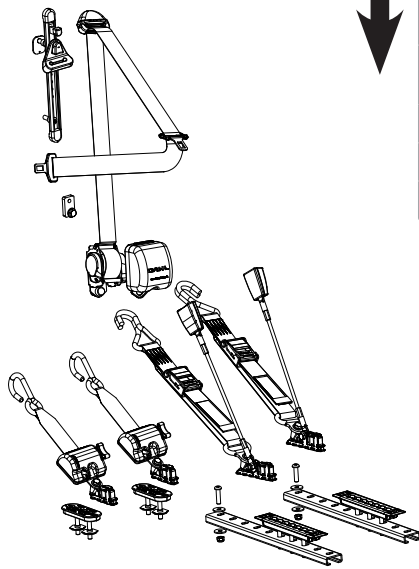

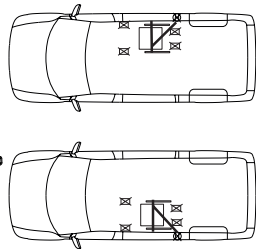

Art. No. 503474
 Citroën Jumpy /
 Space Tourer K0
 Opel Zafira Life
 Peugeot Expert / Traveller K0
 Toyota Proace / Verso 2016-



Art. No. 503488
 Fiat Talento X82
 Ford Transit Custom V362
 Man TGE 2017 - -
 MB Sprinter 906, 907 & 910
 Nissan NV300 & NV400
 Opel Movano X62
 Opel Vivaro X82 & X83
 Renault Master X62
 Renault Traffic X82 & X83
 VW Crafter 2017-
 VW T5 & T6

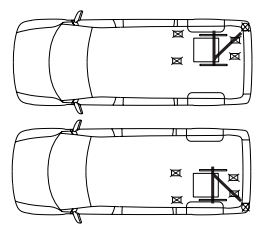

Art. No. 503488
 Citroën Jumper Y
 Fiat Ducato X250
 Fiat Talento X82
 Ford Transit Custom V362
 MB Sprinter 906, 907, 910
 MB Vito V-Class W639 & W447
 Nissan NV300 & NV400
 Opel Movano X62
 Opel Vivaro X82 & X83
 Peugeot Boxer Y
 Renault Master X62
 Renault Traffic X82 & X83
 VW T5 & T6

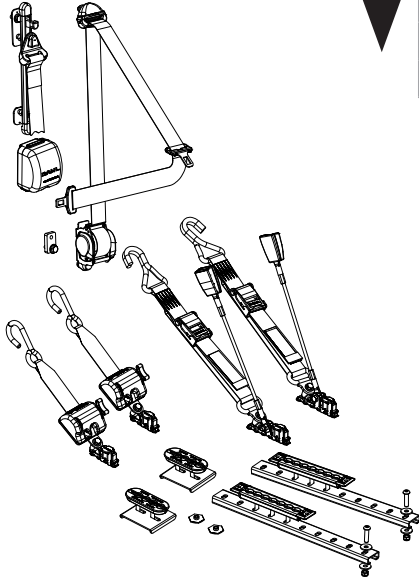
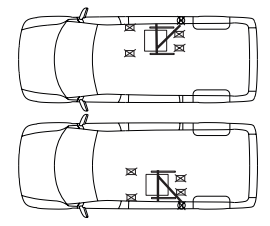

Art. No. 503493
 Man TGE 2017 -
 VW Crafter 2017-

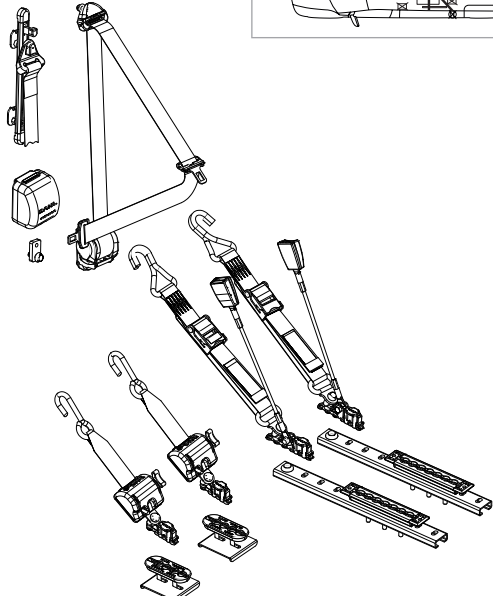
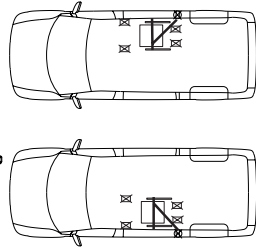

Art. No. 503495
 Man TGE 2017 -
 VW Crafter 2017-

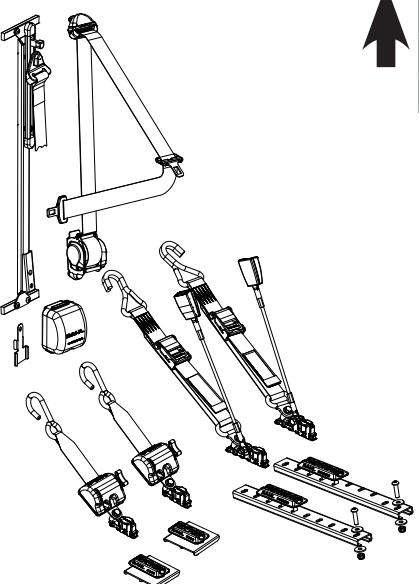
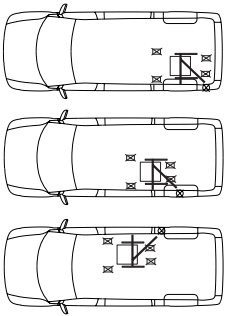

Art. No. 503494
 Man TGE 2017 -
 VW Crafter 2017-

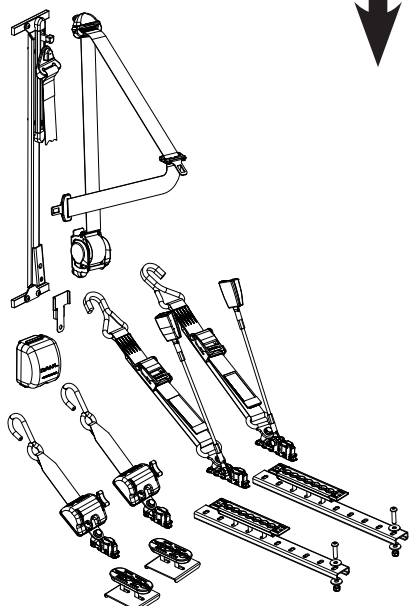
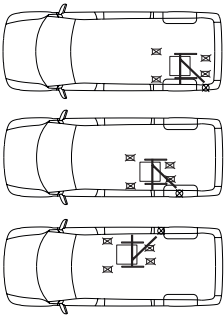

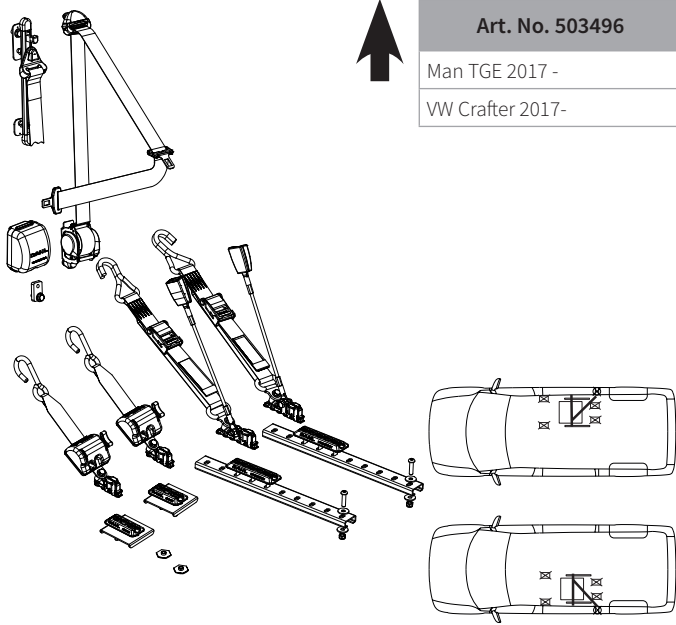

Art. No. 503496
Man TGE 2017 -
VW Crafter 2017-

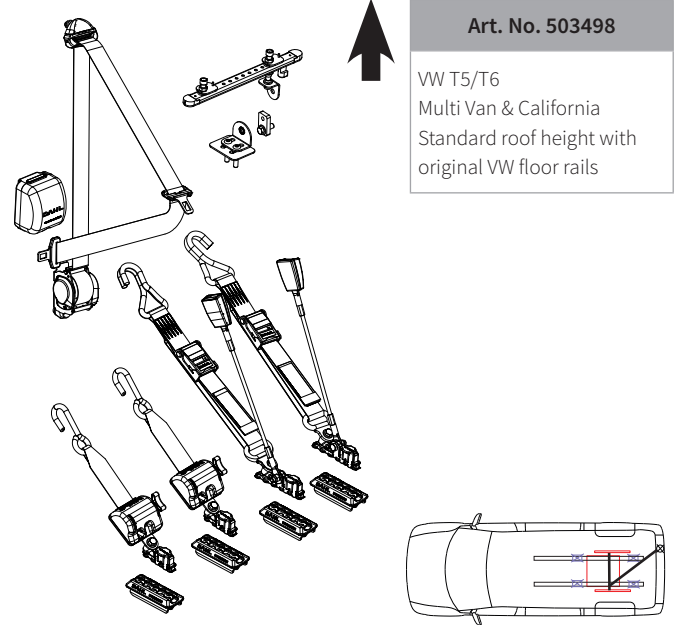

Art. No. 503498
VW T5/T6
Multi Van & California
Standard roof height with
original VW floor rails

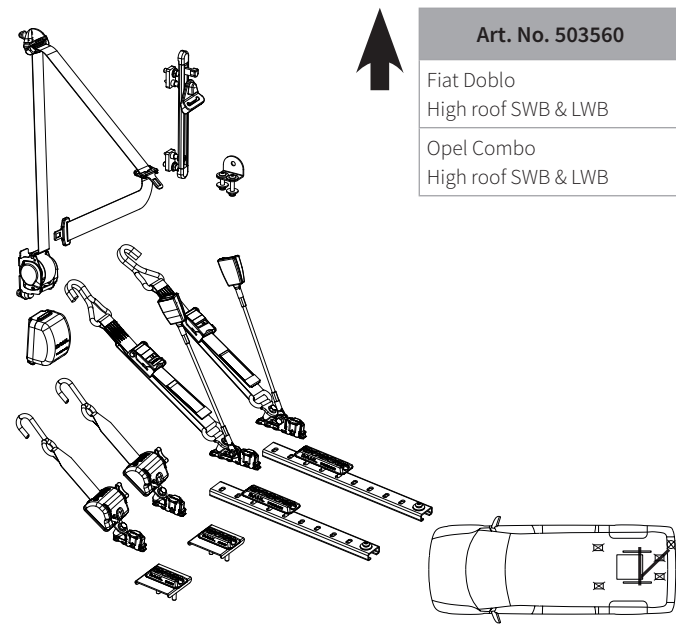

Art. No. 503560
Fiat Doblo
High roof SWB & LWB
Opel Combo
High roof SWB & LWB

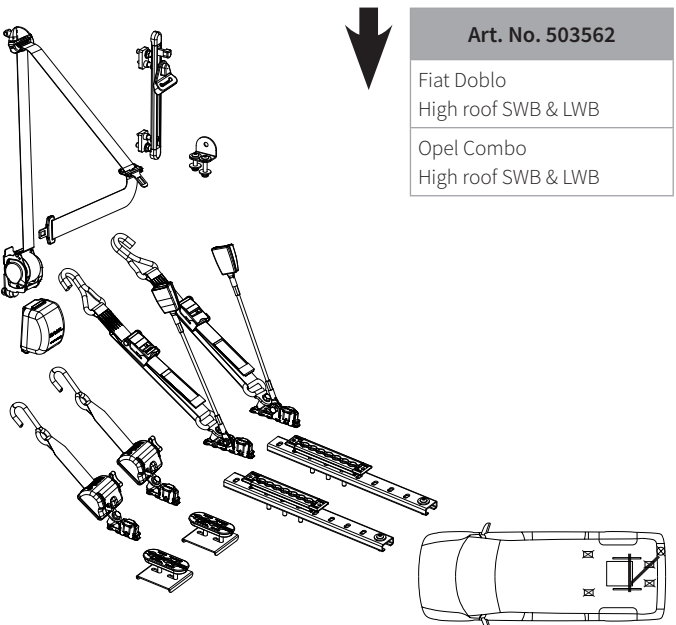

Art. No. 503562
Fiat Doblo
High roof SWB & LWB
Opel Combo
High roof SWB & LWB

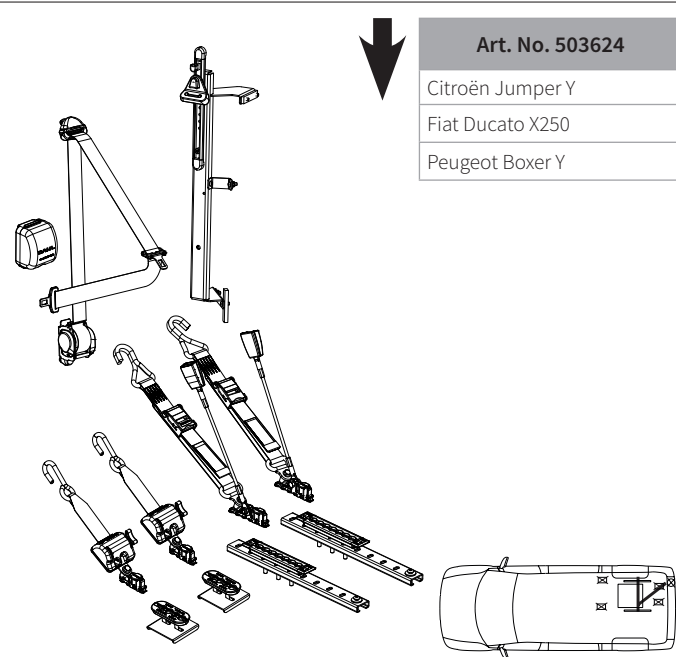

Art. No. 503624
Citroën Jumper Y
Fiat Ducato X250
Peugeot Boxer Y

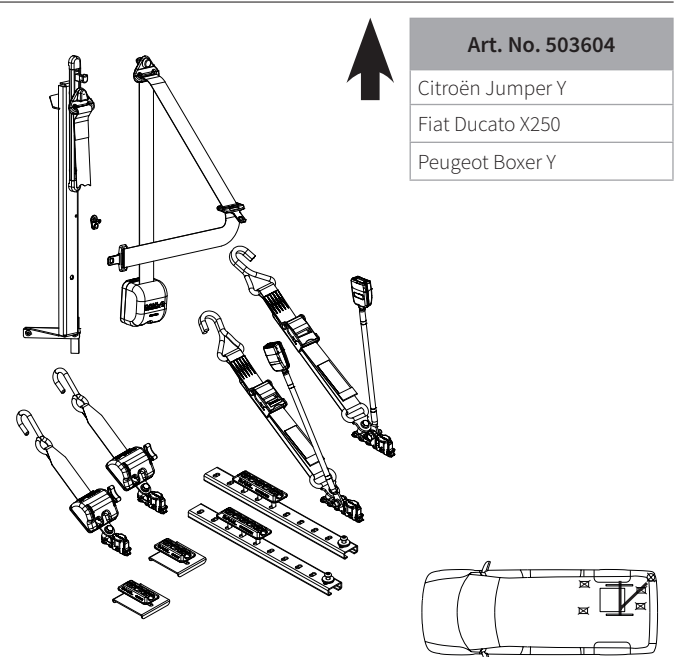

Art. No. 503604
Citroën Jumper Y
Fiat Ducato X250
Peugeot Boxer Y

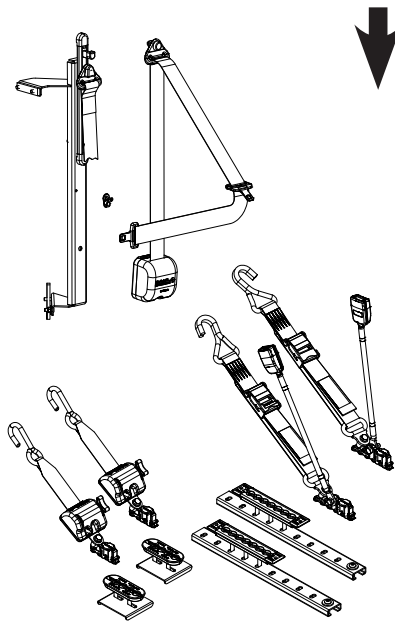

↓

Art. No. 503605
Citroën Jumper Y
Fiat Ducato X250
Peugeot Boxer Y

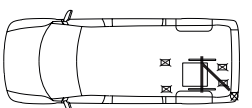
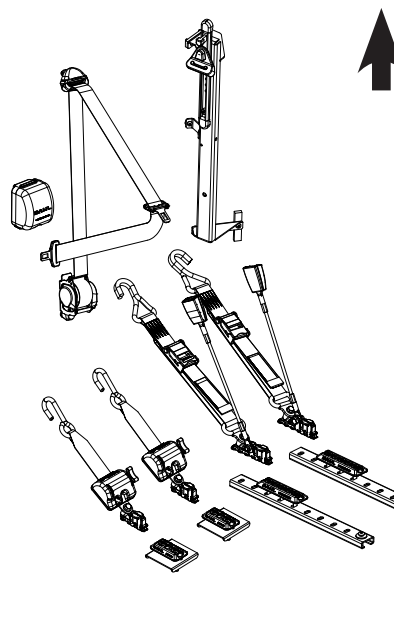
↑

Art. No. 503625
Citroën Jumper Y
Fiat Ducato X250
Peugeot Boxer Y

↑

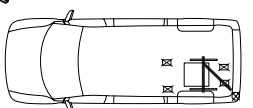
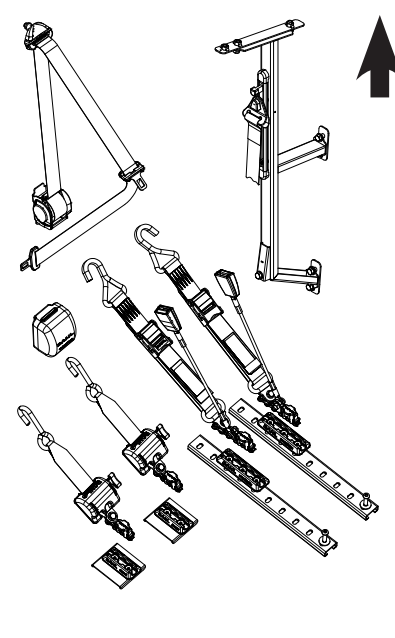
Art. No. 500118
MAN TGE 2017-
Mercedes Sprinter 907&910
VW Crafter 2006-2016
VW Crafter 2017-
HIGH ROOF ONLY

↓

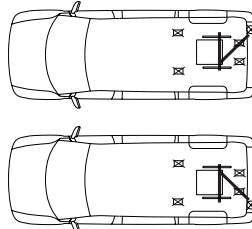
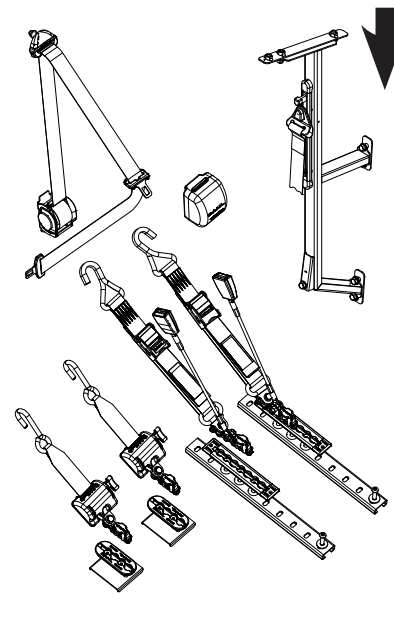
Art. No. 500119
MAN TGE 2017-
Mercedes Sprinter 907&910
VW Crafter 2006-2016
VW Crafter 2017-
HIGH ROOF ONLY

↑

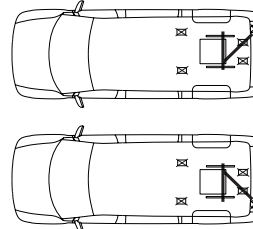
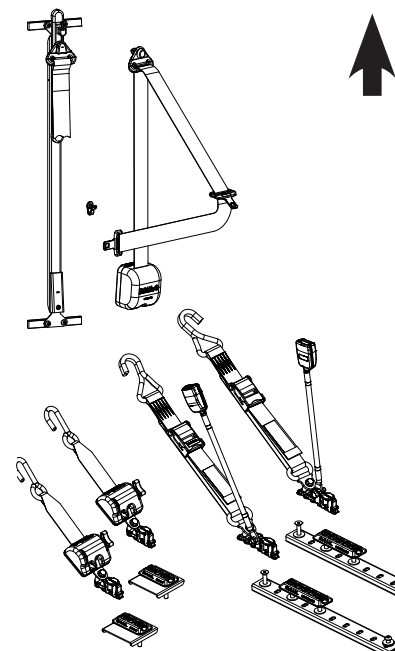
Art. No. 500826
MB Sprinter 906, 907 & 910
VW Crafter 2006-2016





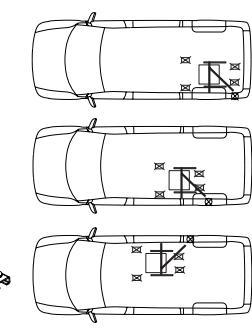
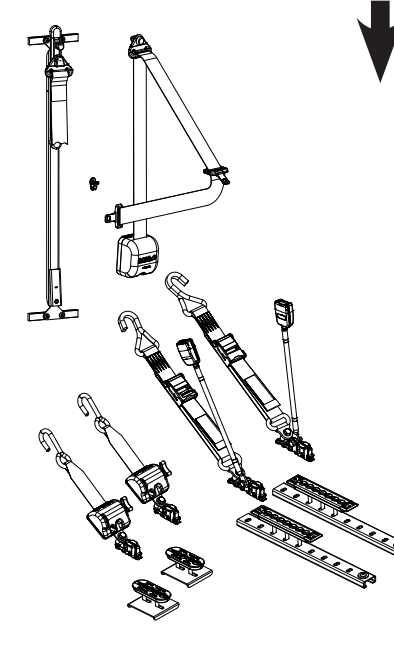

↓

Art. No. 500827
MB Sprinter 906, 907 & 910
VW Crafter 2006-2016

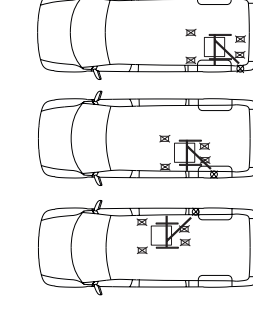

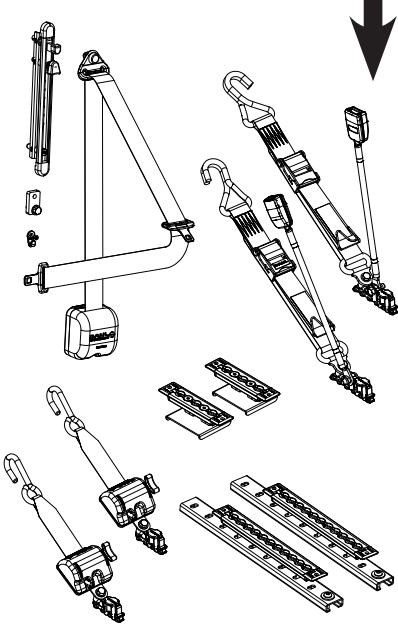



Art. No. 504249
Renault Master XDD
Nissan Interstar 2024-

FMVSS/CMVSS 210

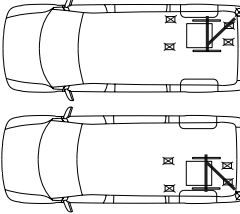
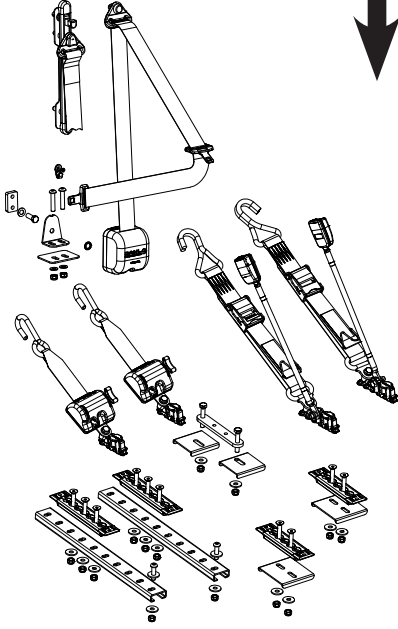
Art. No. 504279
Ford Transit Custom V710
VW New Transporter /
Caravelle 2025-

FMVSS/CMVSS 210

Art. No. 504280
Ford Transit Custom V710
VW New Transporter /
Caravelle 2025-

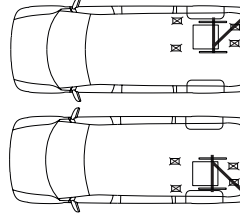
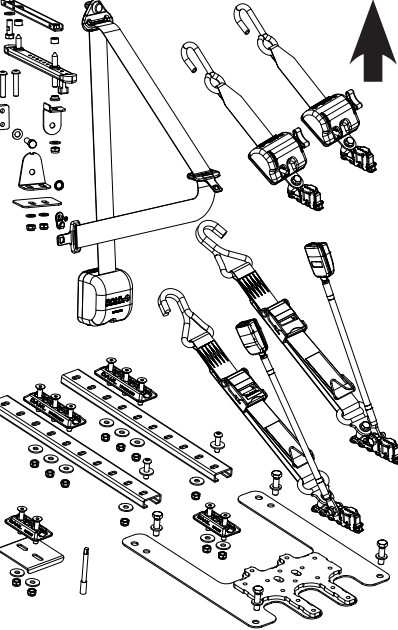
FMVSS/CMVSS 210

Art. No. 504281
Ford Transit Custom V710
VW New Transporter /
Caravelle 2025-

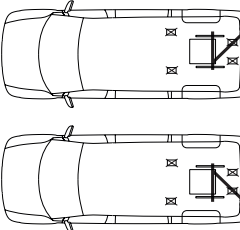
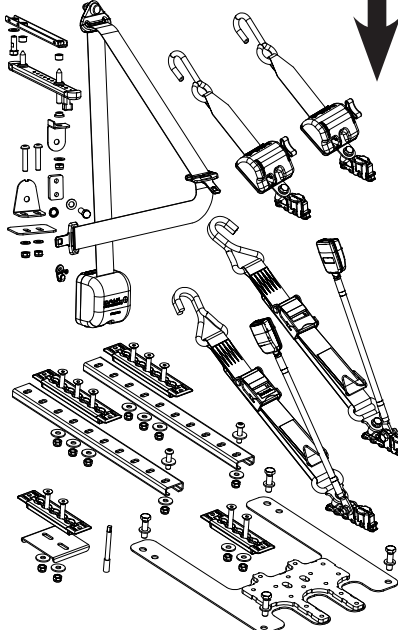
FMVSS/CMVSS 210

Art. No. 504282
Ford Transit Custom V710
VW New Transporter /
Caravelle 2025-

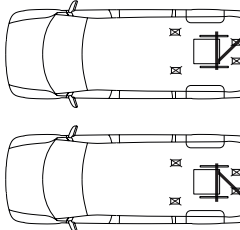
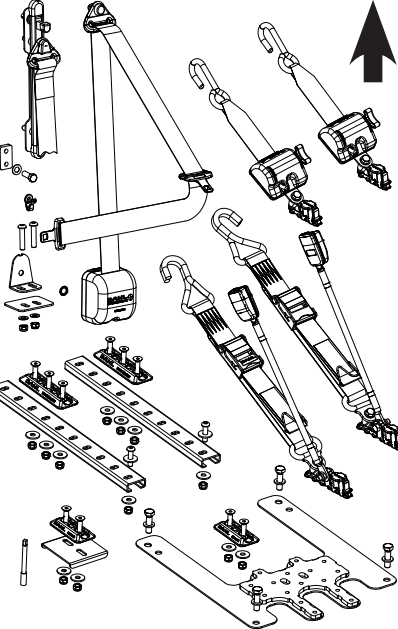
FMVSS/CMVSS 210

Art. No. 504283
Ford Transit Custom V710
VW New Transporter /
Caravelle 2025-

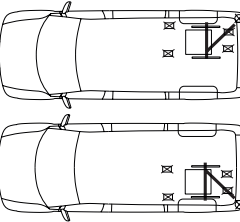
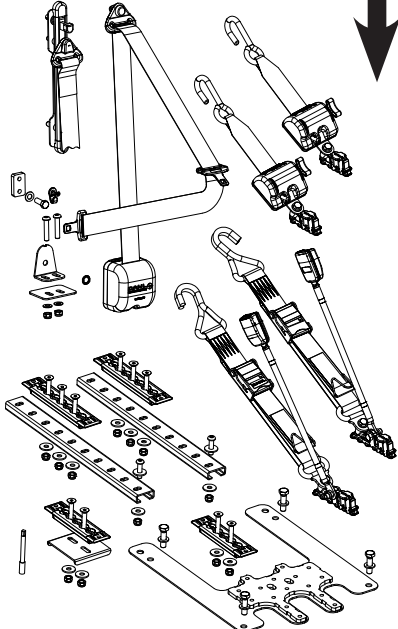
FMVSS/CMVSS 210



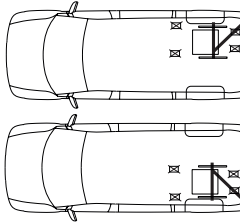

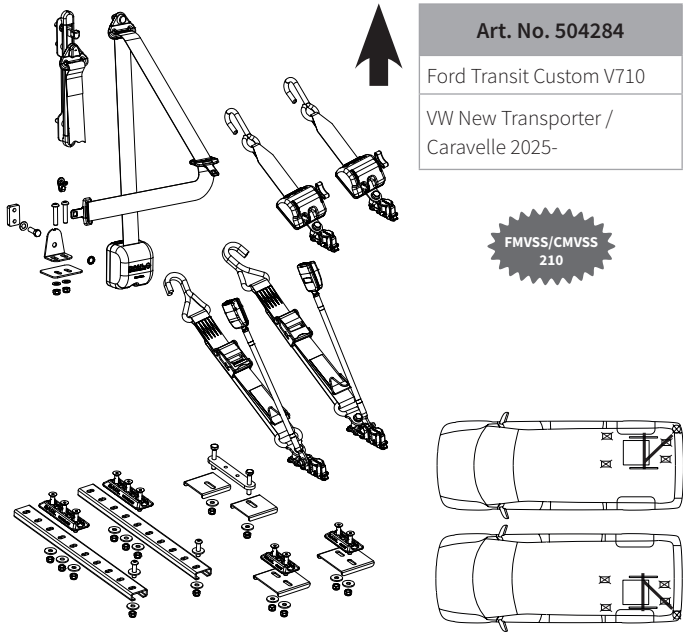
Le Siège COMFORT™



Le «siège Comfort» est le seul siège sur le marché pour les minibus avec une ceinture 3 points conçu avec un soutien latéral supplémentaire et des ressorts sous le rembourrage de l'assise et du dossier.

Le «siège Comfort» a donc le même niveau de confort que les sièges d'automobiles. Habituellement, l'assise et le dossier des minibus sont montés sur des plaques de métal ou de contreplaqué.

Le siège COMFORT est également disponible avec les accoudoirs réglables et des glissières.

Des exemples de configuration approuvée, basée sur notre Siège COMFORT et VarioDock, sont illustrés ici

Le système VarioDock™ Dahl fournit plus de souplesse et de versatilité que tout autre système d'arrimage sur le marché, vu que c'est le seul système approuvé pour l'ancrage de sièges et de fauteuils roulants. Dans les véhicules équipés du système VarioDock™, la disposition et la configuration des sièges peuvent être modifiées plus rapidement, nécessitant moins de temps et de travail qu'avec tout autre système d'attache.

Nous avons choisi de montrer un exemple par modèle de véhicule, mais les options sont innombrables. Veuillez nous contacter pour trouver la configuration dont vous avez besoin.

ATTENTION

Assurez-vous de la catégorie du véhicule (M1, M2, M3), de l'empattement, des divers équipements, d'origine ou supplémentaires, tel que haillon élévateur, ce qui est déterminant pour savoir si un véhicule convient pour une configuration particulière, car ceci affecte la charge utile, les exigences de distance entre les sièges et les fauteuils roulants, la largeur du passage, l'accès aux sorties de secours, et autres, dans le véhicule.

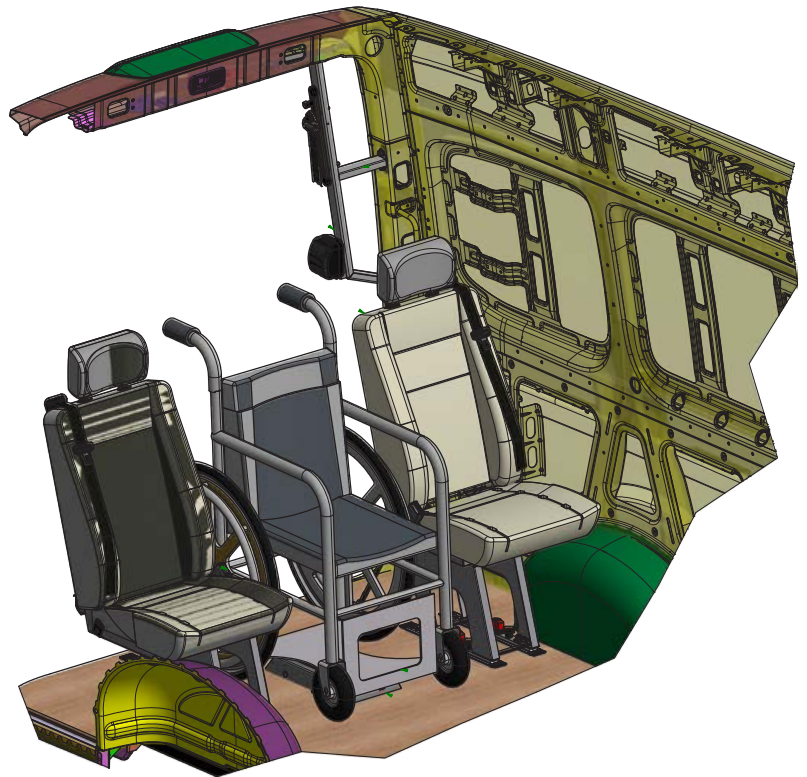

Le fauteuil roulant peut être remplacé par le siège COMFORT Dahl.

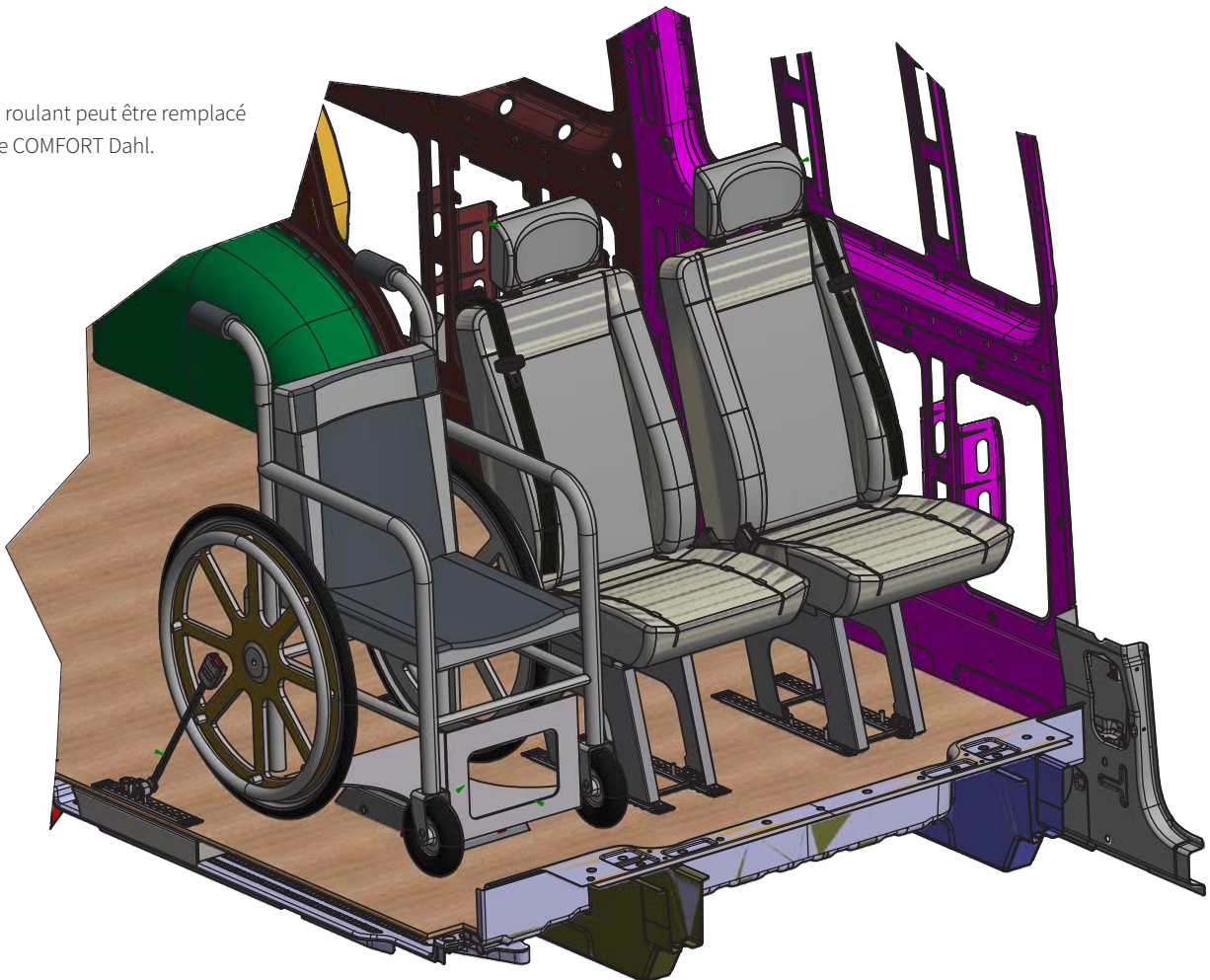

Système Dahl VarioDock - exemples d'installation pour l'ancrage des sièges

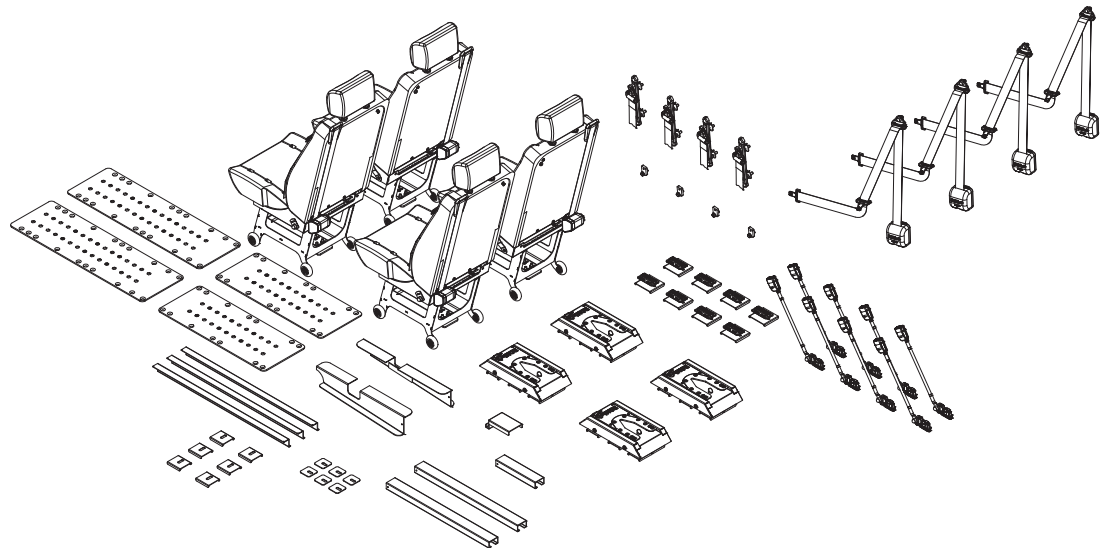

Art. No. 503661
VW T5 & T6

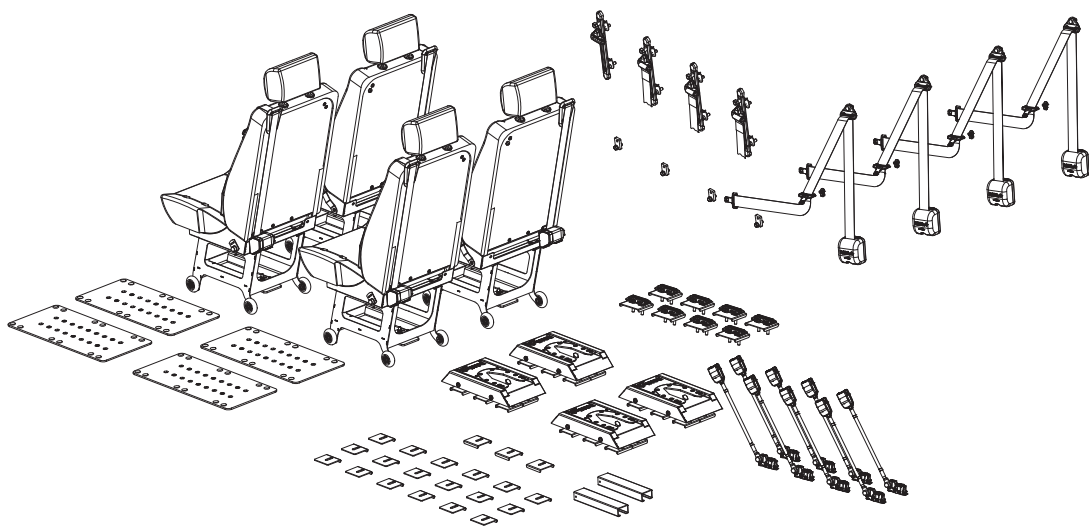

Art. No. 503662
Mercedes Vito &
V-Class W447

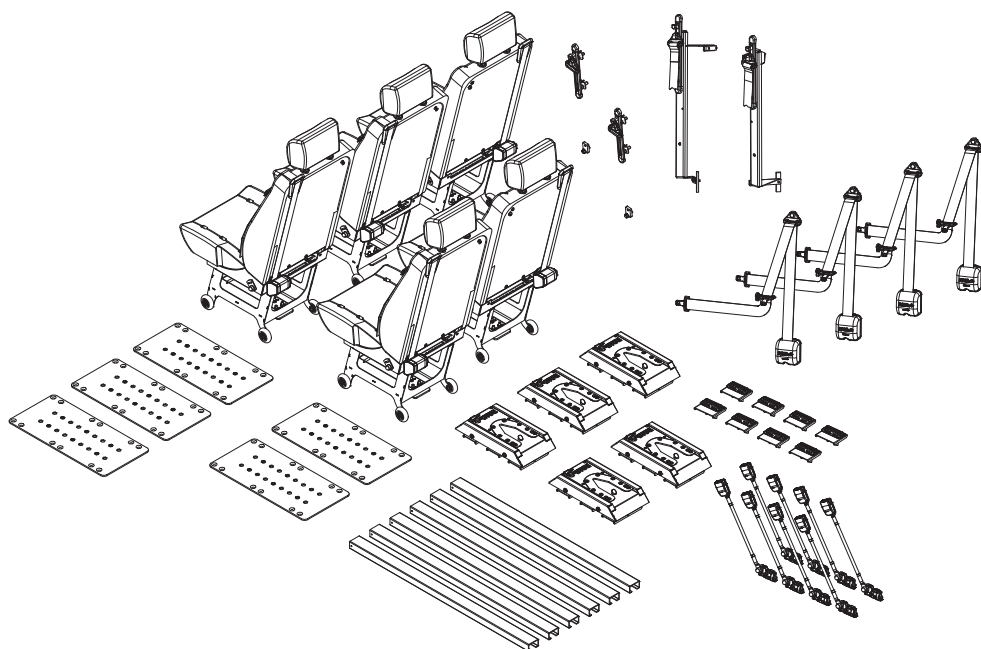

Art. No. 503663
Citroën Jumper Y
Fiat Ducato X250
Peugeot Boxer Y

Système Dahl VarioDock - exemples d'installation pour l'ancrage des sièges

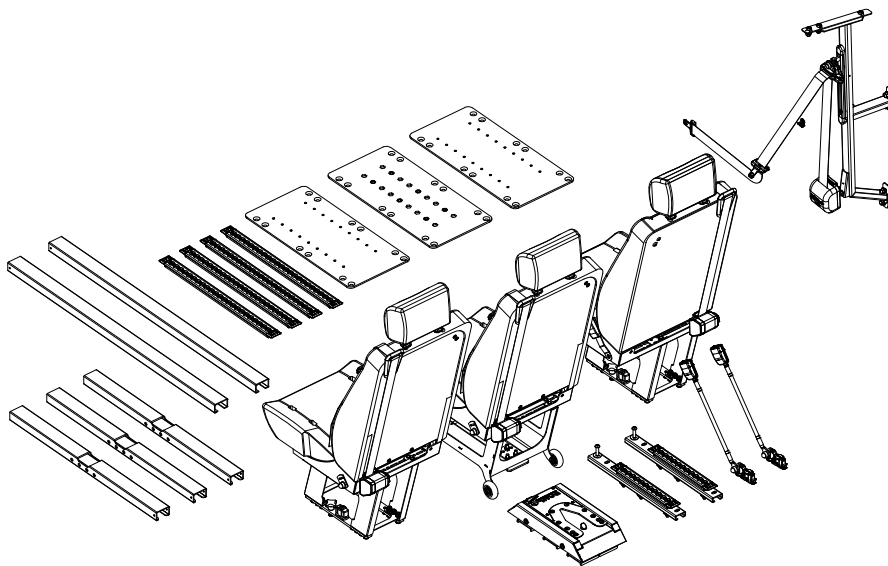

Art. No. 503776

MB Sprinter 906, 907 & 910

VW Crafter -2017

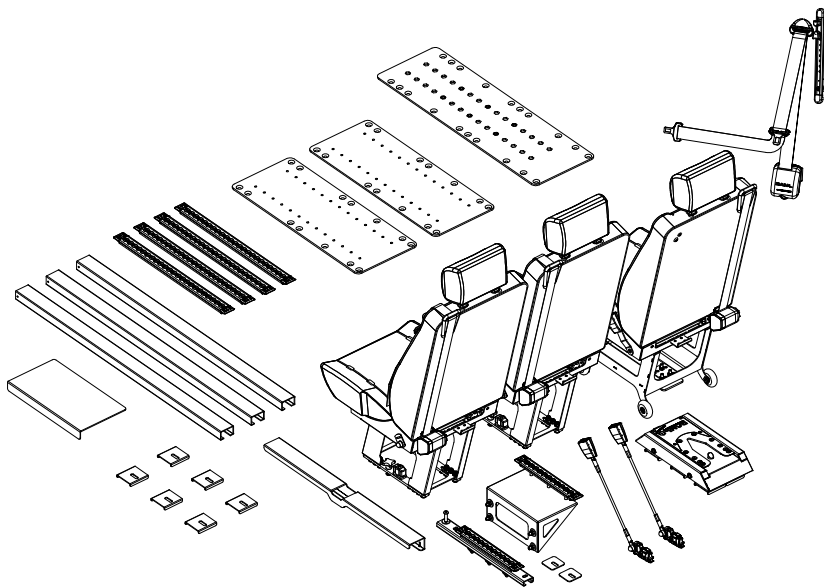
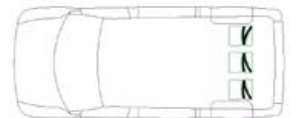

Art. No. 503779

MB Sprinter 906, 907 & 910

VW Crafter -2017

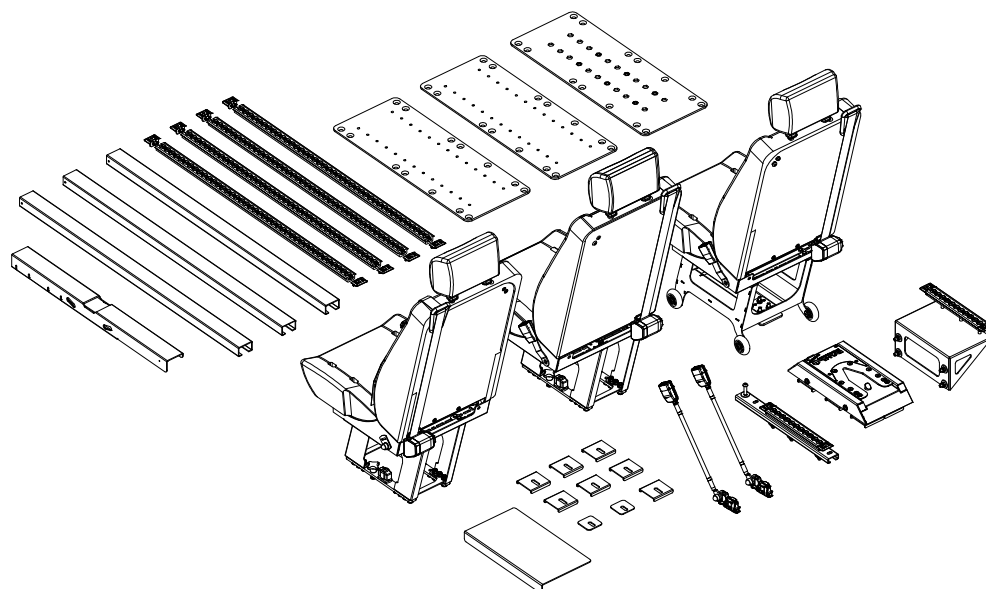
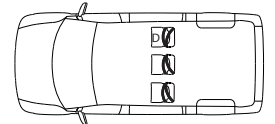
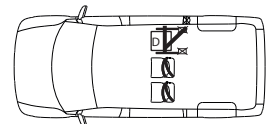

Art. No. 501155

MB Sprinter 906, 907 & 910

VW Crafter -2017

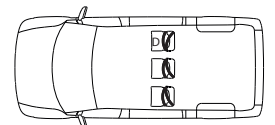
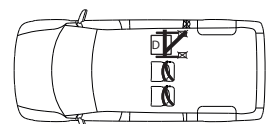

Système Dahl VarioDock - exemples d'installation pour l'ancrage des sièges

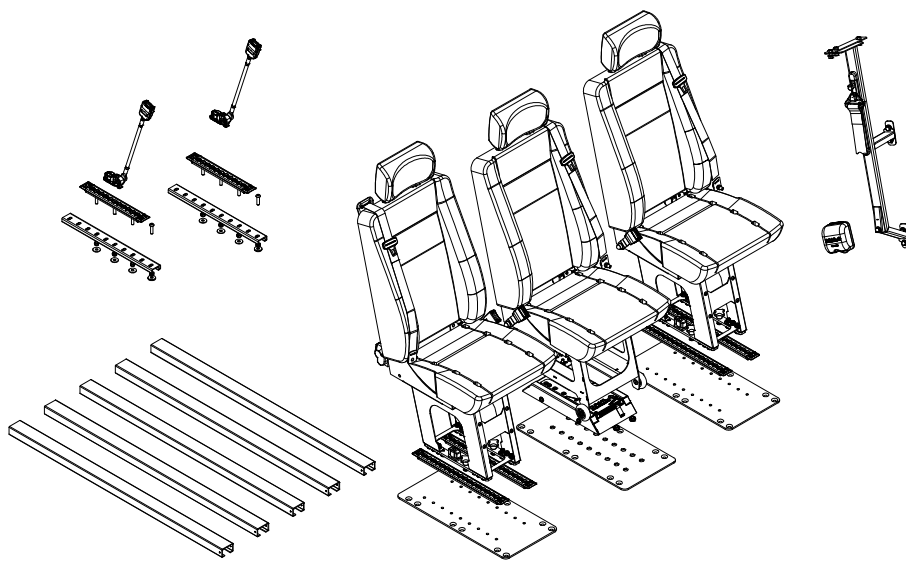

Art. No. 501451

MAN TGE 2017-

VW Crafter -2017

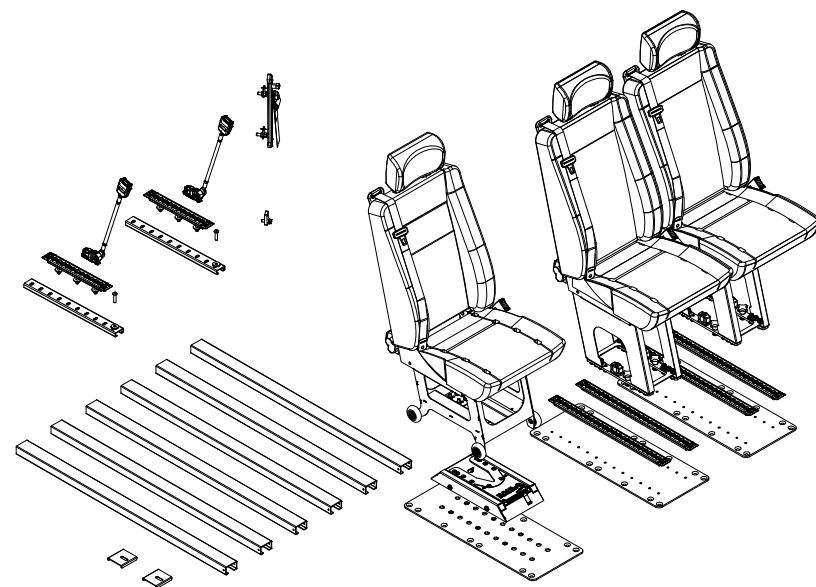
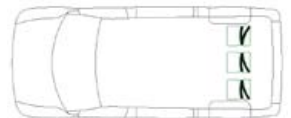

Art. No. 501457

Nissan NV400

Opel Movano X62

Renault Master X62

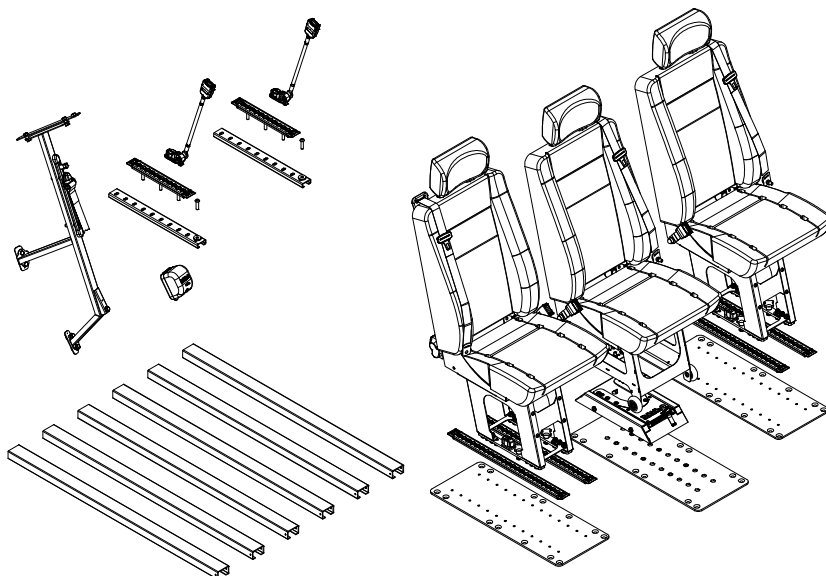
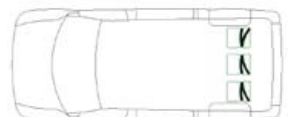

Art. No. 501458

Nissan NV400

Opel Movano X62

Renault Master X62

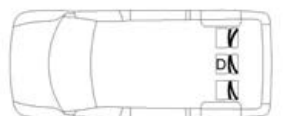
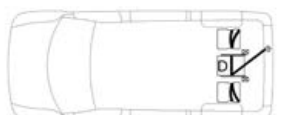

Kit d'installation de siège Dahl

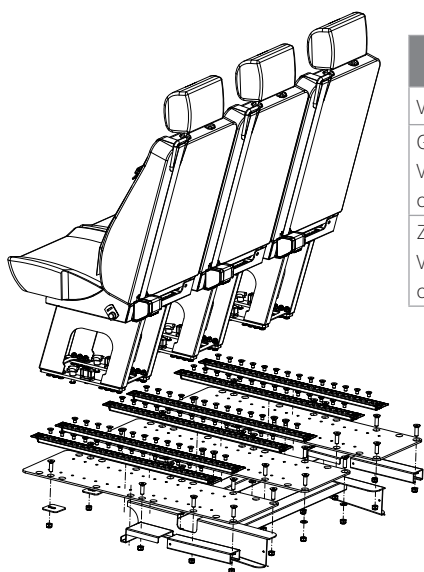

Art. No. 503380
VW T5 & T6 original floor
GM Coachwork Colorado
VW T5 & T6 drop floor conversion
Zawatzky centervan
VW T5 & T6 drop floor conversion

DAHL COMFORT SEAT

Art. No. 503382
VW T5 & T6 original floor
GM Coachwork Colorado
VW T5 & T6 drop floor conversion
Zawatzky centervan
VW T5 & T6 drop floor conversion

DAHL COMFORT SEAT

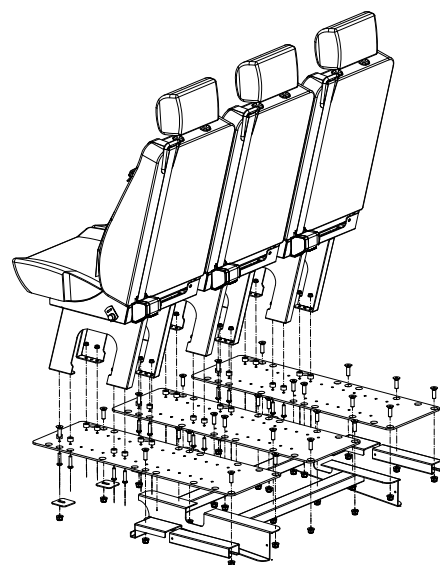
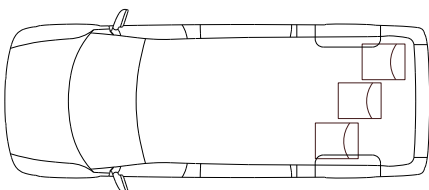

Art. No. 503381
VW T5 & T6 original floor
GM Coachwork Colorado
VW T5 & T6 drop floor conversion
Zawatzky centervan
VW T5 & T6 drop floor conversion

DAHL COMFORT SEAT

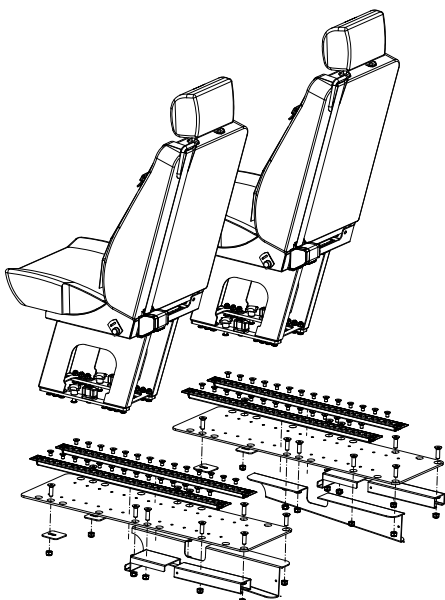
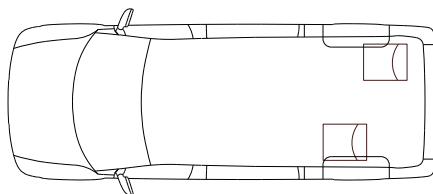

Art. No. 503960
MB Vito V-Class 639-2
MB Vito W447

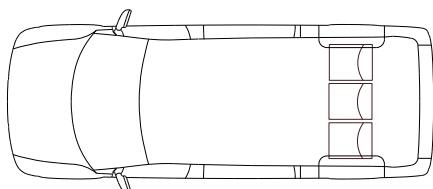

CONDITIONS DE VENTE ET DE LIVRAISON de Dahl Engineering ApS & Maskinfabrik Dahl Engineering ApS 01.11.2024

1.0 Base contractuelle

1.1 Tout contrat et toute livraison se feront conformément aux conditions générales de vente et de livraison.

2.0 Offre et conclusion du contrat

- 2.1 Le délai d'acceptation d'une offre faite par Dahl est de 15 jours civils.
- 2.2 Un contrat définitif de vente ou d'autres prestations n'est pas conclu avant que Dahl ait confirmé la commande par écrit.
- 2.3 Un contrat est considéré comme conclu aux conditions indiquées dans la confirmation de commande si l'acheteur n'a pas fait de réclamation écrite à ce sujet au plus tard 5 jours suivant la réception.
- 2.4 Les matériels de vente, descriptions, instructions, listes de prix, etc. sont donnés à titre indicatif seulement et n'ont aucun caractère contraignant.

3.0 Prix

- 3.1 Si les prix indiqués sont basés sur une devise étrangère, ils seront modifiés en fonction (i) des fluctuations des taux de change, (ii) de l'augmentation des prix des fournisseurs et (iii) des modifications des tarifs de transport durant la période comprise entre la soumission de l'offre et l'envoi de la facture.
- 3.2 Des frais de traitement de commande d'une valeur de 17 € seront appliqués pour toute commande d'une valeur nette hors transport inférieure à 107 €.

4.0 Livraison et retard

- 4.1 La livraison s'effectue départ usine Dahl - Thisted et l'envoi s'effectue aux frais et aux risques de l'acheteur.
- 4.2 La date de livraison est précisée dans la confirmation de commande de Dahl.
- 4.3 En cas de retard, la responsabilité civile de Dahl se limite aux pertes directes avérées subies par l'acheteur et exclut les pertes de bénéfices et autres pertes indirectes. D'autre part, elle est limitée à 25 % du montant d'achat pour la livraison retardée.

5.0 Paiement

- 5.1 Le premier paiement d'un nouvel acheteur sera anticipé. Si l'acheteur peut faire l'objet d'une assurance crédit aux conditions normales, le paiement doit être effectué au plus tard 20 jours après la date de facturation. En cas de non-paiement à la date d'échéance, un intérêt de 1,5 % par mois commencé est dû.
- 5.2 Les factures, relevés de compte, etc. seront uniquement envoyés au format numérique à l'adresse e-mail indiquée par l'acheteur sur le formulaire d'ouverture de compte Dahl Engineering pour les nouveaux comptes client.

6.0 Réserve de propriété

6.1 Dahl conserve les droits de propriété sur le produit vendu jusqu'au paiement de la totalité du montant de l'achat.

7.0 Réclamation et défauts

- 7.1 Dès que la marchandise est arrivée sur le site de l'acheteur, celui-ci doit effectuer les inspections nécessaires de la marchandise.
- 7.2 Si l'acheteur entend invoquer des anomalies dans la livraison, il les notifiera à Dahl par écrit dès que l'anomalie a été ou aurait dû être constatée par l'acheteur, ladite notification devant mentionner spécifiquement la nature des anomalies en question. En cas de non réclamation par l'acheteur comme indiqué, il ne pourra pas faire valoir les anomalies ultérieurement.
- 7.3 En tout état de cause, la réclamation doit être présentée par écrit à Dahl au plus tard 6 mois après la livraison de la marchandise. L'acheteur ne peut donc pas faire valoir des anomalies lors d'une réclamation ultérieure.

8.0 Limitation de responsabilité

- 8.1 Si les produits livrés par Dahl présentent des défauts ou des anomalies qui engagent sa responsabilité, la responsabilité de Dahl est limitée à une action corrective, dans la mesure où il peut être remédié à ces anomalies, et au remplacement ou au paiement d'un dédommagement à hauteur du montant de la facture, au gré de Dahl.
- 8.2 Dahl n'a donc pas l'obligation de dédommager davantage que ce qui est indiqué ci-dessus de quelconques pertes directes ou indirectes supplémentaires, y compris des pertes d'exploitation et de bénéfices.
- 8.3 Dahl Engineering ApS décline toute responsabilité en cas de non-respect des notices d'installation tout comme les manuels et les instructions fournies, ou si les produits sont installés dans des véhicules dont le montage n'a pas été approuvé par Dahl au moment de l'installation.

9.0 Responsabilité du fait des produits

- 9.1 La responsabilité civile de Dahl pour des dommages corporels ne peut en aucun cas dépasser le niveau de dédommagement prévu à tout moment par le droit danois.
- 9.2 En cas de dommage matériel, la responsabilité de Dahl du fait des produits est plafonnée à un montant de 1 000 000 DKK par sinistre. Un sinistre est défini comme tout dommage causé par le même défaut ou la même négligence. Le plafond de montant ne s'applique cependant pas en cas de négligence grave de la part de Dahl.
- 9.3 Dahl n'est pas responsable de pertes d'exploitation ou de bénéfices ou d'autres pertes indirectes.
- 9.4 Dahl décline toute responsabilité du fait des produits en cas de non-respect des instructions de montage et autres consignes et directives, ou si les produits sont installés dans des véhicules dont le montage n'a pas été approuvé par Dahl au moment de l'installation.
- 9.5 Dans la mesure où la responsabilité du fait des produits de Dahl est engagée vis-à-vis d'un tiers, l'acheteur s'engage à indemniser Dahl selon les conditions ci-dessus concernant les limites de la responsabilité de Dahl.
- 9.6 Si un tiers intente une action contre Dahl ou l'acheteur concernant la responsabilité du fait des produits, les parties sont mutuellement tenues de s'en informer, de même qu'elles sont l'une et l'autre tenues de comparaître devant le tribunal où une action a été intentée contre l'une d'elles parce que la responsabilité du fait des produits serait prétendument engagée pour les produits vendus par Dahl, de même que les relations entre les parties peuvent être résolues devant le tribunal mentionné.

10.0 Droits immatériels

- 10.1 Dahl décline toute responsabilité à l'égard de l'acheteur en cas de violation de droits d'un tiers. En cas de violation, Dahl a le droit de (i) modifier, de remplacer les marchandises sans déprécier leur objectif et leur performance, (ii) de racheter les marchandises au prix de facturation, avec déduction pour dépréciation, ou (iii) de donner à l'acheteur le droit de continuer à les utiliser. L'acheteur informera Dahl de toute exigence de cette nature et, dans la mesure où une exigence a des conséquences pour Dahl, Dahl a le droit d'intenter une action pour son compte et celui de l'acheteur.

11.0 Marchandises en retour

- 11.1 Les marchandises livrées ne pourront être retournées qu'à titre exceptionnel et uniquement après en avoir convenu. Les marchandises qui seraient spécialement produites pour l'acheteur ou achetées par l'acheteur ne peuvent en aucun cas être retournées.
- 11.2 Les marchandises retournées après acceptation de Dahl seront créditées après déduction de 20 % du prix de vente hors TVA livrées franco de port, dans un état intact, à l'entrepôt de Dahl ou dans un autre lieu indiqué par Dahl.

12.0 Force majeure

- 12.1 Dahl n'est en aucun cas responsable d'une exécution insuffisante du contrat sur le plan contractuel qui engage normalement sa responsabilité, si ceci est dû à un conflit de travail, un incendie, une guerre, un appel militaire, une saisie, des restrictions de change, une pénurie de moyens de transport ou d'autres circonstances similaires que Dahl ne pouvait raisonnablement prévoir à la date de conclusion du contrat, notamment lorsque les circonstances mentionnées ou similaires frappent les sous-traitants utilisés par Dahl.

13.0 Juridiction compétente et droit applicable

- 13.1 Tout litige entre Dahl et l'acheteur sera soumis au tribunal de Holstebro, ou Vestre Landsret, et au droit danois.
- 13.2 Dahl a cependant le droit de décider que les litiges seront plutôt résolus par arbitrage devant l'Institut danois d'arbitrage (Voldgiftsinstituttet) conformément aux règles en vigueur lors de l'ouverture de la procédure d'arbitrage.

WHERE SAFETY STARTS

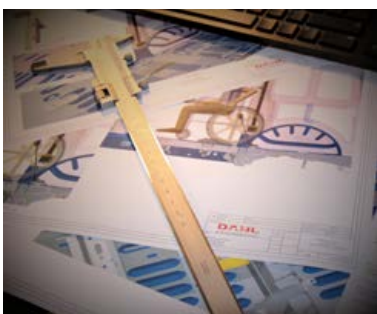
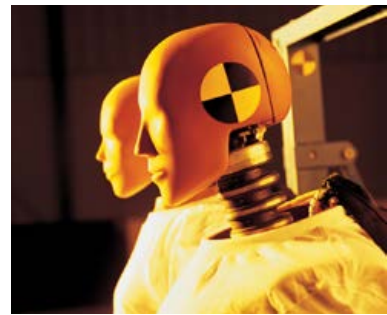

Development and crash-test centre
Where safety starts

Dahl Engineering ApS | Løvevej 3 | DK-7700 Thisted | Danmark | Téléphone: +45 9618 0077 | Fax: +45 9618 0078
e: sales@dahlengineering.dk | w: wtors.com